



# Quantum DXi Veeam Installation Guide

---

This document contains the following topics:

|                                      |    |
|--------------------------------------|----|
| Overview .....                       | 1  |
| Preparing for the Installation ..... | 3  |
| DXi System Configuration .....       | 5  |
| Veeam Configuration .....            | 34 |
| Manage Veeam .....                   | 48 |

---

## Overview

This document provides instructions for installing and configuring Veeam™ Linux Repository on DXi4700, DXi6900, and DXi6900-S systems.

---

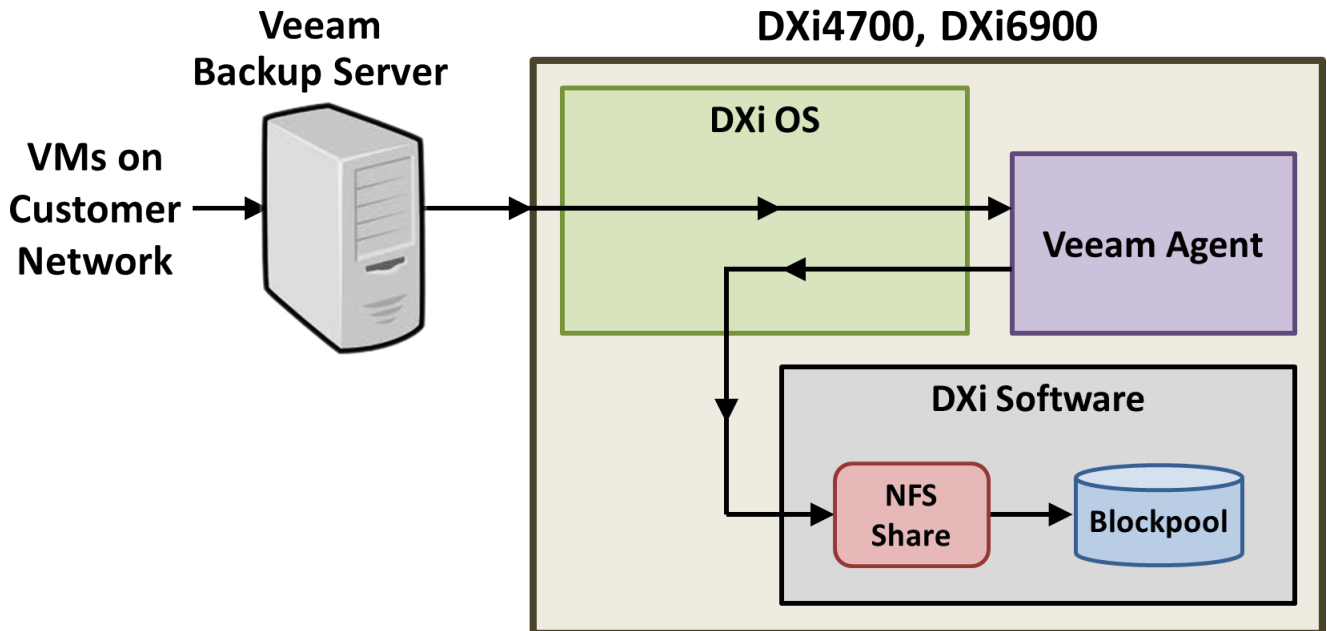
© 2018 Quantum Corporation. All rights reserved. Your right to copy this manual is limited by copyright law. Making copies or adaptations without prior written authorization of Quantum Corporation is prohibited by law and constitutes a punishable violation of the law. Artico, Be Certain (and the Q brackets design), DLT, DXi, DXi Accent, DXi V1000, DXi V2000, DXi V4000, DXiV-Series, FlexSpace, FlexSync, FlexTier, Lattus, the Q logo, the Q Quantum logo, Q-Cloud, Quantum (and the Q brackets design), the Quantum logo, Quantum Be Certain (and the Q brackets design), Quantum Vision, Scalar, StorageCare, StorNext, SuperLoader, Symform, the Symform logo (and design), vmPRO, and Xcellis are either registered trademarks or trademarks of Quantum Corporation and its affiliates in the United States and/or other countries. All other trademarks are the property of their respective owners. Products mentioned herein are for identification purposes only and may be registered trademarks or trademarks of their respective companies. All other brand names or trademarks are the property of their respective owners. Quantum specifications are subject to change.

**Veeam**

The Veeam feature on the DXi allows the system to perform backup and replication with Veeam software on VMware vSphere and Microsoft Hyper-V virtual environments.

The Veeam Agent runs in the DXi process space with direct access to DXi resources, providing better performance than Veeam running against a DXi NAS share as a shared folder.

The simplified block diagram below shows the data flow in a typical Veeam installation. Management communication is omitted for simplicity. The VMs on the Customer Network are identified by the Veeam Backup Server. The backups can be full or incremental using the Veeam Agent changed block tracking. At the scheduled backup, the Veeam Agent works with the Veeam Backup Server to facilitate the data movement from the backup sources to the DXi. The backup data is sent by the Veeam Agent to the NFS Share for deduplication and storage in the Blockpool.



---

# Preparing for the Installation

Before you begin the Veeam installation, make the following preparations:

- [Review Veeam System Requirements below](#)
- [Checking System Health below](#)
- [Accessing Remote Management on the next page](#)

## Review Veeam System Requirements

The following items are required to successfully install and configure Veeam on a DXi system.

| Requirement           | Description  |
|-----------------------|--|
| <b>Veeam License</b>  | A Veeam License must installed on the DXi system.  |
| <b>DXi Software</b>   | The DXi system must be running DXi 3.4.0 Software or higher.   |
| <b>GUI Admin User</b> | You must have the GUI Administrator user account password.   |
| <b>Memory</b>         | Depending on the current DXi system memory, a memory upgrade may be required.  |
| <b>NAS Support</b>    | The DXi must have NAS support. The following systems support NAS: <ul style="list-style-type: none"><li>• DXi4700 - NAS Configuration</li><li>• DXi4700 - Multi-Protocol Configuration</li><li>• DXi6900</li><li>• DXi6900-S</li></ul> |

## Checking System Health

Make sure the following conditions are met before you continue with Veeam installation:

- All backup jobs are completed and there is no pending I/O.
- All replication jobs are completed, and replication is paused (**Replication > Actions** page).
- All space reclamation tasks are completed without errors (**Utilities > Space Reclamation** page).
- All healthchecks are completed without errors (**Utilities > Space Reclamation** page).
- All components in the system display Normal status (**Status > Hardware** page).

- All outstanding administration alerts are deleted (**Alerts > Admin Alerts** page).
- All service tickets are closed (**Alerts > Service Tickets** page).

For more information, click **Help** in the remote management console to display the DXi online help. To access remote management, see [Accessing Remote Management below](#)).

## Accessing Remote Management

To access the remote management console, do the following:

1. Launch a supported Web browser on a workstation that has network access to the DXi

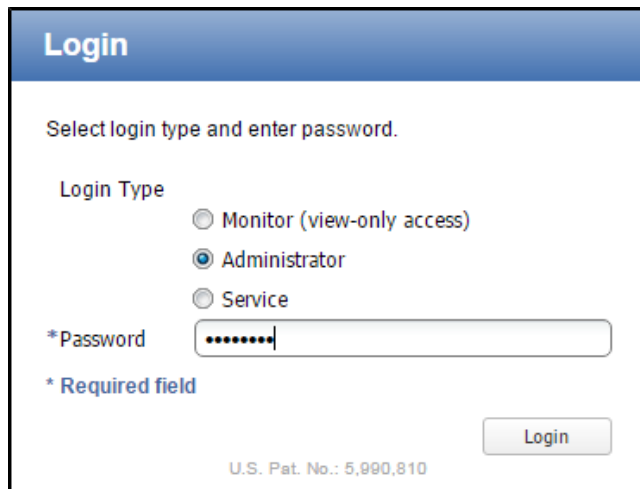
The DXi remote management console supports the following Web browsers:

- Mozilla Firefox 36 or later
- Google Chrome 40 or later
- Microsoft Internet Explorer 11.

2. In the browser address box, type the IP address of the DXi, and then press **<Enter>**.

The **Login** window displays (see [Figure 1 below](#)).

**Figure 1:** Login Window



If the **Login** window does not display, verify that the IP address is correct and that the network path to the DXi system is valid. Also verify that you are using a supported Web browser. Then try again. If you are still unable to access the **Login** window, contact the DXi GUI administrator.

3. Select **Administrator** and enter the **GUI Administrator** user password.
4. Click **Login**.

- If a security banner message has been specified for the DXi, click **Accept**.  
The **Home** page displays.

---

## DXi System Configuration

To perform the Veeam configuration on the DXi system, complete the following steps in order:

| Step | Description  | Procedure to Complete  |
|------|--|--|
| 1    | The DXi requires DXi 3.4 Software and above to complete the Veeam installation. Review the current software version and perform an upgrade if necessary. | Go to <a href="#">Software Upgrades below</a> .              |
| 2    | Review the Veeam memory requirements and install additional DXi memory if necessary.   | Go to <a href="#">Install Additional Memory on page 13</a> . |
| 3    | Install the Veeam License on the DXi.  | Go to <a href="#">Install the Veeam License on page 29</a> . |
| 4    | Create a NAS share on the DXi.   | Go to <a href="#">Create a NAS Share on page 30</a> .        |
| 5    | Enable the Veeam feature on the DXi.   | Go to <a href="#">Enable Veeam on the DXi on page 31</a> .   |

## Software Upgrades

The DXi system requires DXi 3.4.0 Software and above to successfully complete a Veeam installation. If the system is already running DXi 3.4.0 Software and above, go to [Install Additional Memory on page 13](#).


There are two methods for upgrading the DXi software:

---

**Check for an upgrade (Home page)**

The DXi can automatically check for software upgrades on the **Home** page, or you can manually perform an upgrade check. If an upgrade is found, you can choose to download and install it.

This is the recommended method for upgrading, but it requires that the DXi be able to access the Internet.


 **Caution:** Configure your firewall so that the DXi can send data to and received data from updates.quantum.com using port 80 (HTTP).

---

**Upload a software upgrade file (Software Upgrade page)**

You can download a software upgrade file from the Quantum Service and Support Web site and then manually upload it to the DXi using the **Software Upgrade** page.


You can use this method if the DXi cannot access the Internet.

 **Note:** Uploading a software upgrade file may be useful if you are upgrading multiple DXi systems, as the file only needs to be downloaded once. Also, this method assures that all systems will be running the same software version following the upgrade.

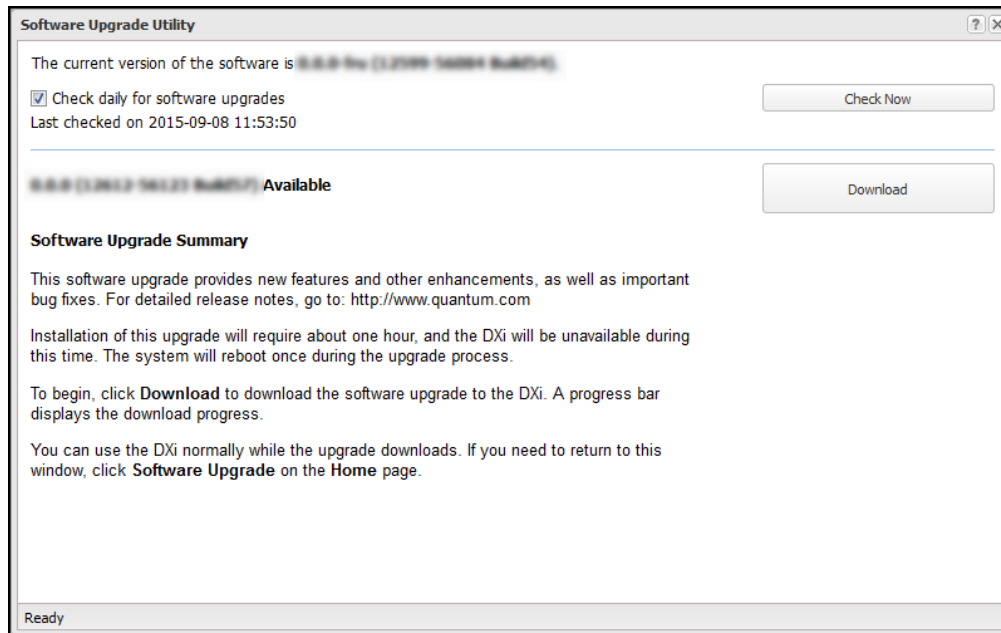
---

## Checking For Software Upgrades

The **Software Upgrade Utility** (accessible from the **Home** page) allows you to check for available DXi software upgrades and, if available, download and install them. You can also configure the Veeam to automatically check for software upgrades.

 **Note:** To check for and download software upgrades, the DXi must be able to access the Internet. If the DXi cannot access the Internet, see [Uploading a Software Upgrade File on page 10](#).

To access the **Software Upgrade Utility**, click **Home** on the main menu, and then click the **Software Upgrade** link (see [Figure 2 on the next page](#)).

**Figure 2:** Software Upgrade Utility

## Tasks

Use the **Software Upgrade Utility** to perform the following tasks:

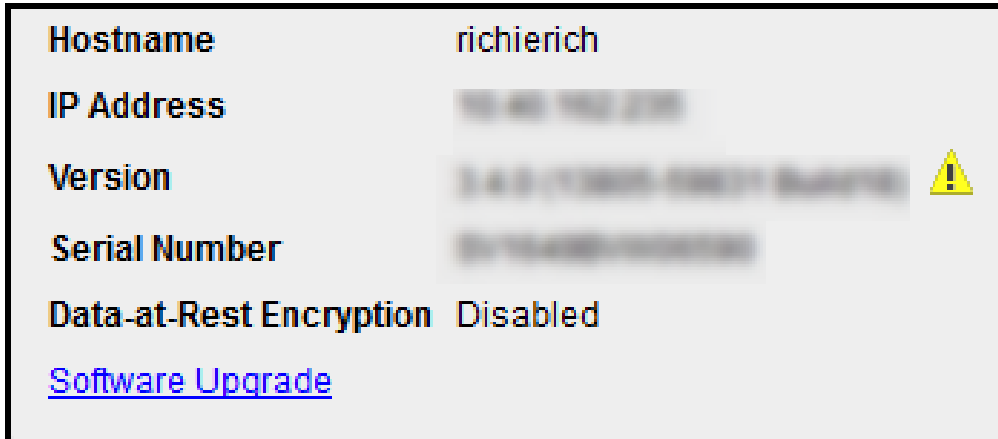
- Configure the Veeam to automatically check for software upgrades (see [Automatically Checking for Upgrades below](#)).
- Manually check for software upgrades (see [Manually Checking for Upgrades on the next page](#)).
- Download and install available software upgrades (see [Downloading and Installing Upgrades on the next page](#)).

## Automatically Checking for Upgrades

The Veeam can automatically check for available software upgrades on a daily basis. If a software upgrade is found, you will be notified by an admin alert as well as by a Quick Tip icon on the **Home** page, next to the current software version (see [Figure 3 on the next page](#)).

On the **Software Upgrade Utility**, select the **Check daily for software upgrades** check box to enable automatic upgrade checking. Automatic upgrade checking is enabled by default. To disable automatic upgrade checking, clear the **Check daily for software upgrades** check box (not recommended).

Figure 3: Home Page - Software Upgrade Available



### Manually Checking for Upgrades

To check for available software upgrades at any time, on the **Software Upgrade Utility**, click **Check Now**.

If a software upgrade is available, you can read information about the contents of the upgrade and, if you choose, download and install it.

### Downloading and Installing Upgrades

If a software upgrade is available (after automatically or manually checking for upgrades), a summary describing the upgrade displays on the **Software Upgrade Utility**.

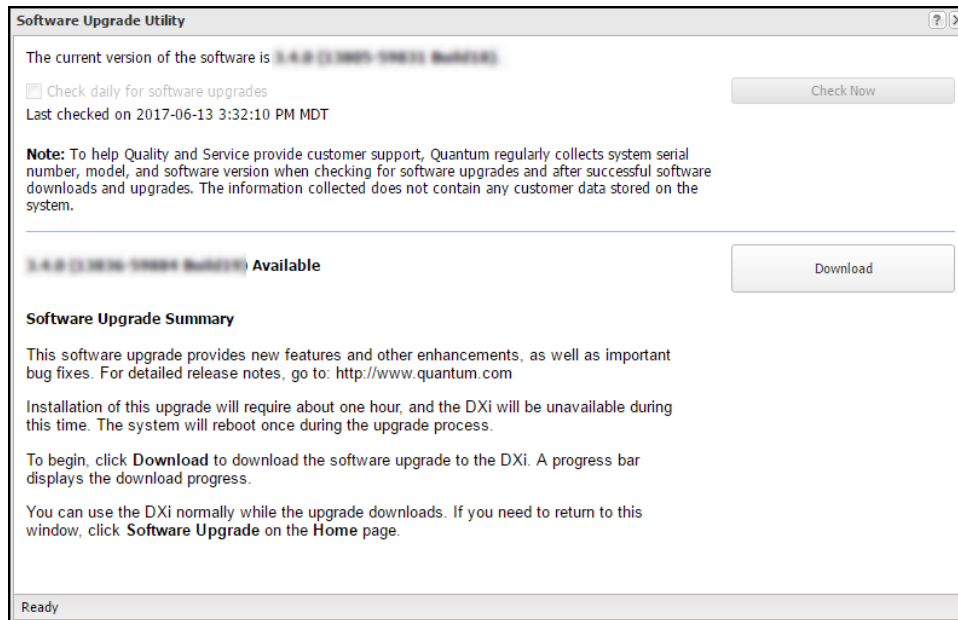
To download and install an available software upgrade:

1. On the **Software Upgrade Utility**, click **Download**.

The bottom status bar displays download progress. It will take several minutes to download the upgrade, depending on network speeds. You can use the DXi normally while the upgrade downloads. If you need to return to this window, click **Software Upgrade** on the **Home** page.

When the download is complete, a list of pre-upgrade actions displays (see [Figure 4 on the next page](#)). These are important actions you should take prior to installing the upgrade.



**Figure 4:** Software Upgrade Utility - Software Upgrade Downloaded

2. To ensure the system is healthy before upgrading, read and follow the instructions in each of the pre-upgrade actions. The pre-upgrade actions can differ depending on the type of upgrade, but typical actions include the following:
  - Address and delete all outstanding administration alerts.
  - Resolve and close all outstanding service tickets.

---

**i Note:** Quantum recommends taking the following actions before upgrading.

- Stop all active backup jobs (see your backup application). Any backup jobs that are run during the upgrade will fail.
  - Make sure all replication jobs are complete. If replication or synchronization jobs are nearly complete, Quantum recommends allowing them to complete before upgrading.
  - Make sure space reclamation is complete. If space reclamation is nearly complete, Quantum recommends allowing it to complete before upgrading.
  - Download a system diagnostics file and transfer the file to a safe repository off of the DXi. The system diagnostics file can help in resolving problems if they occur.
3. Confirm that you have completed all pre-upgrade actions by selecting the **Ready to install** check box.
 

---

**i Note:** The **Ready to install** check box and the **Install** button are disabled if there are any outstanding administration alerts or service tickets.
  4. To begin the upgrade process, click **Install**.

Read the onscreen information to learn what to expect during the upgrade. The bottom status bar displays installation progress, and a message displays if a reboot is required.

Depending on the type of upgrade, the DXi may be placed in service mode for about an hour. While in service mode, the system will shut down all backup and replication services. If necessary, the DXi will restart one or more times to complete the upgrade.

**i Note:** If you decide not to install the software upgrade after downloading it, click **Remove Software Upgrade File** to remove the current download from the DXi.

### Important - Clear Your Web Browser Cache

It is important to clear your Web browser cache before logging on to the remote management console for the first time following the software upgrade. This will ensure the remote management console displays correctly.

## Uploading a Software Upgrade File

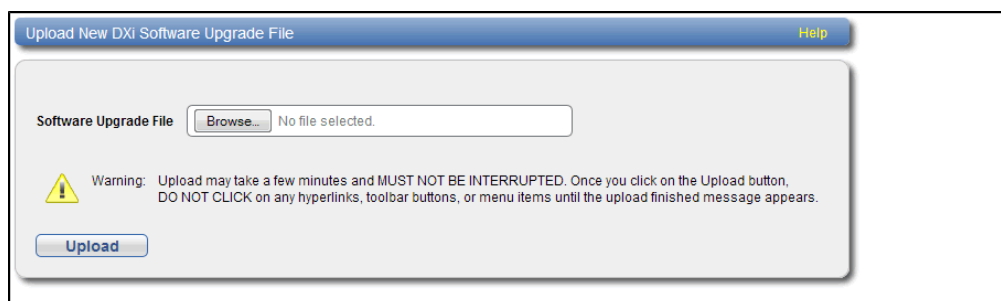
The **Software Upgrade** page allows you to upload and install a software upgrade file on the Veeam. Use this upgrade method if the DXi cannot access the Internet.

Before you begin, download the software upgrade file on a computer connected to the Internet, and then copy the software upgrade file (.fw) to the computer you will use to access the DXi remote management console. You can download the software upgrade file and release notes from the Quantum Service and Support Web site:

<http://www.quantum.com/ServiceandSupport/Index.aspx>

To access the **Software Upgrade** page, click the **Utilities** menu, and then click the **Software Upgrade** tab (see [Figure 5 below](#)).

**Figure 5:** Software Upgrade Page



To upload a software upgrade file:

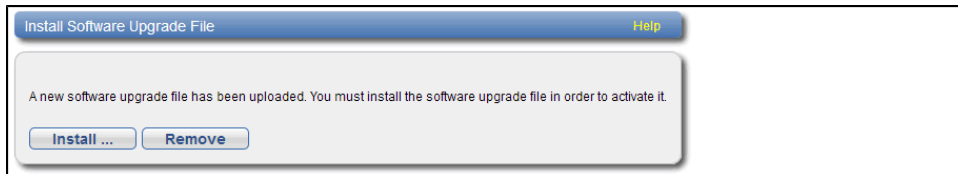
1. Click the **Browse** button to browse the system and locate the software upgrade file.
2. Click **Upload**.
3. Click **Start** to begin the upload process.

Do not close the window until the uploading and unpacking process is complete. An **Information** message displays stating the software upgrade file was uploaded successfully.

4. Click **OK**.

The **Software Upgrade** page indicates that a software upgrade file has been uploaded (see [Figure 6 below](#)).

**Figure 6:** Software Upgrade Page - Software Upgrade File Uploaded

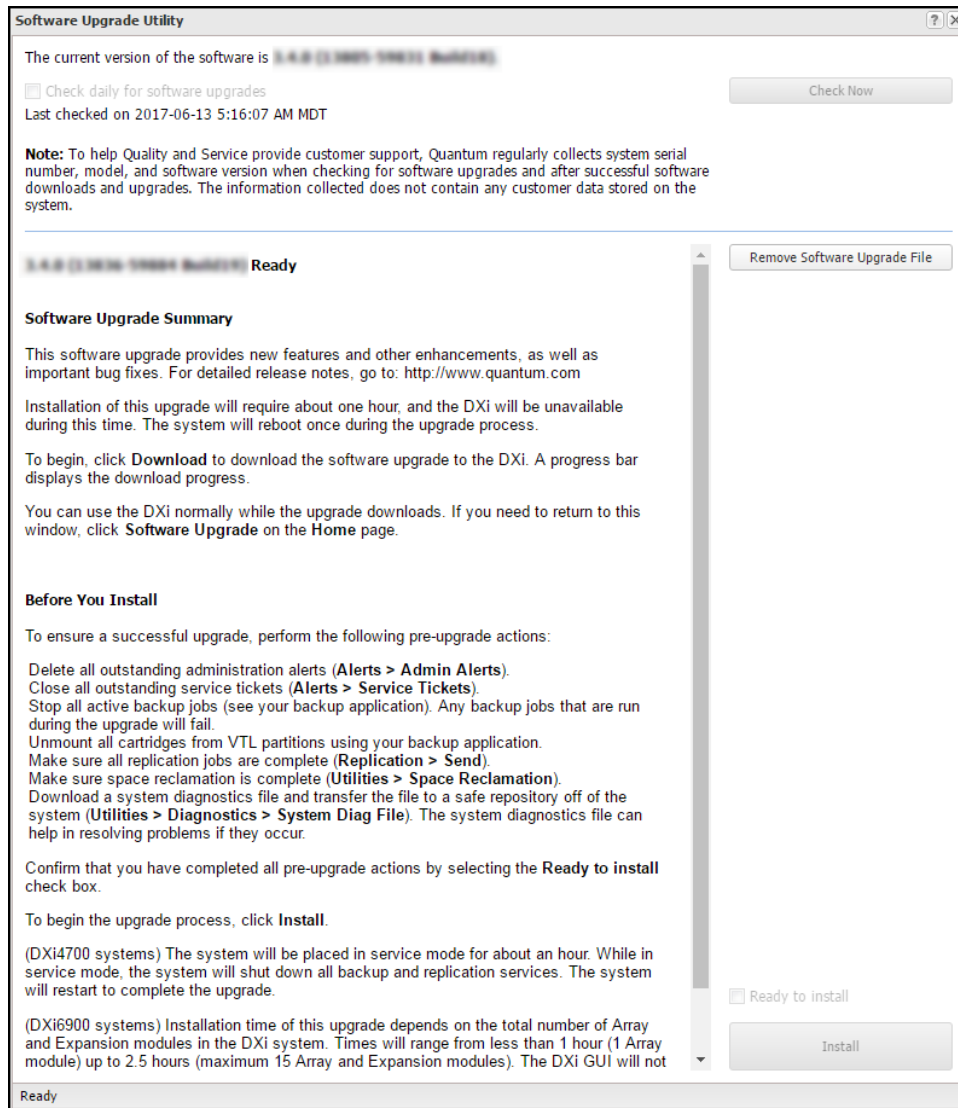


5. Click **Install**.

#### **Additional Information**

- If necessary, click the link to delete any outstanding administration alerts before proceeding.
- If you decide not to install the software upgrade file after uploading it, click **Remove** on the **Utilities > Software Upgrade** page to remove the uploaded software upgrade file from the DXi.

The **Software Upgrade Utility** displays (see [Figure 7 on the next page](#)).

**Figure 7: Software Upgrade Utility - Software Upgrade File Uploaded**

6. To ensure the system is healthy before upgrading, read and follow the instructions in each of the pre-upgrade actions. The pre-upgrade actions can differ depending on the type of upgrade, but typical actions include the following:
- Address and delete all outstanding administration alerts.
  - Resolve and close all outstanding service ticket.

**Note:** Quantum recommends taking the following actions before upgrading.

- Stop all active backup jobs (see your backup application).
  - Make sure all replication jobs are complete. If replication or synchronization jobs are nearly complete, Quantum recommends allowing them to complete before upgrading.
  - Make sure space reclamation is complete. If space reclamation is nearly complete, Quantum recommends allowing it to complete before upgrading.
  - Download a system diagnostics file and transfer the file to a safe repository off of the DXi. The system diagnostics file can help in resolving problems if they occur.
7. After you have completed all pre-upgrade actions, confirm that you are ready to continue by selecting the **Ready to install** check box.

**i Note:** The **Ready to install** check box and the **Install** button are disabled if there are any outstanding administration alerts or service tickets.

8. To begin the upgrade process, click **Install**.

Read the on-screen information to learn what to expect during the upgrade. The bottom status bar displays installation progress, and a message displays if a reboot is required.

Depending on the type of upgrade, the DXi may be placed in service mode for about an hour. While in service mode, the system will shut down all backup and replication services. If necessary, the DXi will restart one or more times to complete the upgrade.

### Important - Clear Your Web Browser Cache

It is important to clear your Web browser cache before logging on to the remote management console for the first time following the software upgrade. This will ensure the remote management console displays correctly.

## Install Additional Memory

**⚠ WARNING:** The DXi system **must** be running DXi 3.4.0 Software or higher before installing additional memory (see [Software Upgrades on page 5](#)).

A DXi system may require the installation of additional memory modules to support Veeam. Please review the tables below to verify if the DXi requires additional memory.

If the DXi already has the correct memory configuration, continue to [Install the Veeam License on page 29](#).

### Additional Information

Before beginning the replacement procedure, make sure that you have the required replacement kit. The appropriate memory module kit will be provided by Quantum Customer Support.

You will need the following items to perform this procedure:

- Replacement memory module kit provided by Quantum Customer Support.
- ESD grounding wrist strap (included in the replacement kit)

**Table 1:** DXi4700 Veeam Memory Module Installations

| Current Capacity | Current Memory | Current DIMM Configuration | Veeam Memory Installation  | Total New Memory | Procedure   |
|------------------|----------------|----------------------------|--|------------------|---|
| 5-27 TB          | 32 GB          | 8 x 4 GB                   | <ul style="list-style-type: none"> <li>• Install 8 x 4 GB</li> </ul> | 64 GB            | <ol style="list-style-type: none"> <li>1. <a href="#">Turn off the DXi on page 16</a></li> <li>2. <a href="#">Open the Node Cover on page 16</a></li> <li>3. <a href="#">Install a Memory Module on page 22</a></li> <li>4. <a href="#">Close the Node Cover on page 24</a></li> <li>5. <a href="#">Turn on the DXi on page 27</a></li> </ol> |
| 45-99 TB         | 64 GB          | 16 x 4 GB                  | <ul style="list-style-type: none"> <li>• Install 8 x 4 GB</li> </ul> | 96 GB            | <ol style="list-style-type: none"> <li>1. <a href="#">Turn off the DXi on page 16</a></li> <li>2. <a href="#">Open the Node Cover on page 16</a></li> <li>3. <a href="#">Install a Memory Module on page 22</a></li> <li>4. <a href="#">Close the Node Cover on page 24</a></li> <li>5. <a href="#">Turn on the DXi on page 27</a></li> </ol> |

| Current Capacity | Current Memory | Current DIMM Configuration | Veeam Memory Installation   | Total New Memory | Procedure   |
|------------------|----------------|----------------------------|---|------------------|---|
| 117-135 TB       | 96 GB          | 24 x 4 GB                  | <ul style="list-style-type: none"> <li>Remove 8 x 4 GB</li> <li>Install 8 x 8 GB</li> </ul> | 128 GB           | <ol style="list-style-type: none"> <li><a href="#">Turn off the DXi on the next page</a></li> <li><a href="#">Open the Node Cover on the next page</a></li> <li><a href="#">Remove a Memory Module on page 20</a></li> <li><a href="#">Install a Memory Module on page 22</a></li> <li><a href="#">Close the Node Cover on page 24</a></li> <li><a href="#">Turn on the DXi on page 27</a></li> </ol> |

**Table 2:** DXi6900 Veeam Memory Module Installations

| Current Capacity | Current Memory | Current DIMM Configuration | Veeam Memory Installation   | Total New Memory | Procedure  |
|------------------|----------------|----------------------------|---|------------------|--|
| 34-102 TB        | 128 GB         | 8 x 16 GB                  | <ul style="list-style-type: none"> <li>Install 8 x 16 GB</li> </ul> | 256 GB           | <ol style="list-style-type: none"> <li><a href="#">Turn off the DXi on the next page</a></li> <li><a href="#">Open the Node Cover on the next page</a></li> <li><a href="#">Install a Memory Module on page 22</a></li> <li><a href="#">Close the Node Cover on page 24</a></li> <li><a href="#">Turn on the DXi on page 27</a></li> </ol> |

**i Note:** DXi6900-S systems and DXi600 G1/G2 systems with 136-510 TB do not require additional memory.

## Turn off the DXi

Before shutting down the DXi, make sure that all backup and replication jobs are finished, and that space reclamation activity is complete.

1. Shut down the system from the remote management console using the **Shutdown** option on the **Utilities > Reboot & Shutdown** page.

---

**i Note:** Shutting down the system can take up to 15 minutes. Only the Node will completely shut down.

2. After the Node shuts down, turn off both power switches on the back of each Array module (DXi6900) or Expansion modules (DXi4700). Wait until the seven segment display on the rear of the module turns off.
3. (DXi6900 only) Turn off both power switches on the back of each Expansion module (EBOD).

## Open the Node Cover

### Additional Information

- You do not need to remove the Node from the rack to remove and replace internal components. Using the DXi sliding rail system, you can pull the Node out on the sliding rails until you have enough space to remove the Node chassis top and access the internal components.
- **IMPORTANT:** If you leave the Node in the rack, you still must disconnect both power cables from the Node prior to opening the Node cover.

To remove the DXi Node from the rack and remove the top cover:

1. Shut down the DXi Node (see [Turn off the DXi above](#)).
2. If installed, remove the front bezel from the Node by lifting the latch on the left side of the bezel.
3. Remove all power, SAS, Ethernet, and Fibre Channel cables from the rear of the Node. Make sure to label the cables so they can be easily identified when they are re-connected to the Node after the replacement procedure is complete.
4. Press the locking tab on either side of the Node, and pull the Node out from the rack until the inner rails lock.

---

**⚠ Caution:** Do not use excessive force when pulling the chassis forward to fully extend the Node or Expansion Module in the rack rails. Using excessive force could bypass the slide rail stop mechanism.

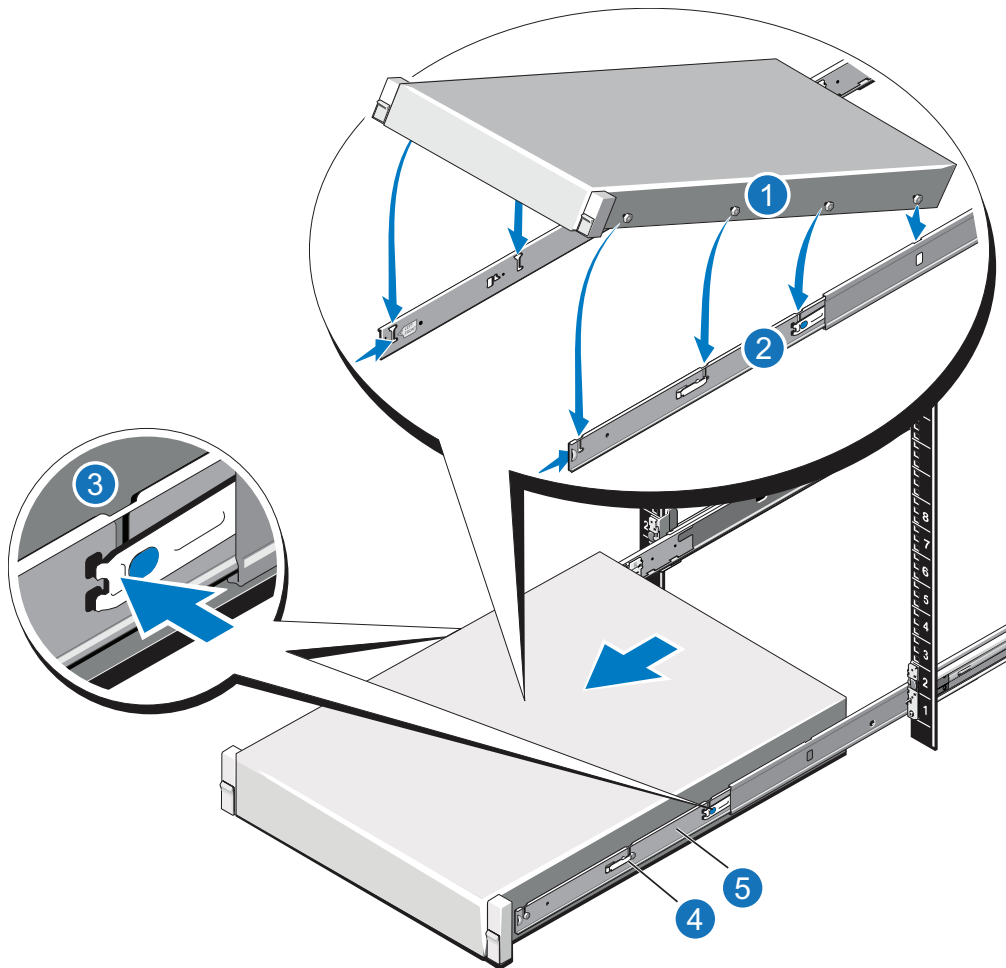
---

**i Note:** If necessary, remove the optional screws securing the Node to the front of the rack (behind the locking tab).

5. Locate the lock levers on the sides of the inner rails (see [Figure 8 on the next page](#)). Unlock each lever by rotating it up to its release position.



**Figure 8:** Removing the DXi Node from the Rack



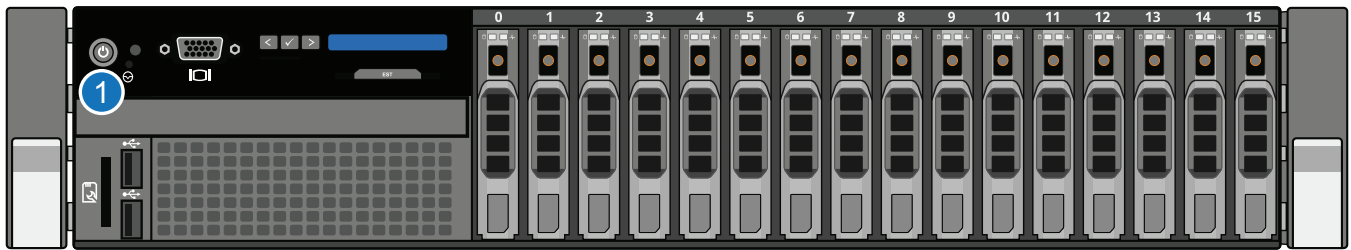
| Item | Description               |
|------|---------------------------|
| 1    | Rear rail standoffs       |
| 2    | Rear rail J-slots         |
| 3    | Slide-release lock button |
| 4    | Lock lever                |
| 5    | Inner slide rails         |

- Grasp the sides of the Node firmly and pull it forward until the rail standoffs are at the front of the J-slots.
- Lift the Node up and away from the rack and place it on a level surface.

**WARNING:** A minimum of two people are required to lift the DXi node chassis.

- Press and hold the power button on the front of the Node for three seconds to fully drain the system of stored power prior to removing the cover (see [Figure 9 on the next page](#)).

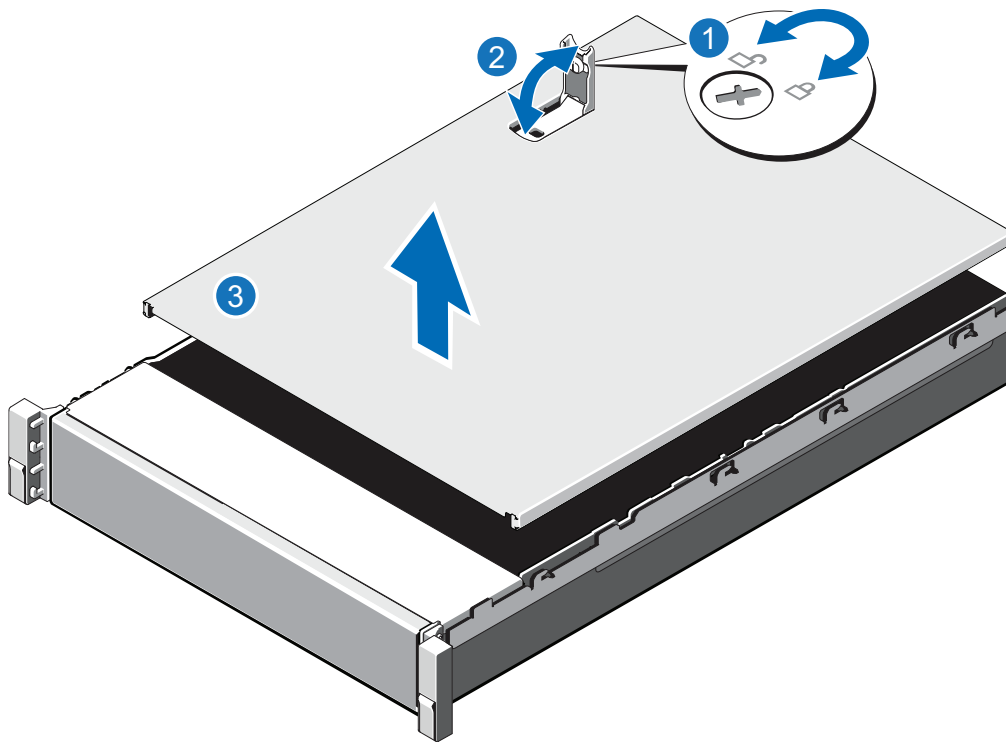
**Figure 9:** DXi6900 Node Power Button



**1. Power Switch**

9. On the Node cover, rotate the latch release lock counterclockwise to the unlocked position (see [Figure 10 below](#)).

**Figure 10:** Removing the Node Cover

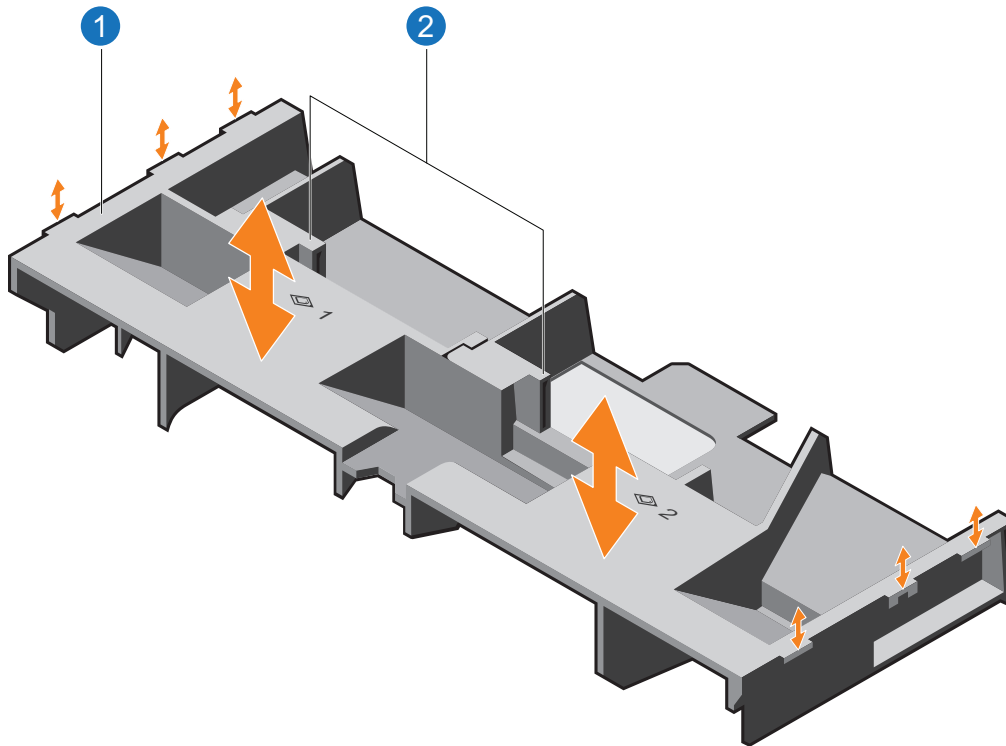


| Item | Description        |
|------|--------------------|
| 1    | Latch release lock |
| 2    | Latch              |
| 3    | Node cover         |

10. Lift the latch on top of the Node and slide the cover back.

11. Grasp the cover on both sides, and carefully lift the cover away from the Node.
12. Remove the cooling shroud by holding the touch points and lifting the shroud away from the Node (see [Figure 11 below](#)).

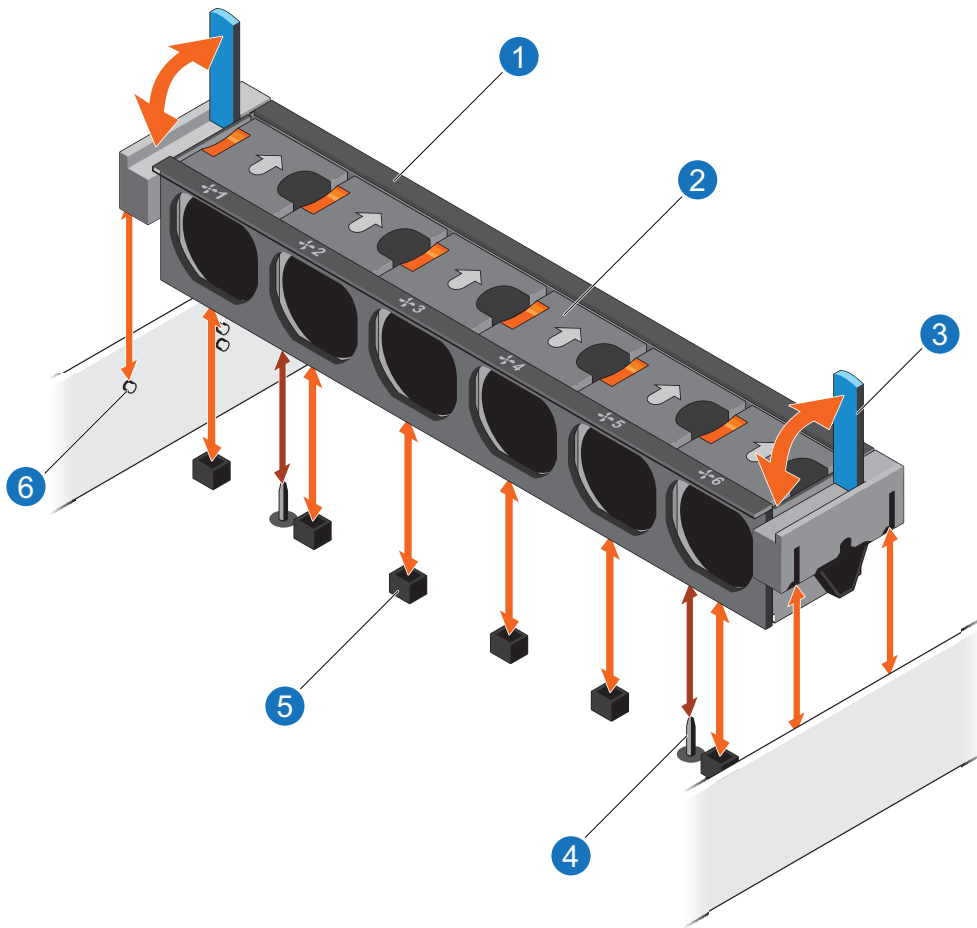
**Figure 11:** Removing and Replacing the Cooling Shroud



| Item | Description    |
|------|----------------|
| 1    | Cooling shroud |
| 2    | Touch point    |

13. If you are replacing memory modules, remove the cooling-fan assembly by lifting the release levers upwards.

**Figure 12:** Removing the Cooling Fan Assembly



| Item | Description                       |
|------|-----------------------------------|
| 1    | Cooling-fan assembly              |
| 2    | Cooling fan                       |
| 3    | Release lever (2)                 |
| 4    | Guide pin on the system board (2) |
| 5    | Cooling-fan connector (6)         |
| 6    | Guide pin on the chassis (6)      |

14. Lift the cooling-fan assembly out of the Node.

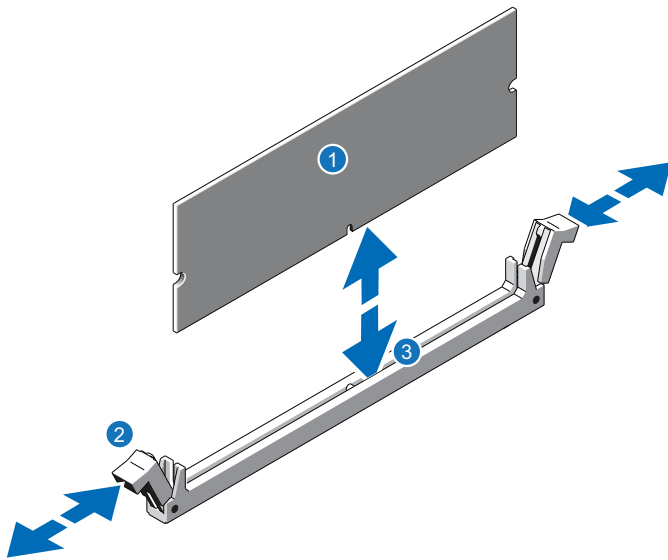
## Remove a Memory Module

To remove a memory module from the DXi Node:

**WARNING:** The memory modules are hot to the touch for some time after the system has been powered down. Allow time for the memory modules to cool before handling them.

1. Locate the memory module.
2. Press down and out on the ejectors on each end of the socket until the memory module pops out of the socket (see [Figure 13 below](#)).

**Figure 13:** Removing and Installing a Memory Module



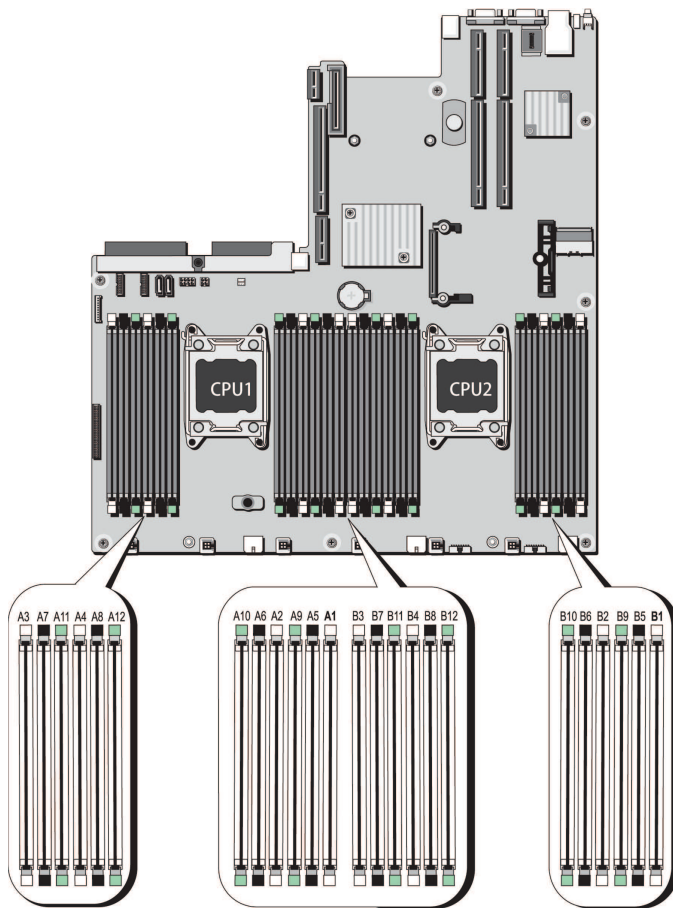
| Item | Description           |
|------|-----------------------|
| 1    | Memory module         |
| 2    | Ejector latch         |
| 3    | Socket alignment tool |

### DXi4700 Memory Removal Order

**Note:** Removing memory from the DXi4700 is only necessary if the system currently has 96 GB of memory.

| Current                 | With Veeam | Memory Installation  |
|-------------------------|------------|--|
| 96 GB<br>All slots full | 128 GB     | Remove 8 x 4 GB memory modules in slots A1-A4 and from slots B1-B4 (see <a href="#">Figure 14 on the next page</a> ) |

**Figure 14:** DXi Memory Slots



## Install a Memory Module

To install a memory module in the DXi Node:

**⚠ Caution:** Handle the memory modules by the card edges and avoid touching the components on the memory module.

1. Align the memory module's edge connector with the alignment key of the memory module socket, and insert the memory module in the socket (see [Figure 13 on the previous page](#)).

**i Note:** The memory module socket has an alignment key that allows you to install the memory module in the socket in only one way.

2. Press down on the memory module with your thumbs until the ejector latches snap into a locked position.

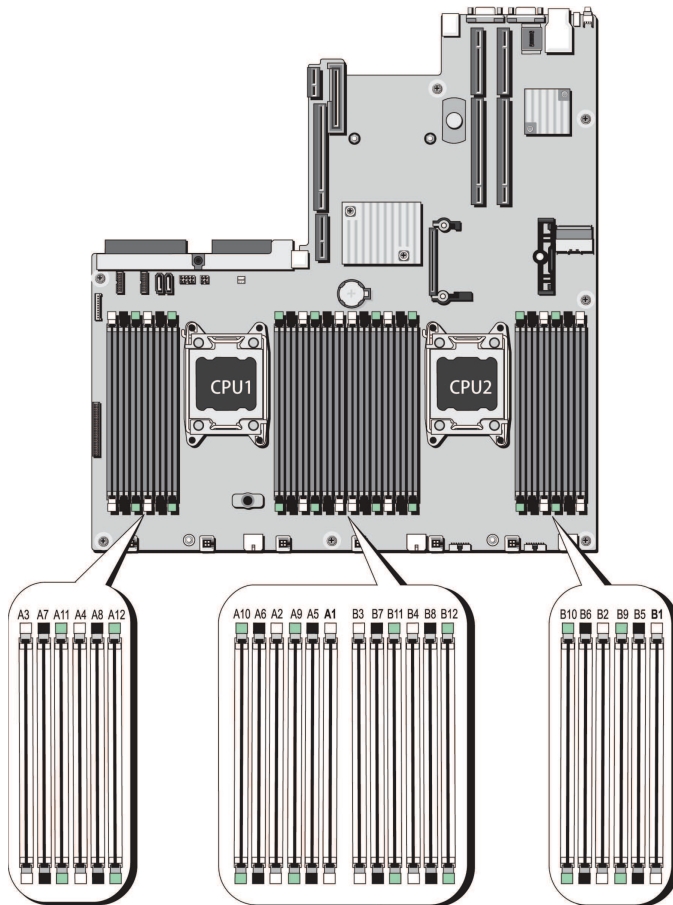
### DXi4700 Memory Installation Order

| Current | With Veeam | Memory Installation  |
|---------|------------|--|
| 32 GB   | 64 GB      | Install 8 x 4 GB memory modules in slots A5-A8 and B5-B8 (see <a href="#">Figure 15 below</a> ).   |
| 64 GB   | 96 GB      | Install 8 x 4 GB memory modules in slots A9-A12 and B9-B12 (see <a href="#">Figure 15 below</a> ). |
| 96 GB   | 128 GB     | Install 8 x 8 GB memory modules in slots A1-A4 and B1-B4 (see <a href="#">Figure 15 below</a> ).   |

### DXi6900 Memory Installation Order

| Current | With Veeam | Memory Installation   |
|---------|------------|---|
| 128 GB  | 256 GB     | Install 8 x 16 GB memory modules in slots A5-a8 and B5-B8 (see <a href="#">Figure 15 below</a> ). |

Figure 15: DXi Memory Slots

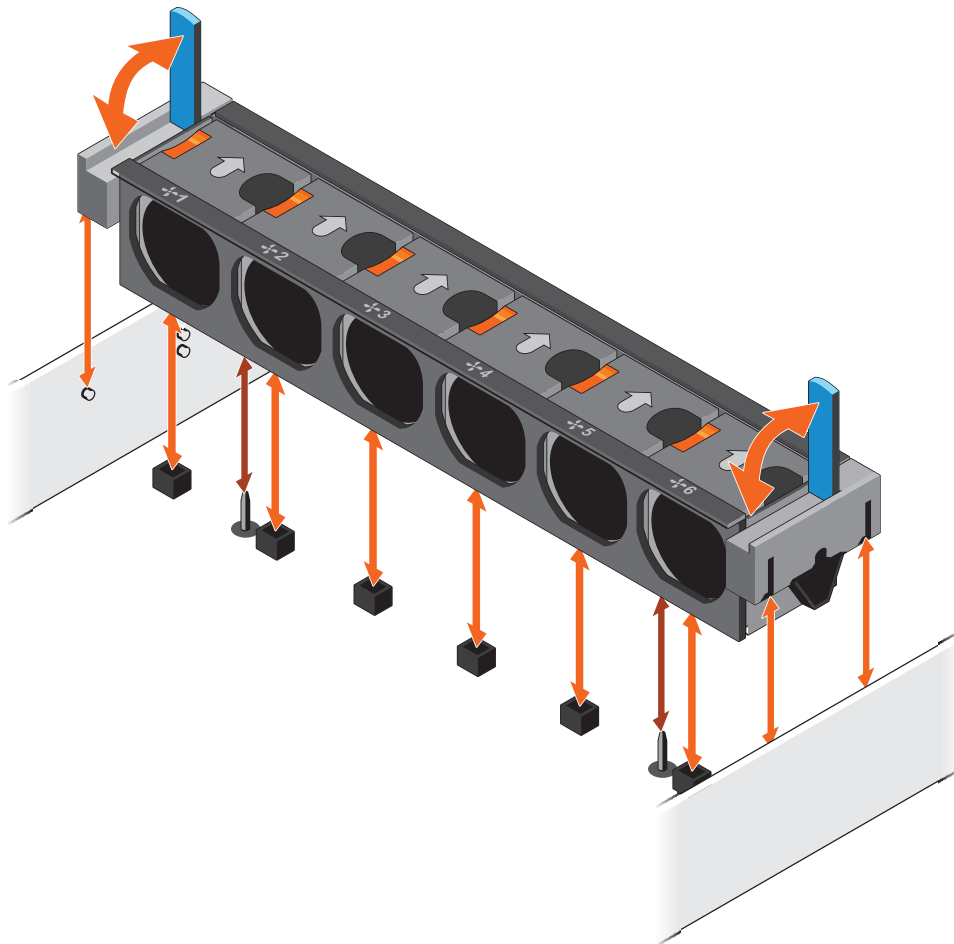


## Close the Node Cover

To replace the Node cover and return the Node to the rack after completing the memory module installation:

1. Replace the cooling-fan assembly:
  - a. Align the cooling-fan assembly slots with the guide pins on the chassis (see [Figure 16 below](#)).
  - b. Slide the cooling-fan assembly into the chassis.
  - c. Lock the cooling-fan assemble into the chassis.

**Figure 16:** Replacing the Cooling-Fan Assembly

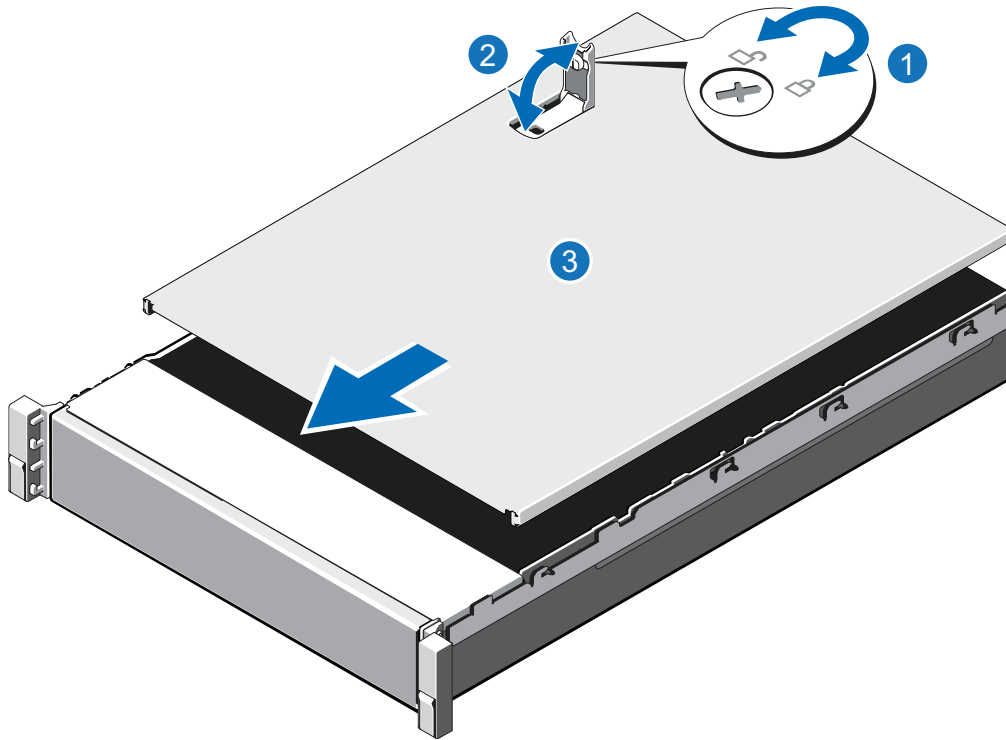


2. Replace the cooling shroud:
  - a. Align the tabs on the cooling shroud with the securing slots on the chassis (see [Figure 11 on page 19](#)).
  - b. Lower the cooling shroud into the chassis until it is firmly seated.

**i Note:** For proper seating of the cooling shroud in the chassis, ensure that the cables inside the system are routed along the chassis

3. Lift the latch on the cover (see [Figure 17 on the next page](#)).

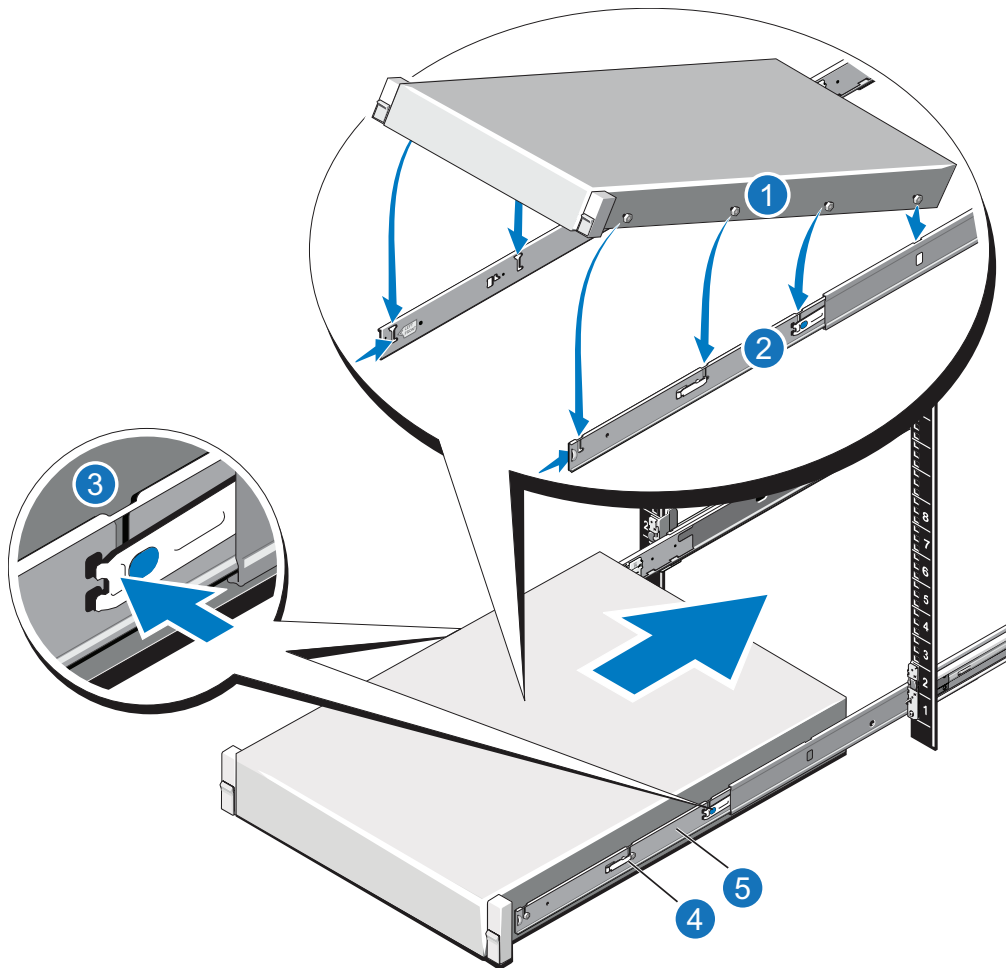


**Figure 17:** Replacing the Node Cover

| Item | Description        |
|------|--------------------|
| 1    | Latch release lock |
| 2    | Latch              |
| 3    | Node cover         |

- Place the cover onto the Node chassis and offset the cover slightly back so that it clears the chassis hooks and lays flush on the chassis.
- Push down the latch to move the cover into the closed position.
- Rotate the latch release lock in a clockwise direction to secure the cover.
- Pull the inner slide rails out of the rack until they lock into place (see [Figure 18 on the next page](#)).

**Figure 18:** Installing the DXi6900-S Node in the Rack



| Item | Description               |
|------|---------------------------|
| 1    | Rear rail standoffs       |
| 2    | Rear rail J-slots         |
| 3    | Slide-release lock button |
| 4    | Lock lever                |
| 5    | Inner slide rails         |

8. Locate the rear rail standoff on each side of the system and lower them into the rear J-slots on the slide assemblies.
9. Rotate the Node downward until all the rail standoffs are seated in the J-slots.
10. Push the Node inward until the lock levers click into place.
11. Press the slide-release lock buttons on both rails and slide the Node into the rack.

12. Reconnect all power, SAS, Ethernet, and Fibre Channel cables on the rear of the Node.
13. If applicable, replace the front bezel. Insert the right side of the bezel into the slots on the right side of the Node, then snap the left side of the bezel into place.

## Turn on the DXi

### Turn on the DXi4700

To turn on the system:

1. Turn on the Veeam system components in the following order:
  - a. Turn on both power switches on the back of each Expansion module (see [Figure 19 below](#)). Wait 30 seconds for the Expansion modules to initialize. Verify on the front panel that the modules have power and there were no hard drive failures (Drive status indicator on hard drive blinks amber four times per second).

**Figure 19:** Expansion Module Power Switches



#### 1 - Power Switches

- b. Press the power button on the front of the Node (see [Figure 20 below](#)). Wait for the system to boot before continuing with the procedure. (This can take up to 30 minutes.)

**i Note:** The system may reboot one or more times depending on the components that were installed. If all components are properly installed and cabled, the LEDs on all hard drives in the Node and the Expansion modules will be lit. (The top LED will be solid and the bottom LED will blink.)

**Figure 20:** Node Power Button



#### 1 - Power Button

### Turn on the DXi6900

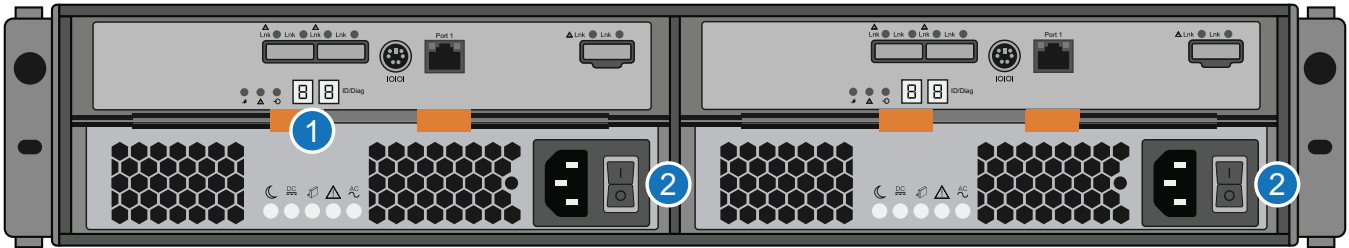
To turn on the system, power on the DXi6900 system components in the following order:

1. Turn on both power switches on the back of each Expansion module (EBOD) (see [Figure 21 below](#)). Wait until the seven segment display on the rear of the module displays **00** (approximately 1 minute).
2. Turn on both power switches on the back of each Array module (RBOD) (see [Figure 22 below](#)). Wait until the seven segment display on the rear of the module displays **99** (approximately 3 minutes).
3. Press the power button on the front of the Node (see [Figure 23 below](#)). Wait for the system to boot before attempting to log on.

**i Note:** The system can take approximately 30 minutes to start up, depending on the amount of installed storage capacity.

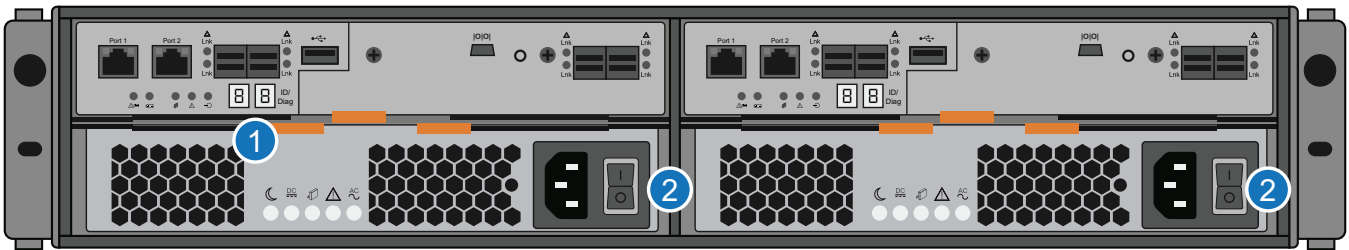
The system is now ready for operation.

**Figure 21:** Powering on the DXi6900 Expansion Modules (EBODs)



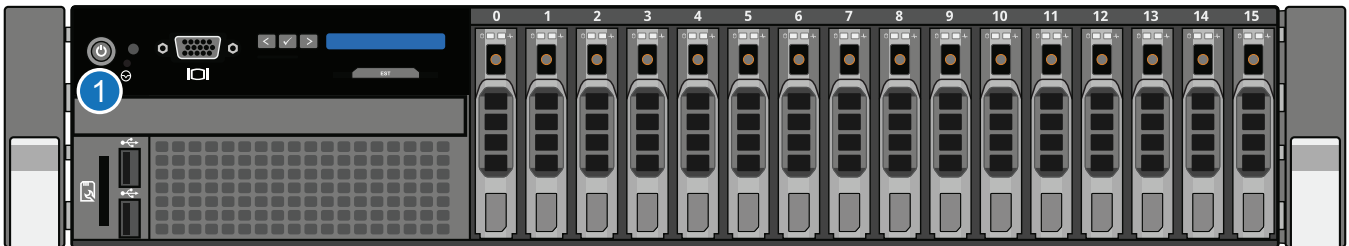
1. Seven Segment Display
2. Power Switches

**Figure 22:** Powering on the DXi6900 Array Modules (RBODs)



1. Seven Segment Display
2. Power Switches

**Figure 23:** Powering on the DXi6900 Node



## 1. Power Switch

# Install the Veeam License

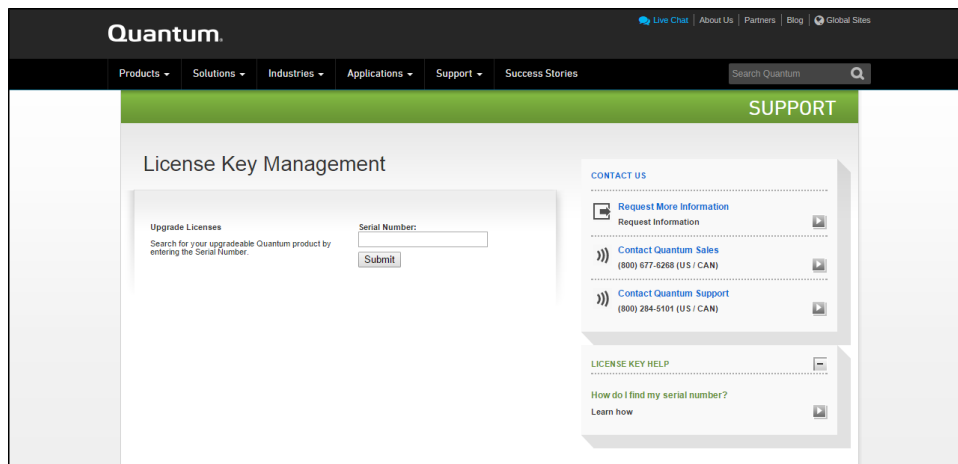
To enable Veeam functionality, a Veeam License Key must be installed on the DXi system. The appropriate Veeam License Certificate is provided by Quantum during a new product installation or product upgrade. This certificate will contain an authorization code.

To add a Veeam license key, perform the following steps:

1. Open a Web browser on a computer with Internet access.
2. Enter <http://www.quantum.com/licensekeys> in the browser address box.

The **License Key Management** page displays (see [Figure 24 below](#)).

**Figure 24:** License Key Management Page



3. Enter the DXi system serial number in the **Serial Number** box and click **Submit**.

The **Licensed Feature** page displays.

**Note:** The serial number displays on the **License Keys** page, above the **New Key** box.

4. Enter the authorization code (printed on the Veeam License Certificate) and click **Get License Key**.  
The **Licensed Feature** page returns a license key. Print out or write down the license key, or save it to a text file.
5. Access the DXi remote management console.
6. Click the **Utilities** menu, and then click the **License Keys** tab.  
The **License Keys** page displays.
7. Enter the Veeam license key in the **New Key** box, and then click **Add**.  
The Veeam license key is added to the system.

# Create a NAS Share

You must create a Veeam NAS share to present the storage capacity of the DXi.

To add a NAS share:

1. In the DXi remote management console, select **Configuration > NAS**. The **NAS Summary** page displays (see [Figure 25 below](#)).

**Figure 25:** NAS Summary Page

| Share Name    | Protocol             | Export Path             | Permissions  | Access    | Deduplication | Replication                | Targets       | Description |
|---------------|----------------------|-------------------------|--------------|-----------|---------------|----------------------------|---------------|-------------|
| testAppSpec1  | Application Specific | testAppSpec1            | Read & Write |           | Enabled       | Send Sync ID: testAppSpec1 | 10.40.166.123 |             |
| testNfs1      | NFS (sync)           | /Q/shares/testNfs1      | Read Only    | All hosts | Disabled      | N/A                        |               |             |
| testNfsShare1 | NFS (sync)           | /Q/shares/testNfsShare1 | Read & Write | All hosts | Enabled       | <a href="#">Configure</a>  |               |             |

2. Click **Add**.

The **Add NAS Share** page displays (see [Figure 26 below](#)).

**Figure 26:** Add NAS Share Page

### NAS Share Settings

\* Name:

Description:

Options

Hide from network browsing

Enable deduplication  
Cannot enable/disable deduplication once share is created.

Export Protocol

CIFS (Windows network)

NFS (UNIX/Linux network)

\* Required Field

### Replication Settings

Send

Enable replication to the replication target DXi

Enable Directory/File Based replication to target

Sync ID:

| Replication Target DXIs          | Status        | Encryption  |
|----------------------------------|---------------|-------------|
| <input type="checkbox"/> 10. ... | Ready         | AES 256-bit |
| <input type="checkbox"/> 10. ... | System Paused | AES 256-bit |

Receive


Enable Directory/File Based replication to this DXi

Sync ID:

Access:  Locked  Unlocked

Buttons:

3. Under **NAS Share Settings**, enter information about the share:

|                                   |  |
|-----------------------------------|--|
| <b>Name</b>                       | Enter the name of the Veeam NAS share.   |
| <b>Description</b>                | (Optional) Enter a brief description of the share.   |
| <b>Protocol</b>                   | Select the NFS option to use the share on a UNIX or Linux network.<br><br> <b>Note:</b> CIFS/SMB is not currently supported for Veeam NAS shares. |
| <b>Hide from network browsing</b> | Do not select. This is for CIFS/SMB shares only.   |
| <b>Enable deduplication</b>       | Select the check box. Veeam NAS shares must have deduplication enabled.  |

4. Click **Apply**.

## Enable Veeam on the DXi

Once the Veeam license is installed and a VM NAS share created, enable Veeam on the DXi.

In the DXi remote management console, select **Configuration > System > App Environment**. The **Application Environment** page displays.

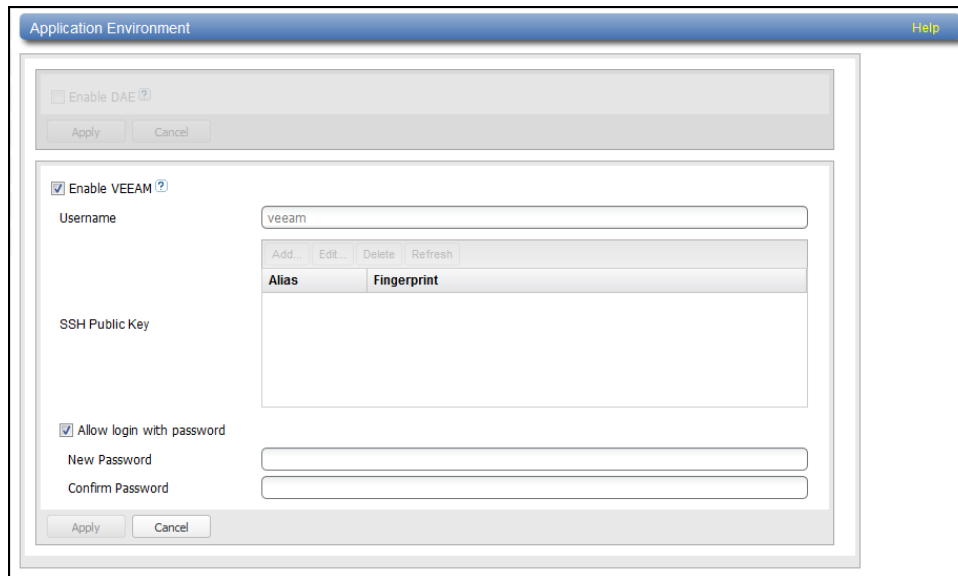
### Enabling Veeam

- When enabling Veeam for the first time, a password will be required.
- Public keys cannot be configured until after Veeam has been enabled and the system has been rebooted.

To enable Veeam:

1. Select the **Enable Veeam** check box (see [Figure 27 below](#)).

**Figure 27:** Application Environment - Enable Veeam



2. Select the **Allow login with password** check box.
3. Enter the following information:

|                         |   |
|-------------------------|---|
| <b>New Password</b>     | Enter the new password.                     |
| <b>Confirm Password</b> | Enter the new password again to confirm it. |

**Additional Information**

Passwords can be up to 32 characters. Alphanumeric characters and special characters are allowed.

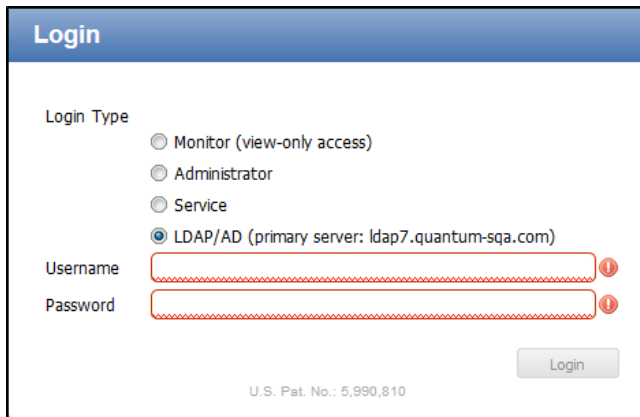
4. Click **Apply**.

A dialog box appears stating that the system will require a reboot. Click **Yes**. The DXi will reboot and the DXi login screen will appear (see [Figure 28 on the next page](#)).

**Note:** The reboot takes approximately 20 minutes to complete.

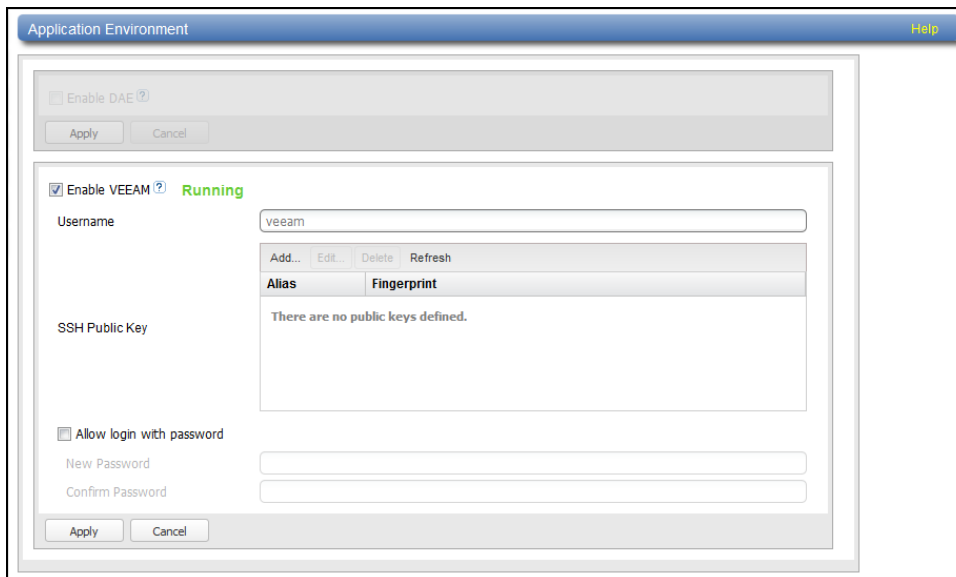


**Figure 28:** Login Window



- 5. Log back into the DXi.
- 6. Navigate back to the **App Specific** page (**Configuration > System > App Specific**). Veeam will now be enabled with a status of **Running** or **Not Running** (see [Figure 29 below](#)).

**Figure 29:** Application Environment - Veeam Enabled

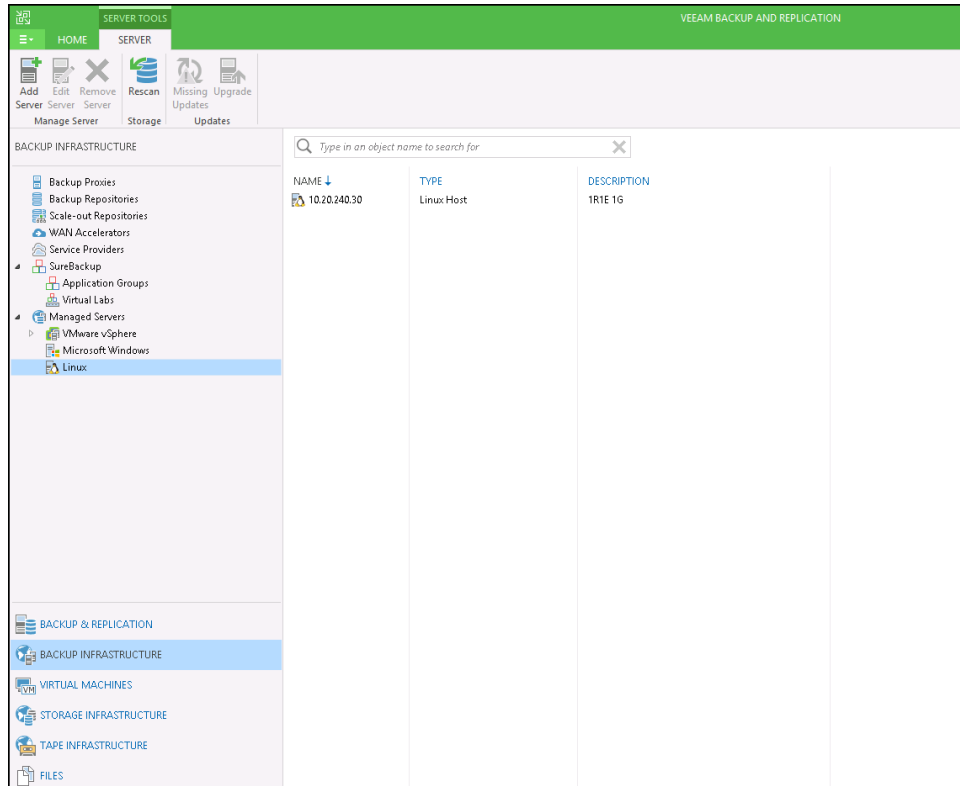


# Veeam Configuration

Once Veeam has been configured enabled on the DXi system, the Linux server within the Veeam Backup and Replication software must be configured. Do the following on the Veeam Linux server:

1. Select **Backup Infrastructure** (see [Figure 30 below](#)).

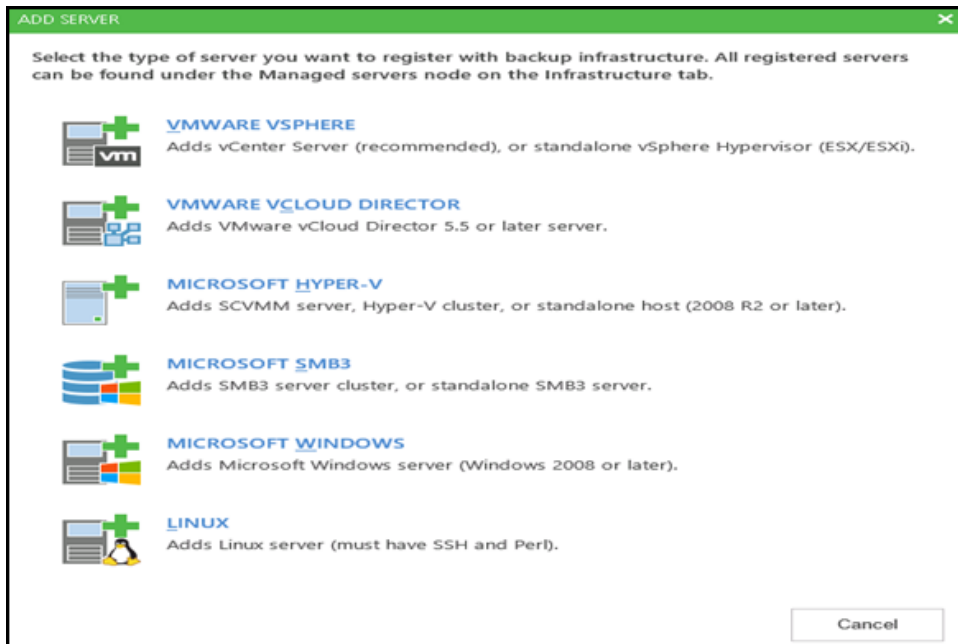
**Figure 30:** Backup Infrastructure



2. Select **Managed Servers > Add Server**.

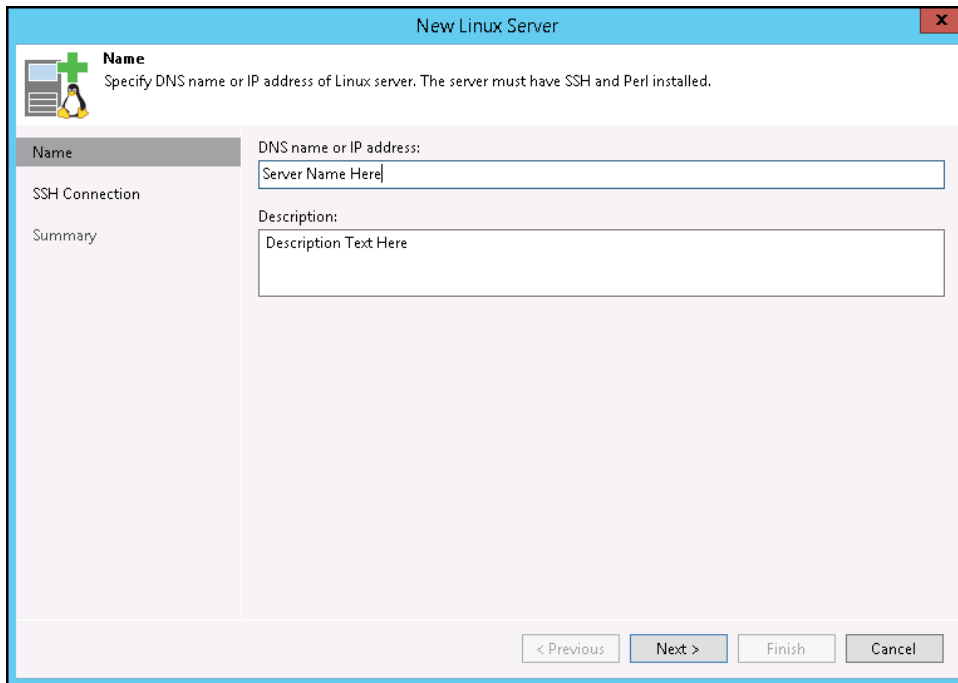
The **Add Server** dialog box appears (see [Figure 31 on the next page](#)).

Figure 31: Add Server

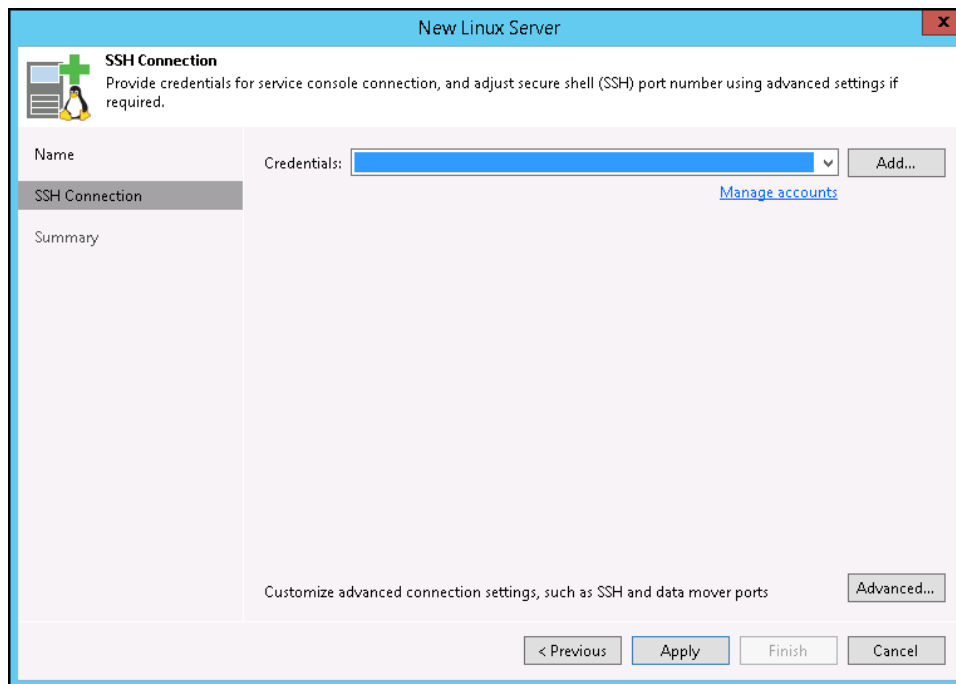


3. Select **Linux**. The New Linux Server dialog box appears (see [Figure 32 below](#))

Figure 32: New Linux Server



4. Enter the **DNS** or **IP Address** of the DXi system configured for Veeam.
5. Click **Next**. The SSH Connection screen appears (see [Figure 33 on the next page](#))

**Figure 33:** New Linux Server - SSH Connection

6. Select **Add > Linux Account**.

The **Credentials** dialog box appears (see [Figure 34 on the next page](#)).

Figure 34: Credentials

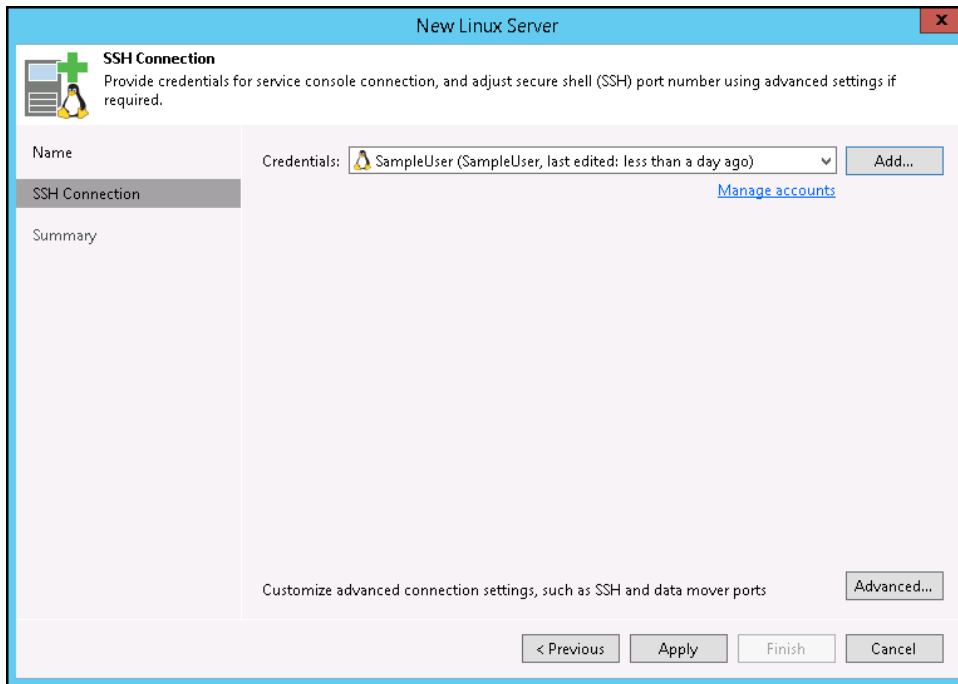
The screenshot shows a 'Credentials' dialog box with the following fields and options:

- Username:** veeam
- Password:** [Masked with 10 dots]
- SSH port:** 22
- Non-root account:**
  - Elevate specified account to root
  - Add account to the sudoers file automatically
- Root password:** [Empty text box]
- Description:** veeam

Buttons: OK, Cancel

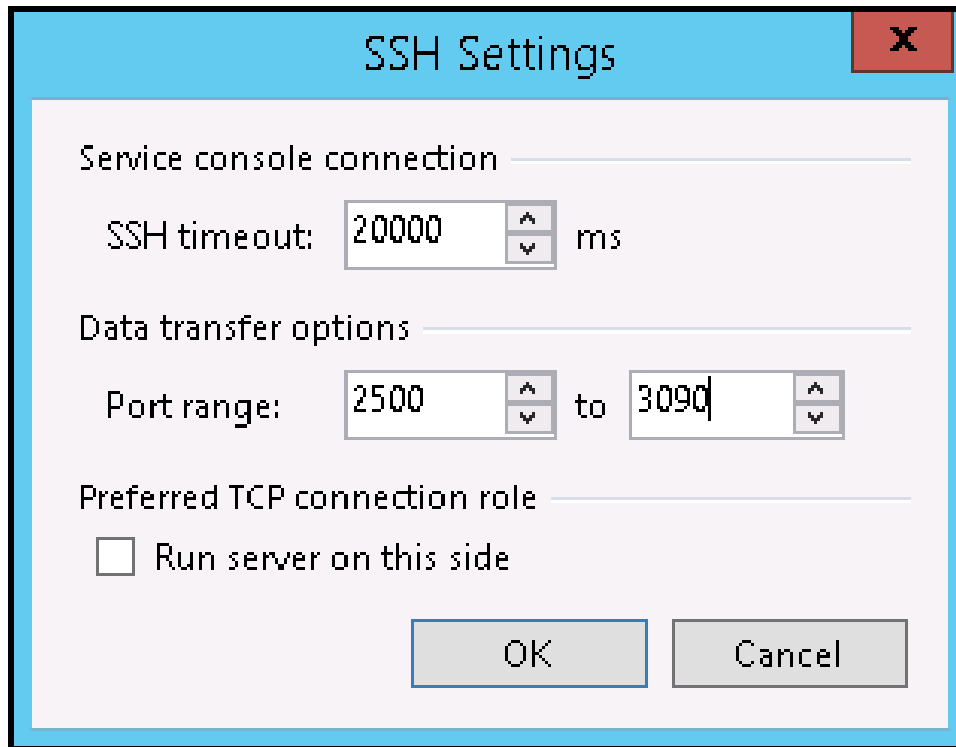
7. Enter the **Username** and **Password** created when enabling Veeam on the DXi (see [Enable Veeam on the DXi on page 31](#)).
8. Click OK. The credentials appear in the New Linux Server - SSH Connection screen (see [Figure 35 on the next page](#)).

**Figure 35: User Credentials Added**



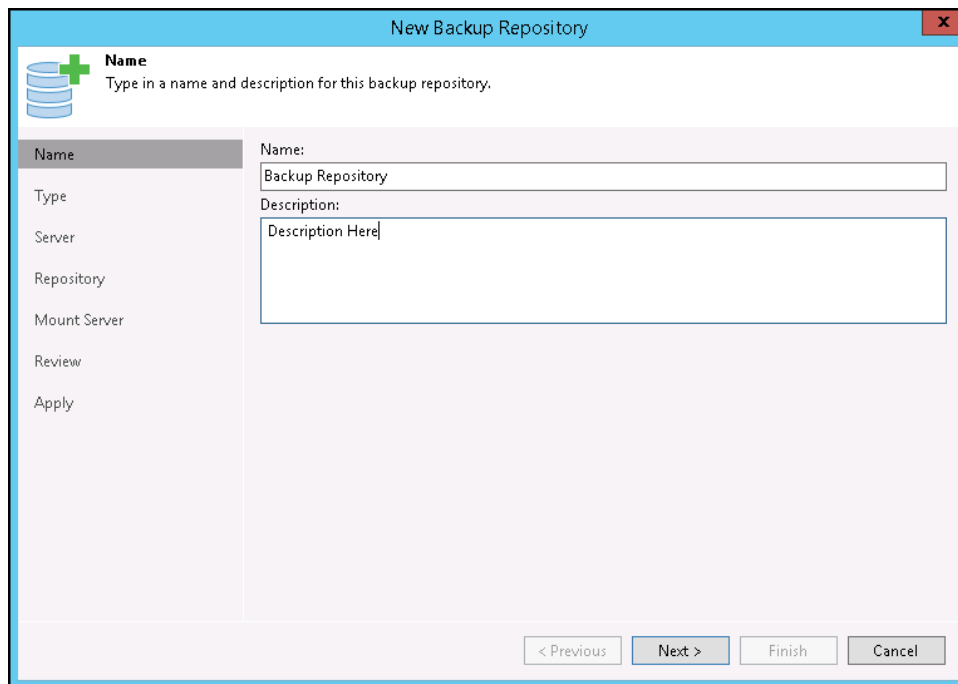
9. Select **Advanced**.

The **SSH Settings** dialog box appears (see [Figure 36 on the next page](#)).

**Figure 36:** SSH Settings

10. Set the **Port range** from 2500 to 3090.
11. Click **OK** to close the **SSH Settings** dialog box.
12. Click **Apply** to close the **New Linux Server** dialog box.\
13. In **Backup Infrastructure**, select **Backup Repositories**> **Add Backup Repositories**.  
The **New Backup Repository** dialog box appears (see [Figure 37 on the next page](#)).

**Figure 37:** New Backup Repository - Name

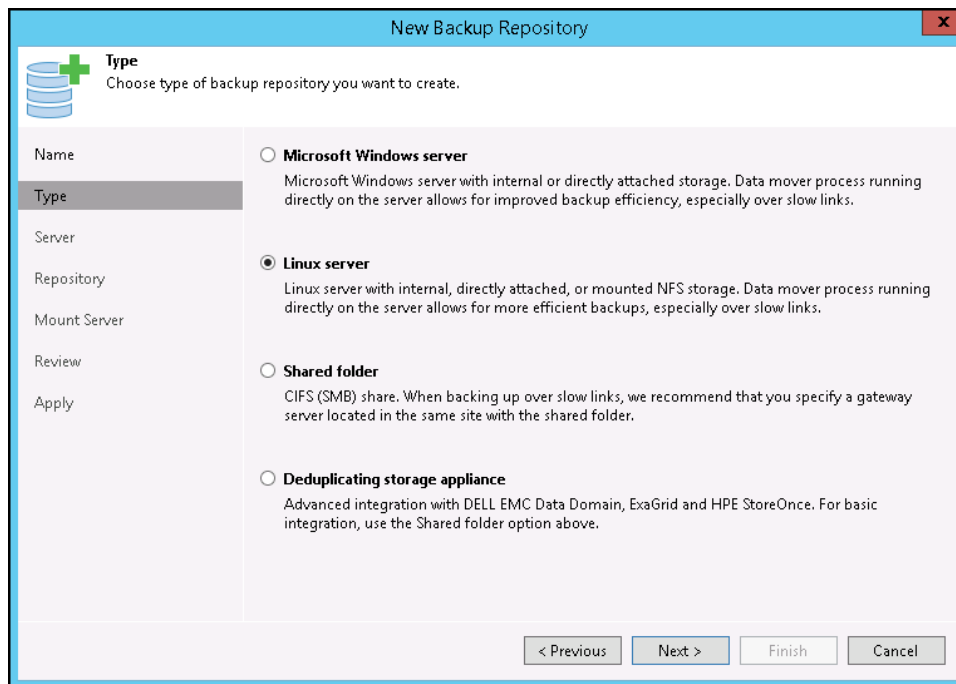


14. Enter a **Name** for the new DXi backup repository.

15. Click **Next**.

The **New Backup Repository - Type** screen appears (see [Figure 38 on the next page](#)).



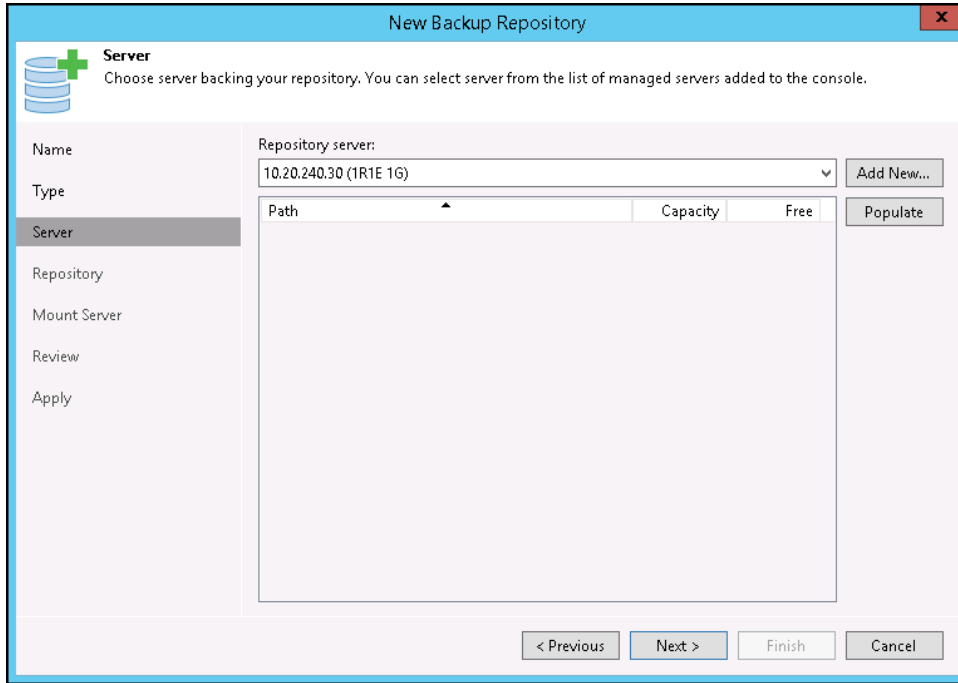
**Figure 38:** New Backup Repository - Type

16. Select **Linux Server** from the backup repository type options

17. Click **Next**.

The **New Backup Repository - Server** screen appears (see [Figure 39 on the next page](#)).

**Figure 39:** New Backup Repository - Server



18. Select the **Repository server** created in steps 1 - 12 above.

19. Click **Next**.

The **New Backup Repository - Repository** screen appears (see [Figure 40 on the next page](#)).

**Figure 40:** New Backup Repository - Repository

**Repository**  
Type in path to the folder where backup files should be stored, and set repository load control options.

Name  
Type  
Server  
**Repository**  
Mount Server  
Review  
Apply

**Location**  
Path to folder:  **Browse...**

**Capacity**  
Capacity: ... **Populate**  
Free space: ...

**Load control**  
Running too many concurrent tasks against the same repository may reduce overall performance, and cause I/O operations to timeout. Control storage device saturation with the following settings:  
 Limit maximum concurrent tasks to: 4  
 Limit read and write data rates to:  MB/s

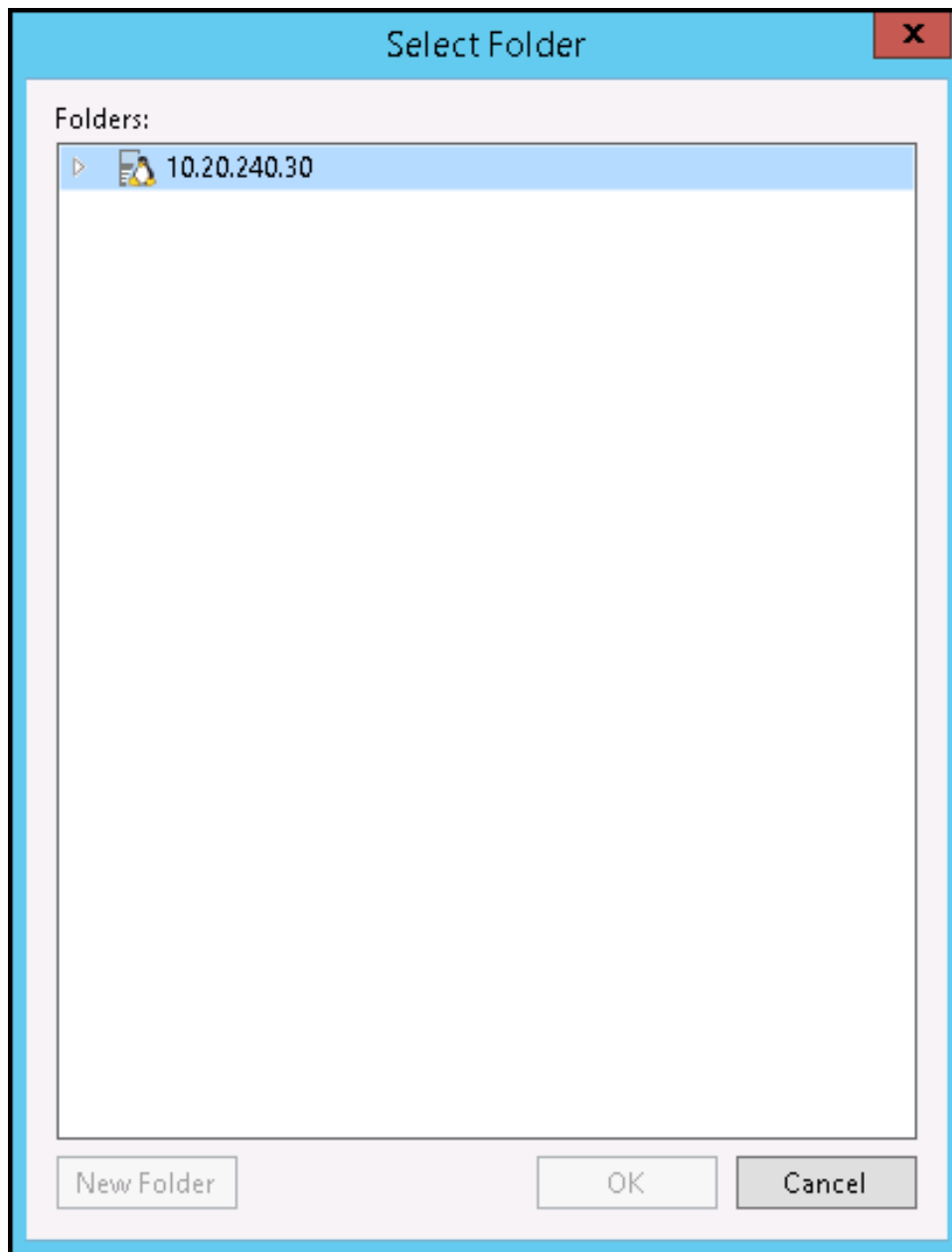
Click *Advanced* to customize repository settings **Advanced...**

< Previous   Next >   Finish   Cancel

20. Click **Browse**.

The **Select Folder** dialog box appears (see [Figure 41 on the next page](#)).

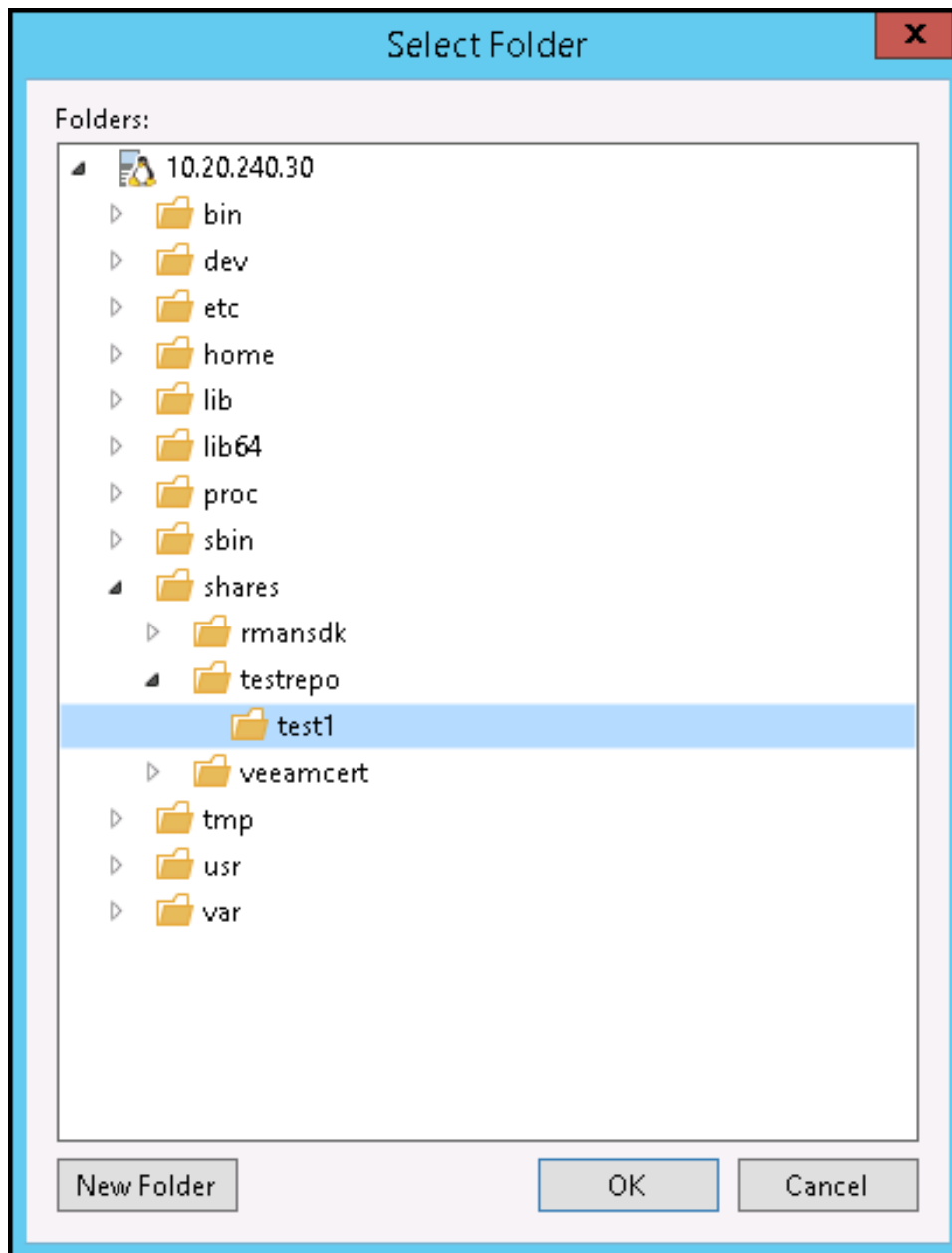
**Figure 41:** Select Folder



21. Navigate to /shares/<share created in DXi> (see [Figure 42 on the next page](#)).

#### **Additional Information**

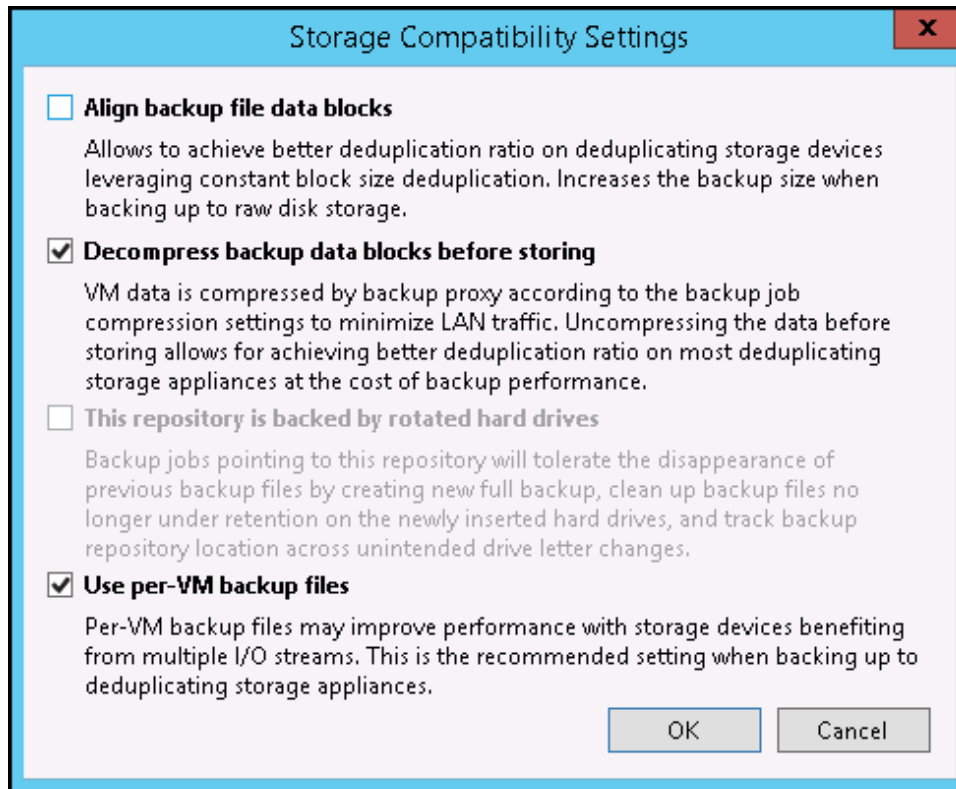
- The NAS share must be created on the DXi system (see [Create a NAS Share on page 30](#)).
- The NAS share must be located in the /shares directory to deduplicate properly.

**Figure 42:** Select NAS Share

22. Click **OK** to close the **Select Folder** dialog box.

23. Click **Advanced**.

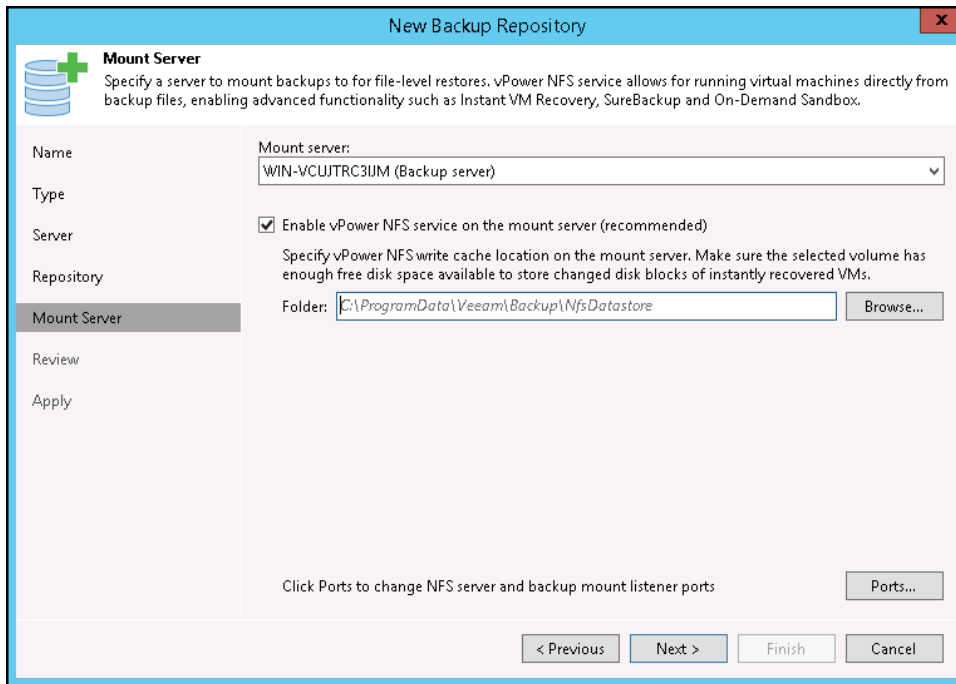
The **Storage Compatibility Settings** dialog box appears (see [Figure 43 on the next page](#)).

**Figure 43:** Storage Compatibility Settings

24. Select the **Decompress backup data blocks before storing** check box.
25. Select the **Use per-VM backup files** check box.
26. Click **OK** to close the **Storage Compatibility Settings** dialog box.
27. In the **New Backup Repository - Repository** screen, set the **Limit maximum concurrent task** (see [Figure 40 on page 43](#)). Quantum recommends that you do not exceed 25 concurrent streams.
28. Click **Next**.

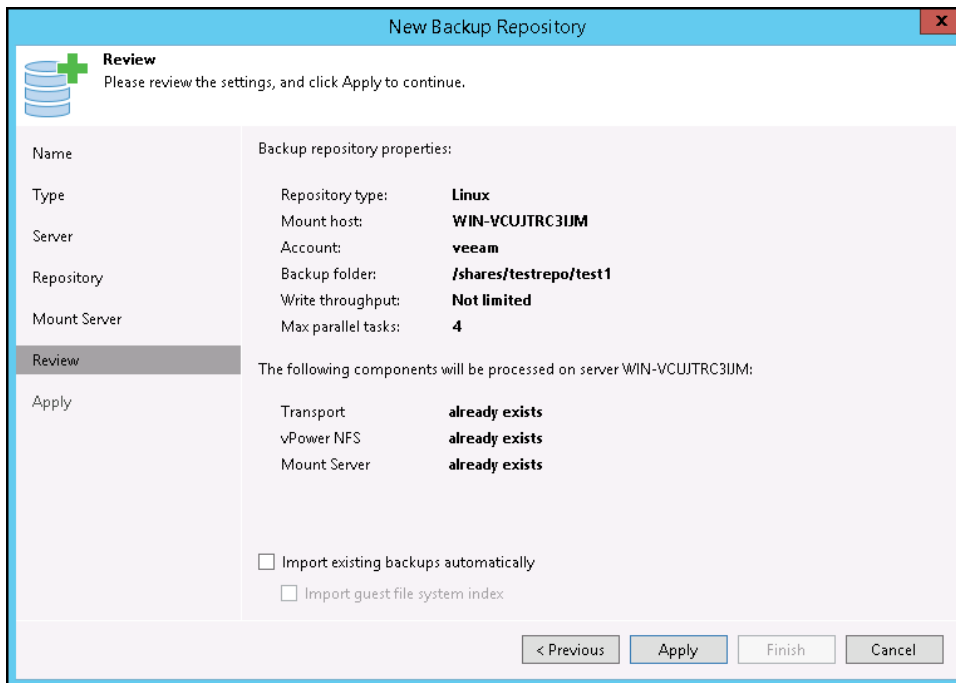
The **New Backup Repository - Mount Server** screen appears (see [Figure 44 on the next page](#)).

**Figure 44: New Backup Repository - Mount Server**



29. Do not change the **Mount Server** default settings. Click **Next**.  
The **New Backup Repository - Review** screen appears (see [Figure 44 above](#)).

**Figure 45: New Backup Repository - Review**



30. Review the backup repository changes.
31. Click **Apply** to save and apply the changes. The repository is now ready for backup and restoration operations.

---

## Manage Veeam

Use the following commands to manage Veeam agent integration.

**i Note:** The CLI Admin (**cliadmin**) account must be enabled on the DXi. If you do not have the password for this account, contact the DXi administrator.

### Query Veeam Settings

This command returns the current Veeam agent settings.

#### Command

```
syscli --get veeam
```

#### Example output

Output data:

AE state = aeDaeRunning

Enabled = disabled

Password is = locked

### Enable Veeam

This command enables or disables the Veeam agent.

#### Command

```
syscli --set veeam [--enable on|off] [--passwd lock|unlock] [--password  
<password>] [--sure]
```

#### Command Attributes

Review the following attribute descriptions.



---

|                                    |   |
|------------------------------------|---|
| <b>--set veeam</b>                 | Enable access for the Veeam agent.<br><br>Either the password or the key must be entered. The system will reboot if the enable state is changed. A password change does not require a reboot. |
| <b>--enable on off</b>             | If specified, the Veeam agent login will be enabled or disabled. If the state is changed, the system will reboot.   |
| <b>--passwd lock unlock</b>        | Specifies if a password access is allowed.  |
| <b>--password &lt;password&gt;</b> | If the password is not specified, the command will prompt for the password and it will not be echoed.   |
| <b>--sure</b>                      | If specified, this command will execute immediately without asking for confirmation.  |

---