

Quantum[®]

ActiveScale

with ActiveScale OS 6.x software

X100 Support Guide

6-68843-05, Rev. A

Quantum ActiveScale™ X100 Support Guide, 6-68843-05, Rev. A, July 2022, Product of USA.

Quantum Corporation provides this publication “as is” without warranty of any kind, either express or implied, including but not limited to the implied warranties of merchantability or fitness for a particular purpose. Quantum Corporation may revise this publication from time to time without notice.

COPYRIGHT STATEMENT

© 2022 Quantum Corporation. All rights reserved. Your right to copy this manual is limited by copyright law. Making copies or adaptations without prior written authorization of Quantum Corporation is prohibited by law and constitutes a punishable violation of the law. ActiveScale, DXi, DXi Accent, FlexSync, FlexTier, iLayer, Lattus, Quantum, The Quantum Logo, QXS, Scalar, StorNext, SuperLoader, Vision, and Xcellis are either registered trademarks or trademarks of Quantum Corporation and its affiliates in the United States and/or other countries. All other trademarks are the property of their respective owners. Quantum specifications are subject to change.

TRADEMARK STATEMENT

Quantum is/are a registered trademark of Quantum Corporation and ActiveScale is a trademark of Quantum Corporation and its affiliates in the United States and/or other countries. Amazon S3, Amazon Simple Storage Services, and Amazon AWS S3 are trademarks of Amazon.com, Inc. or its affiliates in the United States and/or other countries. BitDynamics® and BitSpread® are trademarks of Western Digital Corporation. Other trademarks are the property of their respective owners. References in this publication to Quantum-branded products, programs, or services do not imply that they will be made available in all countries. Product specifications provided are sample specifications and do not constitute a warranty. Actual specifications for unique part numbers may vary. Please visit the Support section of our website <https://quantum.com/support> for additional information on product specifications.

Contents

1 ActiveScale X100 product overview	10
1.5 Available kits and upgrades	16
1.5.1 Scale up kits.....	16
1.5.2 Scale out kits.....	16
1.5.3 Rack seal kits.....	16
1.5.4 System Expansion Node kits	16
2 Component overview.....	17
2.1.3 Management Interconnect specifications.....	20
2.2.2 Replaceable parts for System Interconnects	24
2.2.3 System Interconnect specifications.....	24
2.3.3 System Node specifications.....	27
2.4 Storage Node	28
2.4.3 Storage Node specifications	30
2.5 Pull-out tabs	31
2.6 Storage Enclosure Basic.....	31
2.7.3 PDU specifications	39
2.7.4 Power cords	40
3 Parts replacement steps.....	41
3.1.2 Programming PDUs.....	44
3.2.1 Replacing Management Interconnects (rackless system)	50
3.2.2 Replacing Management Interconnects (racked system).....	51
3.3 System Interconnect part replacement instructions	54
3.3.1 Replacing System Interconnect fans.....	54
3.3.2 Replacing System Interconnect PSUs	55
3.3.3 Replacing QSFP+ 40G transceivers	56
3.3.4 Replacing System Interconnects.....	57
3.4 System Node part replacement instructions.....	61
3.4.1 Replacing System Node drives (SSD and HDD)	61
3.4.2 Replacing System Node PSUs.....	63
3.4.3 Replacing SFP+ transceivers	64
3.4.4 Replacing System Nodes.....	66
3.5 Storage Node part replacement instructions	69
3.5.1 Replacing 2.5 inch drives	70
3.5.2 Replacing Storage Node PSUs	72
3.5.4 Replacing Storage Nodes.....	74
3.6 Storage Enclosure Basic part replacement instructions.....	77
3.6.1 Replacing Storage Enclosure Basic I/O modules	77
3.6.2 Replacing Storage Enclosure Basic sleds or sled blanks	82
3.6.3 Replacing Storage Enclosure Basic fans.....	86
3.6.4 Replacing Storage Enclosure Basic PSUs	87
3.6.6 Replacing a Storage Enclosure Basic chassis	93
3.7 Rack part replacement instructions	99
3.7.1 Replacing the Management Interconnect mounting kit (racked systems)	99
3.7.2 Replacing the 1U mounting kit for System and Storage Nodes.....	100
3.7.3 Replacing the System Interconnect 1U mounting kit (racked systems).....	103
3.7.4 Replacing System Interconnect 3U mounting kit (rackless systems)	104
3.7.5 Replacing the Storage Enclosure Basic rail kit.....	108

3.7.6	Front and rear rack doors	112
3.7.7	Rack tip plates	114
4	System cabling	117
4.5	Single-phase PDU power sequencing	129
5.2	Provisioning the newly added sleds on a single site system	141
6	Installing scale out kits	151
6.2.1	Additional Parts Required for Multi-Site Configuration	152
6.3	Connecting the Cables Between the Systems.....	153
6.4	Cabling Three Systems	154
6.5	Opening Interconnect Ports.....	155
6.6	Additional steps for multi-site configurations.....	157
6.6.1	Software steps.....	158
6.6.2	Post-requisites.....	163
7	Installing rack seal kits	164
7.1	Installing the rack seal plate.....	165
8	Installing System Expansion Node kits	168
8.1.2	Multi-site deployment requirements	169
8.1.3	Rack requirements	169
8.1.4	PDU requirements	169
8.3	Installing System Expansion Node kits.....	170
8.4	Connecting the System Expansion Node kit networking cables	174
8.6	Installing the System Expansion Node PDU kit	176
8.7	Programming the System Interconnects.....	186
8.8	Powering on the System Expansion Node	188
8.9	Software steps for adding a System Expansion Node kit.....	188
9	Re-racking a system.....	195
9.2.1	PDU requirements	197
9.3.1	Re-racking order	198
9.3.2	Transferring the system hardware to the new rack	198
9.3.3	Completing re-racking	199
10	Split-racking a system.....	200
10.3	PDU requirements.....	202
10.4.4	Cabling for split-rack single-phase PDU configurations	206
11	Troubleshooting the ActiveScale™ X100.....	207
11.1.2	Troubleshooting an HD MiniSAS cable LED fault	209
11.1.3	Troubleshooting a power supply unit fault LED.....	209
11.1.4	Troubleshooting an I/O module fault LED	209
11.1.5	Troubleshooting a sled fault LED.....	213
11.1.6	Troubleshooting a drive fault LED	219
11.2.1	Troubleshooting tripped breakers on a PDU.....	226
12	System specifications	227
12.3	Management Interconnect specifications	231
12.5	Rack specifications	233
12.7	Storage Enclosure Basic specifications	235
12.9	System Interconnect specifications	236
12.10	System Node specifications	237
13	Recommended torque of machined fasteners	238
	Contacting Quantum.....	239

1 ActiveScale X100 product overview

This guide applies to both rackless and racked ActiveScale X100 systems.

This section provides an overview of the ActiveScale X100 system.

1.1 About the ActiveScale X100

The ActiveScale X100 is a 42U, scalable, object-based data storage system that allows you to easily keep up with data growth and deliver on your business objectives.

The minimum configuration is equipped with one sled column in all six Storage Enclosure Basics and provides either:

- 0.84 PB of data storage capacity using 10 TB HDDs.
- 1.008 PB of data storage capacity using 12 TB HDDs.
- 1.176 PB of data storage capacity using 14 TB HDDs.

Multi-site systems can achieve a maximum storage capacity of either:

- 52.92 PB (raw) using 10 TB HDDs.
- 63.504 PB (raw) using 12 TB HDDs.
- 74.088 PB of data storage capacity using 14 TB HDDs.

Note: 12 TB HDDs require ActiveScale OS 5.3 or later. 14 TB HDDs require ActiveScale OS 5.5 or later.

The Storage Enclosures are connected using two 48 port System Interconnects.

ActiveScale X100 systems are equipped with ActiveScale OS software.

Table 1-1. ActiveScale X100 identification

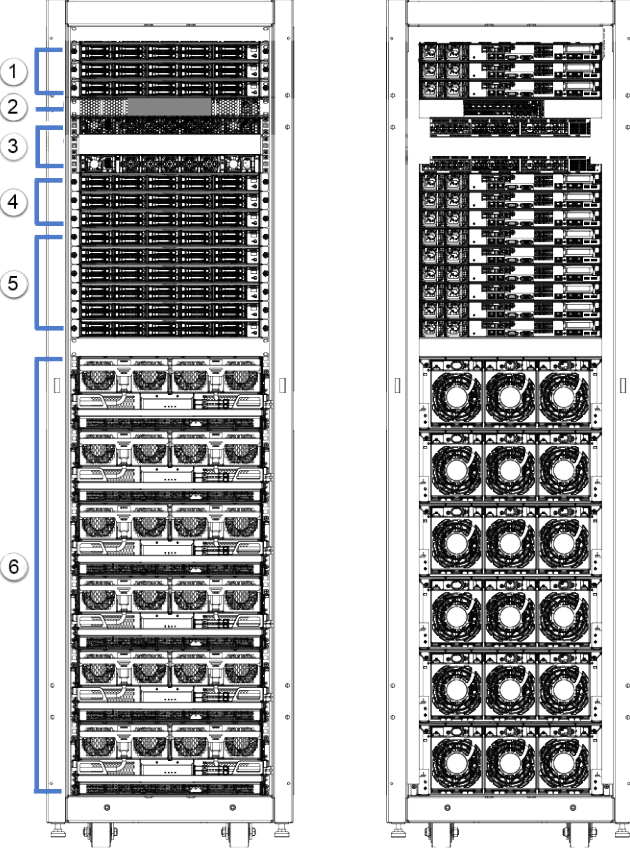
	Number	Component
 <p data-bbox="190 1220 737 1245">On rackless or re-racked systems, component location may vary.</p>	1	(Optional) System Expansion Nodes. System Expansion Nodes are available as part of the System Expansion Node kit. Each kit contains one System Expansion Node.
	2	Management Interconnect
	3	System Interconnects (blanking panels not shown) Note: There is no requirement to leave space between System Interconnects in a racked system.
	4	System Nodes
	5	Storage Nodes
	6	Storage Enclosure Basics
	N/A	PDUs On a standard system, either two or three 3-phase, or four single-phase PDUs are attached at the back of the rack on either side of the cabinet. On a rackless system, PDUs are supplied by the customer and their installation location may vary.

1.2 System specification summary

The following table is a summary of specifications relevant to the ActiveScale X100.

Condition (fully configured)	Non-operating	Operating
Altitude	-984 ft to 39,371 ft (-300 m to 12,000 m)	-984 ft to 10,000 ft (-300 m to 3048 m)
Packed system dimensions	<ul style="list-style-type: none"> • Width—41.4 in (1052 mm) • Depth—61.41 in (1560 mm) • Height—88.3 in (2243 mm) 	

Condition (fully configured)	Non-operating	Operating
Power requirements	N/A	Base configuration typical/max: <ul style="list-style-type: none"> • 2.5/3.3 kW Base +1 configuration typical/max: <ul style="list-style-type: none"> • 3.15/3.98 kW Base +2 configuration typical/max: <ul style="list-style-type: none"> • 3.8/4.66 kW Base +3 configuration typical/max: <ul style="list-style-type: none"> • 4.45/5.34 kW Base +4 configuration typical/max: <ul style="list-style-type: none"> • 5.1/6.02 kW Base +5 configuration typical/max: <ul style="list-style-type: none"> • 5.75/6.7 kW Full (Base +6) configuration typical/max: <ul style="list-style-type: none"> • 6.4/7.4 kW System Expansion Node kit:¹ <ul style="list-style-type: none"> • .195 to 0.23 kW
Rack units (U)	42U ²	
Relative humidity	10% to 95% non-condensing	8% to 90% non-condensing
System dimensions	<ul style="list-style-type: none"> • Width—23.6 in (600 mm) • Depth—52.6 in (1338 mm) • Height—81.1 in (2060 mm) 	
System dimensions (without doors)	<ul style="list-style-type: none"> • Width—23.6 in (600 mm) • Depth—47.2 in (1200 mm) • Height—81.1 in (2060 mm) 	
Temperature	40°F to 158°F (-40°C to 70°C)	50°F to 95°F (10°C to 35°C)
Temperature de-rating	33.8°F per 984.2 ft above 9842.5 ft (1°C per 300 m above 3000 m)	33.8°F per 984.2 ft above 3116.8 ft (1°C per 300 m above 950 m)
Temperature gradient	86°F (30°C)/hour	68°F (20°C)/hour

Condition (fully configured)	Non-operating	Operating
Thermal output	N/A	<p>Base configuration (one column of populated sleds):</p> <ul style="list-style-type: none"> • 8.53/11.26 KBTU/h <p>Base +1 configuration (two column of populated sleds):</p> <ul style="list-style-type: none"> • 10.75/13.59 KBTU/h <p>Base +2 configuration (three column of populated sleds):</p> <ul style="list-style-type: none"> • 12.96/15.92 KBTU/h <p>Base +3 configuration (four column of populated sleds):</p> <ul style="list-style-type: none"> • 15.17/18.25 KBTU/h <p>Base +4 configuration (five column of populated sleds):</p> <ul style="list-style-type: none"> • 17.38/20.58 KBTU/h <p>Base +5 configuration (six column of populated sleds):</p> <ul style="list-style-type: none"> • 19.59/22.91 KBTU/h <p>Full configuration (base +6, seven columns of populated sleds):</p> <ul style="list-style-type: none"> • 21.83/ 25.25 KBTU/h <p>System Expansion Node kit:¹</p> <ul style="list-style-type: none"> • 0.665 to 0.785 KBTU/hour
Weight	<ul style="list-style-type: none"> • Minimum system weight³—1572 lbs (713 kg) • Full system weight—2227 lbs (1010 kg) • Delivery weight (system and packaging)—2457 lbs (1114 kg) 	

1. Values are for one additional node. System Expansion Node kits can contain up to three additional nodes.

2. Rackless system height can vary based on the installation. A rackless configuration uses 36U of equipment.

3. The minimum system weight does not include the rack and PDUs

1.3 Airflow requirements

Ensure that both the front and rear of the ActiveScale X100 stay clear of any materials that may block or disrupt the airflow in any way. Disrupting the airflow can cause the system to overheat, which may affect performance or cause damage to the system.

The following rack airflow principles should be considered for best results:

- Controlled air conditioners that are functional and can sufficiently maintain specified system operating temperatures should be located in the facility where the system will be installed.
- The airflow in and out of the equipment must not be restricted.

Table 1-2. Airflow requirements

Condition (fully configured)	Non-operating	Operating
Altitude	-984 ft to 39,371 ft (-300 m to 12,000 m)	-984 ft to 10,000 ft (-300 m to 3048 m)
Relative humidity	10% to 95% non-condensing	8% to 90% non-condensing
Temperature	40°F to 158°F (-40°C to 70°C)	50°F to 95°F (10°C to 35°C)
Temperature de-rating	33.8°F per 984.2 ft above 9842.5 ft (1°C per 300 m above 3000 m)	33.8°F per 984.2 ft above 3116.8 ft (1°C per 300 m above 950 m)
Temperature gradient	86°F (30°C)/hour	68°F (20°C)/hour
Thermal output	N/A	Partial configuration (one column populated sleds): <ul style="list-style-type: none"> • 8.53/11.26 KBTU/h Full configuration (seven columns of populated sleds): <ul style="list-style-type: none"> • 21.83/ 25.25 KBTU/h • 0.665 at 0.785 KBTU/hour

1.4 Servicing space requirements

Space at the front and the rear of the system is required to service system components. The front space requirement is based on the length of the longest system component, plus the space necessary to fit a person servicing the system. The rear space requirements is based on space a technician would need to service all of the parts at the rear of the unit.

Table 1-3. Space requirement specifications

Specification	Value
Minimum front of rack space	48 in (1220 mm)
Minimum rear of rack space	22 in (560 mm)

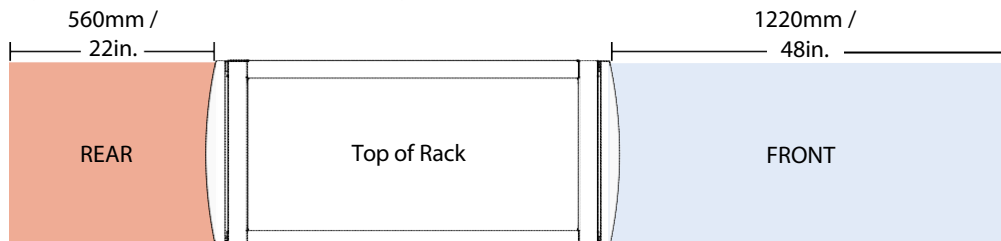
Figure 1-1. Minimum servicing space required

1.5 Available kits and upgrades

This section describes the upgrades and supplemental kits that are available for the ActiveScale X100.

1.5.1 Scale up kits

Each scale up kit contains additional sleds that increases data storage capacity by either:

- 0.84 PB using 10 TB HDDs.
- 1 PB using 12 TB HDDs.
- 1.18 PB using 14 TB HDD's.

For more information, refer to [Installing scale up kits](#) on page 139.

1.5.2 Scale out kits

Storage capacity can be even further increased by connecting a new ActiveScale X100 to an existing system.

For more information, refer to [Installing scale out kits](#) on page 152.

1.5.3 Rack seal kits

You can use the rack seal kit to seal racks with third-party, liquid-cooled doors.

For more information, refer to [Installing rack seal kits](#) on page 165.

1.5.4 System Expansion Node kits

System Expansion Node kits contain one additional System Node for your ActiveScale system. Additional System Nodes allow you to increase system performance with your existing storage capacity. Up to three system expansion kits (three additional System Nodes) can be added to a base ActiveScale system.

For more information, refer to [Installing System Expansion Node kits](#) on page 168.

2 Component overview

This section provides an overview of each ActiveScale X100 component.

2.1 Management Interconnect

The Management Interconnect is used for IPMI control and monitoring of the System Nodes, Storage Nodes, and PDU components. It is connected to System Interconnect 1 and the SFP connector.

Note: The Management Interconnect is non-redundant as it is not a critical component.

Figure 2-2. Management Interconnect

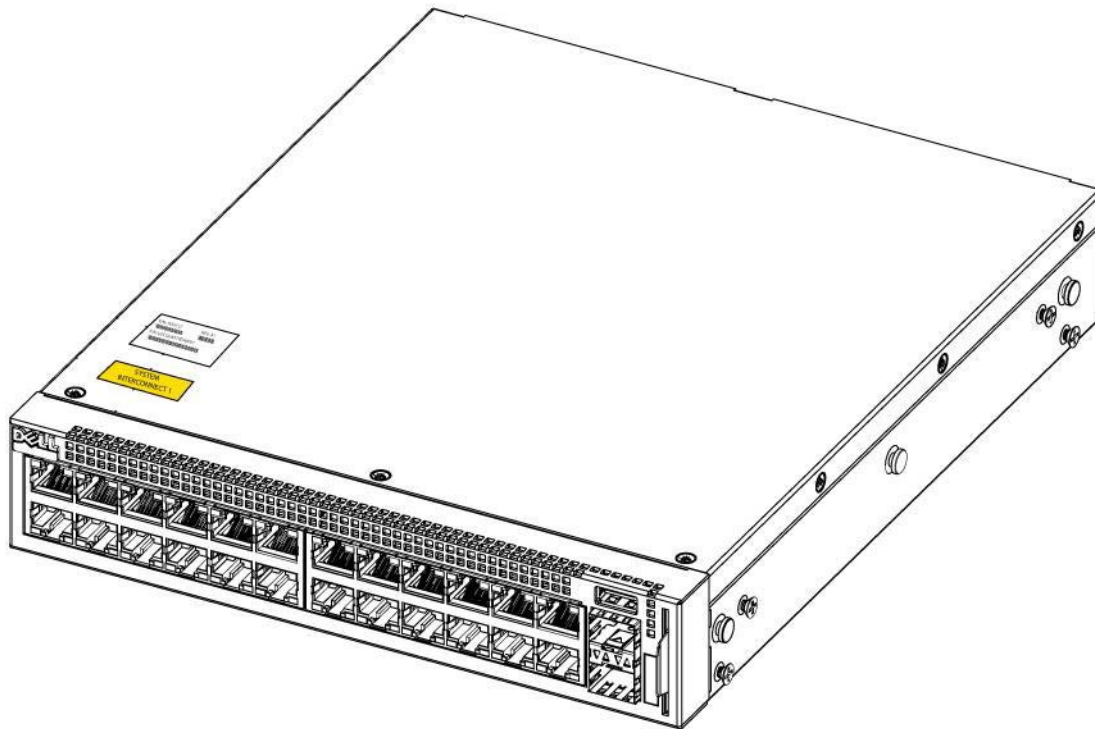

2.1.1 Management Interconnect component identification

The information in this section will help you identify the components in a ActiveScale X100. Management Interconnects.

2.1.1.1 Management Interconnect front and rear view

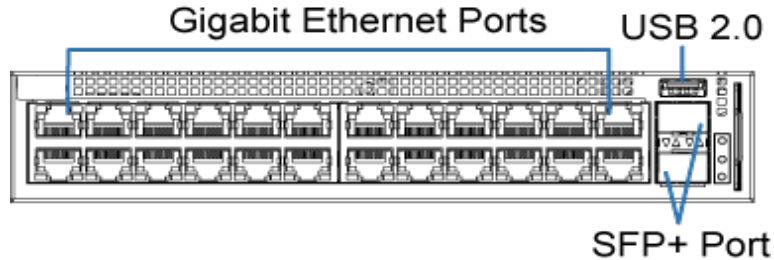

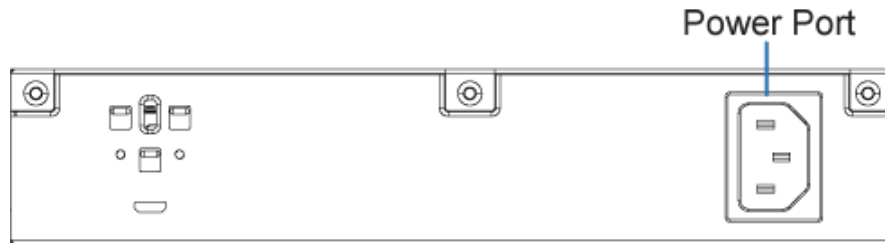

2.1.1.2 Management Interconnect system LEDs

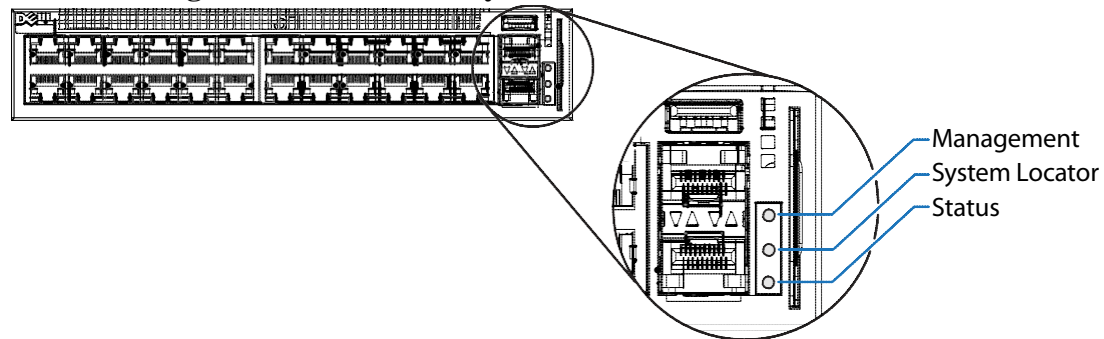

2.1.1.3 Management Interconnect 1G port LEDs

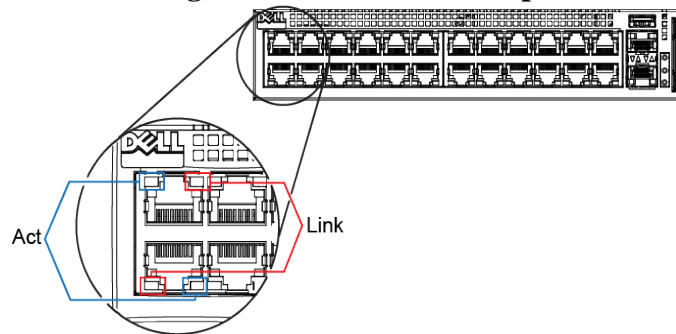

LED name	Description	LED action
Management	Identifies management mode status	<ul style="list-style-type: none"> • Solid green—System in management mode • Off—System is in unmanaged mode
System locator	Locator LED	<ul style="list-style-type: none"> • Blinking blue—Locator is enabled • Off—Locator not enabled
Status	Identifies switch status	<ul style="list-style-type: none"> • Solid green—Normal operation • Blinking green—Booting • Blinking amber—System error has occurred

Table 2-4. Management Interconnect 1G Port LED descriptions

LED name	Description	LED action
Act	Identifies 1G port activity.	<ul style="list-style-type: none"> • Blinking Green—Activity • Off—No Activity

LED name	Description	LED action
Link	Identifies 1G port link status.	<ul style="list-style-type: none"> • Solid Green—Link at 1000Mbps • Solid Amber—Link at 10/100Mbps • Off—No link

2.1.1.4 Management Interconnect SFP+ Port LEDs

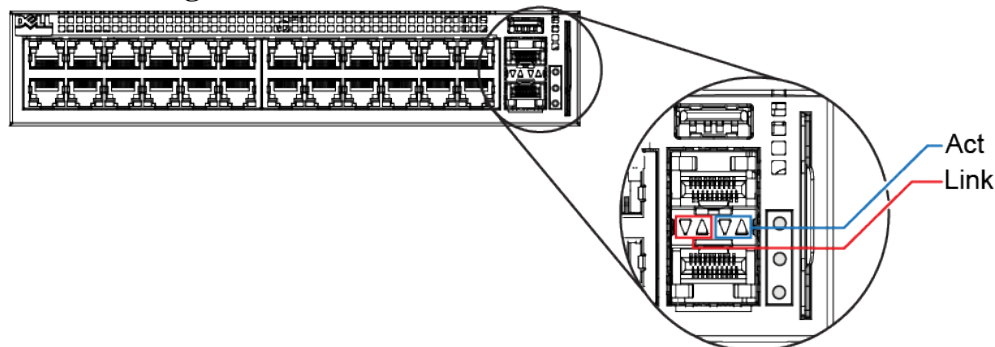

Table 2-5. Management Interconnect SFP+ Port LED descriptions

LED name	Description	LED action
Act	Identifies SFP+ port activity	<ul style="list-style-type: none"> • Blinking Green—Activity • Off—No Activity
Link	Identifies SFP+ port link status.	<ul style="list-style-type: none"> • Solid Green—Link at 10Gbps • Solid Amber—Link at 1Gbps • Off—No link

2.1.2 Replaceable parts for Management Interconnects

The following table lists all of the replaceable components for a Management Interconnect.

Replaceable part	Replacement by Quantum Corporation technician recommended?	Hot swappable?	Part number
Complete Management Interconnect	No	No	1EX0252
Management Interconnect rack ¹ adapter.	No	No	N/A ²
Switch tray	No	No	1EX0087

1. Only applies to rackless ActiveScale X100 configurations. Racked configurations use the switch tray.

2. If the rack adapter requires replacement, contact Quantum Corporation support.

2.1.3 Management Interconnect specifications

The following table lists the system specifications for an individual Management Interconnect.

Table 2-6. Management Interconnect Specifications

Condition	Specification
Dimensions	<ul style="list-style-type: none"> • Width—8.23 in (209 mm) • Depth—9.84 in (250 mm) • Height—1.62 in (41.25 mm)
Hot swappable?	No
Operating relative humidity	10% to 90% non-condensing
Operating temperature	32°F to 122°F (0°C to 50°C)
Quantity (per system)	1
Rack units (U)	1U
Weight	4.14 lbs (1.88 kg)

2.2 System Interconnect

The ActiveScale System Interconnect is a Celestica D2020 switch with 48 10Gigabit SFP+ ports and 4 40 Gigabit QSFP+ ports. The SFP+ ports are used for communication between System Nodes and Storage Nodes. The QSFP+ ports are used for scale outs.

ActiveScale systems contain two System Interconnects that connect to the System and Storage Nodes for maximum bidirectional throughput.

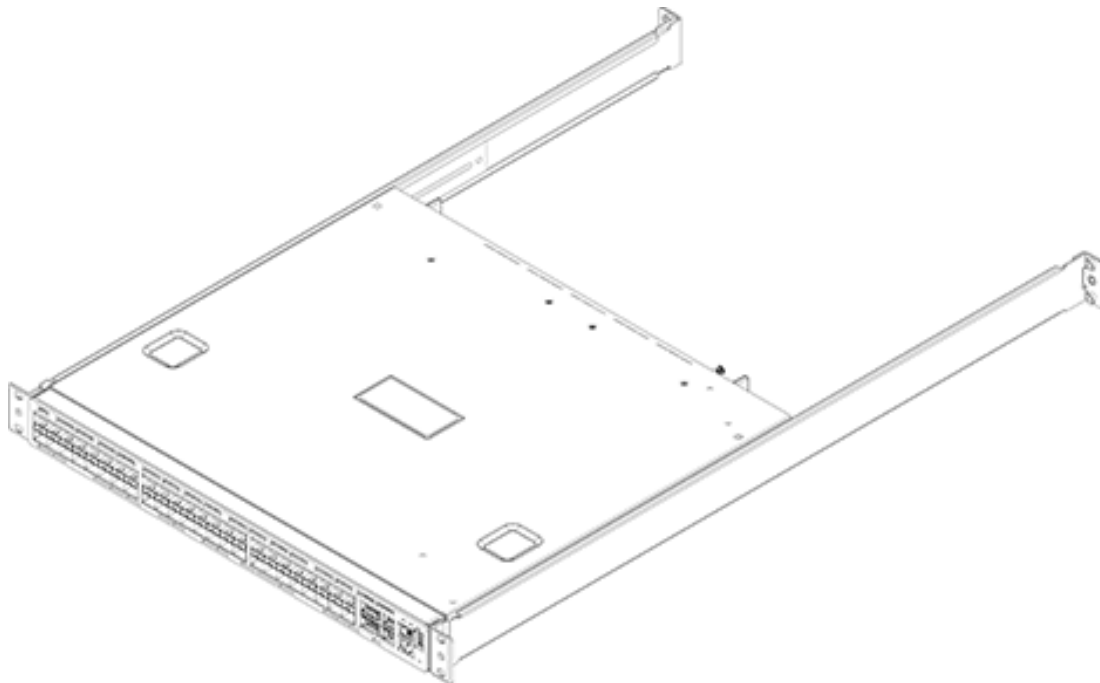
Figure 2-3. System Interconnect

2.2.1 System Interconnect component identification

The information in this section will help you identify the components in ActiveScale System Interconnects.

2.2.1.1 System Interconnect front and rear view

Figure 2-4. System Interconnect front view

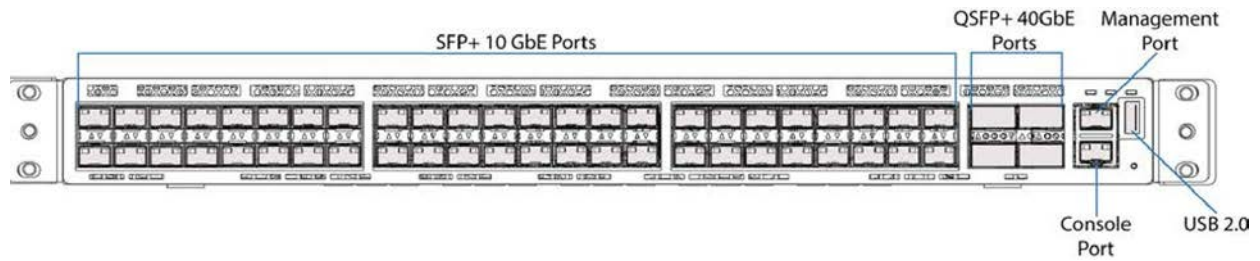
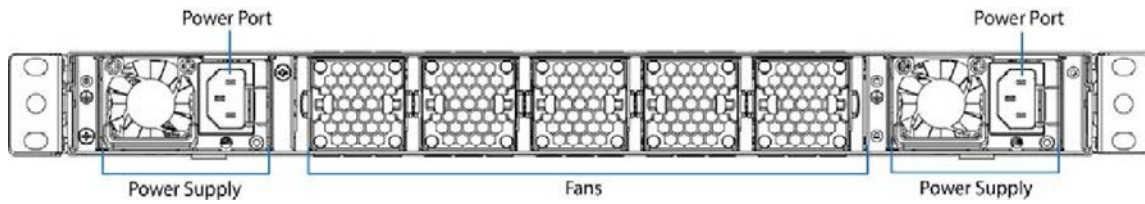

Figure 2-5. System Interconnect rear view



2.2.1.2 QSFP+ports

Figure 2-6. QSFP+ ports



2.2.1.3 System Interconnect LEDs

Figure 2-7. System Interconnect LEDs

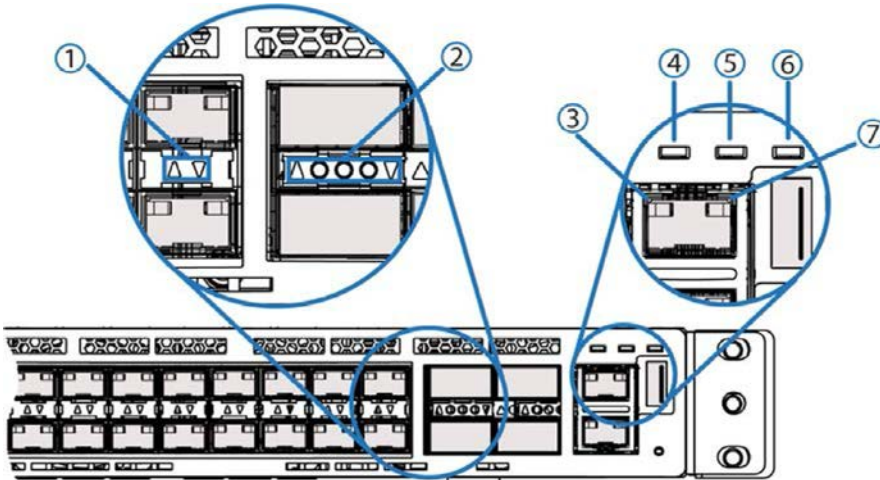

Number	LED name	Description	LED action
1	Link	Identifies data throughput on the port.	<ul style="list-style-type: none"> • Blinking green—Maximum data throughput (10Gbps) is occurring. • Blinking amber—Minimum data throughput (10/100Mbps) is occurring. • Off—No throughput is occurring.
2	Link	Identifies data throughput on the port.	<ul style="list-style-type: none"> • Blinking green—Maximum data throughput (40Gbps) is occurring. • Blinking amber—Minimum data throughput is occurring. • Off—No throughput is occurring.
3	Act	Identifies port activity.	<ul style="list-style-type: none"> • Blinking green—Activity is occurring on this port. • Off—No activity is occurring on this port.
4	P-L (PSU Left)	Identifies left PSU status.	<ul style="list-style-type: none"> • Solid—PSU is powered on and functioning properly. • Off—PSU is off or not functioning properly.
5	P-R (PSU Right)	Identifies right PSU status.	<ul style="list-style-type: none"> • Solid—PSU is powered on and functioning properly. • Off—PSU is off or not functioning properly.
6	STAT	Identifies System Interconnect status.	<ul style="list-style-type: none"> • Blinking—System Interconnect is powered on and functioning properly. • Off—System Interconnect is off or not functioning properly.
7	Link	Identifies port data throughput.	<ul style="list-style-type: none"> • Blinking green—Maximum data throughput (1000Mbps) is occurring. • Blinking amber—Minimum data throughput (10/100Mbps) is occurring. • Off—No throughput is occurring.

2.2.2 Replaceable parts for System Interconnects

The following table lists all of the replaceable components for a System Interconnect.

Replaceable part	Hot swappable?	Part number
Complete System Interconnect ¹	Yes	1EX0255
Fan module	Yes	1EX0022
PSU module, 460W	Yes	1EX0024
QSFP+ 40G short-range transceiver	Yes	1EX0268
SFP+ 10G long-range transceiver ²	Yes	1EX0261
SFP+ 10G short-range transceiver	Yes	1EX0237

1. Replacement rails are not included. Retain the rack rails from the faulty System Interconnect.

2. This component is not standard equipment. Only order if you cannot install a scale out kit using the maximum cable lengths available using a standard SR transceiver.

2.2.3 System Interconnect specifications

The following table lists the system specifications for an individual System Interconnect.

Condition	Specification
Dimensions	<ul style="list-style-type: none"> • Width—17.3 in (438 mm) • Depth—17 in (431 mm) • Height—1.73 in (44 mm)
Hot swappable?	Yes
Operating relative humidity	20% to 85% non-condensing
Operating temperature	41° to 104°F (5°C to 40°C)
Quantity (per system)	Two
Rack Units (U)	1U
Weight (individual)	20 lbs (9 kg)
Weight (total for all System Interconnects)	40 lbs (18 kg)

2.3 System Node

System Nodes are the front end of an ActiveScale system. They run a subset of the ActiveScale OS that handles the management path and parts of the data path.

The single logical System Node is comprised of System Nodes in multiples of three. The three System Nodes are clustered and the services and databases they run must have a minimum membership present in order to function.

Figure 2-8. System Node



2.3.1 System Node component identification

The information in this section will help you identify the components in a System Node.

Note: Newer versions of the System Node do not have a label above the LED panel.

2.3.1.1 System Node front and rear view

Figure 2-9. System Node front view

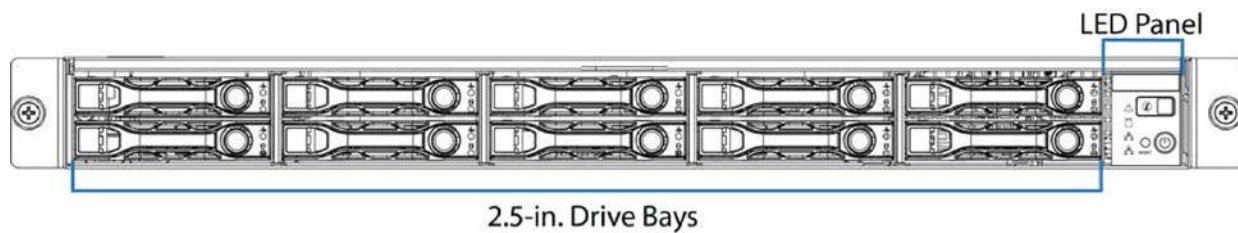
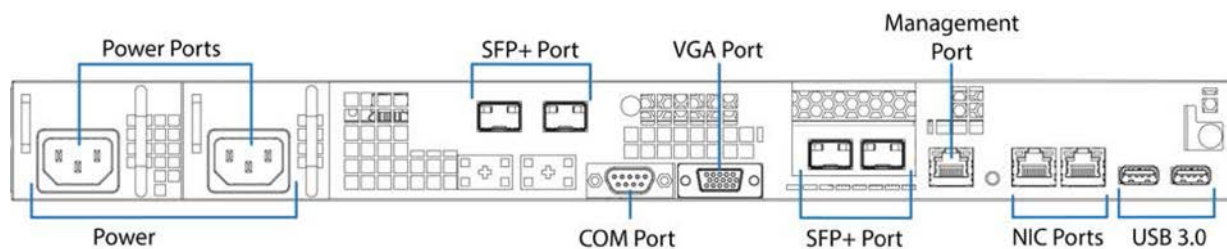
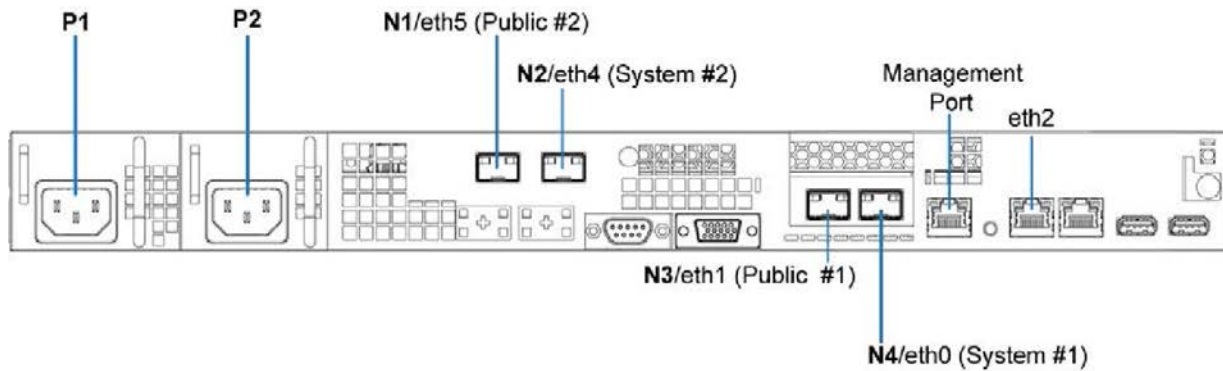

Figure 2-10. System Node rear view



2.3.1.2 Physical port to Ethernet device mapping

Figure 2-11. Physical port to Ethernet device mapping



2.3.1.3 System Node LEDs and buttons

Figure 2-12. System Node LEDs and buttons

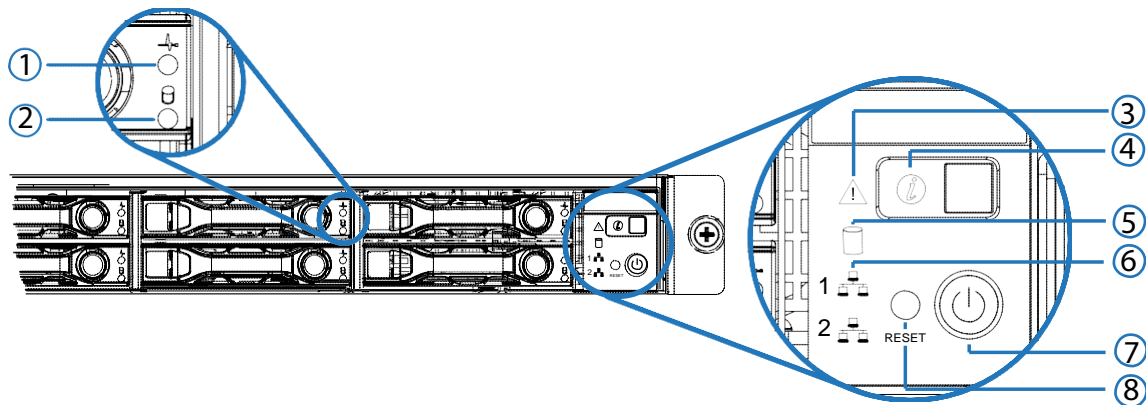

Number	Name	Description	LED action
1	HDD status	Identifies hard disk drive status.	<ul style="list-style-type: none"> • Blinking—Activity • Solid amber— HDD failure detected. • Off—Drive slot is empty.
2	HDD activity	Identifies hard drive activity.	<ul style="list-style-type: none"> • Blinking blue—Hard disk drive access • Off—No access (non-SAS)
3	Fault	Identifies system events.	<ul style="list-style-type: none"> • Solid amber—Indicates the following events: <ul style="list-style-type: none"> – Critical failure—critical fan, voltage, temperature state. – Non-critical failure—non-critical fan, voltage, temperature state, CPU thermal trip, DC off. • Blinking amber—Indicates a change or event has occurred on the System Node. Use the SEL to get more info and to clear it if appropriate. • Off—SEL cleared or last pending warning or error has been de-asserted.

Number	Name	Description	LED action
4	Identification	Locater LED.	<ul style="list-style-type: none"> • Solid blue—Identification feature has been activated. • Blinking—Identification LED has been activated • Off—No identification request
5	HDD activity	Identifies hard disk drive access.	<ul style="list-style-type: none"> • Blinking blue—Hard disk drive access (on-board SATA port only) • Off—No access (non-SAS)
6	LAN1/LAN2	Identifies Link or LAN1/LAN2 access	<ul style="list-style-type: none"> • Solid blue—Link • Blinking blue—LAN access (off when there is traffic)
7	Power button	Powers on/off System Node.	<ul style="list-style-type: none"> • Solid blue—Powered on • Off—Powered off
8	Reset button	Resets the System Node.	N/A

2.3.2 Replaceable parts for System Nodes

The following table lists all of the replaceable components for a System Node.

Replaceable part	Replacement by Quantum Corporation technician recommended?	Hot swappable?	Part number
1 TB HDD with drive carrier	No	Yes ¹	1EX0222
960 GB SSD with drive carrier	No	Yes ¹	1EX0258
PSU module, 400 W	No	Yes	1EX0209
System Node chassis	Yes	No	1EX0207

1. Only hot swappable after decommissioning.

2.3.3 System Node specifications

The following table lists the system specifications for an individual System Node.

Condition	Specification
Dimensions	<ul style="list-style-type: none"> • Width—17.2 in (438 mm) • Depth— 29.2 in (741.6 mm) • Height— 1.73 in (44 mm)
Hot swappable?	No
Operating relative humidity	20% to 85% non-condensing
Operating temperature	41° to 104°F (5°C to 40°C)
Quantity (per system)	Three
Rack Units (U)	1U
Weight (per component)	27 lbs (12.2 kg)
Weight (total for all System Nodes)	81 lbs (36.6 kg)

2.4 Storage Node

The Storage Node used in the ActiveScale X100 manages the metadata for the Storage Enclosure Basic and coding and decoding of objects. The Storage Node also contains two redundant Power Supply Units (PSU) that can be replaced while the server is running.

There are six Storage Nodes in the ActiveScale X100 that connect to the System Interconnects to provide connection to the System Nodes.

Figure 2-13. Storage Node

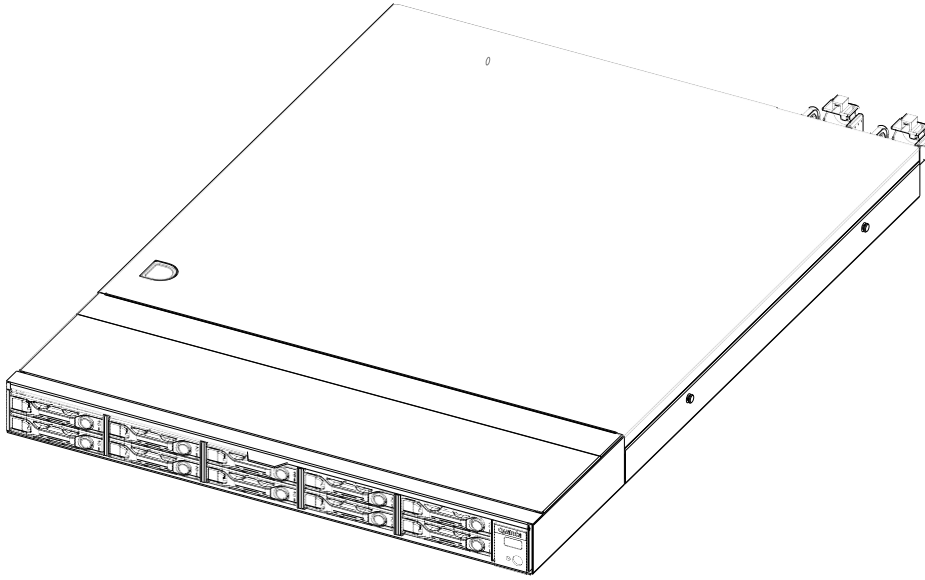

2.4.1 Storage Node component identification

The information in this section will help you identify the components in an ActiveScale Storage Node.

2.4.1.1 Storage Node front and rear view

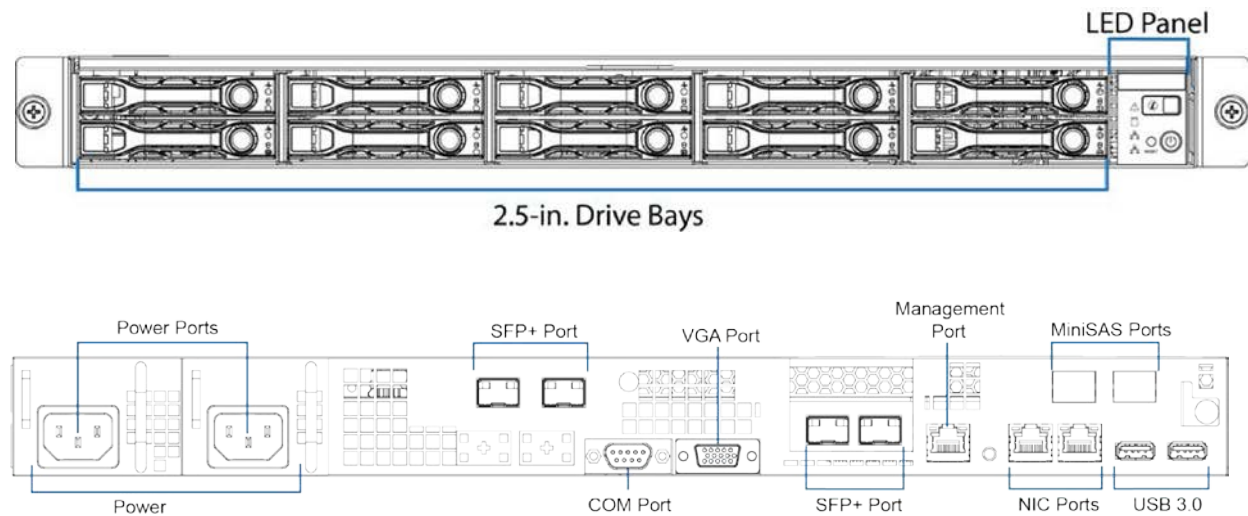

2.4.1.2 Physical port to Ethernet device mapping

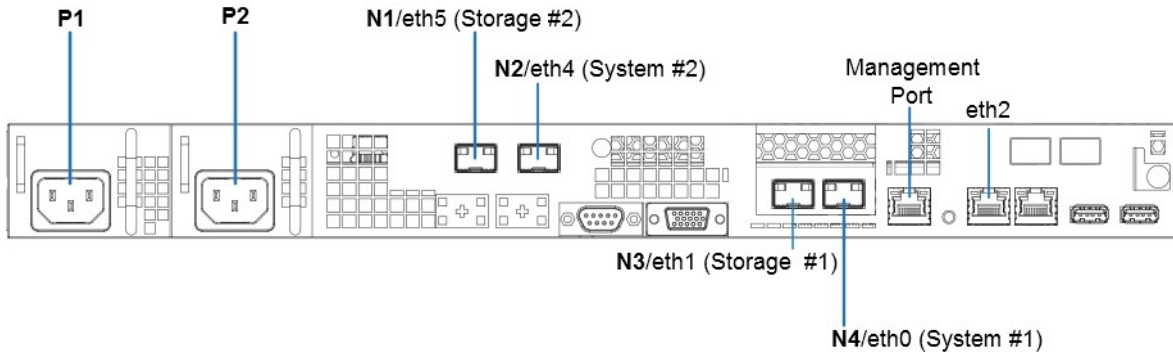

2.4.1.3 SFP+ ports

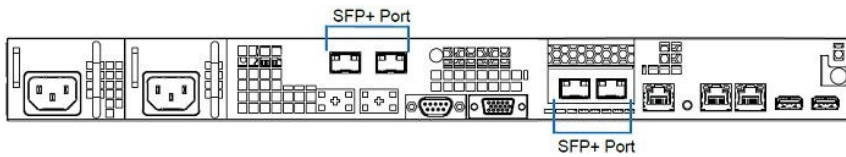

2.4.1.4 Storage Node LED and button identification

This section provides information on how to read and identify the LEDs and buttons on the Storage Node.

Figure 2-14. Storage Node LED and Button Identification

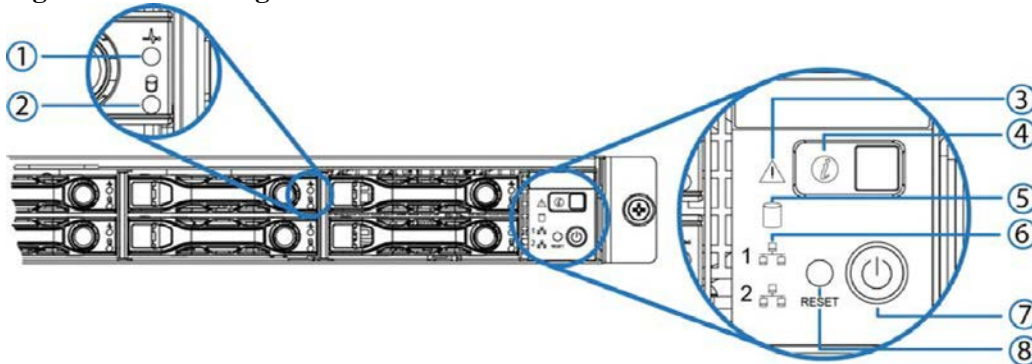

Table 2-7. Storage Node button and LED Descriptions

Callout	LED/Button name	Description	LED action
1	Heartbeat LED	Indicates activity on the drive.	<ul style="list-style-type: none"> • Blinking—Activity
2	HDD Activity	Indicates activity on the hard drive when flashing.	<ul style="list-style-type: none"> • Blinking blue—Hard disk drive access (only on board SATA port) • Off—No access (non-SAS)
2	HDD Activity	Indicates activity on the hard drive when flashing.	<ul style="list-style-type: none"> • Blinking blue—Hard disk drive access (only on board SATA port) • Off—No access (non-SAS)

Callout	LED/Button name	Description	LED action
3	Fault	Indicates critical and non-critical faults.	<ul style="list-style-type: none"> • Solid amber—Critical Failure: critical fan, voltage, temperature state or Non-Critical Failure: non-critical fan, voltage, temperature state, CPU thermal trip, DC off. Also on when the SEL is full. • Off—SEL cleared or last pending warning or error has been de-asserted
4	Identification	Indicates that the component has been identified.	<ul style="list-style-type: none"> • Solid blue—Identification feature has been activated. • Blinking—Identification LED has been activated. • Off—No identification request
6	LAN1/LAN 2	Indicates Link or LAN1/LAN2 access.	<ul style="list-style-type: none"> • Solid blue—Link • Blinking blue—LAN access (off when there is traffic)
7	Power	Indicates that the component is powered on.	<ul style="list-style-type: none"> • Solid blue—Powered on • Off—Powered off

2.4.2 Replaceable parts for Storage Nodes

The following table lists all of the replaceable components for a Storage Node.

Replaceable part	Hot swappable?	Part number
10 TB HDD with carrier	Yes ¹	1EX0170
12 TB HDD with carrier	Yes ¹	1EX0411
14 TB HDD with carrier	Yes	1EX1888
480 GB SSD with carrier	Yes	1EX0221
PSU module, 400 W	Yes	1EX0209
Storage Node chassis	--	1EX0206

1. Only hot swappable after decommissioning.

2.4.3 Storage Node specifications

The following table lists the system specifications for an individual Storage Node.

Table 2-8. Storage Node Specifications

Condition	Specification
Dimensions	<ul style="list-style-type: none">• Width—17.244 (438 mm)• Depth—24 in (609.6 mm)• Height—1.7in (43.2 mm)
Hot swappable?	No
Operating relative humidity	20% to 85% non-condensing
Operating temperature	41° to 104°F (5°C to 40°C)
Quantity (per system)	Six
Rack Units (U)	1U
Weight (per component)	29 lbs (13.1 kg)
Weight (total for all Storage Nodes)	174 lbs (118.38 kg)

2.5 Pull-out tabs

Both System and Storage Nodes have a pull-out tab that lists the node's part number and serial number. The pull-out tab is located in the following locations:

- **System Node** - Top-center of the node.
- **Storage Node** - To the right of the SSD drive.

2.6 Storage Enclosure Basic

The Storage Enclosure Basic is a 4U, high-density storage enclosure. The enclosure is designed to house up to a full configuration of 98 qualified HDDs divided over seven sleds and to maximize the performance of these drives under all operating conditions.

There are six Storage Enclosure Basic units in the ActiveScale X100 that connect to the Storage Nodes to control the storage of objects. Each Storage Enclosure Basic contains two redundant PSUs that can be replaced while the enclosure is running. The enclosure fans are also redundant and can also be replaced while the enclosure is running to allow for little or no down time of the enclosure. If the enclosure is not fully populated, the empty slots are filled with sled blanks to manage the cooling of the enclosure. For partially populated enclosures, each of the six enclosures require the same column to be upgraded at the same time.

Figure 2-15. Storage Enclosure Basic

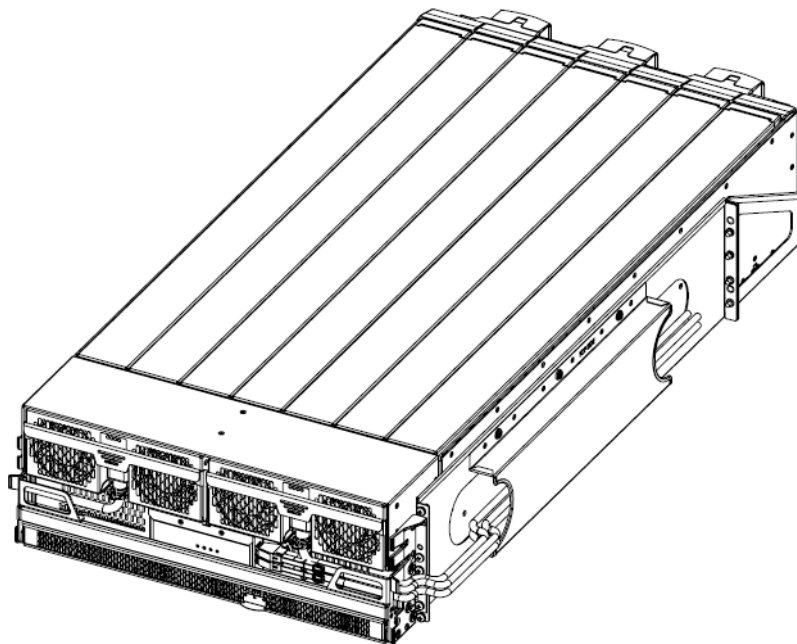

2.6.1 Storage Enclosure Basic component identification

The information in this section will help you identify the components in an ActiveScale Storage Enclosure Basic.

2.6.1.1 Storage Enclosure Basic front and rear view

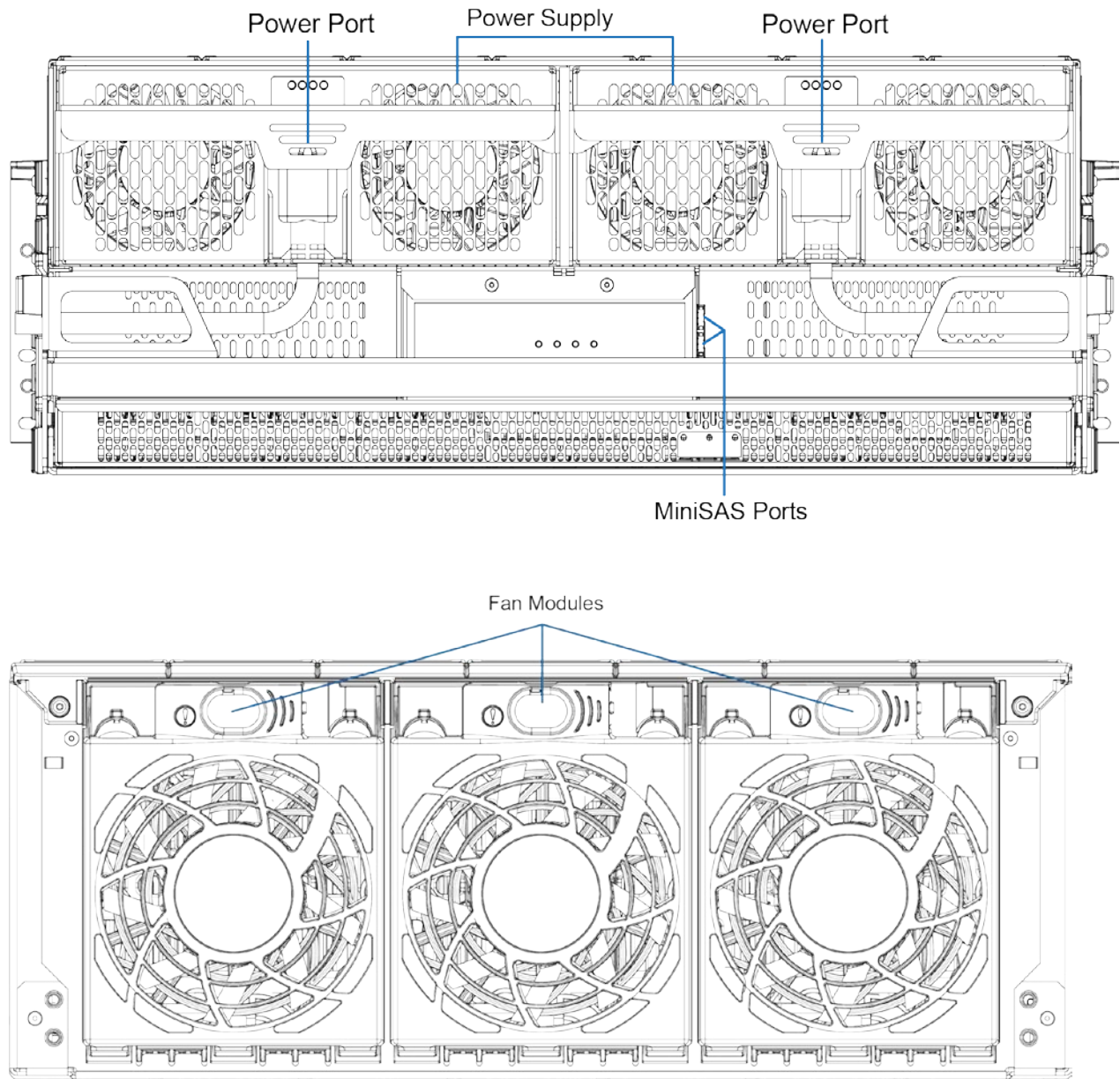

2.6.1.2 Storage Enclosure Basic LEDs

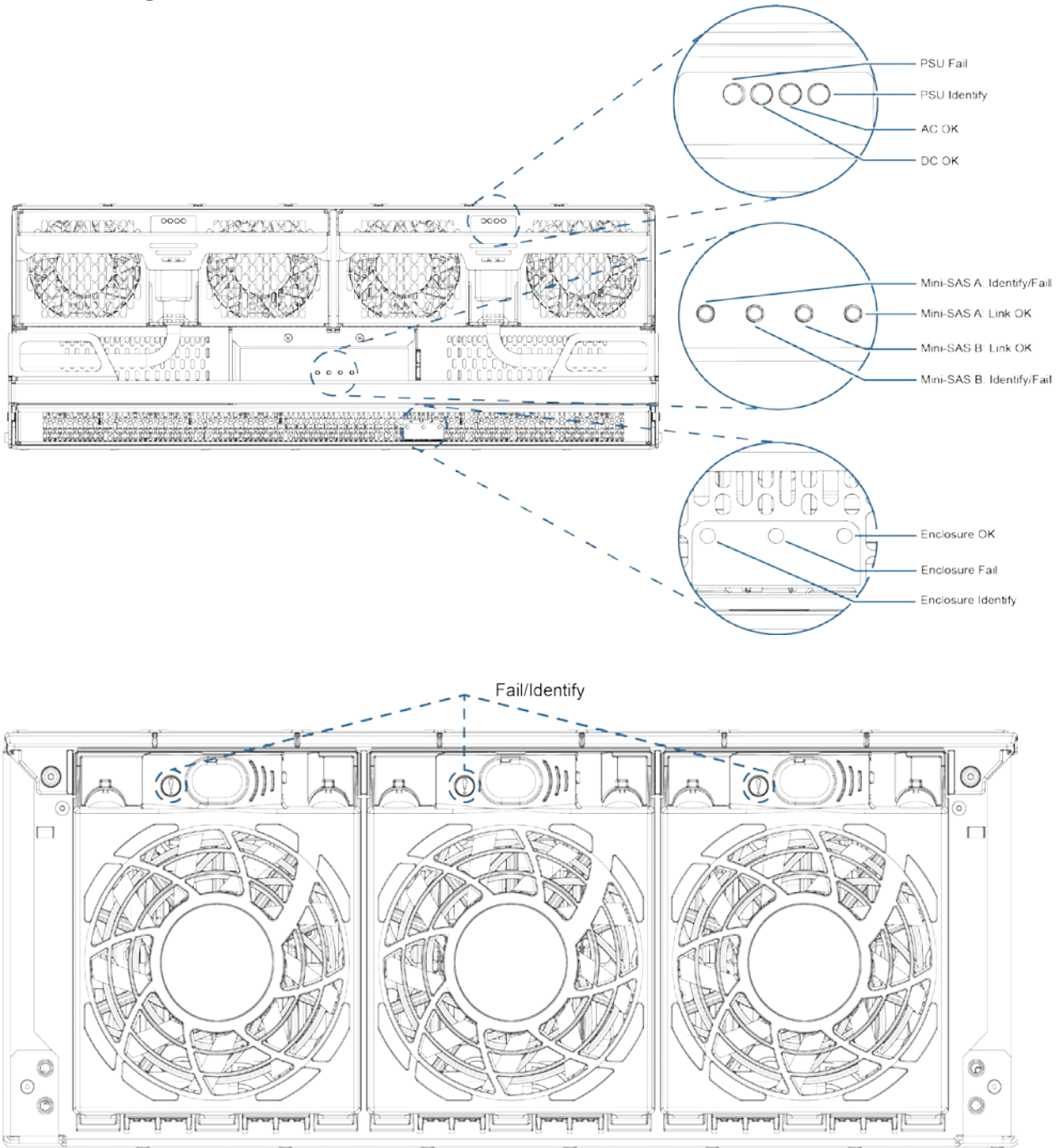

Table 2-9. Storage Enclosure Component Identification

Component	Name	Description	LED action
I/O module	Mini-SAS A: identify/fail	Identifies the failure in Mini-SAS A.	Solid yellow
	Mini-SAS A: link OK	Indicates that the link is within regulation.	Solid green
	Mini-SAS B: link OK	Indicates that the link is within regulation.	Solid green
	Mini-SAS B: identify/fail	Identifies the failure in Mini-SAS B.	Solid yellow
	Enclosure OK	Indicates the Enclosure is within regulation.	Solid green
	Enclosure fail	Indicates a failure in the enclosure.	Solid yellow
	Enclosure identify	Identifies the enclosure.	Solid blue
Power Supply Unit	PSU fail	Identifies failure in the PSUs.	Solid amber
	PSU identify	Identifies the PSUs.	Solid blue
	AC OK	Indicates that AC into the unit is within regulation.	Solid green
	DC OK	Indicates that AC into the unit is within regulation.	Solid green
Rear fan	Fail/identify	Identifies connection and failure of the component	Solid amber

2.6.2 Replaceable parts for Storage Enclosure Basics

The following table lists all of the replaceable components for a Storage Enclosure Basic.

Caution: Never place 12 TB or 14 TB HDDs in a 10 TB HDDs sled.

Replaceable part	Replacement by Western Digital technician recommended?	Hot swappable?	Part number
10 TB HDD with drive carrier	Yes	No	1EX0170
10 TB sled without hard disk drives	Yes	No	1EX0002
12 TB HDD with drive carrier	Yes	No	1EX0411
12+ TB sled without hard disk drives	Yes	No	1EX1175
14 TB HDD with drive carrier	Yes	No	1EX1888
Chassis base assembly 10 TB	Yes	No	1EX0001
Chassis base assembly 12+ TB	Yes	No	1EX1463

Replaceable part	Replacement by Western Digital technician recommended?	Hot swappable?	Part number
I/O module	Yes	No	1EX0003
PSU module, 1200 W	No	Yes	1EX0006
Rear fan	No	Yes	1EX0007
Sled blank	Yes	No	1EX0021

2.6.3 Storage Enclosure Basic specifications

The following table lists the system specifications for an individual Storage Enclosure Basic.

Table 2-10. Storage Enclosure Specifications

Condition	Specification
Operating relative humidity	8% to 90% non-condensing
Operating temperature	41° to 104°F (5°C to 40°C)
Quantity	Six
Rack units	4U
Relative humidity gradient	30% per hour maximum
Temperature de-rating	33.8°F per 984.2 ft above 9842.5 ft (1°C per 300 m above 3000 m)
Temperature gradient	68°F (20°C)/hour
Weight (per component)	236 lbs (107 kg)
Weight (total for all Storage Enclosure Basics)	1416 lbs (642 kg)

2.7 Power Distribution Unit

Note: Rackless X100 configurations use customer-supplied PDUs.

The power distribution units (PDUs) used in the racked ActiveScale X100 are connected at the rear of the system. The PDUs provide redundant power and control inrush during the system power-up.

Note: Use of any other PDUs not qualified by Quantum may result in loss of monitoring.

Figure 2-16. Power distribution unit



2.7.1 PDU component identification

The information in this section will help you identify ActiveScale X100 PDU components.

2.7.1.1 PDU numbering

Note: PDUs are numbered from the rear of the rack.

Figure 2-17. Single-phase PDU numbering

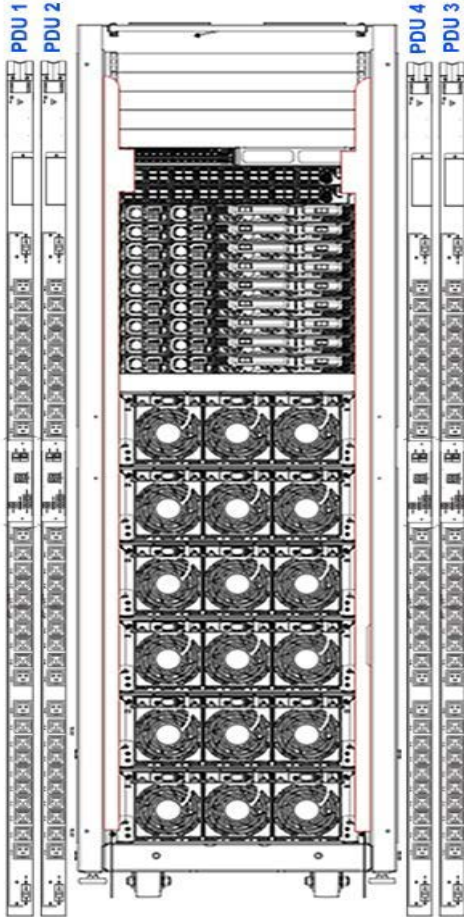
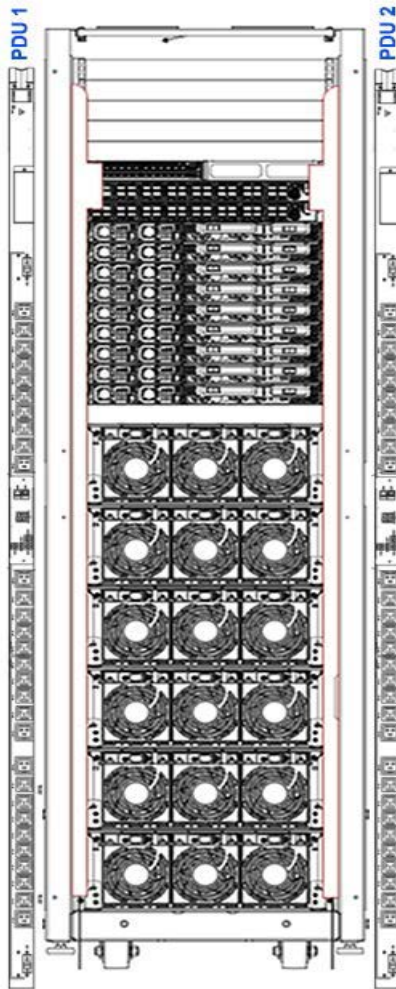

Figure 2-18. Three-phase PDU numbering

2.7.1.2 Power distribution unit LED identification

The LED readouts on the PDU provide information about each phase. The per-phase display helps prevent overloads and simplify single-phase and three-phase load balancing.

Table 2-11. Power distribution unit LED display

Name	LED action	Description
--	Flashing	Internal communication bus error.
bE	Solid	Breaker error
oL	Solid	Overload
UA	Flashing	The identification LED for Unit A Master.
Ub	Flashing	The identification LED for Unit b Slave.
UC	Flashing	The identification LED for Unit d Slave.

2.7.2 Replaceable parts for PDUs

The following table lists the replacement PDUs that are available from Quantum Corporation.

Table 2-12. PDU Replaceable Parts

Replaceable part	Hot swappable?	Part number
3-phase PDU (Delta) L15-30P	Yes ¹	1EX0249
3-phase PDU (Delta) L21-30P	Yes ¹	1EX0262
3-phase PDU (Wye) IEC 60309 16A 4P+E	Yes ¹	1EX0250
3-phase PDU (Wye) IEC 60309 32A 4P+E	Yes ¹	1EX0263
Single-phase PDU IEC 60309 32A 2P+E	Yes ¹	1EX0264
Single-phase PDU NEMA L6-30P	Yes ¹	1EX0251

1. Only if the rack is powered and cabled with recommended N+1 redundancy.

2.7.3 PDU specifications

Table 2-13. Three-phase PDU specification summary

Condition	Three-phase (Delta) L15-30P	Three-phase (Delta) L21-30P	Three-phase (Wye) IEC 60309 16A 4P+E	Three-phase (Wye) IEC 60309 32A 4P+E
Model	STV-4502E	STV-4502M	STV-4503J	STV-6503K
Part number	1EX0249	1EX0262	1EX0250	1EX0263
Hot swappable?	Yes	Yes	Yes	Yes
Quantity (per system)	2	2	2	2
Plug standard	NEMA L15-30P	NEMA L21-30P	IEC 60309 16A 4P+E	IEC 60309 32A 4P+E
Outlet standard	NEMA L15-30R	NEMA L21-30R	IEC 60309 16A 4P+E	IEC 60309 32A 4P+E
Weight	19 lbs (8.6 kg)	20 lbs (9 kg)	21 lbs (9.5 kg)	20 lbs (9 kg)
Dimensions	<ul style="list-style-type: none"> • Width—2.2 in (56 mm) • Depth—2.25 in (58 mm) • Height—69 in (1753 mm) 	<ul style="list-style-type: none"> • Width—2.2 in (56 mm) • Depth—2.25 in (58 mm) • Height—69 in (1753 mm) 	<ul style="list-style-type: none"> • Width—2.2 in (56 mm) • Depth—2.25 in (58 mm) • Height—70 in (1778 mm) 	<ul style="list-style-type: none"> • Width—2.2 in (56 mm) • Depth—2.25 in (58 mm) • Height—70 in (1778 mm)
Rack position	Rear of the rack 0U	Rear of the rack 0U	Rear of the rack 0U	Rear of the rack 0U
Operating temperature	32°F to 140°F (0°C to 60°C)	32°F to 140°F (0°C to 60°C)	32°F to 140°F (0°C to 60°C)	32°F to 140°F (0°C to 60°C)

Table 2-14. Single-phase PDU specification summary

Condition	Single-phase NEMA L6-30P	Single-phase IEC 60309 24A 2P+E
Model	STV-4501C	STV-6501K
Part number	1EX0251	1EX0264
Hot-swappable	Yes	Yes
Condition	Single-phase NEMA L6-30P	Single-phase IEC 60309 24A 2P+E

Condition	Single-phase NEMA L6-30P	Single-phase IEC 60309 24A 2P+E
Quantity (per system)	4	4
Plug standard	NEMA L6-30P	IEC 60309 32A 2P+E
Outlet standard	NEMA L6-30R	IEC 60309 32A 2P+E
Weight	18 lbs (8.1 kg)	18 lbs (8.1 kg)
Dimensions	<ul style="list-style-type: none">• Width—2.2 in (56 mm)• Depth—2.3 in (56 mm)• Height—69 in (1753 mm)	<ul style="list-style-type: none">• Width—2.2 in (56 mm)• Depth—2.25 in (58 mm)• Height—69 in (1753 mm)
Rack position	Rear of the rack 0U	Rear of the rack 0U
Operating temperature	32°F to 140°F (0°C to 60°C)	32°F to 140°F (0°C to 60°C)

2.7.4 Power cords

Use only tested and approved power cords that are connected to either:

- Properly grounded power outlets.
- The insulated sockets of the rack internal power supply.

If an AC power cord was not provided with your product, purchase one that is approved for use in your country.

To avoid electrical shock or fire, check the power cords that will be used with the product as follows:

- The power cord must have an electrical rating that is greater than that of the electrical current rating marked on the product.
- Do not attempt to modify or use the AC power cord(s) if they are not the exact type required to fit into the grounded electrical outlets.
- The power supply cord(s) must be plugged into socket-outlet(s) that is /are provided with a suitable earth ground.
- The power supply cord(s) is / are the main disconnect device to AC power. The socket outlet(s) must be near the equipment and readily accessible for disconnection.

3 Parts replacement steps

This section provides replacement steps for each ActiveScale X100 component.

3.1 PDU part replacement instructions

The following sections provide instructions for servicing PDUs.

3.1.1 Replacing PDUs (single and three-phase)



Warning: Some components are heavy.



Warning: Disconnect all power sources before servicing.

Table 3-15. PDU replacement overview

Required Tools	Personnel	Replacement Time
<ul style="list-style-type: none">• #2 Phillips-Head Screwdriver• Utility knife	1	25 min

Note: The ActiveScale X100 does not need to be powered down to replace a failed PDU due to PDU redundancy. If the system is powered up, the PDU does not need to be renamed. However, if the system is powered down, the PDU will need to be reprogrammed. For more information, refer to [Programming PDUs](#) on page 44.

3.1.1.1 Removing a PDU

To remove a PDU:

1. From the power source, turn off power to the failed PDU.
2. Using a utility knife, remove the nylon ties holding the PDU in place.
3. Disconnect the power cables from the PDU.
4. Disconnect the network cables from the PDU.
5. Remove the screws that attach the PDU to the rack.
6. Pull the power cord and plug out of the top of the rack.

Note: If the power source is located below the rack, you can pull the power cord out from the bottom of the rack.

7. Slide the PDU up and away from the PDU mounting bracket.

Figure 3-19. Removing the single-phase PDU

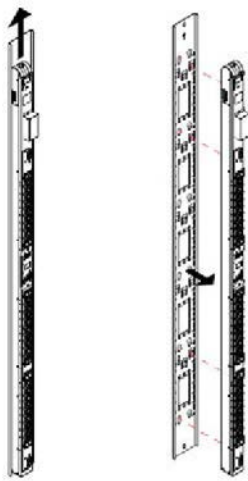

8. Place the failed PDU in a safe place away from the system.

3.1.1.2 Installing a PDU

To install a replacement PDU:

1. From the rear of the rack, feed the plug through the opening in the top of the rack. Ensure the plug is draped over the rack in a safe location and will not fall back through the hole.

Note: The PDU cables can also go through the bottom of the rack if the power source is below the rack.

2. Line up the PDU over the mounting holes.
3. Place the mounting pegs over the rack PDU mounting points and pull down.

Figure 3-20. Installing the single-phase PDU

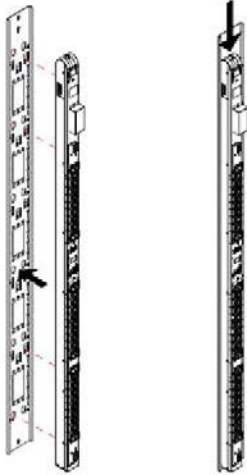

Important: If you are not replacing PDU 1, the system components **SHOULD NOT** be plugged into the powered PDU yet. Without programming, there will be no staggered power to manage inrush or ensure that components are powered on in the correct order. Follow the instructions in [Programming PDUs](#) on page 44 before reconnecting power.

4. Secure the new PDU to the rack using nylon ties.
5. Using the cable labels for reference, reconnect all of the cables to the proper port. Refer to [System cabling](#) on page 117 for more information.
6. Connect the PDU to the power source and power it on.
7. Verify that there are no error messages displayed on the PDU and that it is functioning properly.

3.1.2 Programming PDUs

Important: The steps in this section are only required if you are installing a PDU that is not PDU 1. If you are replacing PDU 1, skip this section.

Replacement PDUs are programmed to function as PDU 1 in the rack. If you are not replacing PDU 1, you must reprogram the PDU. Reprogramming the PDU includes:

- Changing the PDU name.
- Changing the delays and power on sequence for the system components.

PDU reprogramming is done using the PDU firmware CLI. You can access the CLI using one of the following methods:

- A serial (RS232) port
- An Ethernet port

3.1.2.1 Connecting to the PDU with a serial port

The PDU has an RJ45 serial RS-232 port. Use a RJ45-to-DB9F serial port adapter to connect using a PC or networked terminal server.

Serial port connections require either a terminal or terminal emulation software configured to support VT100/ANSI. The serial port also requires the following settings:

- Baud: **9600**
- Data Bits: **8**
- Parity: **None**
- Stop Bits: **1**
- Flow Control: **None**

3.1.2.2 Connecting to the PDU with an Ethernet port

The PDU is also equipped with an RJ45 10/100Base-T Ethernet port. Use this connection to access the PDU firmware CLI with Telnet.

The PDU Ethernet port uses the following default settings:

- IP Address: **192.168.1.254**
- Subnet Mask: **255.255.255.0**
- Gateway: **192.168.1.1**

Configure a PC Ethernet port with a static IP address in the range 192.168.1.2-253 to enable communication with the PDU Ethernet port.

Use the PDU IP address when initiating the Telnet session:

```
telnet 192.168.1.254
```

3.1.2.3 Logging into the PDU Firmware CLI

After connecting to the PDU firmware CLI, use the following credentials to log in:

- **Username:** admn
- **Password:** admn

After logging in, input the relevant commands for your PDU.

3.1.2.4 Three-phase PDU programming with three PDUs

- PDU 1

```
show system
show units
set unit name A PDU-1
set access prompt Switched CDU:
set outlet name AA1 UNUSED1
set outlet name AA2 UNUSED2
set outlet name AA3 UNUSED3
set outlet name AA4 JBOD1
set outlet name AA5 CSN1
set outlet name AA6 JBOD2
set outlet name AA7 CSN2
set outlet name AA8 UNUSED8
set outlet name AA9 UNUSED9
set outlet name AA10 UNUSED10
set outlet name AA11 UNUSED11
set outlet name AA12 TORSW1
set outlet name AA13 JBOD3
set outlet name AA14 UNUSED14
set outlet name AA15 UNUSED15
set outlet name AA16 CSN3
set outlet name AA17 UNUSED17
set outlet name AA18 SN2
set outlet name AA19 SEN2
set outlet name AA20 UNUSED20
set outlet name AA21 UNUSED21
set outlet name AA22 TORSW2
set outlet name AA23 UNUSED23
set outlet name AA24 SN3
set outlet name AA25 JBOD6
set outlet name AA26 UNUSED26
set outlet name AA27 CSN6
set outlet name AA28 SEN3
set outlet name AA29 UNUSED29
set outlet name AA30 UNUSED30
set outlet extondelay AA1 0
set outlet extondelay AA2 0
set outlet extondelay AA3 0
set outlet extondelay AA4 20
set outlet extondelay AA5 40
set outlet extondelay AA6 50
set outlet extondelay AA7 60
set outlet extondelay AA8 0
set outlet extondelay AA9 0
set outlet extondelay AA10 0
set outlet extondelay AA11 0
set outlet extondelay AA12 0
set outlet extondelay AA13 10
```

```
set outlet extondelay AA14 0
set outlet extondelay AA15 0
set outlet extondelay AA16 50
set outlet extondelay AA17 0
set outlet extondelay AA18 20
set outlet extondelay AA19 30
set outlet extondelay AA20 0
set outlet extondelay AA21 0
set outlet extondelay AA22 0
set outlet extondelay AA23 0
set outlet extondelay AA24 20
set outlet extondelay AA25 40
set outlet extondelay AA26 0
set outlet extondelay AA27 60
set outlet extondelay AA28 30
set outlet extondelay AA29 0
set outlet extondelay AA30 0
set outlet seqdelay 0
set dhcp staticfallback disabled
reboot ALL
```

- PDU 2

```
show system
show units
set unit name A PDU-2
set access prompt Switched CDU:
set outlet name AA1 UNUSED1
set outlet name AA2 MSW
set outlet name AA3 SN1
set outlet name AA4 JBOD1
set outlet name AA5 CSN1
set outlet name AA6 UNUSED6
set outlet name AA7 UNUSED7
set outlet name AA8 SEN1
set outlet name AA9 UNUSED9
set outlet name AA10 UNUSED10
set outlet name AA11 UNUSED11
set outlet name AA12 TORSW1
set outlet name AA13 UNUSED13
set outlet name AA14 UNUSED14
set outlet name AA15 JBOD4
set outlet name AA16 UNUSED16
set outlet name AA17 CSN4
set outlet name AA18 SN2
set outlet name AA19 SEN2
set outlet name AA20 UNUSED20
set outlet name AA21 UNUSED21
set outlet name AA22 UNUSED22
set outlet name AA23 JBOD5
set outlet name AA24 UNUSED24
```

```
set outlet name AA25 JBOD6
set outlet name AA26 CSN5
set outlet name AA27 CSN6
set outlet name AA28 UNUSED28
set outlet name AA29 UNUSED29
set outlet name AA30 UNUSED30
set outlet extondelay AA1 0
set outlet extondelay AA2 0
set outlet extondelay AA3 10
set outlet extondelay AA4 20
set outlet extondelay AA5 40
set outlet extondelay AA6 0
set outlet extondelay AA7 0
set outlet extondelay AA8 30
set outlet extondelay AA9 0
set outlet extondelay AA10 0
set outlet extondelay AA11 0
set outlet extondelay AA12 0
set outlet extondelay AA13 0
set outlet extondelay AA14 0
set outlet extondelay AA15 40
set outlet extondelay AA16 0
set outlet extondelay AA17 60
set outlet extondelay AA18 20
set outlet extondelay AA19 30
set outlet extondelay AA20 0
set outlet extondelay AA21 0
set outlet extondelay AA22 0
set outlet extondelay AA23 10
set outlet extondelay AA24 0
set outlet extondelay AA25 40
set outlet extondelay AA26 50
set outlet extondelay AA27 60
set outlet extondelay AA28 0
set outlet extondelay AA29 0
set outlet extondelay AA30 0
set outlet seqdelay 0
set dhcp staticfallback disabled
reboot ALL
```

- PDU 3

```
show system
show units
set unit name A PDU-3
set access prompt Switched CDU:
set outlet name AA1 UNUSED1
set outlet name AA2 UNUSED2
set outlet name AA3 SN1
set outlet name AA4 UNUSED4
set outlet name AA5 UNUSED5
```

```
set outlet name AA6 JBOD2
set outlet name AA7 CSN2
set outlet name AA8 SEN1
set outlet name AA9 UNUSED9
set outlet name AA10 UNUSED10
set outlet name AA11 UNUSED11
set outlet name AA12 UNUSED12
set outlet name AA13 JBOD3
set outlet name AA14 UNUSED14
set outlet name AA15 JBOD4
set outlet name AA16 CSN3
set outlet name AA17 CSN4
set outlet name AA18 UNUSED18
set outlet name AA19 UNUSED19
set outlet name AA20 UNUSED20
set outlet name AA21 UNUSED21
set outlet name AA22 SW2
set outlet name AA23 JBOD5
set outlet name AA24 SN3
set outlet name AA25 UNUSED25
set outlet name AA26 CSN5
set outlet name AA27 UNUSED27
set outlet name AA28 SEN3
set outlet name AA29 UNUSED29
set outlet name AA30 UNUSED30
set outlet extondelay AA1 0
set outlet extondelay AA2 0
set outlet extondelay AA3 10
set outlet extondelay AA4 0
set outlet extondelay AA5 0
set outlet extondelay AA6 50
set outlet extondelay AA7 60
set outlet extondelay AA8 30
set outlet extondelay AA9 0
set outlet extondelay AA10 0
set outlet extondelay AA11 0
set outlet extondelay AA12 0
set outlet extondelay AA13 10
set outlet extondelay AA14 0
set outlet extondelay AA15 40
set outlet extondelay AA16 50
set outlet extondelay AA17 60
set outlet extondelay AA18 0
set outlet extondelay AA19 0
set outlet extondelay AA20 0
set outlet extondelay AA21 0
set outlet extondelay AA22 0
set outlet extondelay AA23 10
set outlet extondelay AA24 20
set outlet extondelay AA25 0
```



```

set outlet extondelay AA26 50
set outlet extondelay AA27 0
set outlet extondelay AA28 30
set outlet extondelay AA29 0
set outlet extondelay AA30 0
set outlet seqdelay 0
set dhcp staticfallback disabled
reboot ALL

```

3.2 Management Interconnect part replacement instructions

The following sections provide information about Management Interconnect part replacement.

Important: Racked and rackless ActiveScale X100 systems use different mounting kits. Ensure that you are following the correct procedure for your system.

3.2.1 Replacing Management Interconnects (rackless system)



Caution: Disconnect all power sources before servicing.

Table 3-16. Rackless system Management Interconnect replacement overview

Required Tools	Personnel	Replacement Time
#2 Phillips head screwdriver with torque measuring capabilities.	1	15 min

3.2.1.1 Removing the Management Interconnect from a rackless system

To remove the Management Interconnect from a rackless ActiveScale X100:

Tip: Before you begin, go to the rear of the rack and confirm that the cables connected to the Management Interconnect are correctly labeled. The labels will help you reconnect the cables later.

1. Disconnect the cables from the back of the Management Interconnect.
2. From the back of the rack, remove the four screws from the Management Interconnect rack adapters.

Figure 3-21. Management Interconnect rack ears



3. With the rack adapters still attached, remove the Management Interconnect from the rack.
4. Remove the screws securing the rack adapters to the Management Interconnect.

Important: Retain the rack adapters and screws. They will be used with the replacement Management Interconnect.

5. Record the serial number of the faulty device for return purposes.

3.2.1.2 Installing the Management Interconnect into a rackless system

Important: Replacement Management Interconnects do not come with new rack adapters and screws. Use the rack adapters that you removed from the faulty Management Interconnect. If you need replacement rack adapters, contact Quantum Corporation support.

Note: Depending on the configuration of the rack, you might need to reconnect the cables before putting the Management Interconnect into the rack.

To install a replacement Management Interconnect into a rackless ActiveScale X100 system:

1. Screw the rack adapters into both sides of the Management Interconnect.

Figure 3-22. Management Interconnect with rack adapters



2. From the back of the rack, position the rack adapters over the cage nuts.
3. Using the four screws, secure the adapters into places.
4. Reconnect the cables in the back of the Management Interconnect.

3.2.2 Replacing Management Interconnects (racked system)



Caution: Disconnect all power sources before servicing.

Table 3-17. Racked system Management Interconnect replacement overview

Required Tools	Personnel	Replacement Time
#2 Phillips head screwdriver with torque measuring capabilities.	1	15 min

3.2.2.1 Removing the Management Interconnect from a racked system

To remove the Management Interconnect from a racked ActiveScale X100:

Tip: Before you begin, go to the rear of the rack and confirm that the cables connected to the Management Interconnect are correctly labeled. The cable labels will help you reconnect the cables later.

1. Remove the Management Interconnect tray from the rack.
 - a. Disconnect the network cables from the rear of the Management Interconnect.
 - b. Remove the blanking panel from the front of the Management Interconnect.
 - c. Pull the rails attached to the Management Interconnect half way out of the rail mounts.
 - d. Remove the power cable.
 - e. Remove the Management Interconnect from the rack.

Figure 3-23. Removing the Management Interconnect from the Rack

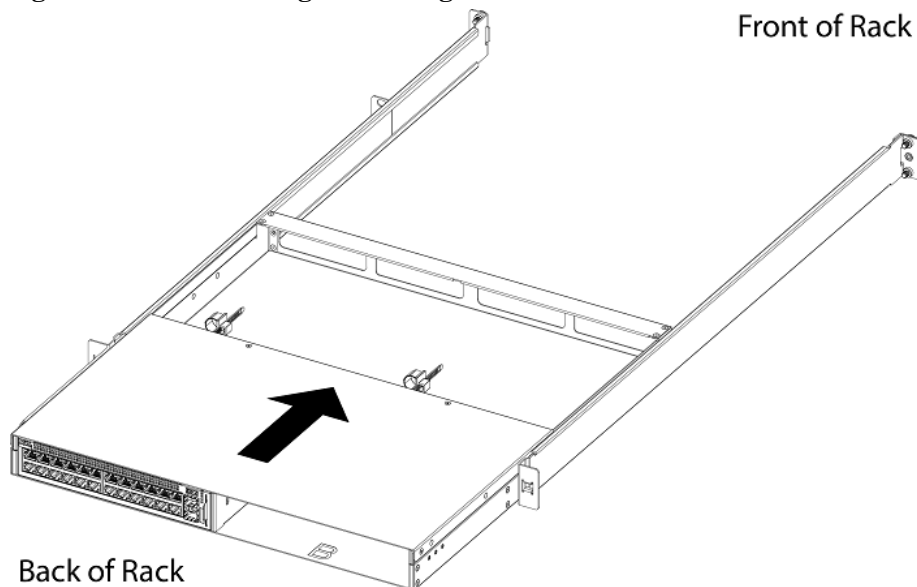

2. Place the Management Interconnect tray on a stable, ESD-safe surface.
3. Remove the Management Interconnect from the tray.
 - a. Remove the two top front screws from the tray.
 - b. Slide the cover towards the front of the tray and lift up.

Figure 3-24. Removing the Management Interconnect cover

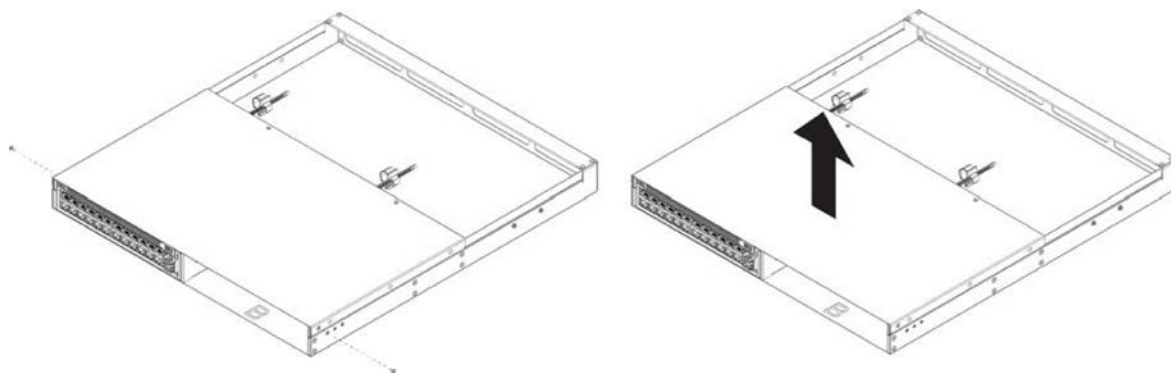

- c. Lift the Management Interconnect out of the tray.

Figure 3-25. Removing the old Management Interconnect

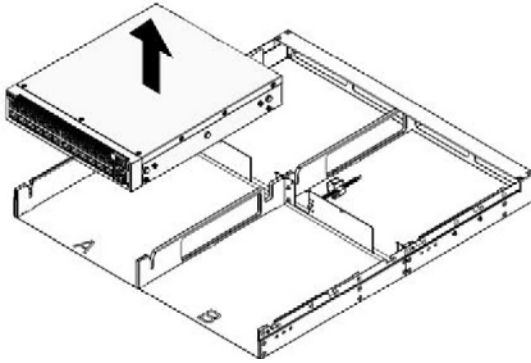

3.2.2.2 Installing the Management Interconnect into a racked system

To install a replacement Management Interconnect into a racked ActiveScale X100 system:

- 1. Install the new Management Interconnect into the tray.
 - a. Set the new Management Interconnect into the tray.

Figure 3-26. Installing the new Management Interconnect

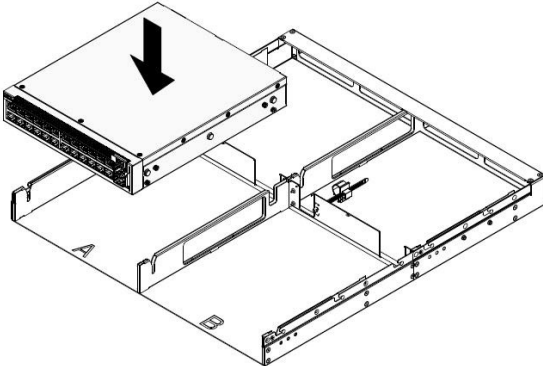

- b. Place the cover on top of the tray and slide it towards the rear of the tray.
- c. Secure the cover on the tray with the top front screws.

Figure 3-27. Installing the Management Interconnect cover

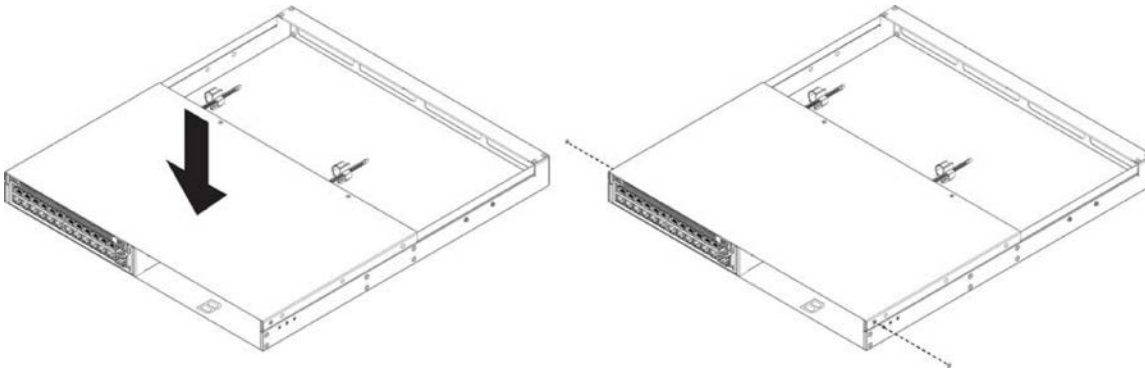

- From the front of the rack, slide the Management Interconnect halfway into the rack.

Figure 3-28. Installing the Management Interconnect in the Rack

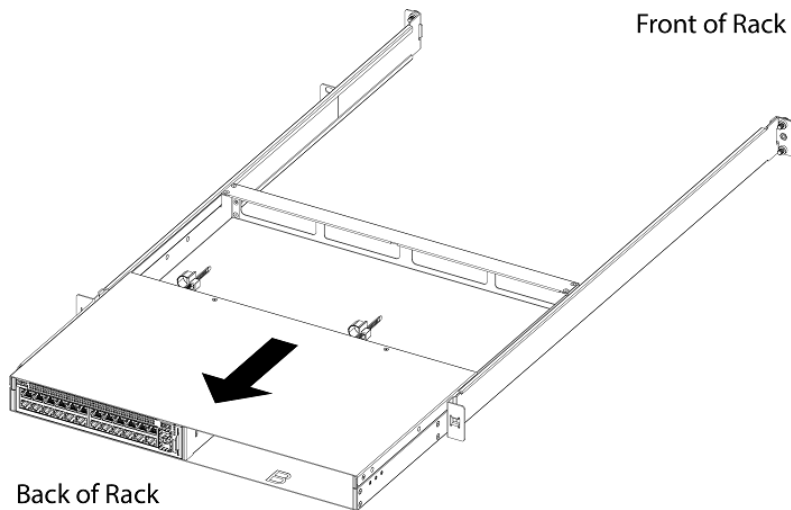

- Connect the power cord plugged into the Management Interconnect.
- Slide the Management Interconnect the rest of the way into the rack.
- From the front of the rack, re-attach the blanking panel in front of the Management Interconnect.
- From the rear of the rack, connect the networking cables plugged into the Management Interconnect.

Note: For more information on cabling the Management Interconnect, see [System cabling](#) on page 117.

3.3 System Interconnect part replacement instructions

The following sections provide instructions for servicing System Interconnect components.

3.3.1 Replacing System Interconnect fans

Table 3-18. System Interconnect fan replacement overview

Required tools	Personnel required	Replacement time
None	1	15 to 25 minutes

Tip: Replacing the fans might require the use of a ladder or flashlight. This is because System Interconnects are biased towards the rear of the rack, but are only accessible from the front. This means that you might have difficulty locating the fans in a standard configuration.

3.3.1.1 Removing a System Interconnect fan

To remove the System interconnect fan:

- Remove the blanking panel from the System Interconnect mounting kit.
 - Remove the thumb screw from the front of the blanking panel.
 - Grasp the blanking panel by the front cutouts.

- c. Pull the blanking panel from the mounting kit.

Note: You might have to remove adjacent blanking panels to fully access the 3U mounting kit or System Interconnects.

2. Identify the malfunctioning fan at the back of the System Interconnect.
3. Grasp the clips and pinch to unlatch the fan from the system.
4. With even pressure, pull the fan out of the system.
5. Record the serial number of the faulty device for return purposes.

3.3.1.2 Installing a System Interconnect fan

To install a replacement System Interconnect fan:

1. Align the replacement fan to the empty slot.
2. With even pressure, push the replacement fan into the system until there is an audible click. The fan should begin operating immediately.
3. Replace the blanking panels at the front of the system.

3.3.2 Replacing System Interconnect PSUs

Caution: Be careful not to accidentally remove the power cord of the second PSU. This will bring the System Interconnect down and cause data loss.

Table 3-19. System Interconnect PSU replacement overview

Required tools	Personnel required	Replacement time
None	1	15 to 25 minutes

Tip: Replacing the PSU might require the use of a ladder or flashlight.

3.3.2.1 Removing a System Interconnect PSU

To remove a System Interconnect PSU:

1. Remove the blanking panel from the System Interconnect mounting kit.
 - a. Remove the thumb screw from the front of the blanking panel.
 - b. Grasp the blanking panel by the front cutouts.
 - c. Pull the blanking panel from the mounting kit.

Note: You might have to remove adjacent blanking panels to fully access the 3U mounting kit or System Interconnects.

2. Remove the PSU power cable.
3. Press the latch release lever. This action releases the PSU from the System Interconnect.

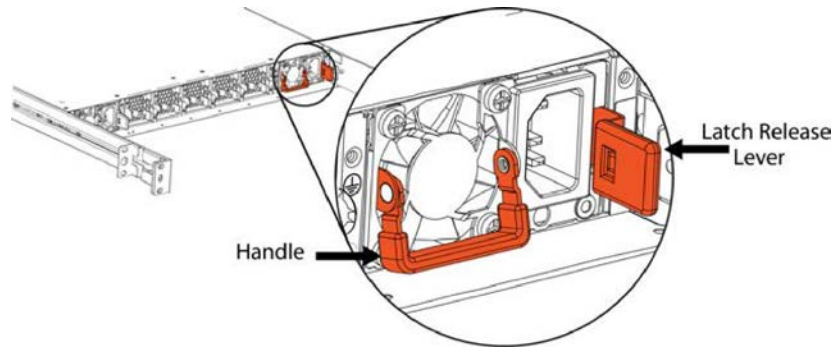
Figure 3-29. Latch release lever and handle

4. Grasp the handle and pull with even pressure until the PSU is removed from the system.

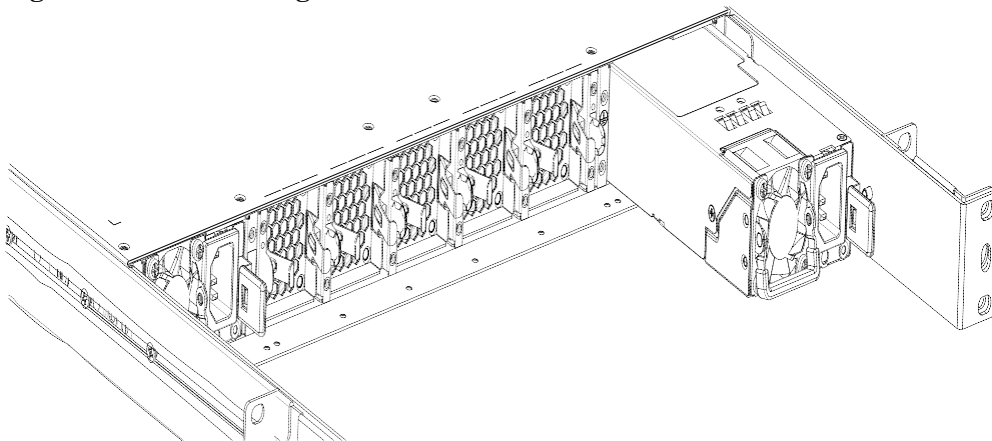
Figure 3-30. Removing the PSU

5. Record the serial number of the faulty device for return purposes.

3.3.2.2 Installing a System Interconnect PSU

To install a replacement System Interconnect PSU:

1. Align the replacement PSU to the empty slot.
2. Push with even pressure until there is an audible click.
3. Plug the power cord into the new PSU.
4. Replace the blanking panels at the front of the system.

3.3.3 Replacing QSFP+ 40G transceivers

Table 3-20. System Interconnect QSFP+ 40G transceiver replacement overview

Required tools	Personnel required	Replacement time
None	1	5 to 10 min

3.3.3.1 Removing a System Interconnect QSFP+ 40G transceiver

To remove a QSFP+ 40G transceiver:

1. From the rear of the rack, remove the fiber optic cable from the failed transceiver.
2. Pull the transceiver loop until it is unseated from the port.

3. Remove the transceiver from the System Interconnect.
4. Record the serial number of the faulty component for return purposes.

Figure 3-31. QSFP+ transceiver uninstalled

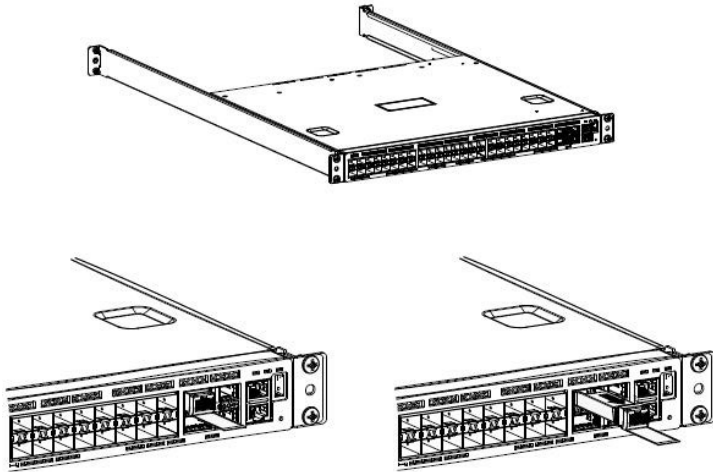

3.3.3.2 Installing a System Interconnect QSFP+ 40G transceiver

To install a replacement QSFP+ 40G transceiver:

1. From the rear of rack, with the label facing down, insert the transceiver into the Management port.
2. Push on the rear of the transceiver until there is an audible click.

Figure 3-32. QSFP+ transceiver installed

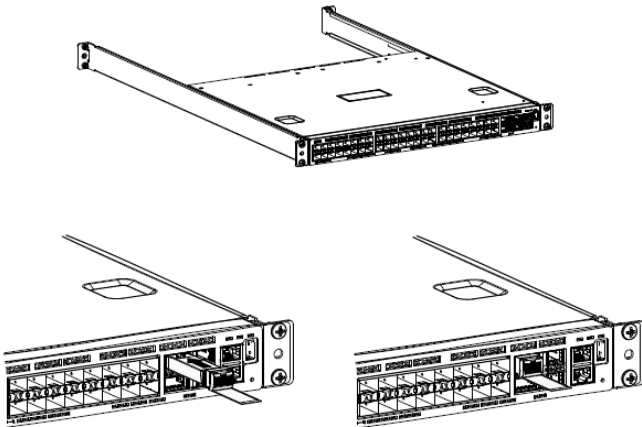

3. Insert both of the fiber optic cables into the QSFP+ transceiver.

3.3.4 Replacing System Interconnects

Caution: If your System Interconnects use a custom configuration, contact Quantum Corporation support to obtain the custom configuration file before proceeding.

Table 3-21. System Interconnect Replacement Overview

Required tools	Personnel required	Replacement time
None	1	60 to 75 minutes

Caution: Taking down a System Interconnect for replacement will limit bandwidth availability.

3.3.4.1 Removing a System Interconnect

To remove a System Interconnect:

1. Remove the blanking panel from the System Interconnect mounting kit.
 - a. Remove the thumb screw from the front of the blanking panel.
 - b. Grasp the blanking panel by the front cutouts.
 - c. Pull the blanking panel from the mounting kit.

Note: You might have to remove adjacent blanking panels to fully access the 3U mounting kit or System Interconnects.

2. At the rear of the rack, remove the network cables from the front of the System Interconnect.
3. At the front of the rack, remove the power cords from the rear of the System Interconnect.
4. Locate and unscrew the retention screws on the front of the system that secure the 3U mounting kit adapter to the rack.
5. Gripping the System Interconnect firmly with both hands, pull forward with even pressure until it releases from the rack.

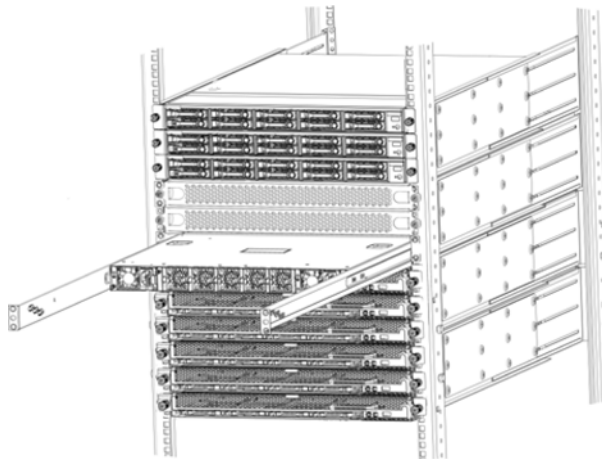
Figure 3-33. Removing System Interconnects

6. Record the serial number on the faulty component for return purposes.

3.3.4.2 Installing a System Interconnect

To install a replacement System Interconnect:

1. Align the replacement System Interconnect with the empty space in the rack and slide it completely into the rack.

2. From the front of the rack, reconnect the two power cords to the back of the System Interconnect.
3. Secure the blanking panels using the thumbscrews.
4. Reconnect all of the networking cables using the [Cabling Map](#) on page 66.

3.3.4.3 Programming a System Interconnect

Important: The steps in this section are only required if you are replacing System Interconnect 2.

Replacement System Interconnects are programmed to function as System Interconnect 1 in the rack. If you are replacing System Interconnect 2, it must be reprogrammed.

To program a System Interconnect:

1. Obtain the correct System Interconnect configuration file for your system from Quantum Corporation support.
2. Edit the System Interconnect configuration file as follows:
 - a. Modify the IP address for the syslog target to match your environment.
 - b. Modify the IP address for VLAN to match your environment.
 - c. Modify the time and time zone to match your environment.
3. Connect your computer to the Ethernet port on the System Interconnect.
4. Configure your computer manually to be on the same network as the System Interconnect with the following values:
 - Management Port: 192.168.123.0/24
 - Subnet: 255.255.255.0
 - Gateway: 192.168.123.123
5. Open a Telnet session to the replacement System Interconnect and replace *switchport_IP* with the default IP address 192.168.123.123.
The System Interconnect command prompt appears.
6. Log in using the default credentials (user name admin, no password).
7. Type `enable` to enter the Privileged EXEC command mode.

```
(Routing)>enable
```

8. Type `configure` to enter the Privileged CONF command mode.

```
(Routing)#configure  
(Routing)(Config)#
```

9. Configure the name of the switch.

```
(Routing)(Config)#DC01-SW02  
(DC01-SW02)#
```

Replace DC01 with the data center index you use for this data center. Replace SW01 with SW02 if you are replacing the upper System Interconnect.

The prompt changes to the new name of the switch.

10. Copy the entire contents of your modified System Interconnect configuration file, and paste it into the telnet session.
11. Save the new configuration.

```
(DC01-SW02) #write memory
Are you sure you want to save? (y/n) y
Config file 'startup-config' created
successfully. Configuration Saved!
```

This operation may take a few minutes. Management interfaces are not available during this time.

12. Verify that the settings on the System Interconnect match your configuration file.

```
(DC01-SW02) #show startup-config
```

3.4 System Node part replacement instructions

The follow sections provide instructions for servicing System Node components.

3.4.1 Replacing System Node drives (SSD and HDD)

The replacement procedures in this section apply to both the SSD and HDD drives at the front of the system.

Table 3-22. System Node drive replacement overview

Required tools	Personnel required	Replacement time
None	1	15 to 25 minutes

3.4.1.1 Removing a System Node drive

To remove a System Node drive:

1. If you are replacing a faulty drive, locate the drive and verify that is in the **Decommissioned** state.

Important: The replacement drive must be the same model as the drive that you are replacing. Also, the disk must be completely empty, with no data and no partition table.

Important: If you are removing drives as part of System or Storage Node replacement, skip steps a through f.

- a. On the **ActiveScale SM Dashboard**, click the **Resources** tab.
- b. In the system image on the resources page, click the node with the faulty drive. The node will have an alert icon, and the node status page will appear.
- c. Scroll down the page to the components lists and click the tab for HDDs or SSDs depending on which type of drive has failed.
- d. Look through the list of drives and locate the faulty drive. The status column for the drive will read **Degraded**, **Decommissioning**, or **Decommissioned**.

Note: For more information about drive states, refer to the *ActiveScale OS Administrator Guide*.

- If the status is **Degraded**, the drive has displayed problematic behavior and will undergo automatic repair. If the problematic behavior continues, the drive will be decommissioned.

Important: Do not remove a drive in the **Degraded** state. If the drive returns to the **Online** state, the automatic repairs were successful and no further action is required.

- If the status is **Decommissioning**, the drive is either undergoing automatic repair, or is being prepared for safe removal from the system. When it is safe to remove the drive, the state will change to **Decommissioned**.

Important: Do not remove drives in the **Decommissioning** state. If the drive never reaches the **Decommissioned** state, contact Quantum Corporation support.

- If the status is **Decommissioned**, proceed with physical drive replacement.
- e. Click the **Ident** button to light the front identification LED on the drive.
 - f. Identify the physical location of the drive.
2. Press the release button on the drive carrier to release the handle.
 3. Pull the drive out of the slot with even pressure.

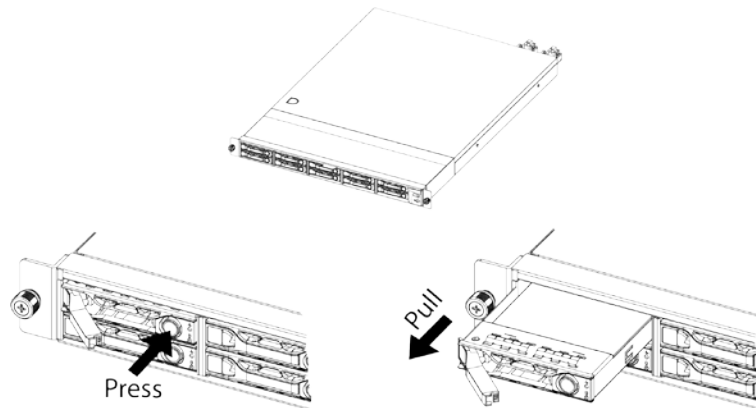
Figure 3-34. Removing a drive

- Record the serial number of the failed device for return purposes.

3.4.1.2 Installing a System Node drive

To install a replacement System Node drive:

- Insert the replacement drive into the empty slot left by the faulty drive.
- Place one finger on each side of the drive and press with even pressure until the drive stops.
- Swing the release handle back into the carrier to fully seat the drive into the slot. When the drive is inserted, the LEDs on the drive carrier will light up as the drive is being integrated into the system.
- Wait for the activity LED to start begin flashing to be sure the drive is integrated successfully.
- Check to make sure that the drive has been reintegrated and the status is **Online**. If the status is **Degraded**, **Decommissioning**, or **Decommissioned**, wait for approximately 15 minutes and check again.

Important: If the status does not change to **Online**, retry the replacement process or contact Quantum Corporation Support.

3.4.2 Replacing System Node PSUs

Caution: Be careful not to accidentally remove the power cord of the second PSU. This will power down the System Node and can cause data loss.

Table 3-23. System Node PSU replacement overview

Required tools	Personnel required	Replacement time
None	1	15 to 25 minutes

3.4.2.1 Removing a System Node PSU

To remove a System Node PSU:

- Unplug the AC power cord from the faulty PSU.

2. Press the release lever in towards the handle to release the PSU from the server.
3. Grasp the handle and pull with even pressure until the unit is removed.

Figure 3-35. Scalar Node PSU handle and latch release

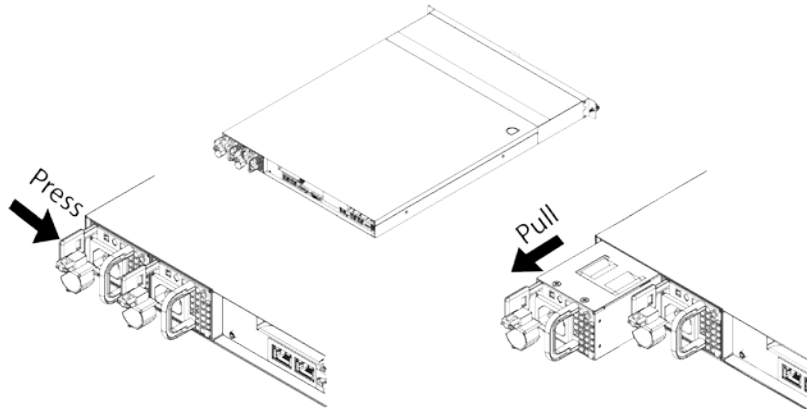

4. Record the serial number of the failed device for return purposes.

3.4.2.2 Installing a System Node PSU

To install a replacement System Node PSU:

1. Align the replacement PSU to the empty slot with the handle facing inward and the release tab facing outward.
2. Push the PSU into the server until there is an audible click.
3. Reconnect the AC power cord.
4. Once the power cord is connected, check that the LED on the rear of the PSU is green.

3.4.3 Replacing SFP+ transceivers

The Small Form-factor Pluggable Plus (SFP+) ports support high density data transfers between the System Node and System Interconnects at a rate of up to 10Gbit/s. This connection also controls commands, diagnostic information, and component information to the host.

Table 3-24. SFP+ transceiver replacement overview

Required tools	Personnel required	Replacement time
None	1	5 to 10 minutes

3.4.3.1 Removing a SFP+ transceiver

To remove an SFP transceiver:

1. From the rear of the rack, remove the fiber optic cables from the failed SFP+ transceiver on the System Node.

2. Remove the transceiver from the server.
3. Open the SFP+ transceiver latch and remove the LC cable connector.
4. Remove the SFP+ transceiver from the System Node.

Figure 3-36. SFP+ transceiver removal

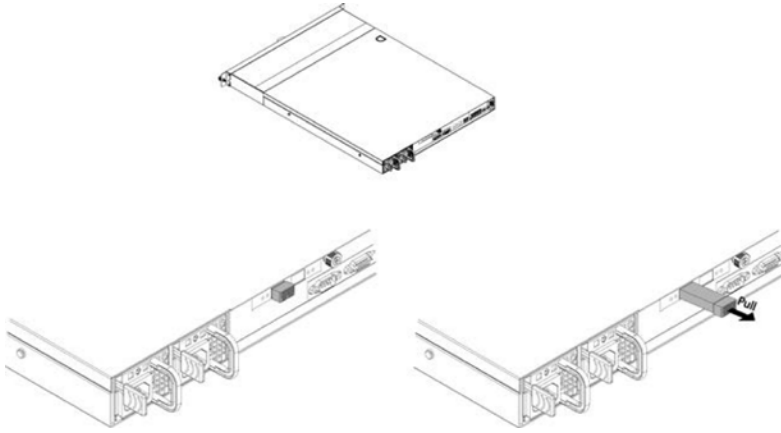

5. Record the serial number of the failed device for return purposes.

3.4.3.2 Installing a SFP+ transceiver

To install a replacement SFP+ transceiver:

1. Open the latch on the SFP+ transceiver.

2. From the rear of rack with the label facing down, insert the SFP+ transceiver into the SFP+ port on the System Node.
3. Close the latch on the SFP+ transceiver.

Figure 3-37. SFP+ transceiver installation

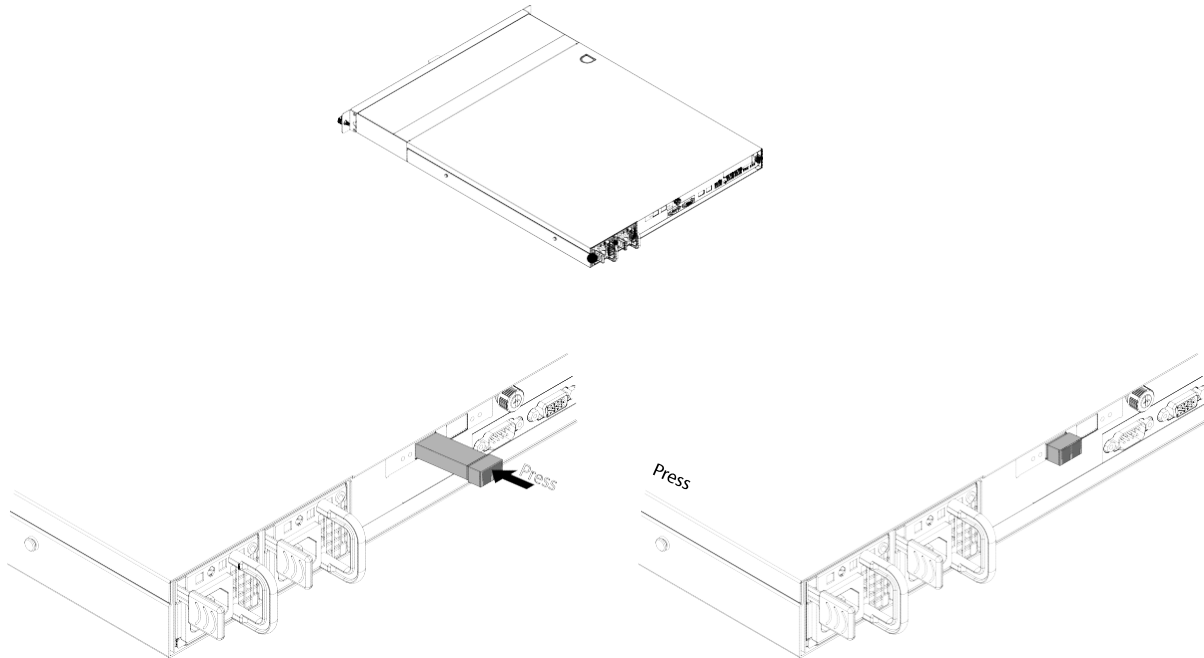

4. Insert both of the fiber optic cables into the replacement SFP+ transceiver.
5. Check to make sure that the activity LED on the port where the SFP+ transceiver replacement occurred is blinking steadily. This behavior confirms that data is being transmitted along that port.

3.4.4 Replacing System Nodes



Caution: The System Node weights 27 lbs (12.2 kg). Take precautions when handling the System Node.



Caution: Disconnect all power sources before servicing.



Caution: Verify that the power cables are not damaged. If they are damaged, they may be a shock hazard and the system may need to be shutdown to replace the server.

Table 3-25. System Node replacement overview

Required tools	Personnel	Replacement time
#2 Phillips Head Screwdriver	1	25 min

3.4.4.1 Removing a System Node

To remove a System Node:

Tip: Before you begin, verify that the cables connected to the System Node are labeled properly so they can be reconnected in the same order.

1. Shut down the node. If the node is already powered down (for example, because it has failed), skip this step.

Important: Do not shut down a node unless all other nodes are healthy.

Figure 3-38. Resources > Rack > Node > Shutdown

er: r00001 Hardware Failures:

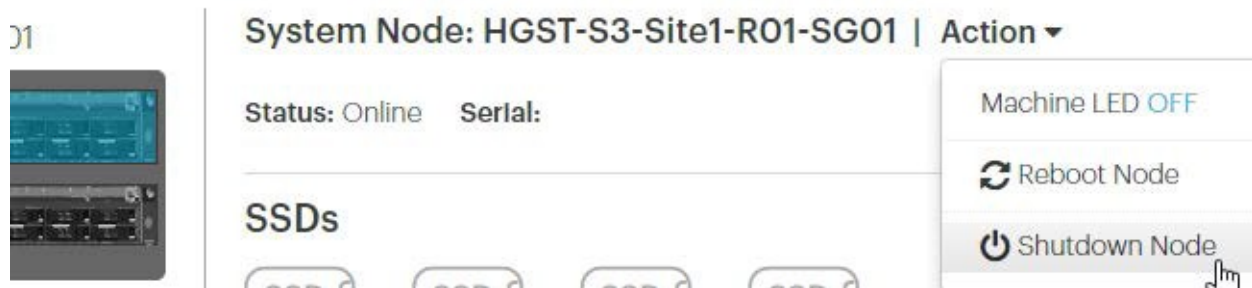

- a. Click **Resources**.
- b. On multi-site systems, select a site from the **Sites** pull-down menu.
- c. In the **Racks** pull-down menu, select a system.
- d. In the rack graphic, select the node you want to shut down. Typically, the node you want to shut down has a failure icon overlay.
- e. In the node's **Actions** pull-down menu, select **Shutdown Node**.
- f. A pop-up appears asking you to confirm that all other nodes in the system are healthy. If so, type the password for `admin` and click **Shutdown**.

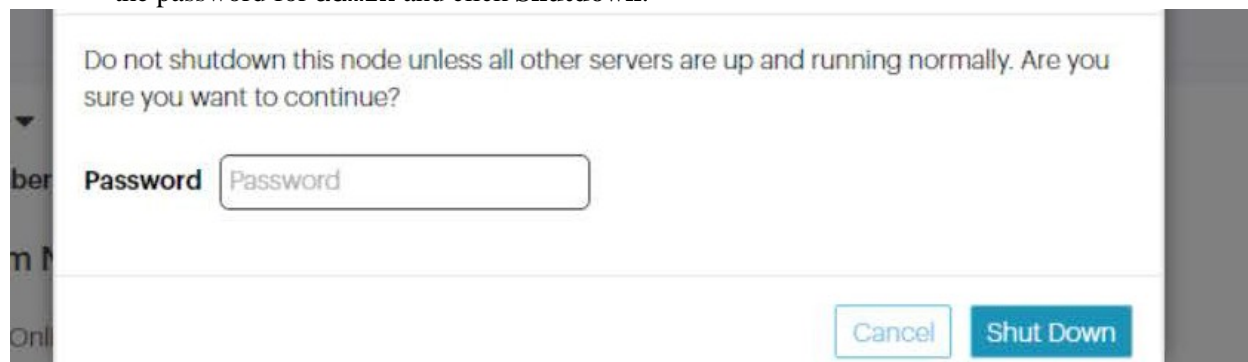

- g. Wait for ActiveScale SM to display a notification in a green banner indicating that the node was shut down successfully:

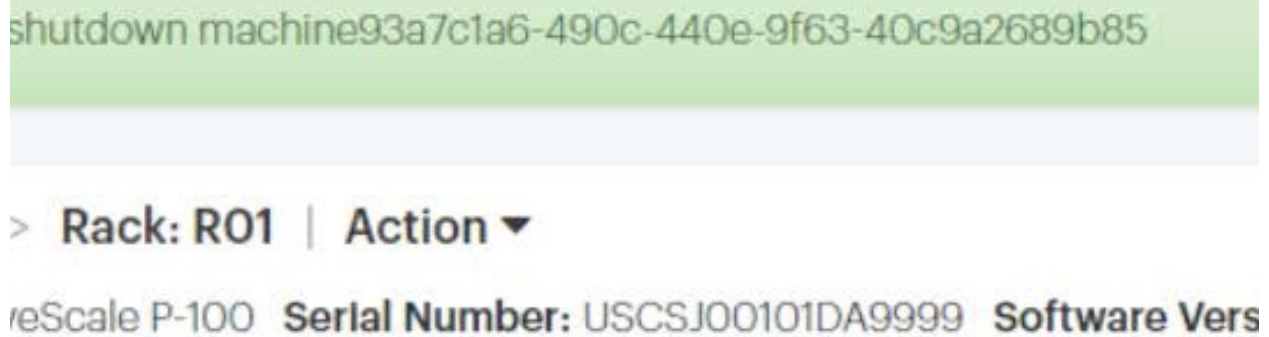

- h. Confirm that you shut down the right node by checking that its front and back LEDs are off.
2. Disconnect all the cables from the System Node.
 3. Remove all of the drives from the front of the System Node. For more information, refer to the section [Removing a System Node drive](#) on page 61.
 4. Unscrew the thumb screws on the front of the System Node. From this point, the removal procedure for the System Node differs based on the mounting kit used. **(1U mounting kit only, skip for 3U mounting kits)** Grasp the System Node and pull with even pressure until the System Node will not extend further.
 5. **(1U mounting kit only, skip for 3U mounting kits)** Unlatch the System Node from the rack.
 - a. Locate the release lever on the side of the System Node.

Figure 3-39. Release Levers

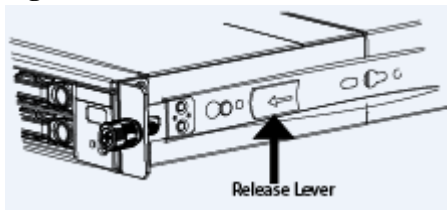

- b. Press the latch release levers toward the front of the System Node. The System Node is now free from the rack and can be fully removed.
6. Carefully remove the System Node from the system.
7. **(1U mounting kit only, skip for 3U mounting kits)** For safety, push the rails that are extending out of the front of the rack back into the rack.
 - a. Press the white release lever on the inside of the outer rails towards the front of the System Node.
 - b. Push the rails into the rack.
8. **(1U mounting kit only, skip for 3U mounting kits)** Remove the rails from the faulty System Node
 - a. Unscrew the two screws that attach the rails to the System Node.
 - b. Slide the rails from the faulty System Node.
9. Record the serial number for return purposes. The serial number and part number are located on a pull-out tab located at the top of the System Node.

3.4.4.2 Installing a System Node

The installation procedure for the System Node differs based on the mounting kit used. For more information about 3U mounting kits, refer to [Replacing 3U mounting kits](#) on page 62. To install a System Node:

1. **(1U mounting kit only, skip for 3U mounting kits)** Attach the inner rails to the new System Node.
 - a. Align the holes in the inner rail with the pegs on the side of the System Node.
 - b. Slide the rail forward to lock it in place.

Figure 3-40. Locking the inner rail to the System Node

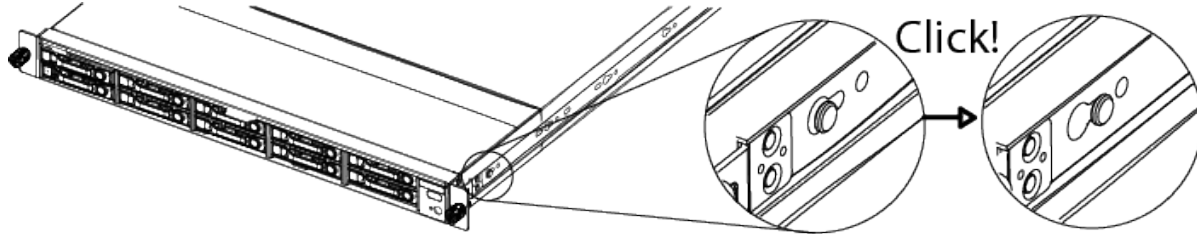

- c. Secure the inner rail to the System Node using one of the screws.
 - d. Repeat these steps to attach the other inner rail.
2. **(1U mounting kit only, skip for 3U mounting kits)** Re-extend the rails on the rack using the levers on the inside of the rails.
3. Align the System Node to the rails attached to the rack.
4. Push the System Node into the rack until it stops. If the System Node uses a 1U mounting kit, the System Node will stop before it is fully seated in the rack.
5. **(1U mounting kit only, skip for 3U mounting kits)** On the sides of the rail, pull the blue tabs to allow the inner rail to slide all the way in.
6. With the System Node inserted fully into the rack, tighten the thumbscrews on the front of the System Node.
7. Replace the drives. For more information, refer to [Installing a System Node drive](#) on page 63.
8. Reconnect all of the cables in the order you removed them.
9. Power on the new System Node.

3.5 Storage Node part replacement instructions

The following sections provide information about Storage Node part replacement.

3.5.1 Replacing 2.5 inch drives



Warning: Ensure that proper ESD equipment is used. If ESD equipment is not used, the replacement drive may be damaged.

Table 3-26. 2.5 inch drive replacement overview

Required tools	Personnel required	Replacement time
None	1	15 to 25 minutes

3.5.1.1 Removing a 2.5 inch drive

To remove a 2.5 inch SSD:

1. If you are replacing a faulty drive, locate the drive and verify that is in the **Decommissioned** state.

Important: The replacement drive must be the same model as the drive that you are replacing. Also, the disk must be completely empty, with no data and no partition table.

Important: If you are removing drives as part of System or Storage Node replacement, skip steps a through f.

- a. On the **ActiveScale SM Dashboard**, click the **Resources** tab.
- b. In the system image on the resources page, click the node with the faulty drive. The node will have an alert icon, and the node status page will appear.
- c. Scroll down the page to the components lists and click the tab for HDDs or SSDs depending on which type of drive has failed.
- d. Look through the list of drives and locate the faulty drive. The status column for the drive will read **Degraded**, **Decommissioning**, or **Decommissioned**.

Note: For more information about drive states, refer to the *ActiveScale OS Administrator Guide*.

- If the status is **Degraded**, the drive has displayed problematic behavior and will undergo automatic repair. If the problematic behavior continues, the drive will be decommissioned.

Important: Do not remove a drive in the **Degraded** state. If the drive returns to the **Online** state, the automatic repairs were successful and no further action is required.

- If the status is **Decommissioning**, the drive is either undergoing automatic repair, or is being prepared for safe removal from the system. When it is safe to remove the drive, the state will change to **Decommissioned**.

Important: Do not remove drives in the **Decommissioning** state. If the drive never reaches the **Decommissioned** state, contact Quantum Corporation support.

- If the status is **Decommissioned**, proceed with physical drive replacement.

- e. Click the **Ident** button to light the front identification LED on the drive.
- f. Identify the physical location of the drive.
2. Press the drive carrier handle release. The handle will pop out.
3. Press the release button on the drive carrier to release the handle.
4. Pull the drive from its slot with even pressure.
5. Record the serial number of the faulty device for return purposes.

Figure 3-41. Removing a drive

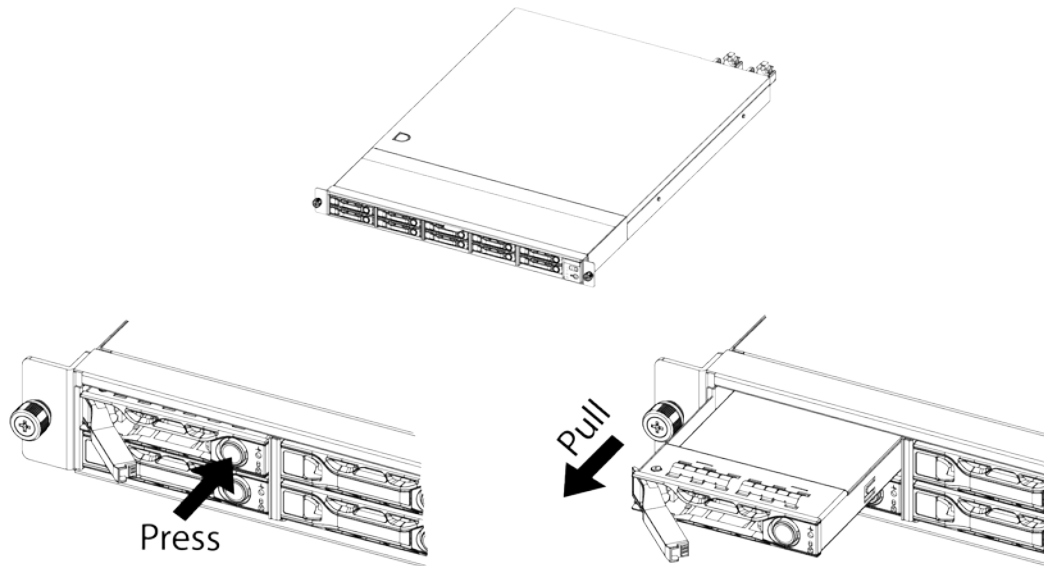

3.5.1.2 Installing a 2.5 inch drive

To install a replacement 2.5 inch drive:

1. Align the replacement drive with the empty slot and slide it into the Storage Node until it stops.
2. Press the retention clip in until there is an audible click.
3. Check to make sure that the drive has been reintegrated and the status is **Online**. If the status is **Degraded**, **Decommissioning**, or **Decommissioned**, wait for approximately 15 minutes and check again.

Important: If the status does not change to **Online**, retry the replacement process or contact Quantum Corporation Support.

3.5.2 Replacing Storage Node PSUs



Caution: Do not touch the Storage Node fan blades. Touching the fan blades can result in injury.

Table 3-27. Storage Node PSU replacement overview

Required tools	Personnel	Replacement time
None	1	5 minutes

3.5.2.1 Removing a Storage Node PSU

To remove a Storage Node PSU:

1. Remove the cord retention clip that holds the power cable in place.
2. Unplug the power cord from the faulty PSU.
3. Grasp the handle pull with even pressure until the unit is removed.
4. Press the release lever in toward the handle to release the PSU from the server.

Figure 3-42. Storage Node PSU handle and latch release

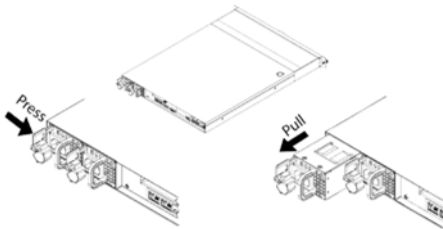

3.5.2.2 Installing a Storage Node PSU

To install a replacement Storage Node PSU:

1. With the handle facing outward, align the replacement PSU with the empty slot.
2. Push the PSU into the server until there is an audible click.
3. Reattach the cord retention clip.
4. Reconnect the power cord.
5. Using UniverStor SM, verify that the PSU is functional.

- In the **UniverStor SM Dashboard**, click the **Resources** tab.
- In the system image on the **Resources** page, click the node with the degraded PSU. The node will have an alert icon. The node's status page will appear.
- Check that all of the PSU Icons listed under the PSU section do not have alert notifications.

Figure 3-43. PSU failure (left) and online PSU (right) icons



3.5.3 Replacing SFP+ 10G transceivers

Required tools	Personnel	Replacement time
None	1	~4 min

Note: The replacement procedure in this section applies to both sets of SFP+ transceivers.

3.5.3.1 Removing an SFP+ 10G transceiver

To replace the Storage Node SFP+ transceiver:

- From the rear of the rack, remove both of the fiber optic cables from the failed SFP+ transceiver.
- Open the SFP+ transceiver latch.
- Remove the SFP+ transceiver from the System Node.

Figure 3-44. SFP+ transceiver removal

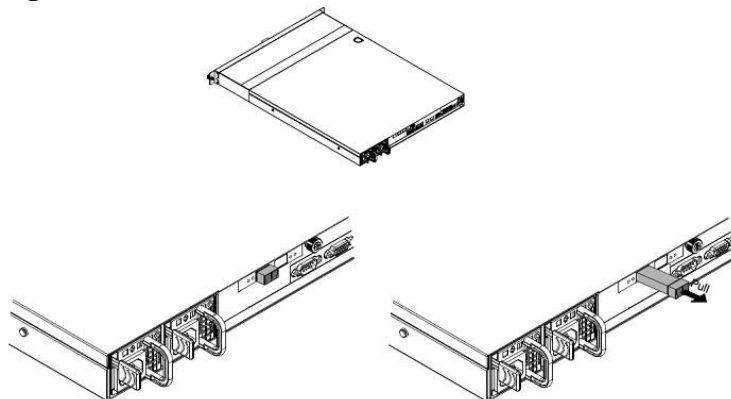

3.5.3.2 Installing an SFP+ transceiver

To install a replacement SFP+ transceiver:

1. Open the latch on the SFP+ transceiver.
2. From the rear of rack, with the label facing down, insert the SFP+ transceiver into the SFP+ port.
3. Close the latch on the SFP+ transceiver.

3.5.4 Replacing Storage Nodes



Caution: Ensure that the power cables are not damaged. If they are damaged, they may be a shock hazard and the system may need to be shutdown to replace the Storage Node.



Warning: Use caution when lifting. The Storage Node weighs 27 lbs (12.2 kg).



Caution: Electrostatic discharge can harm the delicate components inside Quantum Corporation products.



Caution: Disconnect all power sources before servicing.

Table 3-28. Storage Node replacement overview

Required Tools	Personnel	Replacement Time
#2 Phillips-Head Screwdriver	1	~15 min

3.5.4.1 Removing a Storage Node

To remove a Storage Node:

Tip: Before you begin, check that the cables are labeled properly. This ensures that the Storage Node can be reconnected in the same order.

1. Shut down the node. If the node is already shut down (for example, because it has failed), skip this step.

Important: Do not shut down a node unless all other nodes are healthy.

Figure 3-45. Resources > Rack > Node > Shutdown

er: r00001 Hardware Failures:

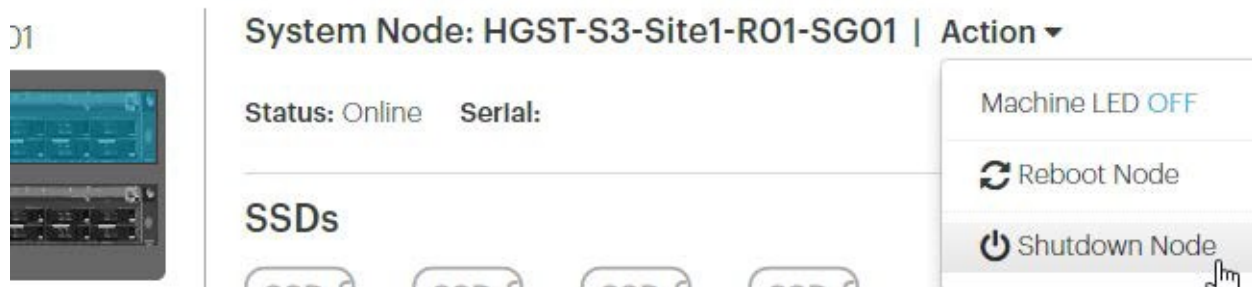

- Click **Resources**.
- On multi-site systems, select a site from the **Sites** pull-down menu.
- In the **Racks** pull-down menu, select a system.
- In the rack graphic, select the node you want to shut down. Typically, the node you want to shut down has a failure icon overlay.
- In the node's **Actions** pull-down menu, select **Shutdown Node**.
- A pop-up appears asking you to confirm that all other nodes in the system are healthy. If so, type the password for `admin` and click **Shutdown**

Figure 3-46. Admin Password.

- Wait for UniverStor SM to display a notification in a green banner indicating that the node was shut down successfully:

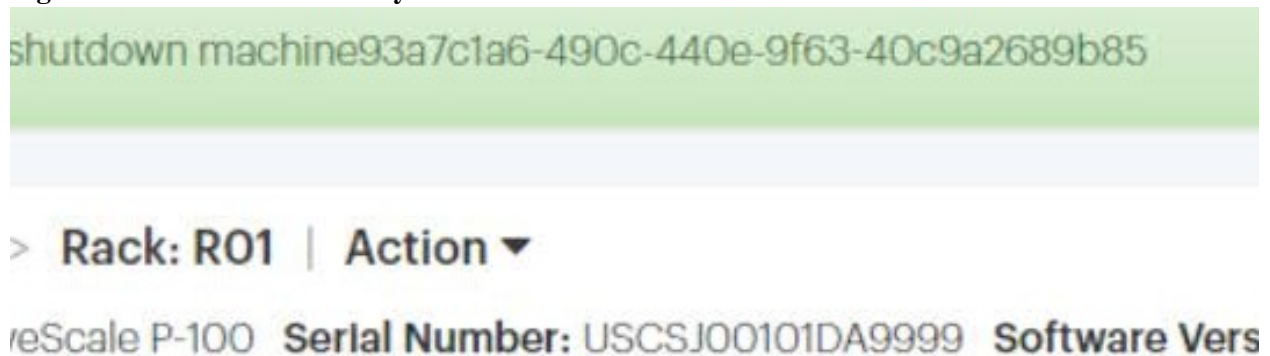
Figure 3-47. Node successfully shut down banner

- Confirm that you shut down the right node by checking that its front and back LEDs are off.

2. Disconnect the cables from the faulty Storage Node.
3. Remove the drives from the front of the faulty Storage Node. For more information, refer to [Removing a 2.5 inch drive](#) on page 70.

Important: Place the drives in a secure, ESD safe location. Make note of the order the drives in the order they were removed from the Storage Node in. This will help you reinstall them in the correct order.

4. Unscrew the thumb screws located on the front of the Storage Node.
5. Grasp the Storage Node and pull with even pressure until the system will not extend further.
6. Unlatch the Storage Node from the rack.
 - a. Locate the safety latch release lever on the side of the Storage Node as shown in the following image.

Figure 3-48. Latch Release Levers

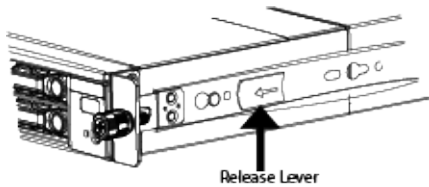

- b. Press the latch release levers toward the front of the Storage Node. The Storage Node is now free from the rack and can be fully removed.
7. Carefully remove the Storage Node from the system.

Caution: For safety, push the rails that are extending out of the front of the rack back into the rack.

8. Record the serial number for return purposes. The serial number and part number are located on a pull-out tab located on the front of the Storage Node.

3.5.4.2 Installing a Storage Node

To install the replacement Storage Node:

1. Remove the rails attached to the faulty Storage Node and attach them to the replacement node.
 - a. Unscrew the two screws that attach the rails to the Storage Node.

Figure 3-49. Storage Node inner rail removal

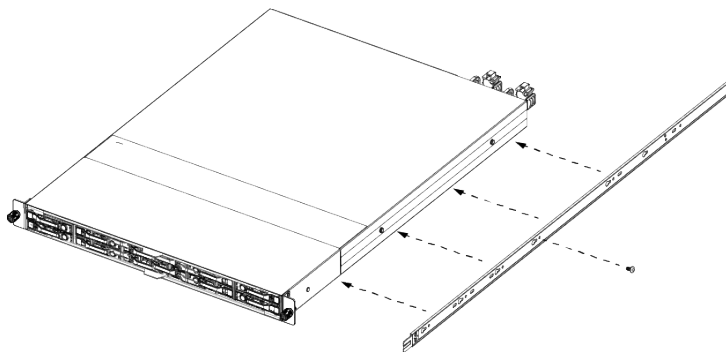

- b. Attach the rails to the replacement Storage Node.
2. Align the rails on the replacement Storage Node with the rack rails.
3. Push the Storage Node into the rack.
4. Tighten the thumb screws on the front of the Storage Node.
5. Replace the drives in the same order that they were removed in. For more information, refer to [Installing a 2.5 inch drive](#) on page 71.
6. Reconnect the cables in the back of the Storage Node in the original configuration listed in [System cabling](#) on page 117.
7. Power on the Storage Node using the power button on the front panel.
8. If Quantum Corporation support is not onsite, contact customer support for the final post-replacement procedures for bringing the Storage Node online.

3.6 Storage Enclosure Basic part replacement instructions

The following sections provide information about Storage Enclosure Basic part replacement.

3.6.1 Replacing Storage Enclosure Basic I/O modules



Caution: Disconnect all power sources before servicing.

Table 3-29. I/O module replacement overview

Required Tools	Personnel	Replacement Time
None	1	3 min

Warning: The I/O module is bottom-heavy. Support the I/O module from the bottom during replacement.

3.6.1.1 Removing a Storage Enclosure Basic I/O module

To remove a Storage Enclosure Basic I/O module:

1. Shut off reads and writes to the Storage Enclosure Basic by powering down the associated Storage Node.

Important: Do not shut down a node unless all other nodes are healthy.

Figure 3-50. Resources > Rack > Node > Shutdown

er: r00001 Hardware Failures:

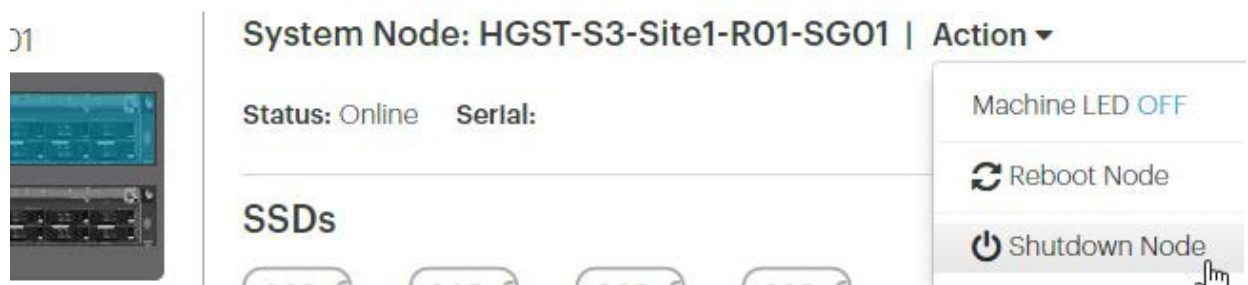

- a. Click **Resources**.
- b. On multi-site systems, select a site from the **Sites** pull-down menu.
- c. In the **Racks** pull-down menu, select a system.
- d. In the rack graphic, select the node you want to shut down. Typically, the node you want to shut down has a failure icon overlay.
- e. In the node's **Actions** pull-down menu, select **Shutdown Node**.
- f. A pop-up appears asking you to confirm that all other nodes in the system are healthy. If so, type the password for `admin` and click **Shutdown**

Figure 3-51. Admin Password.



Do not shutdown this node unless all other servers are up and running normally. Are you sure you want to continue?

ber Password

Onl

Cancel Shut Down

- g. Wait for UniverStor SM to display a notification in a green banner indicating that the node was shut down successfully:

Figure 3-52. Node successfully shut down banner

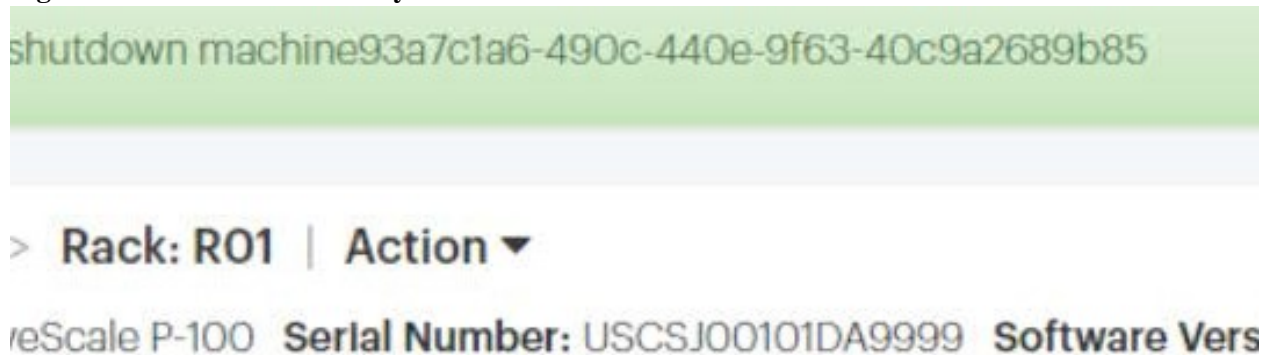

- h. Confirm that you shut down the right node by checking that its front and back LEDs are off.

2. Lift the power cord retention bale.
3. Unplug both power cables.

Figure 3-53. Removing the power cables (power cables shown in red)

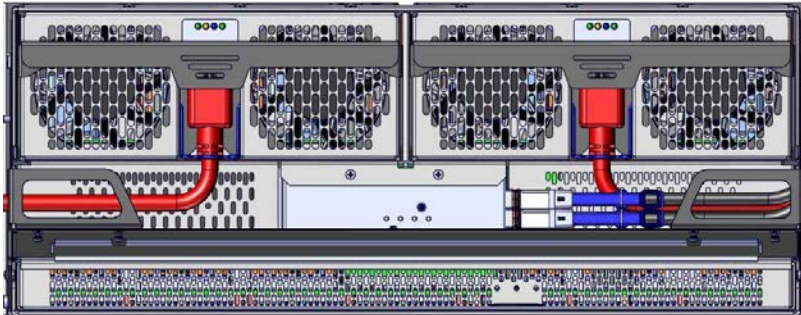

4. Pull the release tab and unplug the miniSAS cables.

Figure 3-54. Removing the miniSAS cables (miniSAS cables shown in red)

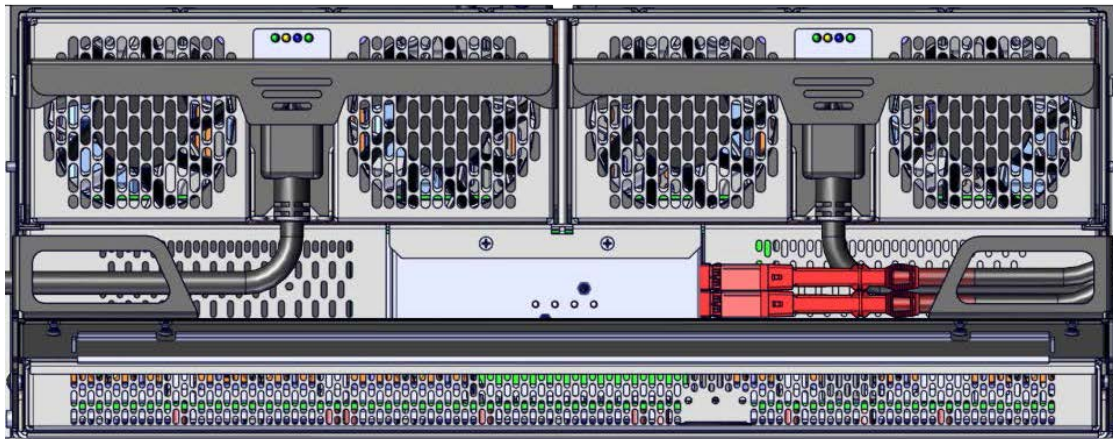

Tip: Take note of which port miniSAS cable came from which port to ensure that they are plugged in correctly when reassembling.

5. While supporting the I/O module from the bottom, pull the latch handle towards you.

Warning: The I/O module is bottom-heavy. Continue supporting the module from the bottom during the rest of the removal procedure.

Figure 3-55. Unlocking the I/O module

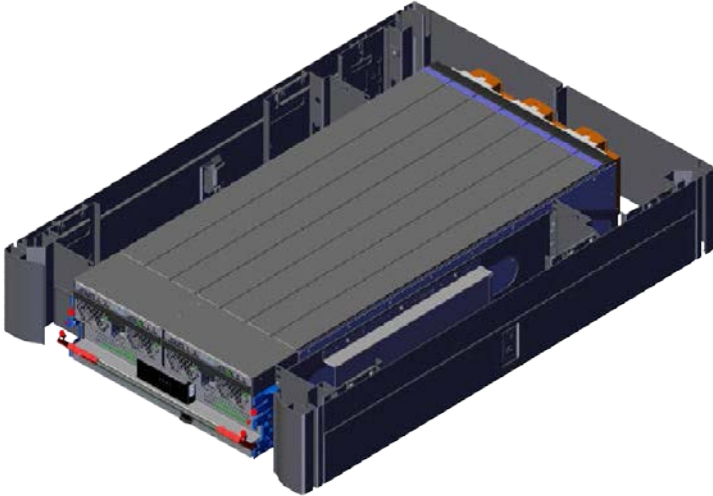

6. Remove the I/O module from the chassis.

Figure 3-56. Removing the I/O module

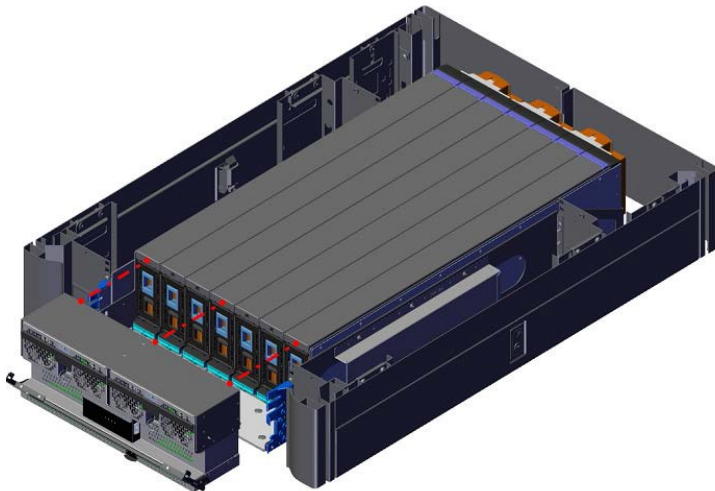

3.6.1.2 Installing a Storage Enclosure Basic I/O module

To install a replacement I/O module:

1. Set the I/O module half-way into the Storage Enclosure Basic chassis with the handle still unlocked.

Figure 3-57. Sliding the I/O module into the chassis

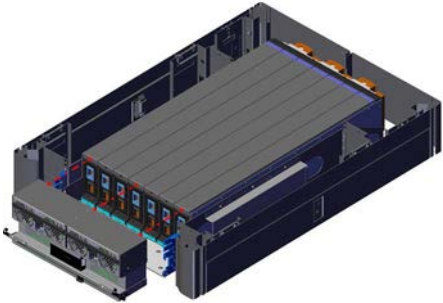

2. Plug the HD miniSAS cables into the HD miniSAS ports.
3. Route the power cords through the I/O module handle.

Important: Do not plug in the PSUs until the I/O module is fully seated.

4. Push the I/O module into the chassis until seated against the sleds.
5. Lock the I/O module handle by pushing rotating the I/O module handle up.

Figure 3-58. Locking the I/O module

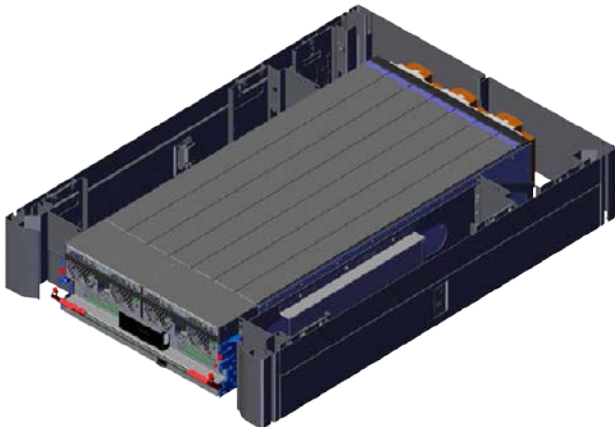

6. Plug the power cords into the power cord ports at the bottom of each power supply unit. The Storage Enclosure basic will power on automatically.
7. In ActiveScale SM, verify that sled installation succeeded.
 - a. In ActiveScale SM, click **Resources**.
 - b. In the system graphic, select the correct Storage Node and confirm that its status is **ONLINE**.
 - c. In the system graphic, select the correct Storage Enclosure Basic and confirm that:
 - Its status is **ONLINE**
 - The correct number and position of installed sled(s) is shown
 - Disks in the newly installed sled(s) have the status **NOTMANAGED**

3.6.2 Replacing Storage Enclosure Basic sleds or sled blanks



Caution: Disconnect all power sources before servicing.

Table 3-30. Sled and sled blank replacement overview

Required tools	Personnel	Replacement time
#2 Phillips head screwdriver	1	8 min

Important: Install the replacement sleds in the same slots as the failed sleds. Remove and install sleds in the same order.

3.6.2.1 Sled replacement constraints

When replacing sleds or sled blanks, the following constraints apply:

- Each slot must contain either a populated sled or a sled blank.
- Each Storage Enclosure Basic must have the same configuration of populated sleds and sled blanks.
- Each sled must be fully populated with 14 drives.
- Populated sleds must be inserted contiguously on the left side of the Storage Enclosure Basic. There can not be any sled blanks between populated sleds.
- Populated sleds must be added to Storage Enclosure Basics in one column increments. ActiveScale X100 systems are scaled up in increments of six sleds.
- Sled blanks cannot be populated with drives. You must order a new sled with drives.

3.6.2.2 Removing a Storage Enclosure Basic sled or sled blank

To replace a Storage Enclosure Basic sled or sled blank:

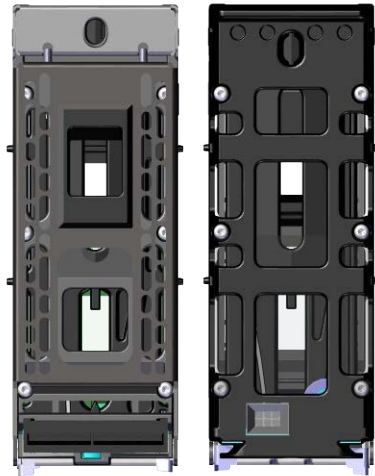
Figure 3-59. Front and rear view of a sled

Warning: To prevent damage to sled components and connectors do not put any weight on either end of the sleds or stand sleds on either end.

Note: If a sled blank is physically damaged, ActiveScale SM might not indicate that the sled blank is faulty.

1. Shut off reads and writes to the Storage Enclosure Basic by powering down the associated Storage Node.

Important: Do not shut down a node unless all other nodes are healthy.

Figure 3-60. Resources > Rack > Node > Shutdown

er: r00001 Hardware Failures:

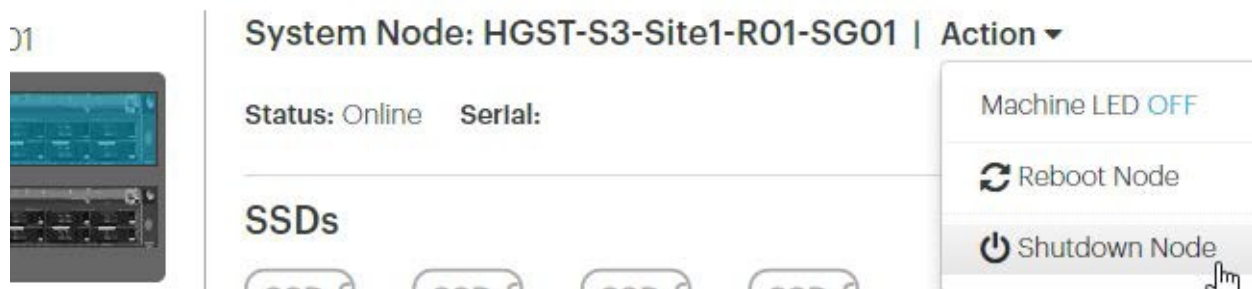

- a. Click **Resources**.
- b. On multi-site systems, select a site from the **Sites** pull-down menu.
- c. In the **Racks** pull-down menu, select a system.
- d. In the rack graphic, select the node you want to shut down. Typically, the node you want to shut down has a failure icon overlay.
- e. In the node's **Actions** pull-down menu, select **Shutdown Node**.

- f. A pop-up appears asking you to confirm that all other nodes in the system are healthy. If so, type the password for admin and click **Shutdown**

Figure 3-61. Admin Password.

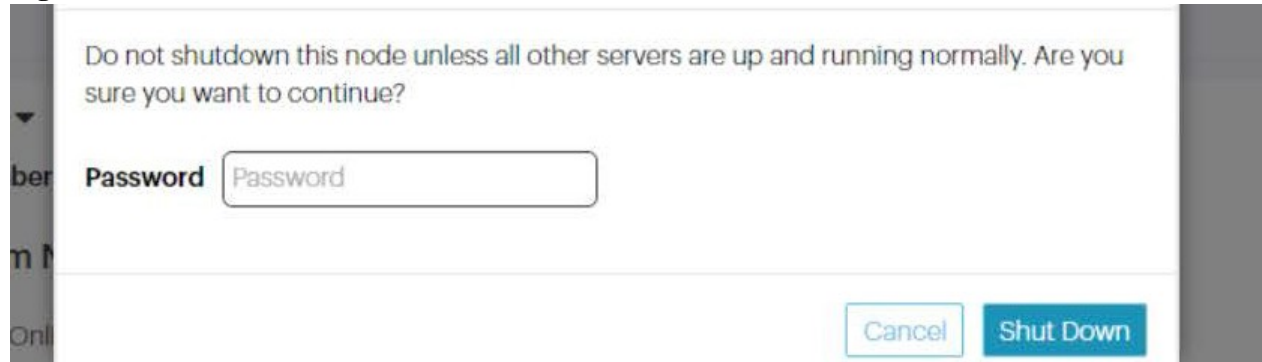

- g. Wait for UniverStor SM to display a notification in a green banner indicating that the node was shut down successfully:

Figure 3-62. Node successfully shut down banner

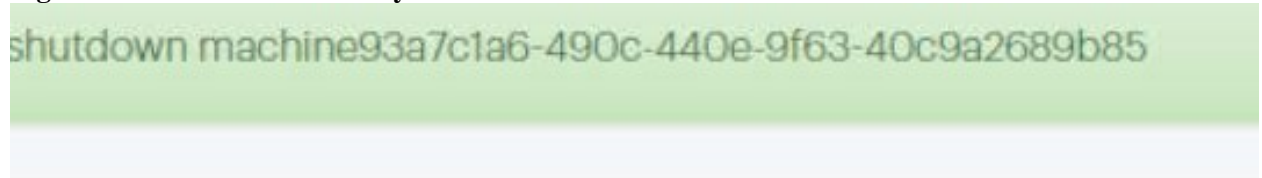

> Rack: R01 | Action ▼

reScale P-100 Serial Number: USCSJ00101DA9999 Software Vers

- h. Confirm that you shut down the right node by checking that its front and back LEDs are off.

 1. Remove the I/O module. For more information, refer to [Removing a Storage Enclosure Basic I/O module](#) on page 77.
 2. On the front of the sled or sled blank, press the latch mechanism button and pull it until it is at a 45° angle.

Figure 3-63. Release button

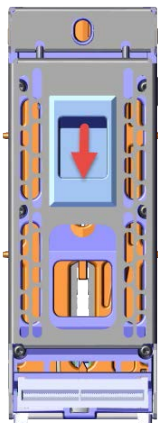

3. Pull the failed sled or sled blank out of the chassis.

Figure 3-64. Removing a sled

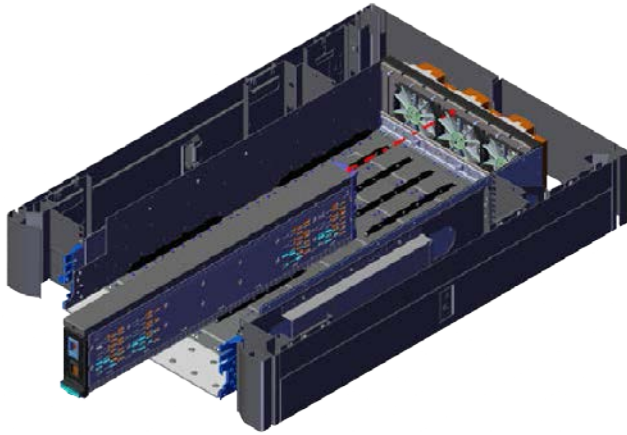

3.6.2.3 Installing a sled or sled blank

To install a replacement sled or sled blank:

1. Line up the replacement sled or sled blank in the chassis.
2. Rest the sled or sled blank on the front of the chassis so it is level.

Important: Do not tip the sled up or down to insert it.

Note: The sled can be inserted with the latch open or closed.

Figure 3-65. Seated sled

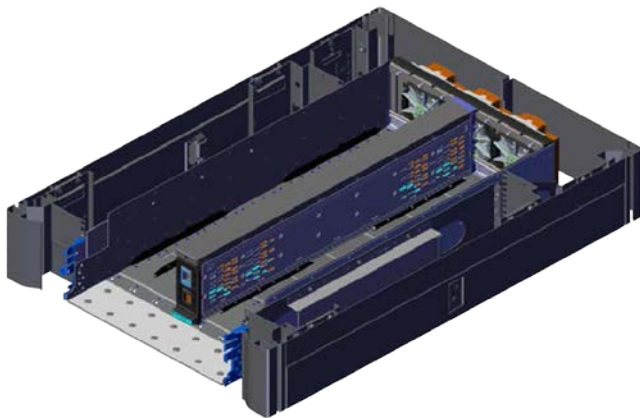

3. Replace the I/O chassis and reattach the cables. For more information, refer to [Installing a Storage Enclosure Basic I/O module](#) on page 80.
4. Power the Storage Node back on using the Node's front power button.
5. Using ActiveScale SM, verify that:
 - The Storage Node is online and linked to the Storage Enclosure.
 - The Storage Enclosure has no errors.

3.6.3 Replacing Storage Enclosure Basic fans



Warning: Do not touch the fan blades. Touching the fan blades can result in injury.

Table 3-31. Storage Enclosure Basic fan replacement overview

Required tools	Personnel	Replacement time
None	1	3 min

Warning: Replace rear fans quickly. If a failed fan is removed for prolonged periods of time, the risk of overheating is elevated. To prevent a back flow of hot air, Quantum Corporation recommends leaving the failed fan in place until you are ready to install a replacement.

3.6.3.1 Removing a Storage Enclosure Basic fan

To remove a fan:

1. From the rear of the chassis, press the release button on the top right of the fan.
2. Using a moderate amount of force, tilt the top of the fan out until clear of the rubber bumpers attached to the chassis.

Figure 3-66. Rear fan

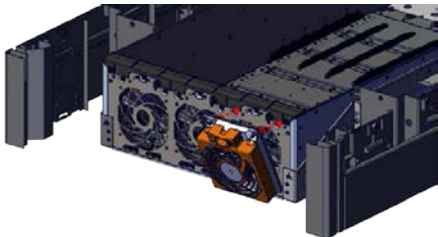

3.6.3.2 Installing a Storage Enclosure Basic fan

To install a replacement fan:

1. From the rear of the chassis, line the up the bottom of the fan with the rubber bumpers on the chassis.
2. Tilt the top of the fan until the fan pins line up with the connectors on the chassis.

Warning: To prevent damage to the rear fan components, press the at the top of the fan. Do not push on the fan spokes or place the fan with the pins and connector facing down during installation.

3. Press firmly until the fan is securely locked into place.
4. Verify that the fan LED has no faults.

3.6.4 Replacing Storage Enclosure Basic PSUs



Caution: Disconnect all power sources before servicing.

Table 3-32. Storage Enclosure Basic PSU replacement overview

Required tools	Personnel	Replacement time
None	1	8 min

3.6.4.1 Removing a Storage Enclosure Basic PSUs

To remove a Storage Enclosure Basic PSU:

1. Lift the cord retention bale.
2. Unplug the power cord from the PSU.

Figure 3-67. Removing the power cables (power cables shown in red)

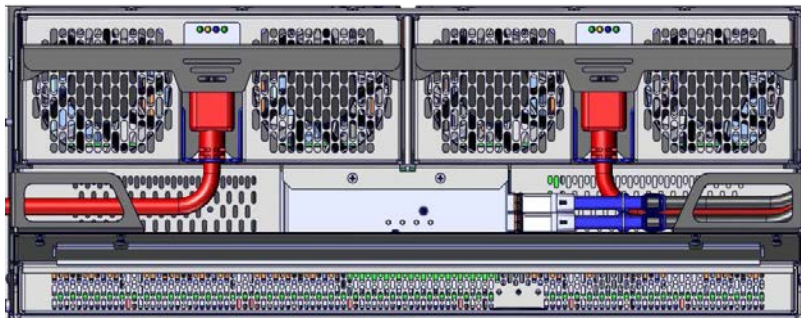

3. Pull the latch handle out and away from the I/O module. The latch handle should be at a 45° angle when the PSU is removed.
4. Pull the PSU free of the I/O module.

Figure 3-68. Removing the PSU

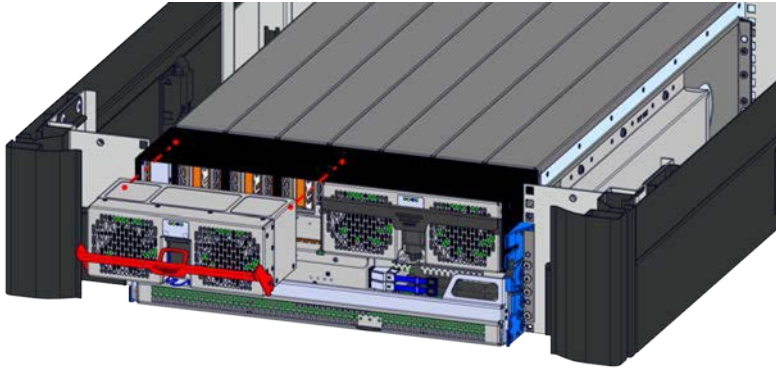

3.6.4.2 Installing a Storage Enclosure Basic PSU

To install a replacement Storage Enclosure Basic PSU:

1. Slide the PSU into the I/O module.
2. Plug the power cord back into the replacement PSU.
3. Once the PSU is powered up, verify that the PSU is functional using the onboard LEDs.

Note: Two of the four LEDs should be green to show proper operation. The two green LEDs are located on the right. It is normal for the far right LED to have some delay in lighting up after the power cord is plugged in.

4. Using UniverStor SM, verify that the PSU is functional.
 - a. In the **UniverStor SM Dashboard**, click the **Resources** tab.
 - b. In the system image on the **Resources** page, click the node with the degraded PSU. The node will have an alert icon. The node's status page will appear.
 - c. Check that all of the PSU Icons listed under the PSU section do not have alert notifications.

Figure 3-69. PSU failure (left) and online PSU (right) icons



3.6.5 Replacing Storage Enclosure Basic hard disk drives

Important: Contact Quantum Corporation support before replacing a Storage Enclosure Basic hard disk drive.



Caution: Ensure that proper ESD equipment is used. If ESD equipment is not used, the replacement drive may be damaged.



Caution: Disconnect all power sources before servicing.

Table 3-33. Storage Enclosure Basic hard disk drive replacement overview

Required tools	Personnel	Replacement time
#2 Phillips head Screwdriver	1	8 min

Important: The replacement of the drive should be completed within 20 minutes of removing AC power from the system. Once power is removed from the system, the indicator LEDs will stay lit for a maximum of 20 minutes.

3.6.5.1 Removing a Storage Enclosure Basic hard disk drive

To remove a Storage Enclosure Basic hard disk drive:

1. Shut off reads and writes to the Storage Enclosure Basic by powering down the associated Storage Node.

Important: Do not shut down a node unless all other nodes are healthy.

Figure 3-70. Resources > Rack > Node > Shutdown

er: r00001 Hardware Failures:

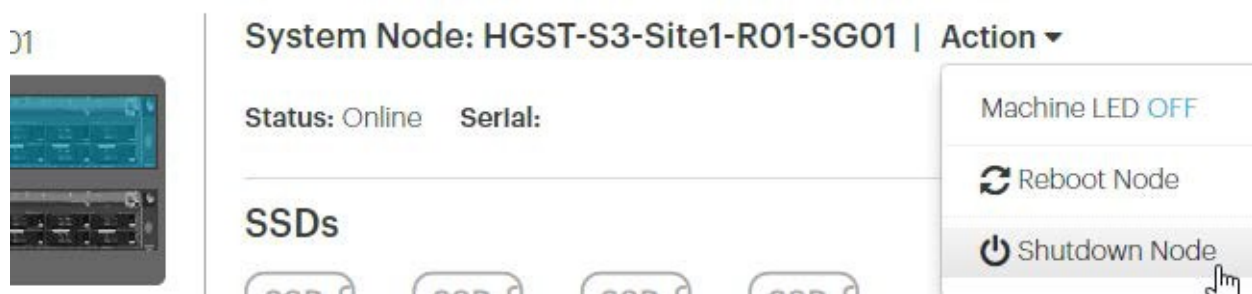

- a. Click **Resources**.
- b. On multi-site systems, select a site from the **Sites** pull-down menu.
- c. In the **Racks** pull-down menu, select a system.
- d. In the rack graphic, select the node you want to shut down. Typically, the node you want to shut down has a failure icon overlay.
- e. In the node's **Actions** pull-down menu, select **Shutdown Node**.

- f. A pop-up appears asking you to confirm that all other nodes in the system are healthy. If so, type the password for admin and click **Shutdown**

Figure 3-71. Admin Password.



- g. Wait for UniverStor SM to display a notification in a green banner indicating that the node was shut down successfully:

Figure 3-72. Node successfully shut down banner

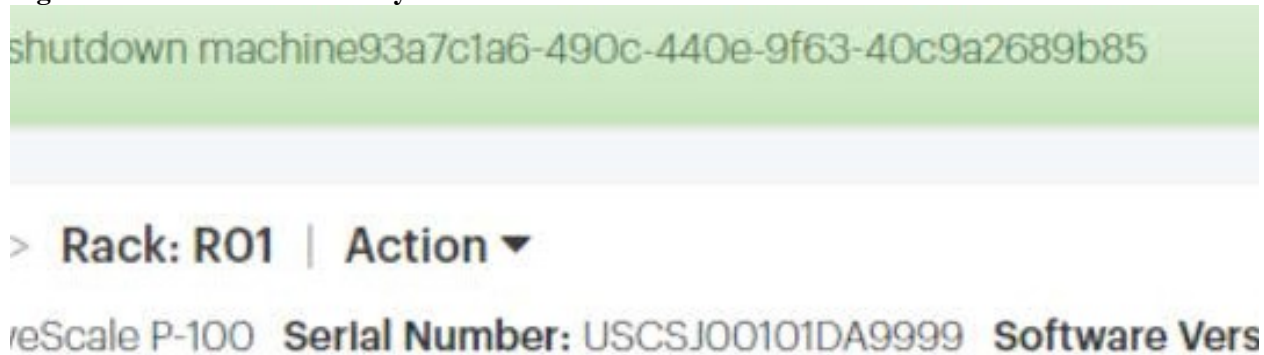

- h. Confirm that you shut down the right node by checking that its front and back LEDs are off.

1. Remove the I/O module. For more information, refer to [Replacing Storage Enclosure Basic I/O modules](#) on page 77.
2. Locate the sled with the flashing **Ident** LED.

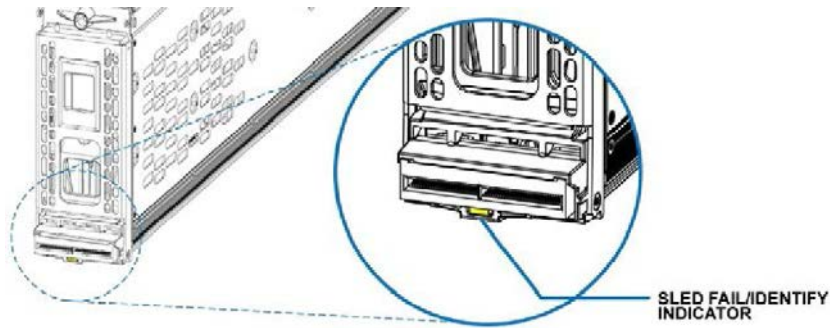

3. Remove the sled. For more information, refer to [Removing a Storage Enclosure Basic sled or sled blank](#) on page 82.
4. After removing the sled, push the drive cover back and up until it has been removed.

Figure 3-73. Sled cover

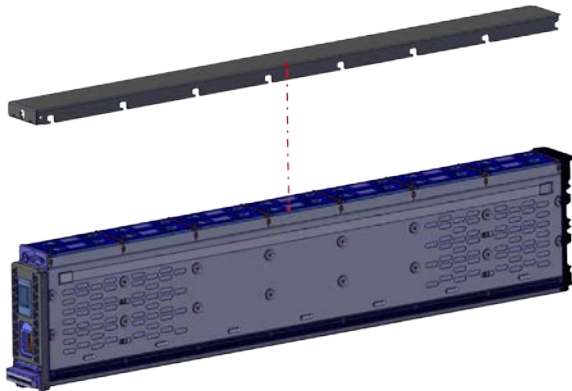

5. Locate the flashing hard disk drive **Ident** LED.

Figure 3-74. HDD Ident LED



6. Press the two buttons on the hard drive carrier.
7. Remove the drive.

Figure 3-75. HDD buttons

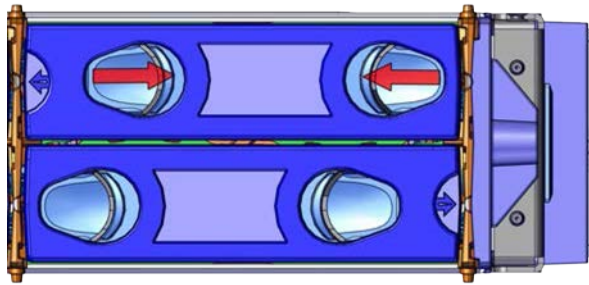
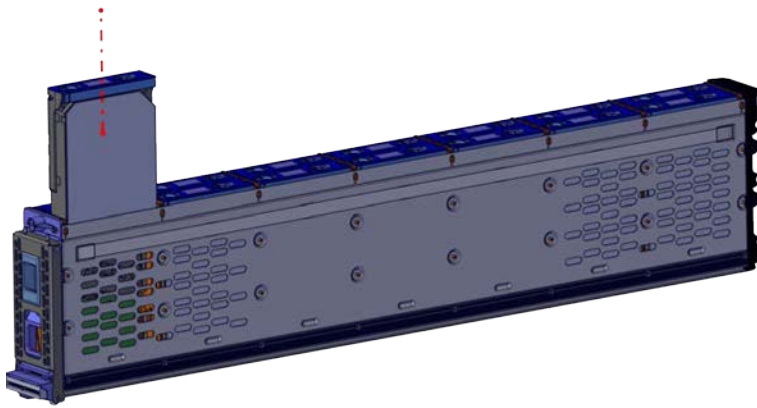

Figure 3-76. Removing a hard disk drive



Note: If the supercap discharges and can no longer power the LEDs, the LED state will be saved in non-volatile memory so that when the enclosure is booted, the administrator will still be able to identify the enclosure and component in question.

3.6.5.2 Installing a Storage Enclosure Basic hard disk drive

To install a replacement HDD:

1. Install the replacement drive and its new carrier.
2. Replace the sled cover.
3. Reinstall the sled. For more information, refer to [Installing a sled or sled blank](#) on page 85.
4. Replace and reconnect the I/O module. For more information, refer to [Installing a Storage Enclosure Basic I/O module](#) on page 80.
5. Power on the Storage Node using the front power button.
6. Using ActiveScale SM, verify that:
 - The Storage Node is online and linked to the Storage Enclosure.
 - The new sled drive appears and displays as functional.

3.6.6 Replacing a Storage Enclosure Basic chassis



Warning: The chassis is heavy and awkward. Grasp the chassis securely when handling. Due to the size and weight of the chassis, Quantum Corporation recommends using two people to lift and install the chassis



Caution: Disconnect all power sources before servicing.

Table 3-34. Storage Enclosure Basic chassis replacement overview

Required tools	Personnel	Replacement time
<ul style="list-style-type: none"> • #2 Phillips-Head Screwdriver with torque measuring capabilities • T10 Screwdriver with torque measuring capabilities • Level 	1. However, 2 are recommended.	40 min

3.6.6.1 Removing a Storage Enclosure Basic chassis

To remove the Storage Enclosure Basic chassis:

1. Shut off reads and writes to the Storage Enclosure Basic by powering down the associated Storage Node.

Important: Do not shut down a node unless all other nodes are healthy.

Figure 3-77. Resources > Rack > Node > Shutdown

er: r00001 Hardware Failures:

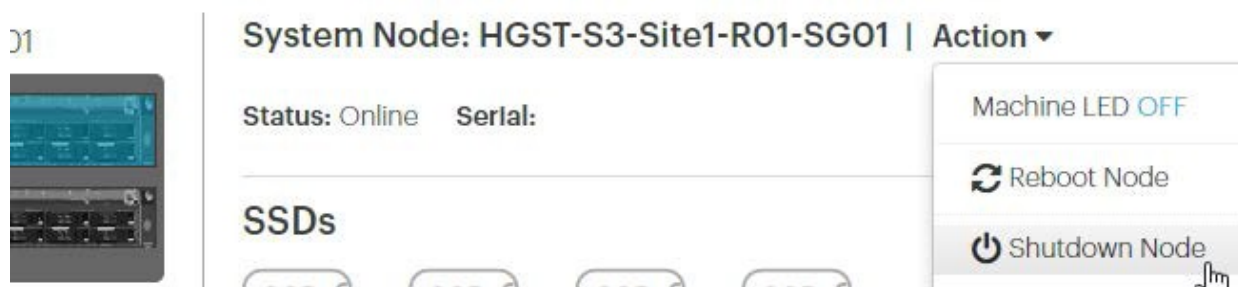

- a. Click **Resources**.
- b. On multi-site systems, select a site from the **Sites** pull-down menu.
- c. In the **Racks** pull-down menu, select a system.
- d. In the rack graphic, select the node you want to shut down. Typically, the node you want to shut down has a failure icon overlay.
- e. In the node's **Actions** pull-down menu, select **Shutdown Node**.
- f. A pop-up appears asking you to confirm that all other nodes in the system are healthy. If so, type the password for `admin` and click **Shutdown**

Figure 3-78. Admin Password.

Do not shutdown this node unless all other servers are up and running normally. Are you sure you want to continue?

ber Password

Onl

- g. Wait for UniverStor SM to display a notification in a green banner indicating that the node was shut down successfully:

Figure 3-79. Node successfully shut down banner

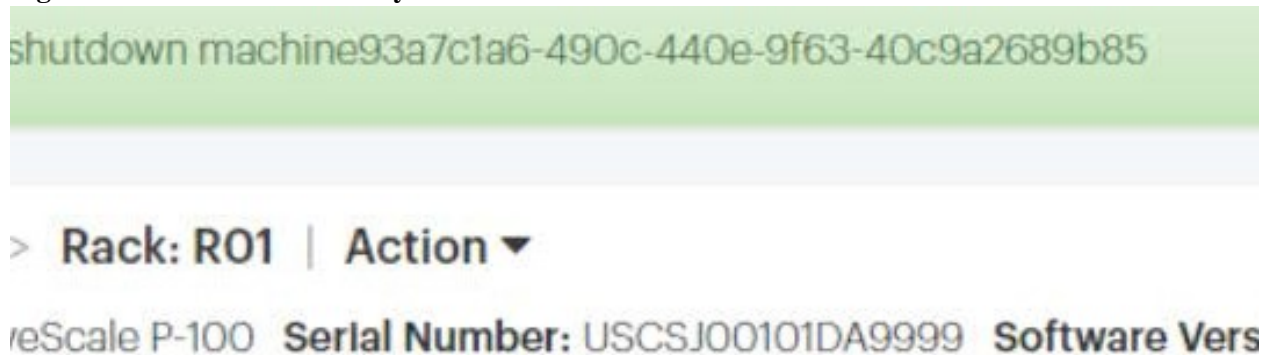

- h. Confirm that you shut down the right node by checking that its front and back LEDs are off.

2. Remove the I/O module. For more information, refer to [Replacing Storage Enclosure Basic I/O modules](#) on page 77.
3. Remove the sleds and sled blanks. For more information, refer to [Replacing Storage Enclosure Basic sleds or sled blanks](#) on page 82.
4. Remove the rear fans. For more information, refer to [Replacing Storage Enclosure Basic fans](#) on page 86.
5. From the inside of the chassis, remove the sidewall Torx screws that secure the chassis to the rail kit. Each side contains three screws.

Figure 3-80. Chassis sidewall screws

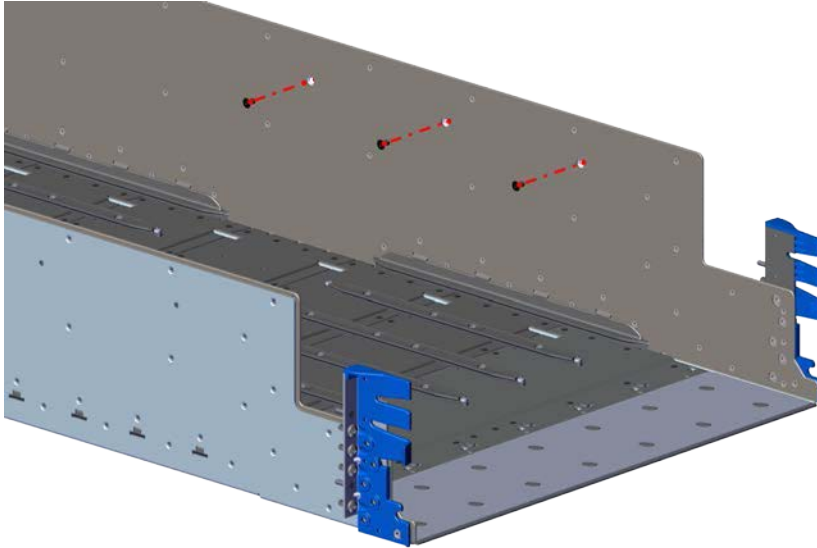

6. From the front of the rack, remove the Phillips screws that hold the rack ears to the front vertical rail.
7. From the inside front of the chassis, remove the rack ear Torx screws. Each rack ear contains five screws.
8. Remove the four screws that connect the chassis to the rack.

Figure 3-81. Rear chassis screws

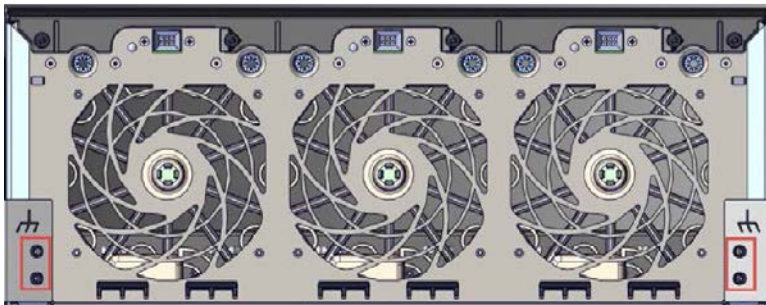

9. From the front of the chassis, pull the chassis out and away from the rail kit.

Figure 3-82. Removing the chassis

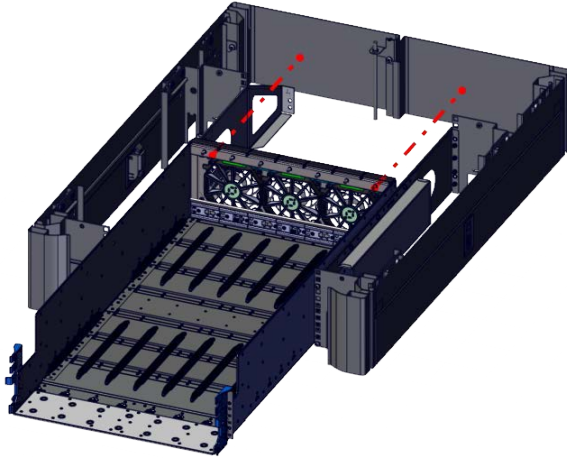

3.6.6.2 Installing a Storage Enclosure Basic chassis

To install a Storage Enclosure Basic chassis:

1. Attach each of the rack ears to the front outside of the of the chassis with five, M4 x 8 Torx screws.

Important: Only tighten the screws until they reach the blue locktight on the threads.

Figure 3-83. Rack ears

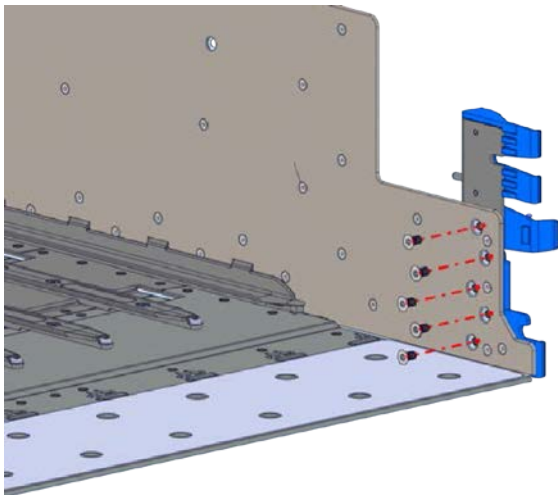

2. Lift the chassis and place it on the mounting rails.
3. Slide the chassis into the rack until the chassis is fully inserted in the rack.

Figure 3-84. Chassis

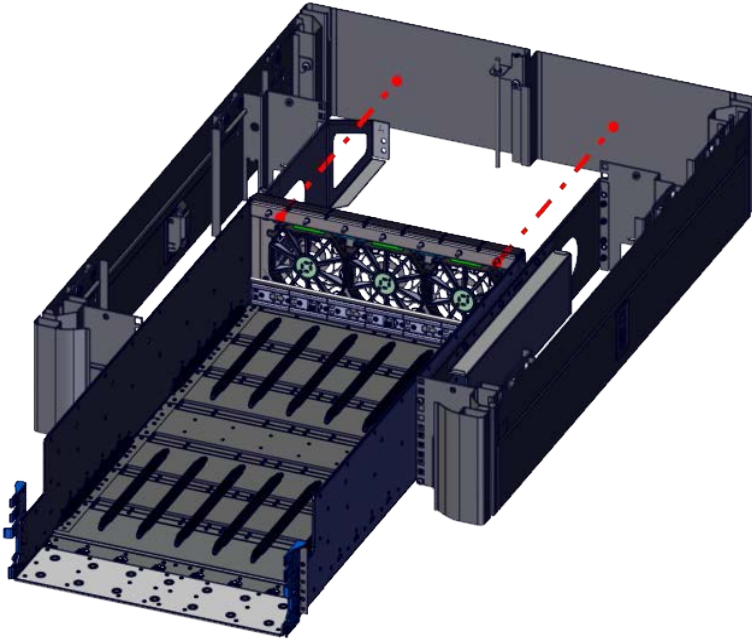

4. From the inside of the chassis, secure the sides of the chassis to the rails using three, M4 x 8 screws. Each side should contain three screws in the sidewall of the chassis.

Figure 3-85. Chassis sidewall screws

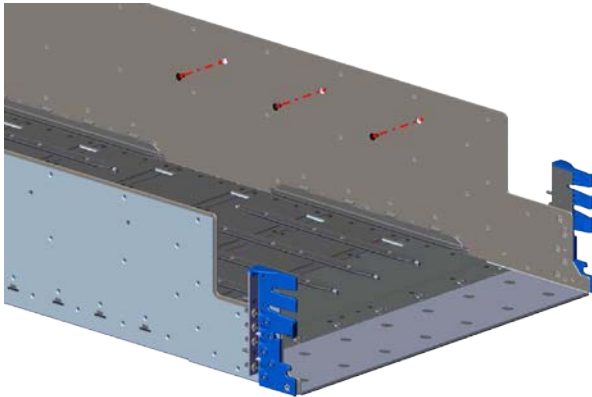

5. Repeat the previous step to secure the other side of the chassis to the rails.
6. After the inside screws are in place, tighten all six screws completely.
7. Fully tighten the five rack ear screws on each side of the chassis.
8. From the front of the rack, attach the rack ear to the front rack mount rail with four, M5 x 12 screws.

Important: Leave the screws loose.

Figure 3-86. Front rack ears and rack mount rail screw configuration

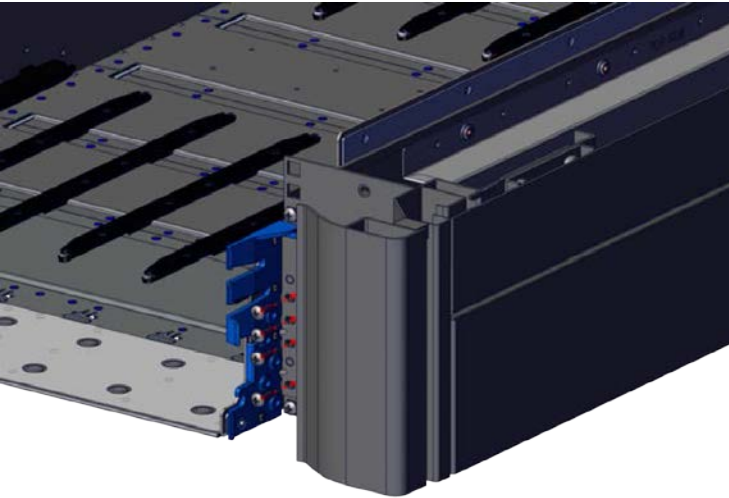

9. Follow the previous steps to attach the other rack ear and rack mount rail.
10. On the left side of the rack, push the edge of the chassis to the left until it is flush with, or just slightly to the left of, the front face of the vertical rail.

Figure 3-87. Chassis Alignment Reference

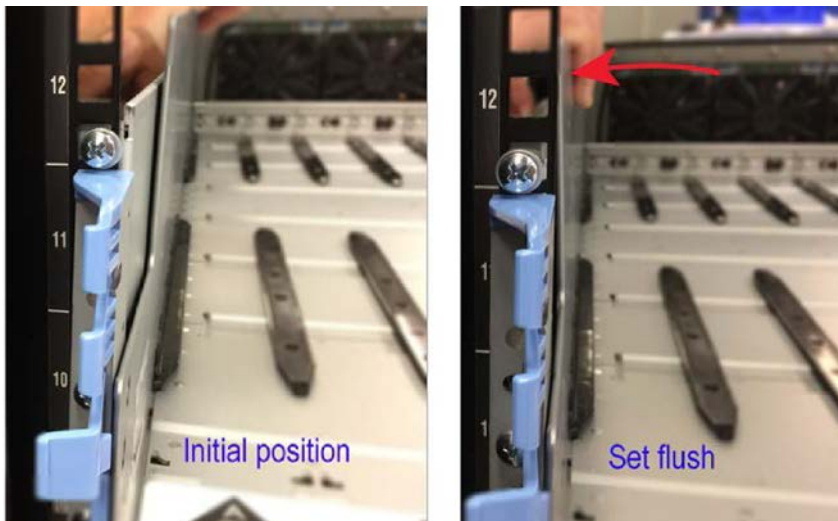

11. While ensuring that the position of the chassis does not move, secure the four screws of the chassis to the vertical rail. Fully tighten the screws (see [Recommended torque of machined fasteners](#) on page 238).
12. On the right side of the rack, push the edge of the chassis to the right until it is flush with, or just slightly to the right of, the front face of the vertical rail.
13. While ensuring that the position of the chassis does not move, secure the four screws of the chassis to the vertical rail. Fully tighten the screws.
14. From the back of the rack, fully tighten the four rail screws on the left side of the rack, and then fully tighten the four rail screws on the right side of the rack.

3.7 Rack part replacement instructions

The following sections provide information about rack and mounting kit part replacement.

3.7.1 Replacing the Management Interconnect mounting kit (racked systems)



Warning: Some components are heavy.



Caution: Disconnect all power sources before servicing.

Table 3-35. Management Interconnect mounting kit replacement overview

Required Tools	Personnel	Replacement Time
#2 Phillips head Screwdriver with torque measuring capabilities.	1	15 min

Important: This procedure only applies to racked ActiveScale X100 systems. If you need replacement rack adapters for a rackless ActiveScale X100 system, contact Quantum Corporation support.

3.7.1.1 Removing a Management Interconnect mounting kit

To remove a Management Interconnect mounting kit:

1. Remove the Management Interconnect tray from the rack. For more information, refer to [Removing the Management Interconnect from a racked system](#) on page 51.
2. From the rear of the rack, remove the screws that attach the rack mount rails to the rack.
3. Remove the rack rails.
4. Remove the three screws that attach the inner rails to the Management Interconnect tray.
5. Remove the inner rails from the Management Interconnect tray.

Figure 3-88. Screws on Management Interconnect tray rail



3.7.1.2 Installing a Management Interconnect mounting kit

To install a replacement Management Interconnect mounting kit:

1. Attach the new rack mount rails to the rack using the screws that were removed from the original rail kit.
2. Attach the new inner rails to the Management Interconnect tray, and fasten the three screws securely.
3. Insert the Management Interconnect tray back into the rack. For more information, refer to [Replacing Management Interconnects \(racked system\)](#) on page 51.

3.7.2 Replacing the 1U mounting kit for System and Storage Nodes



Warning: Some components are heavy.



Caution: Disconnect all power sources before servicing.

Table 3-36. 1U mounting kit replacement overview

Required tools	Personnel	Replacement time
#2 Phillips head Screwdriver	1	15 min

3.7.2.1 Removing a 1U mounting kit

To remove a 1U mounting kit from a System or Storage Node:

Tip: From the rear of the system, check that the cables are labeled properly so you can reconnect them in the same order.

1. At the back of the system, disconnect all of the cables.

Warning: Ensure that the power cables are not damaged. If they are damaged, they may be a shock hazard and the system may need to be shutdown to replace the server.

2. Locate and unscrew the thumb screws located on the front of the node.
3. Grasp the node and pull with even pressure until the system will not extend further.
4. Unlatch the node from the rack.
 - a. Locate the safety latch release lever on the side of the inner rail.

Figure 3-89. Latch Release levers

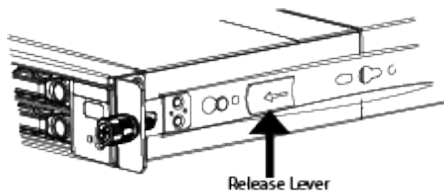

- b. To unlatch, press the latch release levers toward the front of the system. The node is now free from the rack and can be fully removed.
5. Carefully remove the node from the system.
6. Using a #2 Phillips Head Screwdriver, remove the rack mount rails.

3.7.2.2 Installing a 1U mounting kit

To install a 1U mounting kit:

1. Remove the inner rail from the new rail assembly.
2. Attach the inner rail to the server.
 - a. Attach the inner rail by aligning the holes in the inner rail with the pegs on the side of the server and sliding them forward to lock them in place.

Figure 3-90. Locking the inner rail to the node

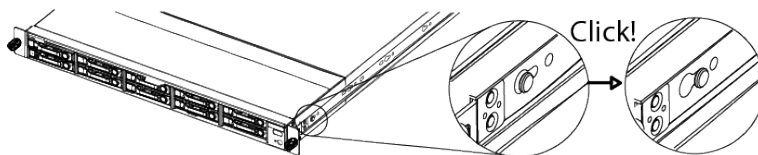

- b. Secure the inner rail to the node using one of the screws in the screw hole shown.

Figure 3-91. Attaching the inner rail to the server

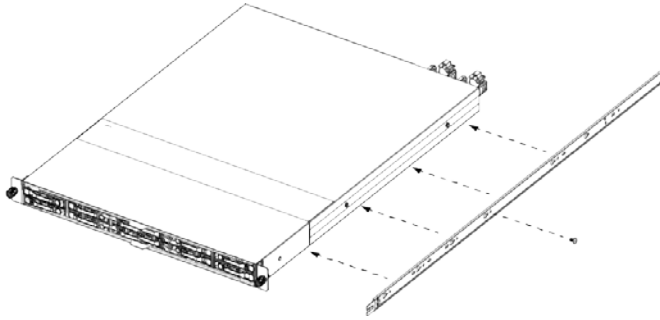

- 3. Attach the outer rail to the rack.
 - a. Extend the outer rail enough that the far end of the outer rail can reach the rear of the system.

Figure 3-92. Expanding the outer rail

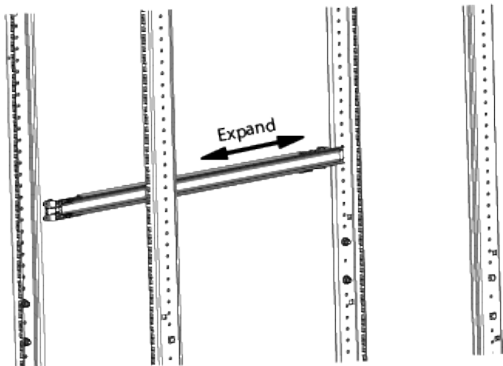

- b. While still standing at the front of the rack, Insert the mounting pegs on the far end of the outer rail into the mounting holes on the rear of the rack.

Figure 3-93. Attached outer rails

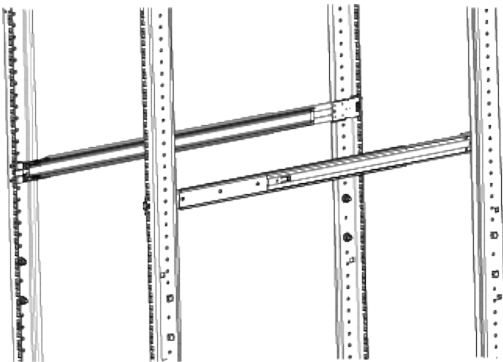

- c. With the mounting pegs inserted in the rear of the rack, mount the close end of the outer rail to the front of the rack by aligning the mounting pegs with the rack's mounting holes and slide them in until the latch closes.

3.7.3 Replacing the System Interconnect 1U mounting kit (racked systems)



Warning: Some components are heavy.



Caution: Disconnect all power sources before servicing.

Table 3-37. System Interconnect 1U mounting kit replacement overview

Required tools	Personnel	Replacement time
#2 Phillips head Screwdriver with torque measuring capabilities	1	20 min

3.7.3.1 Removing a System Interconnect 1U mounting kit

To remove a System Interconnect 1U mounting kit:

1. From the front of the rack, remove the 1U screen panel to gain access to the front of the System Interconnect.
2. Remove both power cords and all networking cables form the rear of the System Interconnect.
3. Locate and unscrew the screws on the front of the system that secure the System Interconnect to the rack mount rail.
4. Gripping the System Interconnect firmly with both hands, pull forward on the System Interconnect with even pressure until it releases from the rails on the rack.
5. From the rear of the rack, remove the screws that attach the rack mount rails to the rack.
6. From the front of the rack, remove the screws that attach the rack mount rails to the rack.

3.7.3.2 Installing a System Interconnect 1U mounting kit

To install a replacement 1U System Interconnect 1U mounting kit:

1. From the front of the rack, attach the new rack mount rails to the rack using the screws that were removed from the original rail kit.
2. If necessary, replace the inner rails on the System Interconnect.
3. Line up the System Interconnect with the rack mount rails.
4. Push the System Interconnect into the rack.
5. Secure the System Interconnect to the rack by replacing the screws.
6. Reconnect all of the cables in the back of the System Interconnect in the original configuration listed in [System cabling](#) on page 117.
7. From the front of the rack, attach the 1U screen panel to the rack in front of the System Interconnect.
8. Verify that the System Interconnect is back online.

3.7.4 Replacing System Interconnect 3U mounting kit (rackless systems)



Warning: Some components are heavy.



Caution: Disconnect all power sources before servicing.

Table 3-38. System Interconnect 3U mounting kit replacement overview

Required tools	Personnel	Replacement time
#2 Phillips head Screwdriver with torque measuring capabilities	1	20 min

3.7.4.1 Removing a 3U mounting kit

To remove a 3U mounting kit:

1. Shutdown the system.
 - a. Click **Resources**.
 - b. On multi-site systems, select a site from the **Sites** pull-down menu.
 - c. In the **Racks** pull-down menu, select a system.
 - d. In the rack's **Action** pull-down menu, select **Shutdown Rack**.

Figure 3-94. Resources > Rack > Shutdown



2. Remove the components from the faulty 3U mounting kit. For more information, refer to [Removing a System Interconnect](#) on page 58
3. From the rear of the rack and working on one bracket at a time, use a long Phillips head screwdriver and unscrew the two screws securing the washer plate to the 3U rail.

Warning: Make sure to hold the 3U bracket firmly and do not let go until it has completely cleared the rack. There is a danger of dropping the bracket and losing it in the interior of the rack, causing damage to the system, yourself, or others.

The washer plate will come free, but the 3U bracket will still be supported in the system by the mounting pegs on the bracket itself.

4. Move to the front of the rack and unscrew the two screws securing the 3U mounting bracket to the front of the rack.
5. Grasp a secure surface on the 3U bracket and apply pressure toward the back of the rack to collapse the bracket enough that it clears the front rack post.
6. Pull toward the front of the rack gently to release the mounting pegs from the rear of the rack. The 3U mounting bracket should now be free and can be removed.
7. Use the previous steps to remove the second 3U bracket.

3.7.4.2 Installing a 3U mounting kit

To install a replacement 3U mounting kit:

Important: Make sure that the mounting bracket is being attached to the correct side. The support flanges that the components will lie on should be facing toward

the inside of the rack. Flanges should be supporting components from the bottom of each U-space. If the flanges are not installed properly, the rail kit will not install correctly. In the case of an incorrect installation, the washer plates will not attach easily.

Tip: Have the mounting screws, washer plates, and screwdriver within reach while installing the 3U mounting kits. You will have to hold the mounting bracket being installed with one hand while installing the washer plates and screws with the other.

1. Fully extend the bracket you are installing.

Caution: If performing this task alone is too difficult or unsafe because of the build circumstances, have another person assist you. The second person can

support the 3U Mounting Kit at the rear of the rack while it is being secured to the front. This will prevent it from falling while it is being installed.

2. From the front of the rack, lead the pegged end of the mounting bracket into the rack, sliding the pegs into the mounting holes on the posts at the rear of the rack.
3. With the pegs inserted at the rear of the rack, slowly and carefully collapse the fully extended bracket until the screw holes on the bracket are flush behind the mounting holes on the front rack posts.
4. Hold the bracket flush with the mounting holes on the rack stems at the U level it will be installed at.
5. With your free hand, pick up the washer plate. Ensure that the standoffs or chamfered holes are facing out so the screws will sit flush.
6. Align the bracket flush with the rack post so the top screw hole is aligned with the holes on the rack post and the mounting bracket.
7. Use the hand holding the mounting bracket to pinch all of parts together with the rack post between them. This action will free your other hand.
8. Screw one of the M5 screws into the top mounting hole until it is finger tight. This will be enough to support the mounting bracket which will allow you to release your hand.
9. Finish securing the washerplate to the front of the rack with another M5 screw inserted into the bottom screw hole.
10. Use a level to ensure the mounting bracket is level. If it is not, retry mounting the bracket.
11. Once level, use a Phillips head screw driver to tighten the screws.
12. Move to the rear of the rack and install a flush washer plate to the rear of the rack. The screws should be installed as shown.

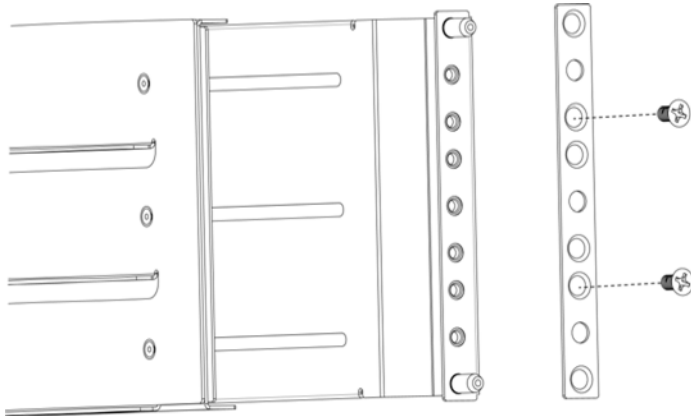

13. Re-install the components that you removed from the faulty 3U mounting kit. For more information, refer to [Installing a System Interconnect](#) on page 58.
14. Power the system back on by pressing the power buttons in this order, with a 3-5 second delay between each:
 1. The System Nodes
 2. Each Storage Enclosure Basic - Storage Node pair

Note: The PDUs automatically power up and supply power to the other components.

3.7.5 Replacing the Storage Enclosure Basic rail kit



Caution: Some components are heavy. The chassis is heavy and awkward. Grasp it securely during handling.



Caution: Disconnect all power sources before servicing.

Table 3-39. Storage Enclosure Basic rail kit replacement overview

Required Tools	Personnel	Replacement Time
<ul style="list-style-type: none"> • #2 Phillips-Head Screwdriver • T10 Screwdriver with torque measuring capabilities • Level 	1	50 min

3.7.5.1 Removing a Storage Enclosure Basic rail kit

To remove a Storage Enclosure Basic rail kit:

1. Using ActiveScale SM, shut down the Storage Node associated with the impacted Storage Enclosure Basic.
2. Remove the Storage Enclosure Basic chassis from the rack. For more information, refer to [Removing a Storage Enclosure Basic chassis](#) on page 93.
3. Gently pull the cables from the rail kit cable guides.
4. Remove the screws that secure the back end of the Storage Enclosure rail to the rear vertical rack rail.
5. Remove the screws holding the washer in place.
6. Remove the Storage Enclosure Basic rail from the rack.
7. Repeat these steps to remove the other rail.

3.7.5.2 Installing a Storage Enclosure Basic rail kit

Important: When assembling the rail kits for the Storage Enclosure Basic, insert screws loosely. Until directed to tighten the screws, all the screws on the rail kit should have approximately ¼" of thread showing. This can be achieved by

giving the screw one complete turn after the threads catch. Or you can put the screws all the way in, and then back the screw out three complete turns.

Important: Installing the rail kit correctly is critical to ensuring that the rail kits and chassis are installed correctly. The sleds will not fit if the rails are not installed correctly.

1. Extend the rail to its full length, and insert the hook on the back of the rail into the rear vertical rail.

Note: The extender at the back of the rail is not full-height. There will be two empty holes above the rack floor or above the previously installed Storage Enclosure Basic.

Figure 3-95. Rear View of Extender



2. Push the front of the rail back until it is flush behind the front vertical rail and insert screws with washers in the top and bottom holes of the rail.



Note: The chamfered side of the washer goes toward the rack.

Figure 3-96. Front Rail Flush Behind Front Vertical Rail



3. Align the back end of the rack mount rail with the back of the rail.
4. Loosely insert four screws to secure the back end of the rail to the rear vertical rail.

Figure 3-97. Back End to Rear Vertical Rail



5. repeat these steps to install the other rack mount rail and rear rail.
6. Verify that the bottom of each rail kit is in the same starting U position. That is, before proceeding, verify that the rail kits are at even height in the rack.
7. From the back of the rack, on the left side of the rack, run the two SAS cables and a power cable through the channel on the sides of the rails. (The female ends of the power cords go to the front of the rack.)

Figure 3-98. Back Rack SAS Cable Channel



8. Thread the SAS cables and the power cable between the front vertical rail and the front of the cabinet.

Figure 3-99. SAS Cables and Power Cable Front Vertical Routing



9. From the back of the rack, on the right side of the rack, run the power cable through the channel on the side of the rail and thread it between the front vertical rail and the front of the cabinet.

Figure 3-100. Power Cable Routing to Front of Cabinet



10. Reconnect the miniSAS cables.
11. Reconnect the enclosure to power.
12. Power on the Storage Node using the front power button.
13. Once the Storage Node is online, restart the Storage Enclosure.
14. Using ActiveScale SM, verify that:
 - The Storage Node is online and linked to the Storage Enclosure.
 - The Storage Enclosure is online and functional.

3.7.6 Front and rear rack doors



Caution: The rack doors are heavy.

Table 3-40. Rack door replacement overview

Required tools	Personnel	Replacement time
None	1	4 min.

Both the front and rear rack doors can be replaced using the procedures in this section.

3.7.6.1 Removing a front or rear rack door

To remove an ActiveScale X100 rack door:

1. Ensure the damaged door is unlatched and open partially.
2. Firmly grasp the door with both hands on either side of the door and lift until the hinge pins are clear of the rack.

Figure 3-101. Uninstalling the rack door



3. To avoid damage or injury, place the damaged door in a location away from the workspace.

3.7.6.2 Installing a front or rear rack door

To install a replacement ActiveScale X100 rack door:

1. Firmly grasp the replacement door with both hands and lift until the hinge pins are lined up with the hinges on the rack.

Figure 3-102. Rack door hinges

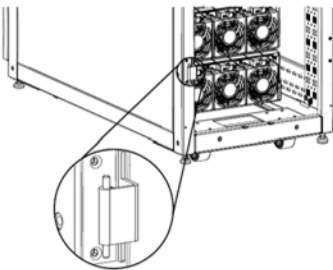

2. Firmly seat the door into the hinges.

Figure 3-103. Installing the rack door

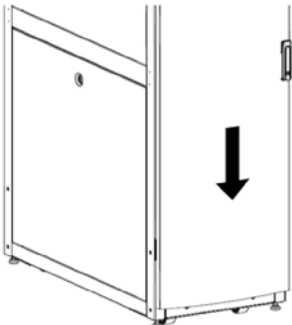

3. Verify that the door is secure and can open and close without any issues.

3.7.7 Rack tip plates



Caution: The system is very heavy and will require four people for the installation.



Caution: Disconnect all power sources before servicing.

Table 3-41. Rack tip plate replacement overview

Required Tools	Personnel	Replacement Time
<ul style="list-style-type: none"> • Socket set or socket conversion for a powered drill • 9/16" socket drive • Drill (optional) • Adjustable Wrench • Tape Measure 	4	30 min

3.7.7.1 Removing the rack tip plates

To remove the tip plates:

1. Shut down the system from the CM.
2. Disconnect the system cabling.
 - a. Shut power off from the datacenter power source.
 - b. Remove power cords from datacenter power source.
 - c. Remove datacenter networking cables that are connected to the system.
3. Using an adjustable wrench, raise the rack feet until the casters are the only part of the rack touching the floor.
4. Using a socket wrench, remove the kick plates.
 - a. From the rear of the rack, remove the bolts connecting the kick plate to the tip plate.
 - b. From the front of the rack, remove the bolts connecting the kick plate to the tip plate.

Figure 3-104. Removing the kick plate

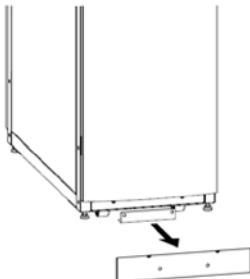

5. Carefully move the system into the cold aisle and ensure is clear of both floor-mounted tip plates.

Figure 3-105. Moving the System

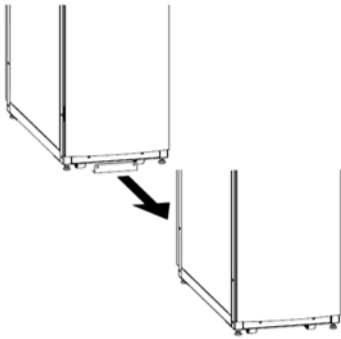

6. Using a socket wrench, remove both tip plates from the floor.

3.7.7.2 Installing rack tip plates

Caution: The system is very heavy 2227 lbs (1010 kg). Ensure that there are no tripping hazards along the path.

To install replacement rack tip plates:

1. Using a socket wrench, attach both tip plates to the floor in the same configuration as the damaged tip plates at approximately 47.25 in (1200.15 mm) from outer edge to outer edge.

Figure 3-106. Installing new tip plates



2. Carefully move the system back into place and ensure the tip plates are clear of the system casters.

Figure 3-107. Moving the system into place

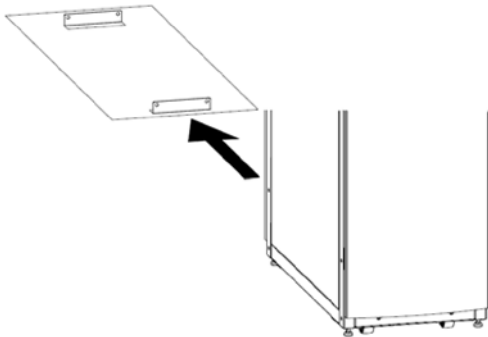

3. Using a socket wrench, attach the kick plates.
 - a. From the rear of the rack, attach the kick plate to the tip plate using the four bolts provided.
 - b. From the front of the rack, attach the kick plate to the tip plate using the four bolts provided.

Figure 3-108. Attaching kick plates

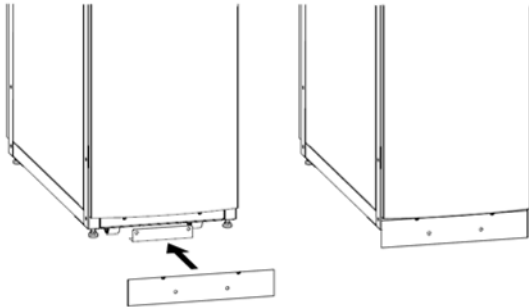

4. Using an adjustable wrench, lower the rack feet to level the system.

Warning: Do not lower the rack enough to lift the casters off of the floor. The rack feet are designed to share the weight of the system with casters. Improper use of these features may result in damage to rack or become a danger to the data center personnel.

5. Reconnect the power and network cables.
6. Restart the system.

4 System cabling

This section instructs you on how to properly read and assess the information on cable labels for installation, repairs, and troubleshooting. There is also information specific to both single-phase and 3-phase PDUs for all component power cords and network cables.

4.1 Reading cable labels

Cable labels in ActiveScale systems use a standard format to indicate where they should be connected in the system. This format is based on a set of provided component and port abbreviations.

Components and ports are numbered and abbreviated as shown. System Nodes that are installed as part of a System Expansion Node kit use the abbreviation **SEN**.

Note: System Expansion Nodes have unlabeled cables. When cabling System Expansion Nodes, refer to the cable wiring key on the System Interconnect and the diagrams in this section for the correct cable locations.

Figure 4-109. ActiveScale X100—Components and port identification

Management Interconnect (MSW)

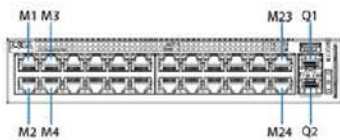

System Interconnect (SW)

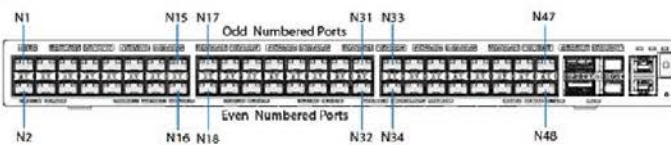

System Node (SN)

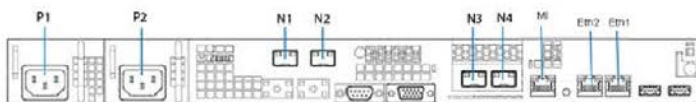

System Expansion Node (SEN)

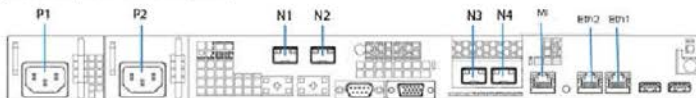

Storage Node (CSN)

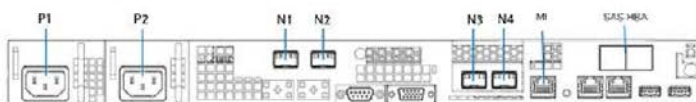

Storage Enclosure (DA)

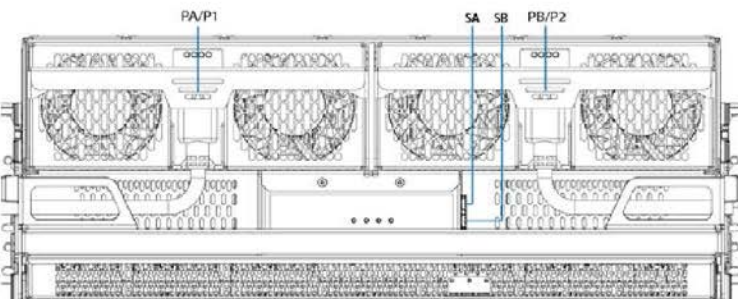

Using these port numbers and component abbreviations, you can determine the connection points for each cable.

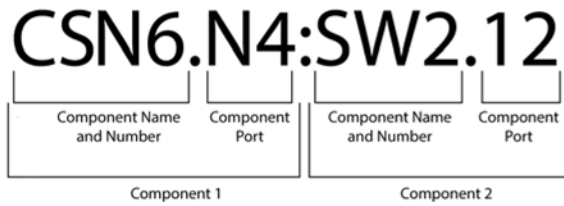
Figure 4-110. Example cable label**Table 4-42. Example cable label key**

Component	Component name and number	Component port	Location
Component 1	CSN6	N4	Storage Node 6, port 4
Component 2	SW2	12	System Interconnect 2, port 12

4.2 Cabling map

The following table and cabling diagram provide the information needed to connect the cables to the correct component.

Figure 4-111. ActiveScale X100—cable wiring key

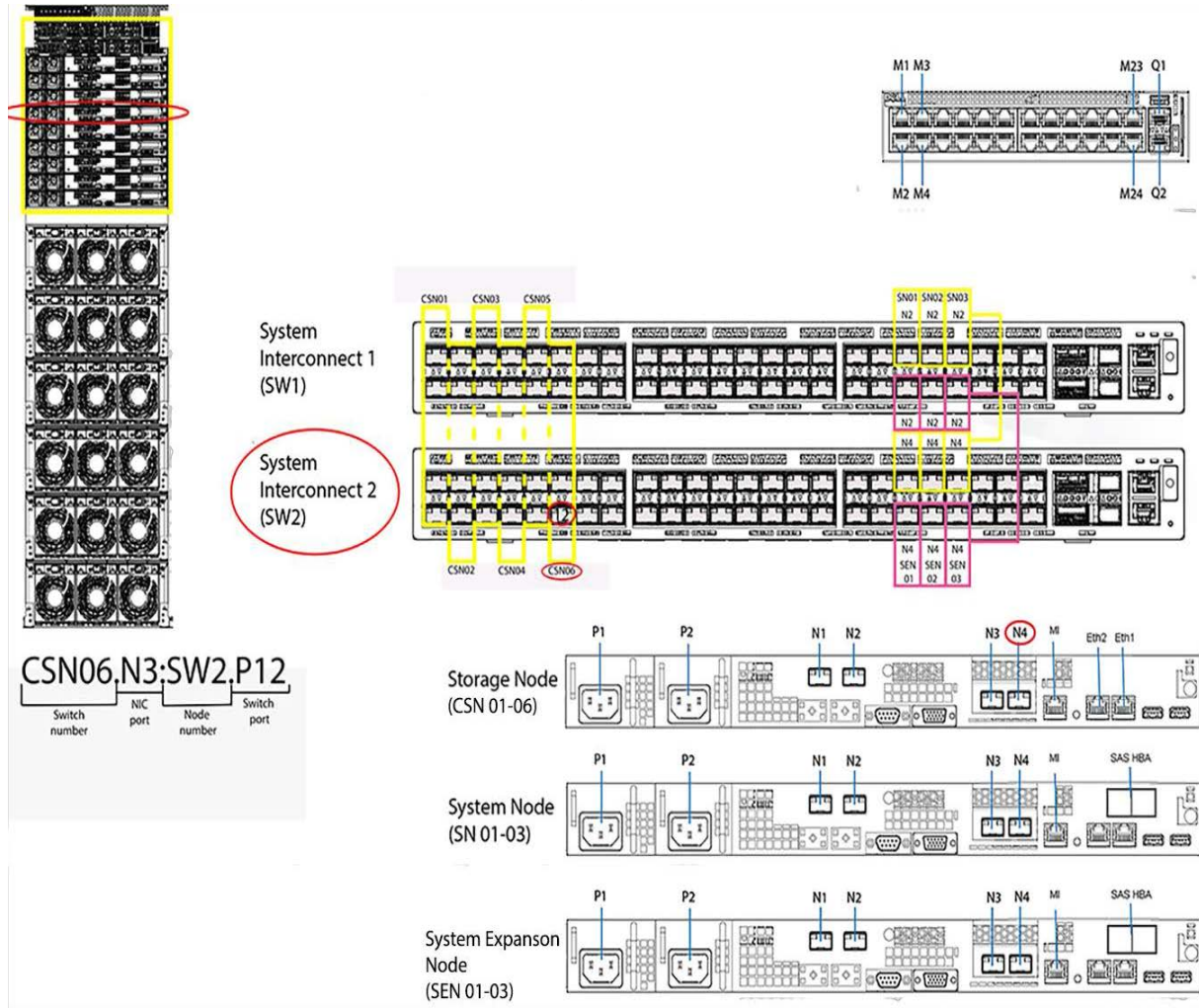

4.3 Cabling for single-phase PDU configurations

This table provides the information needed to connect the system signal cables for single-phase PDUs to the correct component:

Table 4-43. Single-phase PDU system signal connections

SEN03 ¹	M5	SEN3.M5:MSW.M15	M15	MSW
SEN02 ¹	M5	SEN2.M5:MSW.M14	M14	MSW
SEN01 ¹	M5	SEN1.M5:MSW.M13	M13	MSW
SN03	M5	SN3.M5:MSW.M21	M21	MSW
SN02	M5	SN2.M5:MSW.M20	M20	MSW
SN01	M5	SN1.M5:MSW.M19	M19	MSW
CSN06	M5	CSN6.M5:MSW.M6	M6	MSW
CSN05	M5	CSN5.M5:MSW.M5	M5	MSW
CSN04	M5	CSN4.M5:MSW.M4	M4	MSW
CSN03	M5	CSN3.M5:MSW.M3	M3	MSW

Table 4-43. Single-phase PDU system signal connections

CSN02	M5	CSN2.M5:MSW.M2	M2	MSW
CSN01	M5	CSN1.M5:MSW.M1	M1	MSW
PD01	M1	PD1.M1:MSW.M23	M23	MSW

1. System Expansion Nodes use unlabeled cables.

The following tables provide the information needed to connect the system power cords to the single-phase PDUs:

Table 4-44. PDUs 1-4

PDUs 1 and 3				
Plug	Current (A)	Component	Port	Time on (s)
C-13	1.16	System Expansion Node 2	29	30
C-13	1.06	System Interconnect 2	5	0
C-13	1.16	System Node 2	12	20
C-13	1.16	System Node 1	9	10
C-13	1.15	Storage Node 6	27	60
C-13	1.15	Storage Node 5	22	50
C-13	1.15	Storage Node 4	26	60
C-13	4.3	Storage Enclosure Basic 6	17	40
C-13	4.3	Storage Enclosure Basic 5	7	10
C-13	4.3	Storage Enclosure Basic 4	16	40
	20.89 Total			
PDUs 2 and 4				
Plug	Current (A)	Component	Port	Time on (s)
C-13	1.16	System Expansion Node 3	29	30
C-13	1.16	System Expansion Node 1	28	30
C-13	0.1	Management Interconnect ¹	4	0
C-13	1.06	System Interconnect 1	5	0
C-13	1.16	System Node 3	12	20
C-13	1.15	Storage Node 3	23	50
C-13	1.15	Storage Node 2	26	60
C-13	1.15	Storage Node 1	16	40
C-13	4.3	Storage Enclosure Basic 3	7	10
C-13	4.3	Storage Enclosure Basic 2	22	50
C-13	4.3	Storage Enclosure Basic 1	13	20
	20.99 Total			

1. PDU 2 only.

4.4 Cabling for three-phase PDU configurations

This table provides the information needed to connect the system signal cables for 3-phase PDUs to the correct component:

Table 4-45. Three-phase PDU system signal cables

Local device	Local port	Cable location	Peer port	Peer device
SEN03 ¹	N2	SEN3.N2.SW2.42	42	SW2
	N4	SEN3.N4.SW1.42	42	SW1
SEN02 ¹	N2	SEN2.N2.SW2.40	40	SW2
	N4	SEN2.N4.SW1.40	40	SW1
SEN01 ¹	N2	SEN1.N2.SW2.38	38	SW2
	N4	SEN1.N4.SW1.38	38	SW1
SN03	M5	SN3.M5:MSW.M21	M21	MSW
SN02	M5	SN2.M5:MSW.M20	M20	MSW
SN01	M5	SN1.M5:MSW.M19	M19	MSW
SCN06	M5	SCN6.M5:MSW.M6	M6	MSW
SCN05	M5	SCN5.M5:MSW.M5	M5	MSW
SCN04	M5	SCN4.M5:MSW.M4	M4	MSW
SCN03	M5	SCN3.M5:MSW.M3	M3	MSW
SCN02	M5	SCN2.M5:MSW.M2	M2	MSW
SCN01	M5	SCN1.M5:MSW.M1	M1	MSW
PD01	M1	PD1.M1:MSW.M23	M23	MSW
PD02	M1	PD2.M1:MSW.M24	M24	MSW
MSW	Q1	MSW.Q1:SW1.N43	N43	SW1
SN03	N2	SN3.N2:SW1.N41	N41	SW1
	N4	SN3.N3:SW2.N41	N41	SW2
SN02	N2	SN2.N2:SW1.N39	N39	SW1
	N4	SN2.N3:SW2.N39	N39	SW2
SN01	N2	SN1.N2:SW1.N37	N37	SW1

1. System Expansion Nodes use unlabeled cables.

The following tables provide the information needed to connect the system power cords to the three-phase PDUs:

4.4.1.1 Three-phase across two PDUs

Table 4-46. Three-phase across two PDUs - PDUs 1 and 2

Branch ZX				
Plug	Current (A)	Component	Port	Time on (s)
C-13	1.16	System Expansion Node 3	28	30
C-13	1.15	Storage Node 6	27	60
C-13	1.15	Storage Node 5	26	50
C-13	4.3	Storage Enclosure Basic 6	25	40
C-13	1.16	System Node 3	24	20
C-13	4.3	Storage Enclosure Basic 5	23	10
C-13	1.06	System Interconnect 2	22	0
	14.28 Total			
Branch YZ				
Plug	Current (A)	Component	Port	Time on (s)
C-13	1.16	System Expansion Node 2	19	30
5-13	1.15	Storage Node 4	17	60
C-13	1.15	Storage Node 3	16	50
C-13	4.3	Storage Enclosure Basic 4	15	40
C-13	1.16	System Node 2	18	20
C-13	4.3	Storage Enclosure Basic 3	13	10
C-13	1.06	System Interconnect 1	12	0
	13.32 Total			
Branch XY				
Plug	Current (A)	Component	Port	Time on (s)
C-13	1.16	System Expansion Node 1	8	30
C-13	1.15	Storage Node 2	7	60
C-13	4.3	Storage Enclosure Basic 2	6	50
C-13	1.15	Storage Node 1	5	40
C-13	4.3	System Expansion Node 1	4	20
C-13	1.16	System Node 1	3	10
C-13	0.1	Management Interconnect ¹	2	0
	13.32 Total			

1.PDU 1 only.

4.4.1.2 Three-phase across three PDUs

Table 4-47. Three-phase across three PDUs - PDU 1

Branch ZX				
------------------	--	--	--	--

Plug	Current (A)	Component	Port	Time on (s)
C-13	2.02	System Expansion Node 3	28	30
C-13	1.15	Storage Node 6	27	60
C-13	4.3	Storage Enclosure Basic 6	25	40
C-13	1.16	System Node 3	24	20
C-13	1.06	System Interconnect 2	22	0
	9.69 Total			
Branch YZ				
Plug	Current (A)	Component	Port	Time on (s)
C-13	2.02	System Expansion Node 2	19	30
C-13	1.15	Storage Node 3	16	50
C-13	1.16	System Node 2	18	20
C-13	4.3	Storage Enclosure Basic 3	13	10
C-13	1.06	System Interconnect 1	12	0
	9.69 Total			
Branch XY				
Plug	Current (A)	Component	Port	Time on (s)
C-13	1.15	Storage Node 2	7	60
C-13	4.3	Storage Enclosure Basic 2	6	50
C-13	1.15	Storage Node 1	5	40
C-13	4.3	Storage Enclosure Basic 1	4	20
	10.9 Total			

Table 4-48. Three-phase across three PDUs - PDU 2

Branch ZX				
Plug	Current (A)	Component	Port	Time on (s)
C-13	1.15	Storage Node 6	27	60
C-13	1.15	Storage Node 5	26	50
C-13	4.3	Storage Enclosure Basic 6	25	40
C-13	4.3	Storage Enclosure Basic 5	23	10
	10.9 Total			
Branch YZ				
Plug	Current (A)	Component	Port	Time on (s)
C-13	2.02	System Expansion Node 2	19	30
C-13	1.15	Storage Node 4	17	60
C-13	4.3	Storage Enclosure Basic 4	15	40
C-13	2.02	System Node 2	18	20
C-13	1.06	System Interconnect 1	12	0
	10.55 Total			
Branch XY				
Plug	Current (A)	Component	Port	Time on (s)
C-13	2.02	System Expansion Node 1	8	30
C-13	1.15	Storage Node 1	5	40
C-13	4.3	Storage Enclosure Basic 1	4	20
C-13	1.16	System Node 1	3	10
C-13	0.1	Management Switch	2	0
	8.73 Total			

Table 4-49. Three-phase across three PDUs - PDU 3

Branch ZX				
Plug	Current (A)	Component	Port	Time on (s)
C-13	2.02	System Expansion Node 3	28	30
C-13	1.15	Storage Node 5	26	50
C-13	1.16	System Node 3	24	20
C-13	4.3	Storage Enclosure Basic 5	23	10
C-13	1.06	System Interconnect 2	22	0
	9.69 Total			
Branch YZ				
Plug	Current (A)	Component	Port	Time on (s)
C-13	1.15	Storage Node 4	17	60
C-13	1.15	Storage Node 3	16	50

C-13	4.3	Storage Enclosure Basic 4	15	40
C-13	4.3	Storage Enclosure Basic 3	13	10
	10.9 Total			
Branch XY				
Plug	Current (A)	Component	Port	Time on (s)
C-13	2.02	System Expansion Node 1	8	30
C-13	1.15	Storage Node 2	7	60
C-13	4.3	Storage Enclosure Basic 2	6	50
C-13	1.16	System Node 1	3	10
	9.69 Total			

4.4.1.3 Management Interconnect cabling

Note: The Management Interconnect is installed above the System Interconnect. However, in this illustration, it is represented below the System Interconnects to simplify the diagram.

Figure 4-112. Cabling diagram for the Management Interconnect

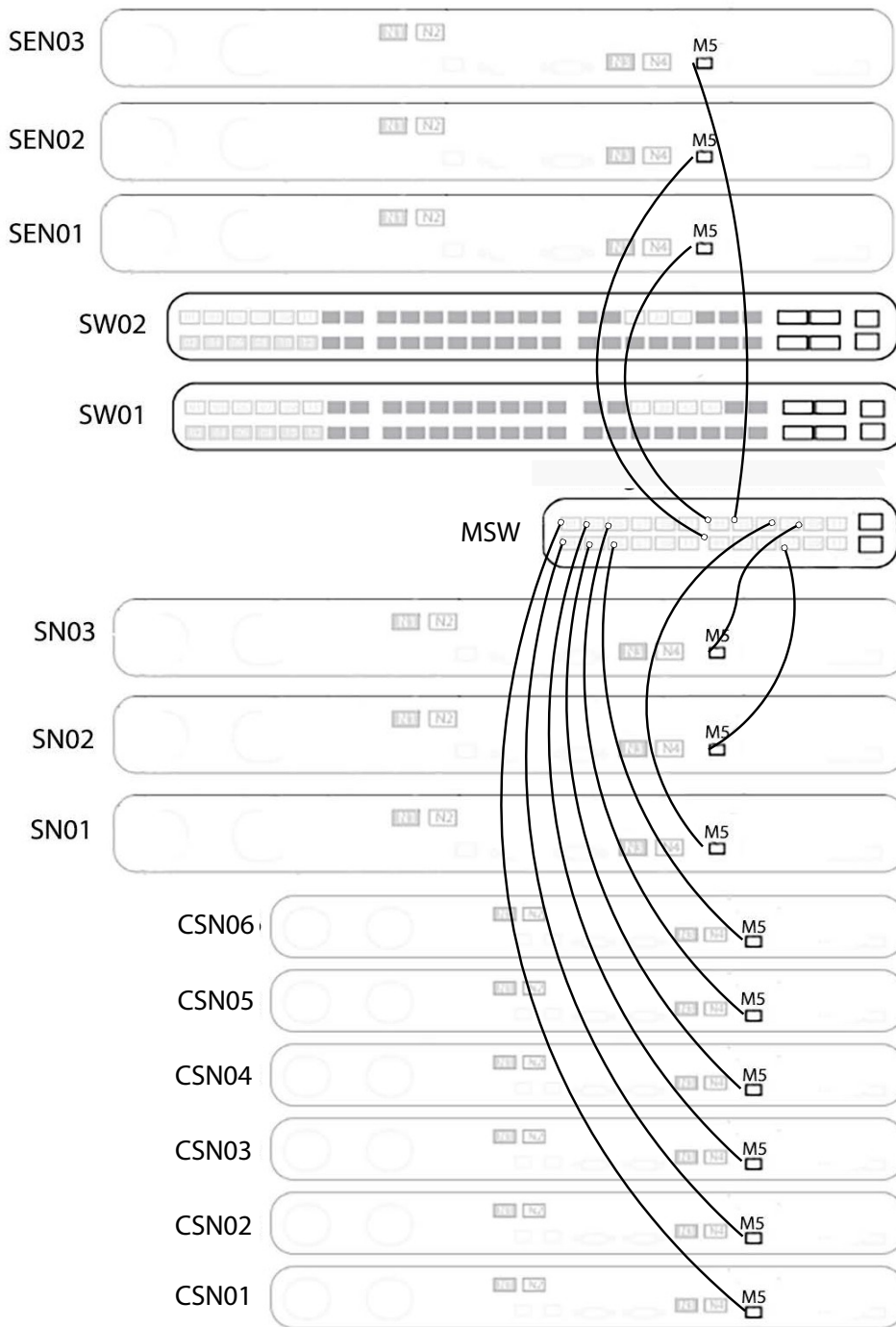

Note: The rackless version of ActiveScale X100 does not support monitoring PDUs. However, if you have purchased PDUs directly from Quantum Corporation specifically for ActiveScale X100, then contact customer support

for instructions on cabling PDUs to the Management Interconnect and for enabling PDU monitoring in the ActiveScale X100 system.

4.5 Single-phase PDU power sequencing

In general, each component uses the same timing with the following exceptions:

- PDU 2 contains the single Management Interconnect power connection.
- PDUs 1 and 3 contain two System Nodes.
- PDUs 2 and 4 contain one System Node.

Table 4-50. Single-phase power sequencing - PDU 1

XY PDU port	Component	Programmed delay
AA1	Not used	0
AA2	Not used	0
AA3	Not used	0
AA4	Not used	0
AA5	System Interconnect 2	0
AA6	Not used	0
AA7	Storage Enclosure Basic 5	10
AA8	Not used	0
AA9	System Node 1	10
AA10	Not used	0
AA11	Not used	0
AA12	System Node 2	20
AA13	Not used	0
AA14	Not used	0
AA15	Not used	0
AA16	Storage Enclosure Basic 4	40
AA17	Storage Enclosure Basic 6	40
AA18	Not used	0
AA19	Not used	0
AA20	Not used	0
AA21	Not used	0
AA22	Storage Node 5	50
AA23	Not used	0
AA24	Not used	0
AA25	Not used	0
AA26	Storage Node 4	60
AA27	Storage Node 6	60
AA28	Not used	0

Table 4-50. Single-phase power sequencing - PDU 1

XY PDU port	Component	Programmed delay
AA29	System Expansion Node 2	30
AA30	Not used	0

Table 4-51. Single-phase power sequencing - PDU 2

XY PDU port	Component	Programmed delay
AA1	Not used	0
AA2	Not used	0
AA3	Not used	0
AA4	Management Interconnect	0
AA5	System Interconnect 1	0
AA6	Not used	0
AA7	Storage Enclosure Basic 3	10
AA8	Not used	10
AA9	Not used	10
AA10	Not used	10
AA11	Not used	10
AA12	System Node 3	20
AA13	Storage Enclosure Basic 1	20
AA14	Not used	0
AA15	Not used	0
AA16	Storage Node 1	40
AA17	Not used	0
AA18	Not used	0
AA19	Not used	0
AA20	Not used	0
AA21	Not used	0
AA22	Storage Enclosure Basic 2	50
AA23	Storage Node 3	50
AA24	Not used	0
AA25	Not used	0
AA26	System Node 2	60
AA27	Not used	0
AA28	System Expansion Node 1	30
AA29	System Expansion Node 3	30
AA30	Not used	0

Table 4-52. Single-phase power sequencing - PDU 3

XY PDU port	Component	Programmed delay
AA1	Not used	0
AA2	Not used	0
AA3	Not used	0
AA4	Not used	0
AA5	System Interconnect 2	0
AA6	Not used	0
AA7	System Interconnect 5	10
AA8	Not used	0
AA9	System Node 1	10
AA10	Not used	0
AA11	Not used	0
AA12	System Node 2	20
AA13	Not used	0
AA14	Not used	0
AA15	Not used	0
AA16	Storage Enclosure Basic 4	40
AA17	Storage Enclosure Basic 6	40
AA18	Not used	0
AA19	Not used	0
AA20	Not used	0
AA21	Not used	0
AA22	Storage Node 5	50
AA23	Not used	0
AA24	Not used	0
AA25	Not used	0
AA26	Storage Node 4	60
AA27	Storage Node 6	60
AA28	Not used	0
AA29	System Expansion Node 2	0
AA30	Not used	0

Table 4-53. Single-phase power sequencing - PDU 4

XY PDU port	Component	Programmed delay
AA1	Not used	0
AA2	Not used	0
AA3	Not used	0

Table 4-53. Single-phase power sequencing - PDU 4

XY PDU port	Component	Programmed delay
AA4	Not used	0
AA5	System Interconnect 1	0
AA6	Not used	0
AA7	Storage Enclosure Basic 3	10
AA8	Not used	0
AA9	Not used	0
AA10	Not used	0
AA11	Not used	0
AA12	System Node 3	20
AA13	Storage Enclosure Basic 1	20
AA14	Not used	0
AA15	Not used	0
AA16	Storage Node 1	40
AA17	Not used	0
AA18	Not used	0
AA19	Not used	0
AA20	Not used	0
AA21	Not used	0
AA22	Storage Enclosure Basic 2	50
AA23	Storage Node 3	50
AA24	Not used	0
AA25	Not used	0
AA26	Storage Node 2	60
AA27	Not used	0
AA28	System Expansion Node 1	0
AA29	System Expansion Node 3	0
AA30	Not used	0

4.6 Three-phase PDU power sequencing

Each of the system components that are plugged into the PDU are balanced across the three-phase branches. Each branch contains 2 Storage Enclosure Basics, 2 Storage Node, and 1 System Node attached to it.

The only minor imbalance occurs to the phase that contains the different switches attached to it.

- Branch 1 has the Management Interconnect
- Branch 2 has **one** System Interconnect attached
- Branch 3 has **one** System Interconnect attached

The general order of power on is the switches power on first, then stagger the Storage Enclosure Basics on, then the Storage Node, then the System Node.

In some cases, System Expansion Nodes might require a third PDU. If your system is using one of the following power options, an additional PDU is required:

- (United States only) NEMA L21-30p plug, 3 phase delta, 208V 30A
- (United States only) NEMA L15-30p plug, 3 phase delta, 208V 30A

In these cases, contact Quantum Corporation support.

The following tables display the timing of the sequencing:

Table 4-54. Three-phase power sequencing - PDU 1

XY PDU port	Component	Programmed delay
AA1	Not used	0
AA2	Management Interconnect	0
AA3	System Node 1	10
AA4	Storage Enclosure Basic 1	20
AA5	Storage Node 1	40
AA6	Storage Enclosure Basic 2	50
AA7	Storage Node 2	60
AA8	System Expansion Node 1	30
AA9	Not used	0
AA10	Not used	0
AA11	Not used	0
AA12	System Interconnect 1	0
AA13	Storage Enclosure Basic 3	10
AA14	Not used	0
AA15	Storage Enclosure Basic 4	40
AA16	Storage Node 3	50
AA17	Storage Node 4	60
AA18	System Node 2	20
AA19	System Expansion Node 2	30
AA20	Not used	0
AA21	Not used	0
AA22	System Interconnect 2	0
AA23	Storage Enclosure Basic 5	10
AA24	System Node 3	20

Table 4-54. Three-phase power sequencing - PDU 1

XY PDU port	Component	Programmed delay
AA25	Storage Enclosure Basic 6	40
AA26	Storage Node 5	50
AA27	Storage Node 6	60
AA28	System Expansion Node 3	30
AA29	Not used	0
AA30	Not used	0

Table 4-55. Three-phase power sequencing - PDU 2

XY PDU port	Component	Programmed delay
AA1	Not used	0
AA2	Not used	0
AA3	System Node 1	10
AA4	Storage Enclosure Basic 1	20
AA5	Storage Node 1	40
AA6	Storage Enclosure Basic 2	50
AA7	Storage Node 2	60
AA8	System Expansion Node 1	30
AA9	Not used	0
AA10	Not used	0
AA11	Not used	0
AA12	System Interconnect 1	0
AA13	Storage Enclosure Basic 3	10
AA14	Not used	0
AA15	Storage Enclosure Basic 4	40
AA16	Storage Node 3	50
AA17	Storage Node 4	60
AA18	System Node 2	20
AA19	System Expansion Node 2	30
AA20	Not used	0
AA21	Not used	0
AA22	System Interconnect 2	0
AA23	Storage Enclosure Basic 5	10
AA24	System Node 3	20
AA25	Storage Enclosure Basic 6	40
AA26	Storage Node 5	50
AA27	Storage Node 6	60

Table 4-55. Three-phase power sequencing - PDU 2

XY PDU port	Component	Programmed delay
AA28	System Expansion Node 3	30
AA29	Not used	0
AA30	Not used	0

5 Installing scale up kits

Scaling up the ActiveScale X100 is the process of adding sled columns to the Storage Enclosure Basics within the system to gain more drive capacity.

At a minimum, each ActiveScale X100 contains at least one column of fully-populated sleds. That is, there is a sled populated with drives in the first, left-hand position of each of the six Storage Enclosure Basics in the system.

Scale up means that additional columns of populated sleds can be added to an ActiveScale X100 system.

The following constraints apply:

- Each slot in a Storage Enclosure Basic must contain either a populated sled or a sled blank.
- Each Storage Enclosure Basic in the system must have the same configuration of populated sleds and sled blanks.
- Each sled must be fully populated with 14 drives.
- Fully populated sleds must be inserted contiguously on the left side of the Storage Enclosure Basic. That is, there can not be any sled blanks between populated sleds.
- Sleds must be added to Storage Enclosure Basics in one column increments. That is, ActiveScale X100 systems are scaled up in increments of six sleds.

On a multi-site system, you can scale up sites one by one or all at once.

5.1 Installing sled columns as part of scale up



Caution: Some components are heavy.



Caution: Disconnect all power sources before servicing.

Table 5-56. Installing sled columns for scale up overview

Required Tools	Personnel
None	1

Note: Follow this procedure in its entirety **on a single Storage Node-Storage Enclosure Basic pair**, starting with the lowest pair. Then, wait for ActiveScale

SM to display the Storage Node as ONLINE before repeating this procedure on the next Storage Node-Storage Enclosure Basic pair.

1. Stop reads/writes to the Storage Node-Storage Enclosure Basic pair by gracefully powering down the Storage Node.
 - a. Log into ActiveScale SM as admin.
 - b. Click **Resources**.
 - c. In the system graphic, select a Storage Node.
 - d. In the **Action** pull-down menu for that Storage Node, select **Shutdown**. The **Machine Shutdown** dialog appears.
 - e. Type the password for admin.
 - f. Click **Shut Down**.
2. In your data center, identify the Storage Enclosure Basic that is paired with the Storage Node that you shut down.
3. Remove the I/O module from the Storage Enclosure Basic.
 - a. Unplug the power cords from the Storage Enclosure Basic.
 - b. Unplug the HD miniSAS cables from the Storage Enclosure Basic by pulling the blue tab and removing the cable from the port.
 - c. Unlock the I/O module from the Storage Enclosure Basic by pulling the latch handle out and away from the I/O module.

Figure 5-113. Unlocking the I/O module

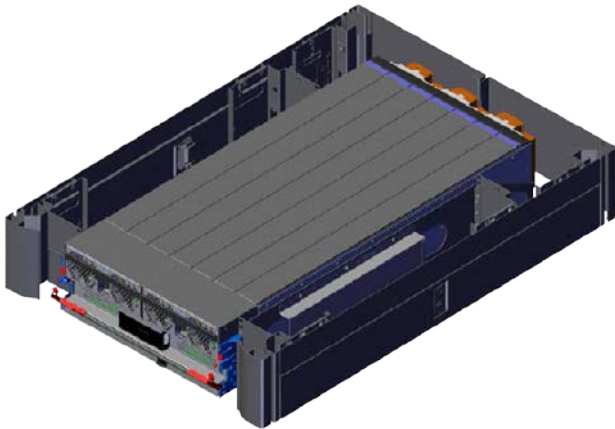

- a. Slide the I/O module away from the chassis.

Figure 5-114. Removing the I/O module

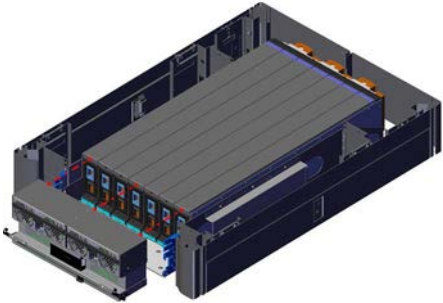

4. On the front of the leftmost sled blank, press the **latch mechanism button** and pull it until it is at a 45 degree angle.

Figure 5-115. Sled release button

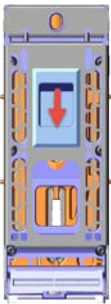
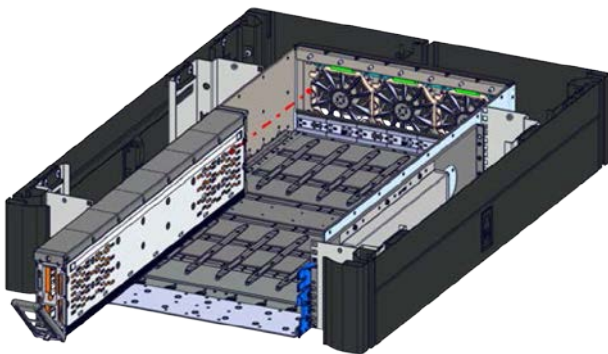
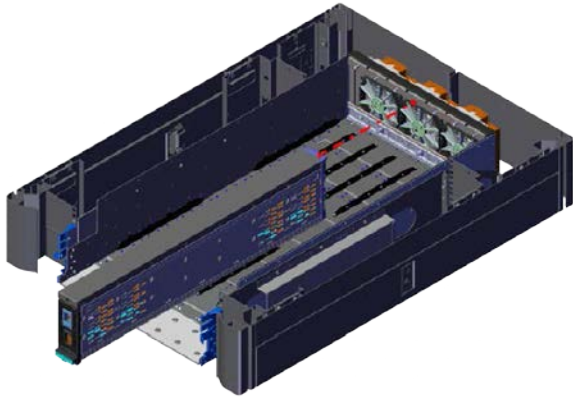

Figure 5-116. Sled release at 45 degrees



5. Pull the sled blank out of the chassis.

Figure 5-117. Removing the sled blank



6. Line the new populated sled up next to the last populated slot.
7. Slide the sled into the enclosure until fully seated.

Figure 5-118. Installing the sled

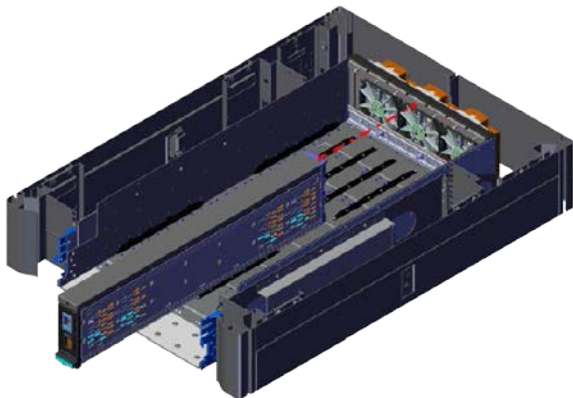

8. Install the I/O module into the Storage Enclosure Basic.
 - a. Set the I/O module half-way into the Storage Enclosure Basic chassis with the handle still unlocked.

Figure 5-119. Sliding the I/O module into the chassis

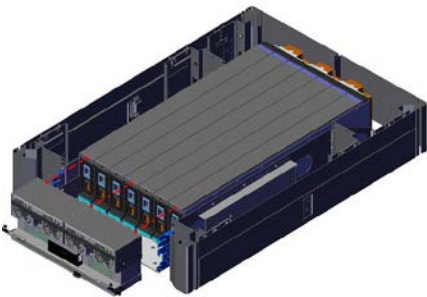

- b. Plug the HD miniSAS cables into the HD miniSAS ports.
- c. Route the power cords through the I/O module handle.

Important: Do not plug in the PSUs until the I/O module is fully seated.

- d. Push the I/O module into the chassis until seated against the sleds.
- e. Lock the I/O module handle by pushing rotating the I/O module handle up.

Figure 5-120. Locking the I/O module

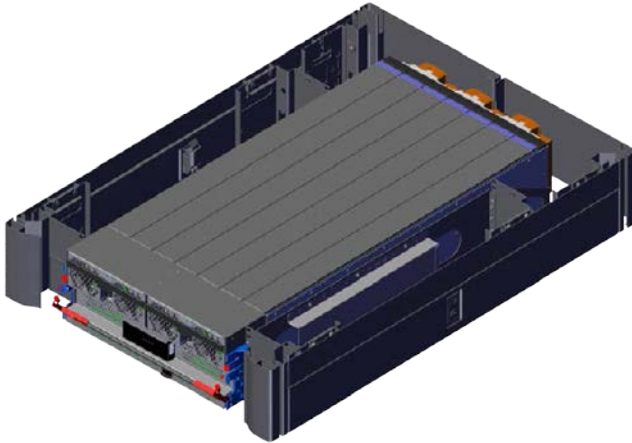

9. Plug the power cords into the power cord ports at the bottom of each power supply unit. The Storage Enclosure basic will power on automatically.
10. In ActiveScale SM, verify that sled installation succeeded.
 - a. In ActiveScale SM, click **Resources**.
 - b. In the system graphic, select the correct Storage Node and confirm that its status is **ONLINE**.
 - c. In the system graphic, select the correct Storage Enclosure Basic and confirm that:
 - Its status is **ONLINE**
 - The correct number and position of installed sled(s) is shown
 - Disks in the newly installed sled(s) have the status **NOTMANAGED**
11. Repeat this procedure (starting from step 1) for **each unvisited Storage Node- Storage Enclosure Basic pair at each site**.

5.2 Provisioning the newly added sleds on a single site system

Follow this procedure after you have completed the hardware steps for a **single** scale up kit. Each system must have identical scale up configurations.

Important: The system must be in a stable state before scaling up. The scale up job checks data safety levels when it starts. If the system is freshly installed, or if you just completed an initial scale up, wait 10-15 minutes for the system to stabilize and start recording data safety levels. This is particularly important if you purchased multiple columns for an initial install. Systems that have been running for some time may have a data safety issue as reported in ActiveScale SM. You must resolve any data safety issues before attempting to scale up. If the

data safety of the system is not optimal or there are failed drives, fix the issues by replacing the drives before starting this procedure.

Warning: You can only do one scale up at a time: complete the scale up of one system before starting the scale up of another system.

Warning: Components in the scale up kit might have newer firmware than your existing components have. This procedure does not upgrade or downgrade any firmware.

Warning: If a scale up or scale out job is already in progress, wait until the current job is complete to start the multi-site scale up job.

Warning: Do not start a log collection job while a scale up job is running.

1. Verify the health of the system.
 - a. Make sure all nodes are online.
 - b. Click **Configuration > System**.
 - c. In the **General Info** section, under **Health Check**, click **Run**.
 - d. Monitor the status of the health check job in the **Jobs** pane.
 - e. If the health check job has errors, stop. Contact Quantum Support for help.
2. Start the scale up wizard to provision newly populated sleds one by one.
 - a. Click **Configuration > Upgrade**.
 - b. In the **System Expansion** section, scroll down to **Scale Up**.
 - c. Click **Start**.

Figure 5-121. Starting a scale up



3. Enter the password for admin.

Figure 5-122. Scale up: Password verification



4. Click **Start Provisioning**.

Figure 5-123. Scale up: Start provisioning

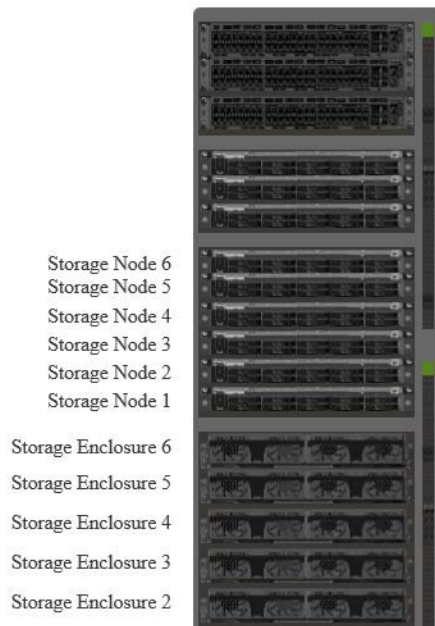

Let's get Started

Ready to Provision?

All drives, nodes and enclosures are correctly installed and completed the steps. Make sure storage nodes are powered up before proceeding.

[Start Provisioning](#)

The wizard displays a screen with a checklist of steps that you should have completed already.

5. If you have completed the steps listed, click **Provision**.

If you have not completed all steps in the checklist displayed, click **Back to Let's Get Started**, and complete them first.

Figure 5-124. Scale Up: Ready to provision

Ready to Provision

Checklist before provision

1. Storage Enclosure and SLEDS inserted in the correct order
2. Add capacity within SLEDS are evenly distributed
3. All cables are reconnected properly
4. Storage Enclosures and Storage Nodes are power up

Clicking on 'Provision' button will initiate a job and close the modal window. Progress can be monitored in the jobs page.



6. Navigate to the **Jobs** page, and wait until the scale up job indicates success or failure.

Tip: This takes about 1 hour for each newly installed sled column.

When the scale up job succeeds, its **Progress** bar is **100%** and its **Results** field is **Success**.

Figure 5-125. Scale up: Job success

Job Type	Job Status	Progress	Start Date↓	Duration	Results	Details	Actions
Scale Up	Completed	100%	10/20/16 4:12 PM	1 hr, 5 mins	Success		
Health Check	Completed	N/A	10/20/16 11:23 AM	2 mins	Failed		

If the scale up job fails, click the icon in its **Details** column to see why it failed and suggestions on how to correct the problem. Follow the suggestions.

7. Check the dashboard to confirm that the added capacity is reflected in the **Capacity** tile.

Figure 5-126. Scale up: Confirmation on dashboard



8. Check the **Resources** page to confirm that the newly provisioned sled is present.

Figure 5-127. Scale up: Confirmation on Resources page

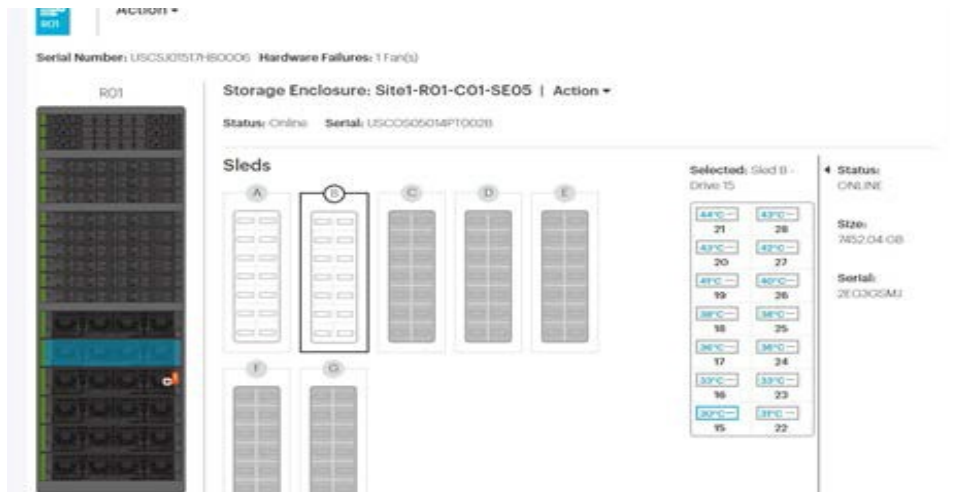

5.3 Provisioning the newly added sleds on a multi-site system

Follow this procedure after you have completed the hardware steps for a **single** scale up kit. Each system must have identical scale up configurations.

Note: During the scale up process, the system will be unbalanced (in other words, have different capacities at different sites) for more than a day. This

imbalance is handled by the system transparently; it does not cause any disruption to application I/O, data durability, or failovers.

Important: The system must be in a stable state before scaling up. The scale up job checks data safety levels when it starts. If the system is freshly installed, or if you just completed an initial scale up, wait 10-15 minutes for the system to stabilize and start recording data safety levels. This is particularly important if you purchased multiple columns for an initial install. Systems that have been running for some time may have a data safety issue as reported in ActiveScale SM. You must resolve any data safety issues before attempting to scale up. If the data safety of the system is not optimal or there are failed drives, fix the issues by replacing the drives before starting this procedure.

Warning: You can only do one scale up at a time. You must complete the scale up of one system before starting the scale up of another system. Even on multi-site deployments, you can only scale up one system at one site at a time. Because the scale up kits are factory installed to be

identical, adding two scale up kits simultaneously results in link-local IP address conflicts.

Warning: Components in the scale up kit might have newer firmware than your existing components have. This procedure does not upgrade or downgrade any firmware.

Warning: If a scale up or scale out job is already in progress, wait until the current job is complete to start the multi-site scale up job.

Warning: Do not start a log collection job while a scale up job is running.

1. Verify the health of the system.
 - a. Make sure all nodes are online.
 - b. Click **Configuration > System**.
 - c. In the **General Info** section, under **Health Check**, click **Run**.
 - d. Monitor the status of the health check job in the **Jobs** pane.
 - e. If the health check job has errors, stop. Contact Quantum Support for help.
2. Start the scale up wizard to provision newly populated sleds one by one.
 - a. Click **Configuration > Upgrade**.
 - b. In the **System Expansion** section, scroll down to **Scale Up**.
 - c. Click **Start**.

Figure 5-128. Starting a scale up

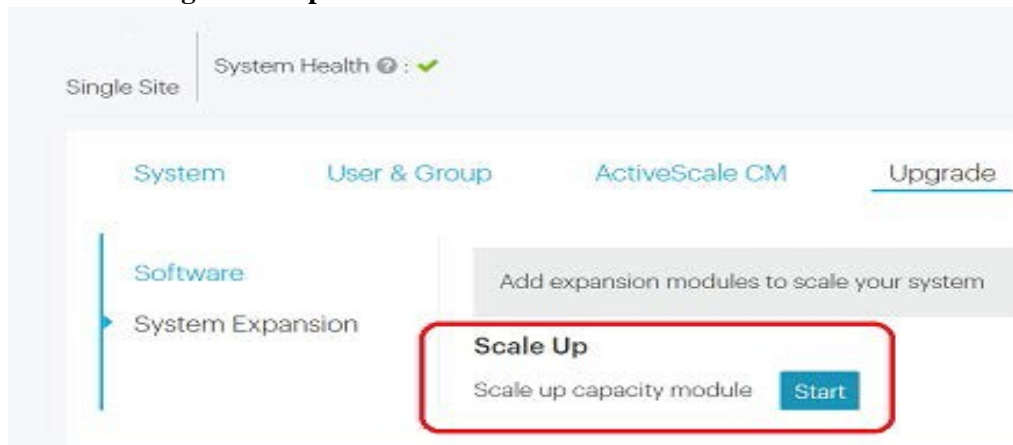

3. Enter the password for admin.

Figure 5-129. Scale up: Password verification



4. Click **Start Provisioning**.

Figure 5-130. Scale up: Start provisioning

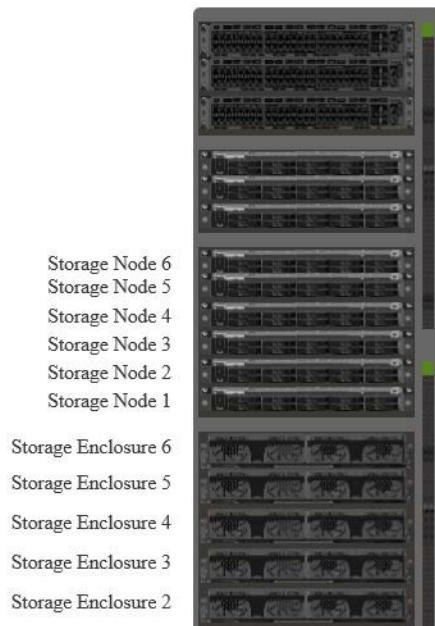

Let's get Started

Ready to Provision?

All drives, nodes and enclosures are correctly installed and completed the steps. Make sure storage nodes are powered up before proceeding.

[Start Provisioning](#)

The wizard displays a screen with a checklist of steps that you should have completed already.

5. If you have completed the steps listed, click **Provision**.

If you have not completed all steps in the checklist displayed, click **Back to Let's Get Started**, and complete them first.

Figure 5-131. Scale Up: Ready to provision

Ready to Provision

Checklist before provision

1. Storage Enclosure and SLEDS inserted in the correct order
2. Add capacity within SLEDS are evenly distributed
3. All cables are reconnected properly
4. Storage Enclosures and Storage Nodes are power up

Clicking on 'Provision' button will initiate a job and close the modal window. Progress can be monitored in the jobs page.



6. Navigate to the **Jobs** page, and wait until the scale up job indicates success or failure.

Tip: This takes about 1 hour for each newly installed sled column.

When the scale up job succeeds, its **Progress** bar is **100%** and its **Results** field is **Success**.

Figure 5-132. Scale up: Job success

Job Type	Job Status	Progress	Start Date	Duration	Results	Details	Actions
Scale Up	Completed	100%	10/20/16 4:12 PM	1 hr, 5 mins	Success		

If the scale up job fails, click the icon in its **Details** column to see why it failed and suggestions on how to correct the problem. Follow the suggestions.

7. Check the dashboard to confirm that the added capacity is reflected in the **Capacity** tile.

Figure 5-133. Scale up: Confirmation on dashboard



8. Check the **Resources** page to confirm that the newly provisioned sled is present.

Figure 5-134. Scale up: Confirmation on Resources page

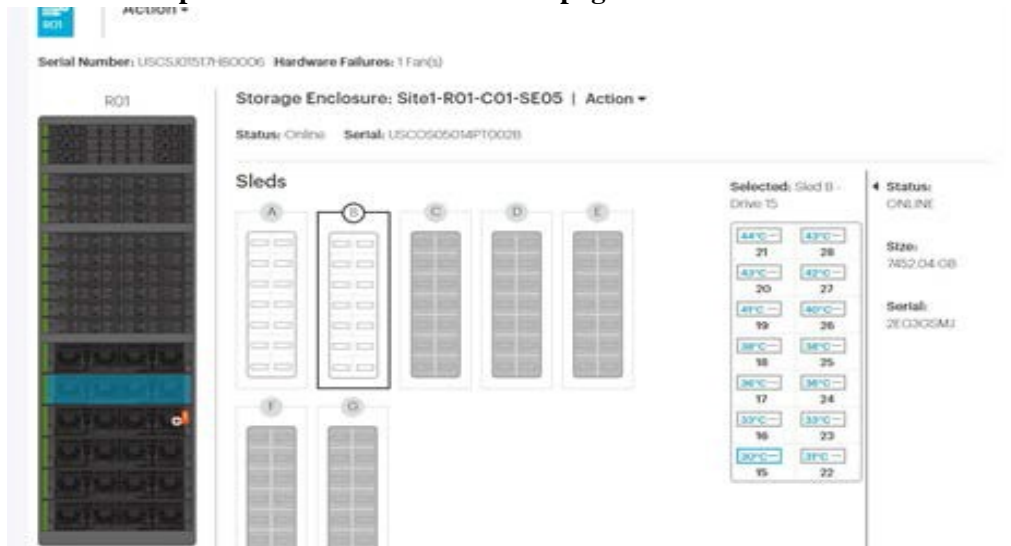

9. Perform the steps above on systems at the other sites.

6 Installing scale out kits

To scale out the system, you need to establish connections between the System Interconnects of the primary system and the System Interconnects of the secondary system, and run a wizard from the primary ActiveScale SM. This section walks you through the procedure.

6.1 Hardware steps

Complete these hardware steps before proceeding to the software steps for scale out. On multi-site systems, complete all hardware steps at each site before proceeding on to the software steps.

The steps below explain how to:

- Connect cables between the existing system and the new system.

Note: If both systems are new installations, complete the Customer Bringup Wizard on the first system, then connect the system interconnect links, and finally power up the servers on the second system.

- If necessary, reconfigure the ports on the new and existing systems.

Note: If the defaults were changed, reconfigure the ports on your systems for the links to come up.

- For multi-site systems, connect the uplinks to the networks.

6.2 Parts Required for Scale Out

Part	Description
Single-rack scale out connectivity kit Part number: 1EX0259	Contains four 40Gb male transceivers that plug into the scale out ports on the System Interconnects: <ul style="list-style-type: none"> • If you are adding a second system, you need two kits for a total of eight transceivers: four plug into the System Interconnect scale out ports on the first system, and four plug into the System Interconnect scale out ports on the second system. • If you are adding a third system or more, you only need one kit for a total of four transceivers; they plug into the System Interconnect scale out ports on the new system.
OM3 or OM4 MPO multi-mode fiber cables	<p>Important: These cables are customer supplied.</p> <ul style="list-style-type: none"> • OM3 cables must be 100m or shorter. That means your new system must be within 100m of your existing system. • OM4 cables must be 150m or shorter. That means your new system must be within 150m of your existing system. <p>Warning: If rack-to-rack connectivity uses customer infrastructure, Type-A, Type-B, or Type-C cables may be required.</p>

6.2.1 Additional Parts Required for Multi-Site Configuration

If you are performing a multi-site scale out, additional parts are required.

Table 6-57. Parts needed for per system, per site

System configuration	Uplink mode	Transceivers needed, per system, per site			Cables needed, per system, per site
		Type	Part number	Quantity	
ActiveScale X100, base system (one column)	Mode 1 (two individual 10G access ports (48,47) per System Interconnect)	SFP+ Finisar FTLX8574D3B CV-iT	1EX0272 (there are 4 in each kit)	1	2 10Gb cables per System Interconnect (4 cables total)
	Mode 2 (one 10G trunk (port 48) per System Interconnect)	SFP+ Finisar FTLX8574D3B CV-iT	1EX0279 (there are 2 in each kit)	1	1 10Gb cable per System Interconnect (2 cables total)
	Mode 3 (one 40G trunk (port 50) per System Interconnect)	QSFP+ ASM, FINISAR 40G QSFP+ SR OPTIC, FTL410QE3C	1EX0268 (there is 1 in each kit)	2	1 40Gb cable per System Interconnect (2 cables total)
	Mode 4 (three 10G trunks (ports 48,47,46) with LACP per System Interconnect)	SFP+ Finisar FTLX8574D3B CV-iT	1EX0279 (there are 2 in each kit)	3	3 10Gb cables per System Interconnect (6 cables total)
	Mode 5 (two 40G trunks (ports 50,52) with LACP per System Interconnect)	QSFP+ ASM, FINISAR 40G QSFP+ SR OPTIC, FTL410QE3C	1EX0268 (there is 1 in each kit)	2	2 40Gb cables per System Interconnect (4 cables total)

Note: The transceivers listed are shown with a part number you must purchase for each system. Purchase the part number specified for your chosen uplink mode. Part numbers correspond to upgrade kits. Cables are customer-supplied and must be *LC to LC multi-mode fiber optic patch cable* (LC multi-mode 50/125mm MMF OM3 or OM4 10Gb laser optimized fiber). These cables must comply with the Ethernet 10GBASE-SR standard. Ensure that, for the cable type chosen, you do not exceed the specified maximum 10GBASE-SR cable length. For example, do not exceed a length of 400m if you are using 10G OM4 multi-mode cables.

6.3 Connecting the Cables Between the Systems

To cable the systems, connect the cables between the systems to form a closed loop.

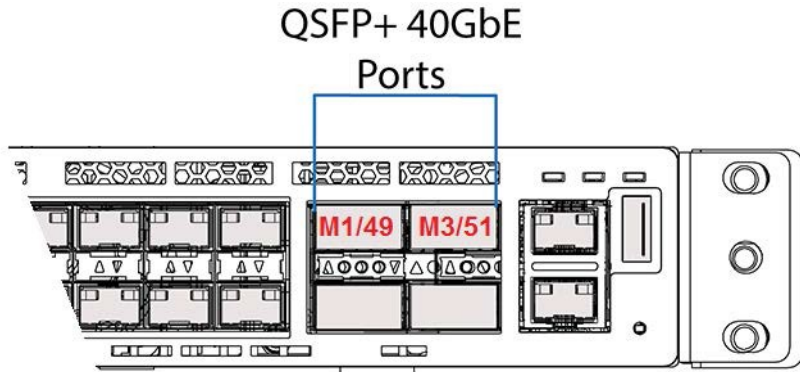
Figure 6-135. Location of scale out ports: 49 (M1) and 51 (M3)

6.3.1 Cabling Two Systems

Follow the instructions in this section if you are adding a second system (system 2) to your original system.

The figure below shows the correct scale out cabling between two systems using an OM3 MPO Type-B female-to-female rack-to-rack cable. If the rack to rack connectivity uses the customer infrastructure, Type-A, Type-B, or Type-C cables may be required.

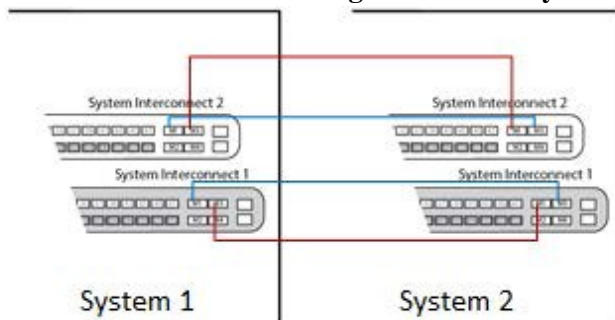
Figure 6-136. Scale out cabling between two systems

To cable system 2:

1. Insert 40Gb transceivers into ports 49 (M1) and 51 (M3) of System Interconnects 1 and 2 **on both systems**, for a total of eight transceivers plugged in.
2. Connect your OM3/OM4 cables to the transceivers you plugged in as follows:
 - Connect System 1, System Interconnect 1, port 49 to System 2, System Interconnect 1, port 51.
 - Connect System 1, System Interconnect 2, port 49 to System 2, System Interconnect 2, port 51.
 - Connect System 2, System Interconnect 1, port 49 to System 1, System Interconnect 1, port 51.
 - Connect System 2, System Interconnect 2, port 49 to System 1, System Interconnect 2, port 51.

6.4 Cabling Three Systems

Follow the instructions in this section if you are adding a third system (system 3).

This figure shows the correct scale out cabling between three systems using an OM3 MPO Type-B female-to-female rack-to-rack cable.

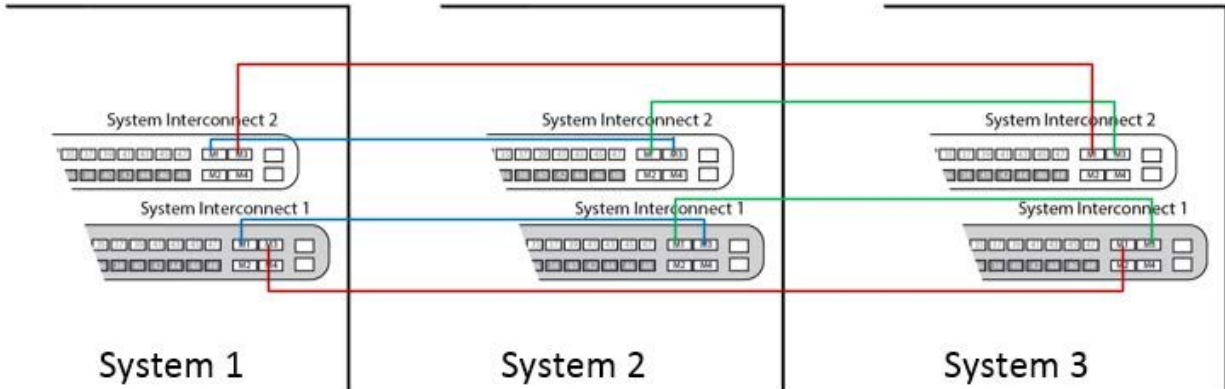
Figure 6-137. Scale out cabling between 3 systems

1. Insert 40Gb transceivers into ports 49 (M1) and 51 (M3) of System Interconnects 1 and 2 **on the new system**, for a total of four transceivers plugged in.
2. Disconnect and reconnect your OM3/OM4 cables to the transceivers you plugged in as follows:

Warning: Disconnect one cable at a time, otherwise you lose connectivity to your system entirely.

- d. Disconnect the cable in System 1, System Interconnect 1, port 51 and connect it to System 3, System Interconnect 1, port 51.
- e. Disconnect the cable in System 1, System Interconnect 2, port 51 and connect it to System 3, System Interconnect 2, port 51.
- f. Connect System 3, System Interconnect 1, port 49 to System 1, System Interconnect 1, port 51.
- g. Connect System 3, System Interconnect 2, port 49 to System 1, System Interconnect 2, port 51.

6.5 Opening Interconnect Ports

If the defaults were changed, reconfigure the ports on your systems for the links to come up.

1. Reconfigure the System Interconnects on the existing system:
 - a. Connect an Ethernet cable from your laptop to port 44 on System Interconnect 1 of the existing system.
 - b. Reconfigure the System Interconnects on the existing system:
 - a. Create an alias on your laptop to **System Interconnect 1** on the existing system:

Note: Change the IP address in the first alias to match your network settings, but do not change the link-local IP address in the second alias.

```
sudo ifconfig eth1:0 172.16.110.240 up #this IP address should match your setup
sudo ifconfig eth1:1 169.254.110.240 up
```

- b. Connect to **System Interconnect 1** (username: admin, no password):

```
lab@mw-<SystemIP>: $ telnet <IP_of_System_Interconnect_1> lab@mw-SystemIP: $ telnet IP of
System Interconnect 1 Trying 172.16.110.200...
Connected to 172.16.110.200. Escape character is '^]'. User:admin
Password:
```

- c. Run the following commands:

```
(SiteN_System_Interconnect1) >en
(SiteN_System_Interconnect1) #conf
(SiteN_System_Interconnect1) (Config)#interface 0/49
(SiteN_System_Interconnect1) (Interface 0/49)#no shutdown
(SiteN_System_Interconnect1) (Interface 0/49)#exit
(SiteN_System_Interconnect1) (Config)#interface 0/51
(SiteN_System_Interconnect1) (Interface 0/51)#no shutdown
(SiteN_System_Interconnect1) (Interface 0/51)#exit
(SiteN_System_Interconnect1) (Config)#exit
(SiteN_System_Interconnect1) #write memory confirm
Config file 'startup-config' created successfully. Configuration Saved!
(SiteN_System_Interconnect1) (Config)#show interfaces status all | include 0/49
0/49ScaleoutNetwork_InterconnectUp40G Full40G FullUnknown Active
(Site1_Storage_Interconnect1) (Config)#show interfaces status all | include 0/51
0/51ScaleoutNetwork_InterconnectUp40G FullUnknown Inactive
(SiteN_System_Interconnect1) (Config)#exit
```

2. Create an alias on your laptop to **System Interconnect 2** on the existing system:

Note: Change the IP address in the first alias to match your network settings, but do not change the link-local IP address in the second alias.

```
sudo ifconfig eth1:0 172.16.210.240 up #this IP address should match your setup
sudo ifconfig eth1:1 169.254.210.240 up
```

3. Connect to **System Interconnect 2** (username: admin, no password):

```
lab@mw-<System IP>:$ telnet <IP of System Interconnect 2> Trying 172.16.210.200...
Connected to 172.16.210.200. Escape character is '^'. User:admin
Password:
```

4. Run the following commands:

```
(SiteN_System_Interconnect2) >en
(SiteN_System_Interconnect2) #conf
(SiteN_System_Interconnect2) (Config)#interface 0/49
(SiteN_System_Interconnect2) (Interface 0/49)#no shutdown
(SiteN_System_Interconnect2) (Interface 0/49)#exit
(SiteN_System_Interconnect2) (Config)#interface 0/51
(SiteN_System_Interconnect2) (Interface 0/51)#no shutdown
(SiteN_System_Interconnect2) (Interface 0/51)#exit
(SiteN_System_Interconnect2) (Config)#exit
(SiteN_System_Interconnect2) #write memory confirm
Config file 'startup-config' created successfully. Configuration Saved!
(SiteN_System_Interconnect2) #show interfaces status all | include 0/49
0/49ScaleoutNetwork_InterconnectUp40G Full40G FullUnknown Active
(SiteN_System_Interconnect2) #show interfaces status all | include 0/51
0/51ScaleoutNetwork_InterconnectUp40G FullUnknown Inactive
(SiteN_System_Interconnect2) #quit
Connection closed by foreign host.
```

5. Reconfigure the System Interconnects on the new systems:

- Connect an Ethernet cable from your laptop to port 44 on System Interconnect 1 of the new system.
- Create an alias on your laptop to **System Interconnect 1** on the new system:

Note: Do not change the link-local IP address in the command below.

```
sudo ifconfig eth1:0 <ip_address> up
```

- c. Connect to **System Interconnect 1** (username: admin, no password):

```
lab@mw-<System IP>:~$ telnet <System Interconnect 1 IP> Trying
```

```
Connected to 169.254.110.200. Escape character is '^]'. User:admin
Password:
```

- d. Run the following commands:

```
(SiteN_System_Interconnect1) >en
(SiteN_System_Interconnect1) #conf
(SiteN_System_Interconnect1) (Config)#interface 0/49
(SiteN_System_Interconnect1) (Interface 0/49)#no shutdown
(SiteN_System_Interconnect1) (Interface 0/49)#exit
(SiteN_System_Interconnect1) (Config)#interface 0/51
(SiteN_System_Interconnect1) (Interface 0/51)#no shutdown
(SiteN_System_Interconnect1) (Interface 0/51)#exit
(SiteN_System_Interconnect1) (Config)#exit
(SiteN_System_Interconnect1) #write memory confirm
Config file 'startup-config' created successfully. Configuration Saved!
(SiteN_System_Interconnect1) #show interfaces status all | include 0/49
0/49ScaleoutNetwork_InterconnectUp40G FullUnknown Inactive
(SiteN_System_Interconnect1) #show interfaces status all | include 0/51
0/51ScaleoutNetwork_InterconnectUp40G Full40G FullUnknown Active
(SiteN_System_Interconnect1) #exit
(SiteN_System_Interconnect1) >q
Connection closed by foreign host.
```

- e. Create an alias on your laptop to **System Interconnect 2** on the new system:

Note: Do not change the link-local IP address in the command below.

```
sudo ifconfig eth1:0 169.254.210.240 up
```

- f. Connect to **System Interconnect 2** (username: admin, no password):

```
lab@mw-von:~$ telnet 169.254.210.200
Trying 169.254.210.200...
Connected to 169.254.210.200. Escape character is '^]'.
User:admin
Password:
```

- g. Run the following commands:

```
(SiteN_System_Interconnect2) >enable
(SiteN_System_Interconnect2) #configure
(SiteN_System_Interconnect2) (Config)#interface 0/49
(SiteN_System_Interconnect2) (Interface 0/49)#no shutdown
(SiteN_System_Interconnect2) (Interface 0/49)#exit
(SiteN_System_Interconnect2) (Config)#interface 0/51
(SiteN_System_Interconnect2) (Interface 0/51)#no shutdown
(SiteN_System_Interconnect2) (Interface 0/51)#exit
(SiteN_System_Interconnect2) (Config)#exit
(SiteN_System_Interconnect2) #write memory confirm
Config file 'startup-config' created successfully. Configuration Saved!
(SiteN_System_Interconnect2) #show interfaces status all | include 0/49
0/49ScaleoutNetwork_InterconnectUp40G FullUnknown Inactive
(SiteN_System_Interconnect2) #show interfaces status all | include 0/51
0/51ScaleoutNetwork_InterconnectUp40G Full40G FullUnknown Active
(SiteN_System_Interconnect2) #exit
(SiteN_System_Interconnect2) >q
Connection closed by foreign host.
```

6. If necessary, repeat all sub-steps in step 2 on system 3.

6.6 Additional steps for multi-site configurations

If you are scaling out a multi-site configuration, complete these additional steps before running the configuration wizard:

1. Configure the System Interconnects for your chosen uplink mode.

Important: This is an irreversible procedure and must be done by Quantum support running the configuration wizard.

2. Connect transceivers to specific System Interconnect uplink ports depending on your chosen uplink mode, and connect cables from these transceivers to your corresponding network, at each site.

Note: Connect transceivers to ports 52 and 50 on each System Interconnect, on each system, at each site

- For uplink mode 1 (two individual 10G access ports (48,47) per System Interconnect):
 - Connect transceivers to ports 48 and 47 on each System Interconnect, on each system, at each site.
- For uplink mode 2 (one 10G trunk port (48) per System Interconnect):
 - Connect transceivers to port 48 on each System Interconnect, on each system, at each site.
- For uplink mode 3 (one 40G trunk port (50) per System Interconnect):
 - Connect transceivers to port 50 on each System Interconnect, on each system, at each site.
- For uplink mode 4 (three 10G trunk ports (48,47,46) with LACP per System Interconnect):
 - Provide non-conflicting VLAN IDs and configure your respective switch ports for LACP.
 - Connect transceivers to ports 48, 47, and 46 on each System Interconnect, on each system, at each site.
- For uplink mode 5 (two 40G trunk ports (52,50) with LACP per System Interconnect):
 - Provide non-conflicting VLAN IDs and configure your respective switch ports for LACP.
 - Connect transceivers to ports 52 and 50 on each System Interconnect, on each system, at each site.

This completes the hardware setup for scaling out by one additional system.

6.6.1 Software steps

Warning: If your system is running ActiveScale OS 5.0.1, stop. Contact Quantum Support to update the host names of all components on all your systems **before** you follow this procedure.

Before following these steps, complete the hardware steps in the *ActiveScale X100 Installation Guide* at **each site**. You can only scale out incrementally (one new system at a time at each site).

At this point, all nodes in the new system have link local IP addresses and ActiveScale OS pre-installed on them.

Important: The existing system(s) must be in a stable state before scaling out. The scale out job checks data safety levels when it starts. If a system is freshly installed, or if you just completed one scale out, wait 10-15 minutes for the system to stabilize and to update its data safety levels. This is particularly

important if you purchased multiple systems for an initial install. Systems that have been running for some time may report a lowered data safety after a scale out. You must resolve any data safety issues before attempting to scale out. If the data safety of the system is not optimal or there are failed drives, fix the issues by replacing the drives before starting this procedure.

Warning: Components in the new system might have newer firmware than your existing components have. This procedure does not upgrade or downgrade any firmware.

Warning: Do not start a log collection job while a scale out job is running.

1. Start the scale out wizard.

Important: On multi-site deployments, start this wizard from any **one** site. You only need to run it at one site.

- a. In ActiveScale SM click **Configuration > Upgrade**.
- b. In the **System Expansion** section, scroll down to **Scale Out**.
- c. Click **Start**.

Figure 6-138. Starting a scale out

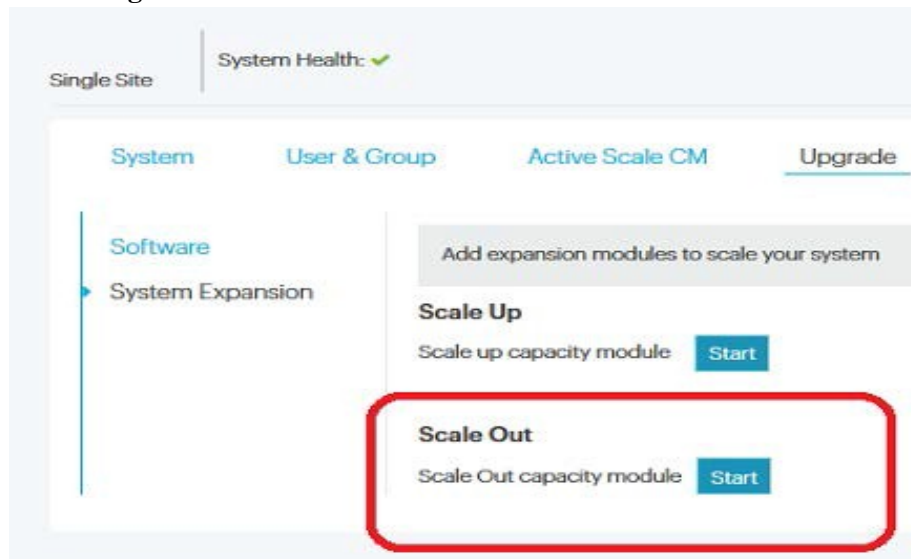

The scale out wizard starts. ActiveScale OS disables the DHCP server on the System Nodes and scans for the new system's link local IP addresses.

Important: Scale out is not allowing you to proceed when the new racks are higher in software version than the old racks

A pop-up appears with results of system scan:

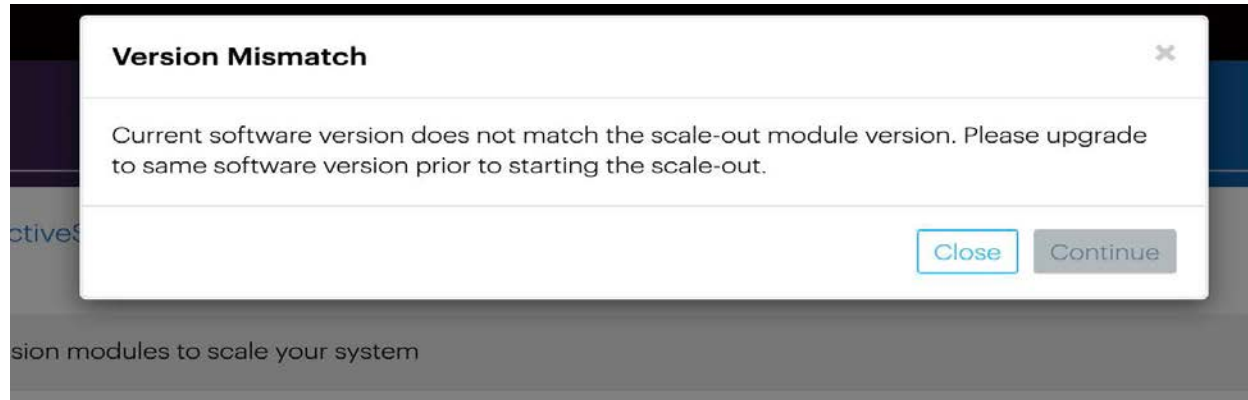
Figure 6-139. Sample pop-up with results of system scan

- If the wizard indicates that no scale out system are available, click **Close**. Check the power-on state and cabling of each component in the new system and start the wizard again.
- If the wizard indicates that there is a version mismatch, click **Close**. Update the ActiveScale OS on the existing system(s) and start the wizard again. For upgrade help, contact Quantum Support.
- If the wizard finds no problems, click **Continue**. The wizard displays the network settings.

Figure 6-140. Scale out: Summary of scan

Scale Out

Multi Site | Site2 (Site2) ① Configur

Site1 (Site1) Site2 (Site2) Site3 (Site3)

VLAN	Network	Netmask	SG1
Public LAN 1	10.11.1.0	255.255.255.0	10.11.1.14
Public LAN 2	10.11.2.0	255.255.255.0	10.11.2.14
Management LAN 1	172.16.110.0	255.255.255.0	
Management LAN 2	172.16.210.0	255.255.255.0	
Storage LAN 1	<input type="text" value="172.16.112.0"/>	<input type="text" value="255.255.255.0"/>	
Storage LAN 2	<input type="text" value="172.16.212.0"/>	<input type="text" value="255.255.255.0"/>	

2. **For each site**, validate the network settings in each tab against your settings as specified in your ActiveScale X100 *Site Survey*, and/or change the Storage Network settings.

Tip: You can change the 4th octet of the new system's Public Network IP addresses and you can change Storage Network addresses. System Network addresses are carried forward from the existing system(s), so you cannot change them.

- Click **Next** to review each tab.

Important: On multi-site deployments, the wizard presents two levels of tabs. **It is critical that you review all the tabs.** In other words, you must review Site 1's network settings in each tab, Site 2's network settings in each tab, and Site 3's network settings in each tab.

- When you reach the last tab, click **Proceed**.

Figure 6-141. Scale out: Click Proceed to apply network settings



The wizard notifies you to check the scale out job on the **Jobs** page.

- Navigate to the **Jobs** page, and wait until the scale out job indicates success or failure.

The **Jobs** page displays the progress of the scale out job. Depending on the size of the system, this job runs for 3 to 18 hours.

Figure 6-142. Scale out: Job progress

Job Type	Job Site	Job Status	Progress	Start Date↓	Duration	Results	Details	Actions
Scale-out		Completed	<div style="width: 100%; background-color: green; height: 10px;"></div> 100%	4/10/18 11:02 PM	4 hrs, 9 mins	Success	i	
Scale-out		Completed	<div style="width: 100%; background-color: green; height: 10px;"></div> 100%	4/10/18 6:34 PM	3 hrs, 50 mins	Success	i	
Scale-out		Completed	<div style="width: 100%; background-color: green; height: 10px;"></div> 100%	4/10/18 2:35 PM	3 hrs, 22 mins	Success	i	
Scale-out		Completed	<div style="width: 100%; background-color: green; height: 10px;"></div> 100%	4/10/18 10:49 AM	3 hrs, 9 mins	Success	i	
Scale-out		Completed	<div style="width: 100%; background-color: green; height: 10px;"></div> 100%	4/9/18 9:48 PM	2 hrs, 46 mins	Success	i	
Scale-out		Completed	<div style="width: 100%; background-color: green; height: 10px;"></div> 100%	4/9/18 6:52 PM	2 hrs, 29 mins	Success	i	

If the scale out job fails, click the icon in its **Details** column to see why it failed and suggestions on how to correct the problem. Follow the suggestions.

If the scale out job succeeds, ActiveScale SM displays a pop-up prompting you to change the `hgstsupport` password for the entire system.

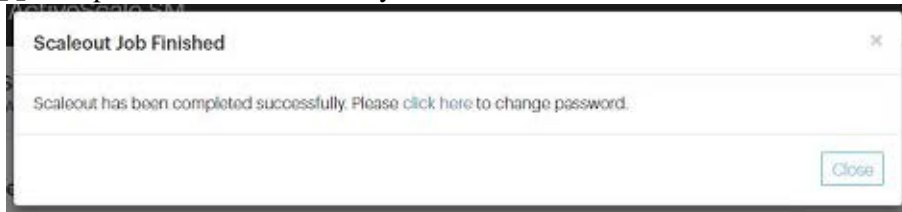

The new system has a different `hgstsupport` password than the existing system(s). Therefore, best practice is to set a common `hgstsupport` password for the entire system.

6. Click the link in the pop-up to start the password wizard.
7. Check the dashboard to confirm that the new system is displayed in the **Resources** tile and that the total capacity of the system is upgraded as expected.

Figure 6-143. Scale Out: Confirmation on dashboard

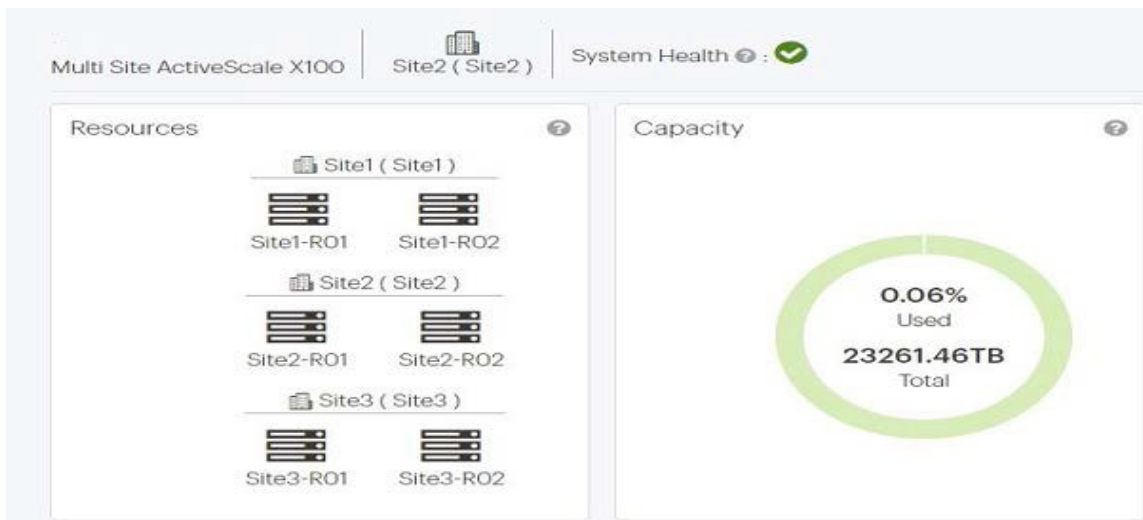

8. Check **Resources** to confirm that the new system's components are displayed with correct host names.

For example, for a multi-site deployment, System Node 3 on the second system at site 1 should have the host name **Site1-R02-SG03**.

Figure 6-144. Scale out: Confirmation on Resources pane



9. Contact support to update the SSH keys on the new system.

At this point, scaling out the system is done.

Tip: If the existing system had encryption enabled, your new system(s) automatically have encryption enabled also.

6.6.2 Post-requisites

On systems with virtual IPs defined, add virtual IPs to the System Nodes on the new system, and add these nodes to the existing failover group. For details, see the *ActiveScale OS Administrator Guide*.

7 Installing rack seal kits

This section provides steps on how to install the rack seal kit.

The rack seal kit (1EX0175) is a hardware upgrade that allows for the rack to be properly sealed in the event that third party liquid cooled doors are installed. The rack seal plate can be easily installed into the bottom of the rack to seal off the rack from air outside of the rack.

The rack seal kit contains the rack seal plate, cage nuts, and screws to securely attach the plate to the rack.

7.1 Installing the rack seal plate



Caution: Some components are heavy.



Caution: Disconnect all power sources before servicing.

Table 7-58. Rack seal plate installation overview

Required tools	Personnel
None	1

To install the rack seal plate:

1. Power the system down.
2. From the rear of the rack, remove the rear fans from the bottom Storage Enclosure Basic.
 - a. From the rear of the chassis, remove the rear fans by pressing the **release button** on the top right of the fan.
 - b. Tilt the top of the fan out until clear of the rubber bumpers attached to the chassis.
 - c. Repeat the previous steps to remove the remaining rear fans.

Figure 7-145. Removing the rear fans

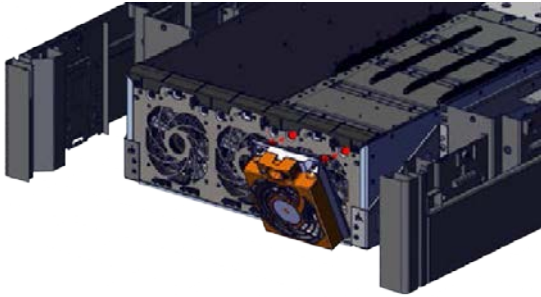

Warning: Do not place fingers anywhere near the fan blades while powered on.

3. On the bottom of the rack, locate the screw holes closest to the rear of the rack.
4. Install a cage nut in each of the two holes. The right side is display in the figure below. The hole on the left side is located directly across from the hole on the right side, in the same position.

Figure 7-146. Rack seal plate cage nuts

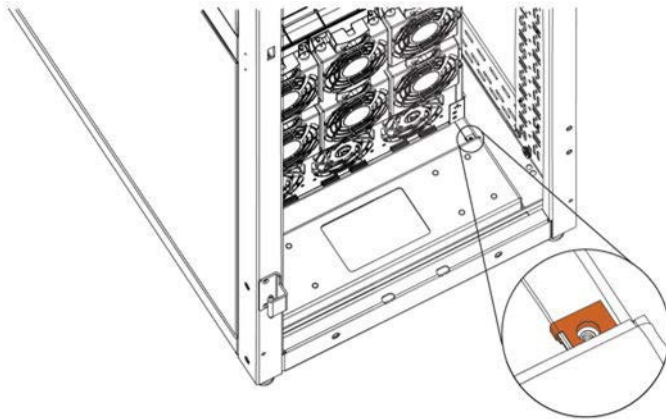

5. From the rear of the rack, install the rack seal plate.
 - a. Place the end of the rack seal plate on the bottom of the rack.

Figure 7-147. Installing the rack seal plate

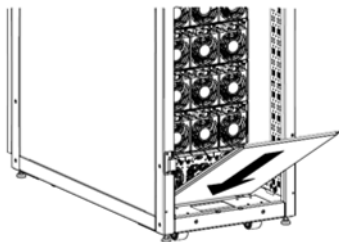

- b. Tip the rack seal plate up slightly to allow the end of the plate to fit under the enclosure.
 - c. Slide the rack seal plate under the bottom enclosure, leveling the plate as it is installed into the rack.

Figure 7-148. Rack seal plate installed

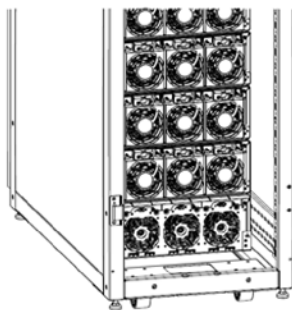

6. Using a #2 Phillips screwdriver, attach the rack seal plate to the holes with the cage nuts with the M5 screws.
7. From the rear of the rack, reinstall the rear fans on the bottom Storage Enclosure Basic.
 - a. From the rear of the chassis, place the bottom of the fan on the rubber bumpers on the chassis.

Warning: Do not place fingers anywhere near the fan blades while powered on.

- b. Tilt the top of the fan inward until the top of the fan is seated into the chassis.
- c. Repeat the previous steps to install the remaining rear fans.

Figure 7-149. Installing the rear fans

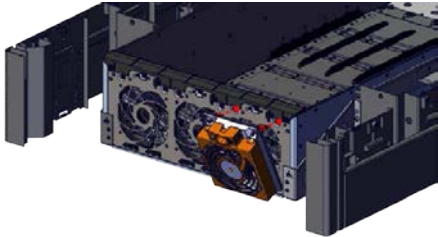

8. From ActiveScale™ X100 SM, power on the system.

8 Installing System Expansion Node kits

System Expansion Node kits provide one additional System Node for your ActiveScale system. Additional System Nodes allow you to increase system performance with your current storage capacity. You can add up to three System Expansion Node kits (three additional System Nodes) to each ActiveScale X100 base system. Multi-site deployments can support up to 21 System Expansion Nodes.

System Expansion Node kits are supported with other upgrades, this includes:

- Scale out deployments
- Scale up deployments
- Multi-site deployments

Important: System Expansion Node kits do not provide failover or high-availability capabilities to ActiveScale systems.

8.1 System Expansion Node kit requirements

Before purchasing a System Expansion Node kit, ensure that your ActiveScale X100 system meets the requirements in this section.

8.1.1 Public Network IP address requirements

System Expansion Nodes in the same local rack must be in the same subnet.

8.1.2 Multi-site deployment requirements

There is no requirement to mirror System Expansion Nodes across multi-site deployments. For example, you can install System Expansion Node kits in a single rack in a multi-site deployment without issue.

8.1.3 Rack requirements

Ensure that your rack can meet the additional requirements for each added System Expansion Node:

- 1U rack space
- 27 lbs (12.2 kg) of additional weight
- 0.665 at 785 KBTU/hour of additional thermal output
- 230 W of additional power

8.1.4 PDU requirements

Each System Expansion Node consumes approximately of additional power. Ensure that the PDUs in the system can support the additional power load for each kit.

8.1.4.1 PDU requirements for Racked systems

If your system is using one of the following power options, an additional PDU is required:

- (United States only) NEMA L21-30p plug, 3 phase delta, 208V 30A
- (United States only) NEMA L15-30p plug, 3 phase delta, 208V 30A

In these cases, contact Quantum Corporation support.

8.2 Unpacking System Expansion Node kits

Table 8-1. Kit contents

Part	Contents
System Expansion Node kit Part number - 1EX1256	<ul style="list-style-type: none">• One System Node• One 1U System Node mounting kit• System Node power cables• Two 10G SFP+ 1M DAC cables• Two 10G SFP+ SR Optic transceivers

To unpack the System Expansion Node kits:

1. Remove the cables and mounting kit.
2. Remove the System Expansion Node.
3. Inspect each item in the box for damage.

Repeat this process for each System Expansion Node kit.

8.3 Installing System Expansion Node kits

System Nodes and System Expansion Nodes use the same installation procedure. Starting from the lowest U-space above the existing equipment, the install System Expansion Nodes from bottom to top.

Figure 8-1. System Expansion Node rack locations

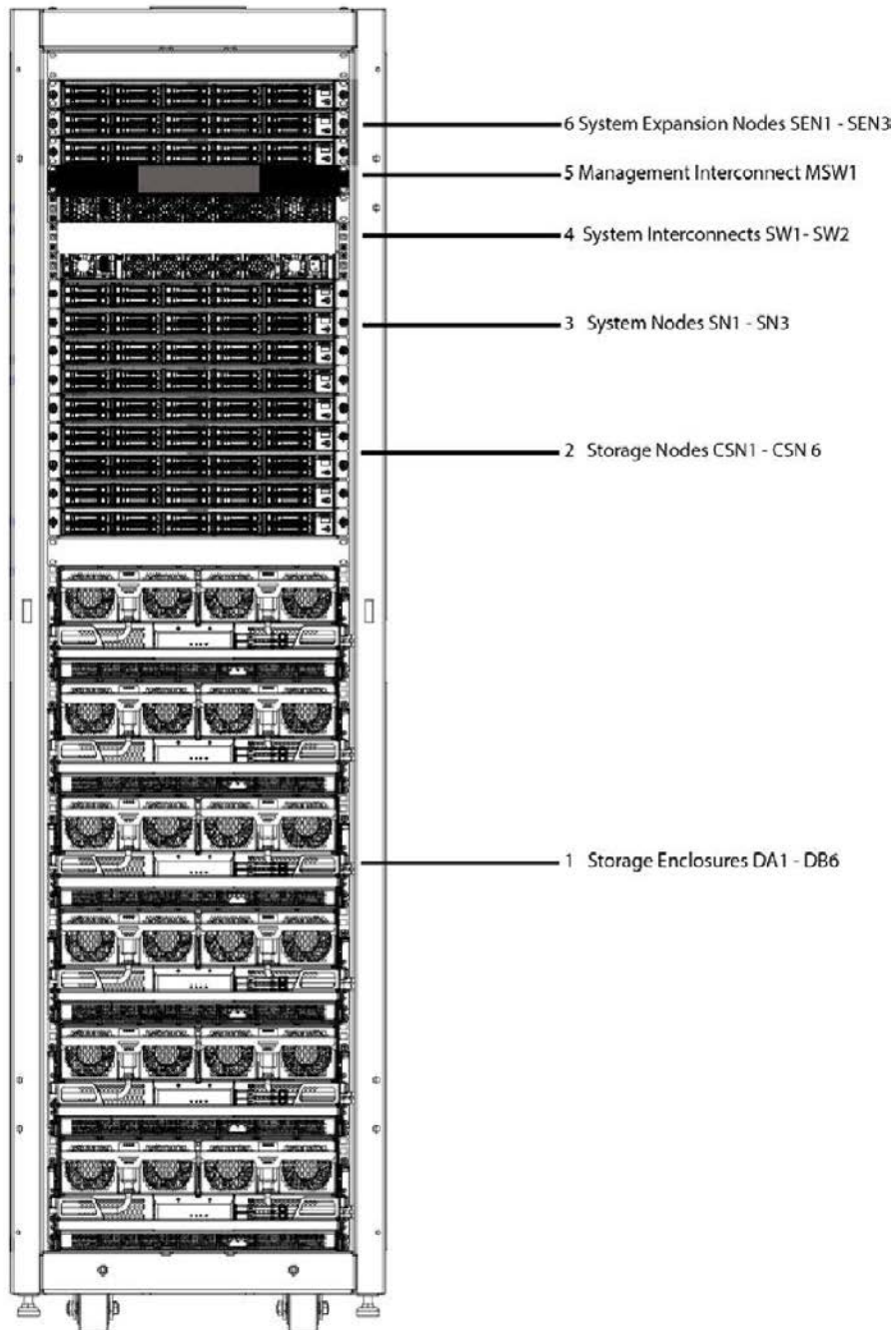

8.3.1 Installing the 1U rail kit

To install the rails for the System Expansion Node:

1. Attach the outer rails to the rack.

Note: Verify that you are installing the correct rail on each side of the rack. The rear of each rail is marked with “rear”.

- a. Extend the outer rail enough that it extends between the two vertical rails of the rack.

Figure 8-2. Expand the outer Rail

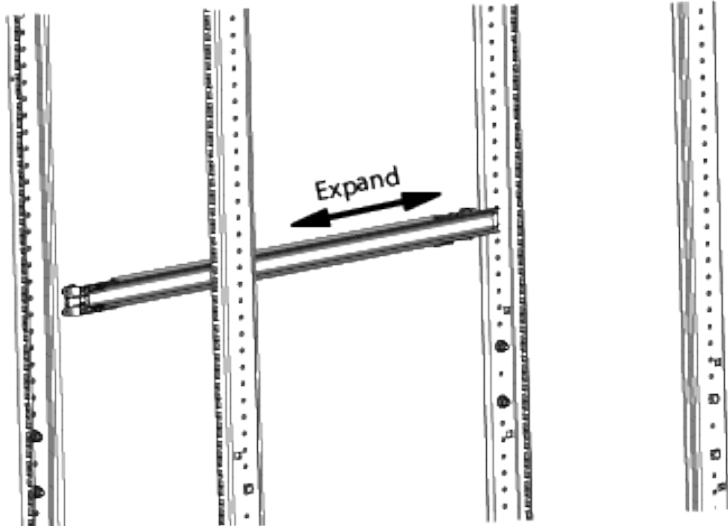

- b. Position the hook on the rear outer rail around the rear vertical rail.
- c. Slide the rear outer rail pegs into the desired slots.
- d. Position the hook on the rear outer rail over the rear vertical rail and then slide the rear outer rail pegs into the desired slots. The clip at the rear of the rail kit is installed over the rack rail to hold it in place.

Figure 8-3. Rail attaching to rear vertical rail



- e. Extend the outer rail forward and insert the pegs into the front vertical rail.

Figure 8-4. Rail attaching to front vertical rail



- f. Extend the inner rail to its full length.
- g. Remove the inner rail by sliding the white clip with a rounded edge forward.

Note: Be cautious leaving the outer rails extending out of the rack. Consider pushing the outer rails back until you are ready to install the node.

- h. Repeat the previous steps to attach the other rail to the rack.
2. Attach the inner rails to the node.
- a. Align the holes in the inner rail with the pegs on the side of the node.
 - b. Slide the rail forward to lock it in place.

Figure 8-5. Locking the inner rail to the node

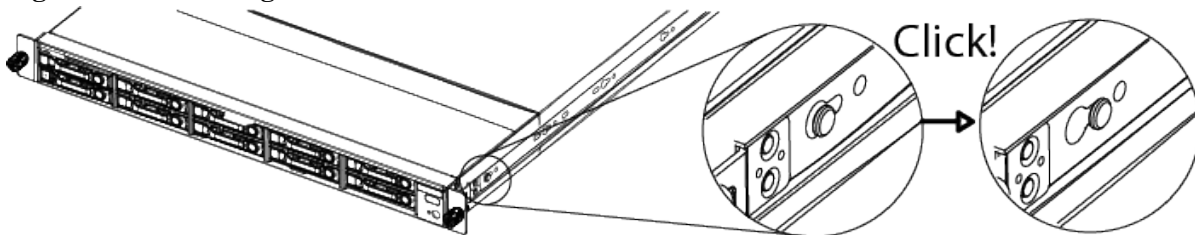

- c. Secure the inner rail to the node using one of the screws.

Repeat these steps to attach the second rail.

8.3.2 Installing a System Expansion Node into the rack

Important: Install components into the rack from bottom to top.

Important: The System Expansion Node weighs 27 lbs (12.2 kg), take precautions when lifting.

To install a System Expansion Node:

1. Re-extend the outer rails from the rack.
2. Align the rails on the node to the rails attached to the rack
3. Push the node into the rack. On the sides of the rail, pull the blue tabs forward to allow the inner rail to slide all the way in.
4. With the node inserted fully into the rack, screw the thumb screws on the front of the system into the node.

Repeat these steps to install all of the System Expansion Nodes.

Important: You can install all of the System Expansion Nodes into the rack at once. However, the nodes must be powered on and configured one at a time.

8.4 Connecting the System Expansion Node kit networking cables

Use the tables in this section to cable each System Expansion Node.

Table 8-2. System Interconnect connections for the System Expansion Nodes

Local device	Local port	Peer port	Peer device	Cable
System Expansion Node 3	N2	N42	SW2	10G SFP+ 1M DAC
	N4	N42	SW1	
System Expansion Node 2	N2	N40	SW2	
	N4	N40	SW1	
System Expansion Node 1	N2	N38	SW2	
	N4	N38	SW1	

Table 8-3. Management Interconnect connections for the System Expansion Nodes

Local device	Local port	Peer port	Peer device	Cable
System Expansion Node 3	M5	15	MSW	RJ45 1 M CAT5e
System Expansion Node 2		14		
System Expansion Node 1		13		

8.5 Installing System Expansion Node kits in multi-site systems

A multi-site system can support up to 21 System Expansion Nodes. System Expansion Nodes do not need to be mirrored across multiple sites.

Table 8-4. Multi-site example configuration

Rack	System Expansion Nodes per ActiveScale X100 system
Primary rack	3
Scale out rack 1	3
Scale out rack 2	3
Scale out rack 3	3
Scale out rack 4	3
Scale out rack 5	2
Scale out rack 6	1
Scale out rack 7	1
Scale out rack 8	2
	21 total

Important: If you are installing System Expansion Nodes in multiple racks, install all of the kits in a single rack before moving on to the next rack.

8.6 Installing the System Expansion Node PDU kit

Important: To determine if you need to install a third PDU, refer to [Installing System Expansion Node kits](#) on page 168.

To install a third PDU into an ActiveScale X100 system:

1. From the rear of the rack, feed the plug through the opening in the top of the rack. Ensure the plug is draped over the rack in a safe location and will not fall back through the hole.

Note: The PDU cables may also go through the bottom of the rack if the power source is below the rack.

2. Line up the PDU over the mounting holes.
3. Place the mounting pegs over the rack PDU mounting points and pull down.

Figure 8-6. Installing a three-phase PDU

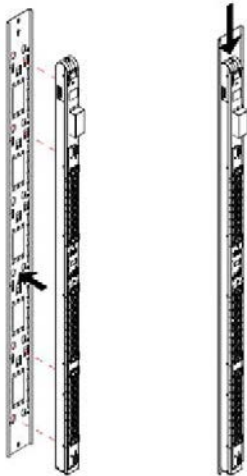

4. Secure the PDUs to the rack.

8.6.1 Re-balancing the PDUs

Important: This section assumes that the power running into the PDUs is properly balanced in your data center's power grid, and can balance the load over the PDUs in case of PDU failure.

The tables in this section describe how components should be plugged into the PDUs after installing System Expansion Node kits.

Note: Plug Storage Enclosure Basics and their corresponding Storage Nodes into the same segment of the PDU.

8.6.1.1 Three-phase across two PDUs

Table 8-5. Three-phase across two PDUs - PDUs 1 and 2

Branch ZX				
Plug	Current (A)	Component	Port	Time on (s)
C-13	1.16	System Expansion Node 3	28	30
C-13	1.15	Storage Node 6	27	60
C-13	1.15	Storage Node 5	26	50
C-13	4.3	Storage Enclosure Basic 6	25	40
C-13	1.16	System Node 3	24	20
C-13	4.3	Storage Enclosure Basic 5	23	10
C-13	1.06	System Interconnect 2	22	0
	14.28 Total			
Branch YZ				
Plug	Current (A)	Component	Port	Time on (s)
C-13	1.16	System Expansion Node 2	19	30
5-13	1.15	Storage Node 4	17	60
C-13	1.15	Storage Node 3	16	50
C-13	4.3	Storage Enclosure Basic 4	15	40
C-13	1.16	System Node 2	18	20
C-13	4.3	Storage Enclosure Basic 3	13	10
C-13	1.06	System Interconnect 1	12	0
	13.32 Total			
Branch XY				
Plug	Current (A)	Component	Port	Time on (s)
C-13	1.16	System Expansion Node 1	8	30
C-13	1.15	Storage Node 2	7	60
C-13	4.3	Storage Enclosure Basic 2	6	50
C-13	1.15	Storage Node 1	5	40
C-13	4.3	System Expansion Node 1	4	20
C-13	1.16	System Node 1	3	10
C-13	0.1	Management Interconnect ¹	2	0
	13.32 Total			

1.PDU 1 only.

8.6.1.2 Three-phase across three PDUs

Table 8-6. Three-phase across three PDUs - PDU 1

Branch ZX				
Plug	Current (A)	Component	Port	Time on (s)
C-13	2.02	System Expansion Node 3	28	30
C-13	1.15	Storage Node 6	27	60
C-13	4.3	Storage Enclosure Basic 6	25	40
C-13	1.16	System Node 3	24	20
C-13	1.06	System Interconnect 2	22	0
	9.69 Total			
Branch YZ				
Plug	Current (A)	Component	Port	Time on (s)
C-13	2.02	System Expansion Node 2	19	30
C-13	1.15	Storage Node 3	16	50
C-13	1.16	System Node 2	18	20
C-13	4.3	Storage Enclosure Basic 3	13	10
C-13	1.06	System Interconnect 1	12	0
	9.69 Total			
Branch XY				
Plug	Current (A)	Component	Port	Time on (s)
C-13	1.15	Storage Node 2	7	60
C-13	4.3	Storage Enclosure Basic 2	6	50
C-13	1.15	Storage Node 1	5	40
C-13	4.3	Storage Enclosure Basic 1	4	20
	10.9 Total			

Table 8-7. Three-phase across three PDUs - PDU 2

Branch ZX				
Plug	Current (A)	Component	Port	Time on (s)
C-13	1.15	Storage Node 6	27	60
C-13	1.15	Storage Node 5	26	50
C-13	4.3	Storage Enclosure Basic 6	25	40
C-13	4.3	Storage Enclosure Basic 5	23	10
	10.9 Total			
Branch YZ				
Plug	Current (A)	Component	Port	Time on (s)
C-13	2.02	System Expansion Node 2	19	30
C-13	1.15	Storage Node 4	17	60

C-13	4.3	Storage Enclosure Basic 4	15	40
C-13	2.02	System Node 2	18	20
C-13	1.06	System Interconnect 1	12	0
	10.55 Total			
Branch XY				
Plug	Current (A)	Component	Port	Time on (s)
C-13	2.02	System Expansion Node 1	8	30
C-13	1.15	Storage Node 1	5	40
C-13	4.3	Storage Enclosure Basic 1	4	20
C-13	1.16	System Node 1	3	10
C-13	0.1	Management Switch	2	0
	8.73 Total			

Table 8-8. Three-phase across three PDUs - PDU 3

Branch ZX				
Plug	Current (A)	Component	Port	Time on (s)
C-13	2.02	System Expansion Node 3	28	30
C-13	1.15	Storage Node 5	26	50
C-13	1.16	System Node 3	24	20
C-13	4.3	Storage Enclosure Basic 5	23	10
C-13	1.06	System Interconnect 2	22	0
	9.69 Total			
Branch YZ				
Plug	Current (A)	Component	Port	Time on (s)
C-13	1.15	Storage Node 4	17	60
C-13	1.15	Storage Node 3	16	50
C-13	4.3	Storage Enclosure Basic 4	15	40
C-13	4.3	Storage Enclosure Basic 3	13	10
	10.9 Total			
Branch XY				
Plug	Current (A)	Component	Port	Time on (s)
C-13	2.02	System Expansion Node 1	8	30
C-13	1.15	Storage Node 2	7	60
C-13	4.3	Storage Enclosure Basic 2	6	50
C-13	1.16	System Node 1	3	10
	9.69 Total			

8.6.2 Programming the PDUs

PDU reprogramming is done using the PDU firmware CLI. You can access the CLI using one of the following methods:

- A serial (RS232) port
- An Ethernet port

8.6.2.1 Connecting to the PDU with a serial port

The PDU has an RJ45 serial RS-232 port. Use a RJ45-to-DB9F serial port adapter to connect using a PC or networked terminal server.

Serial port connections require either a terminal or terminal emulation software configured to support VT100/ANSI. The serial port also requires the following settings:

- Baud: **9600**
- Data Bits: **8**
- Parity: **None**
- Stop Bits: **1**
- Flow Control: **None**

8.6.2.2 Connecting to the PDU with an Ethernet port

The PDU is also equipped with an RJ45 10/100Base-T Ethernet port. Use this connection to access the PDU firmware CLI with Telnet.

The PDU Ethernet port uses the following default settings:

- IP Address: **192.168.1.254**
- Subnet Mask: **255.255.255.0**
- Gateway: **192.168.1.1**

Configure a PC Ethernet port with a static IP address in the range 192.168.1.2-253 to enable communication with the PDU Ethernet port.

Use the PDU IP address when initiating the Telnet session:

```
telnet 192.168.1.254
```

8.6.2.3 Logging into the PDU Firmware CLI

After connecting to the PDU firmware CLI, use the following credentials to log in:

- **Username:** admn
- **Password:** admn

After logging in, input the relevant commands for your PDU.

8.6.2.4 Three-phase PDU programming with three PDUs

- PDU 1

```
show system
show units
set unit name A PDU-1
set access prompt Switched CDU:
set outlet name AA1 UNUSED1
set outlet name AA2 UNUSED2
set outlet name AA3 UNUSED3
set outlet name AA4 JBOD1
set outlet name AA5 CSN1
set outlet name AA6 JBOD2
set outlet name AA7 CSN2
set outlet name AA8 UNUSED8
set outlet name AA9 UNUSED9
set outlet name AA10 UNUSED10
set outlet name AA11 UNUSED11
set outlet name AA12 TORSW1
set outlet name AA13 JBOD3
set outlet name AA14 UNUSED14
set outlet name AA15 UNUSED15
set outlet name AA16 CSN3
set outlet name AA17 UNUSED17
set outlet name AA18 SN2
set outlet name AA19 SEN2
set outlet name AA20 UNUSED20
set outlet name AA21 UNUSED21
set outlet name AA22 TORSW2
set outlet name AA23 UNUSED23
set outlet name AA24 SN3
set outlet name AA25 JBOD6
set outlet name AA26 UNUSED26
set outlet name AA27 CSN6
set outlet name AA28 SEN3
set outlet name AA29 UNUSED29
set outlet name AA30 UNUSED30
set outlet extondelay AA1 0
set outlet extondelay AA2 0
set outlet extondelay AA3 0
set outlet extondelay AA4 20
set outlet extondelay AA5 40
set outlet extondelay AA6 50
set outlet extondelay AA7 60
set outlet extondelay AA8 0
set outlet extondelay AA9 0
set outlet extondelay AA10 0
set outlet extondelay AA11 0
set outlet extondelay AA12 0
set outlet extondelay AA13 10
```

```
set outlet extondelay AA14 0
set outlet extondelay AA15 0
set outlet extondelay AA16 50
set outlet extondelay AA17 0
set outlet extondelay AA18 20
set outlet extondelay AA19 30
set outlet extondelay AA20 0
set outlet extondelay AA21 0
set outlet extondelay AA22 0
set outlet extondelay AA23 0
set outlet extondelay AA24 20
set outlet extondelay AA25 40
set outlet extondelay AA26 0
set outlet extondelay AA27 60
set outlet extondelay AA28 30
set outlet extondelay AA29 0
set outlet extondelay AA30 0
set outlet seqdelay 0
set dhcp staticfallback disabled
reboot ALL
```

- PDU 2

```
show system
show units
set unit name A PDU-2
set access prompt Switched CDU:
set outlet name AA1 UNUSED1
set outlet name AA2 MSW
set outlet name AA3 SN1
set outlet name AA4 JBOD1
set outlet name AA5 CSN1
set outlet name AA6 UNUSED6
set outlet name AA7 UNUSED7
set outlet name AA8 SEN1
set outlet name AA9 UNUSED9
set outlet name AA10 UNUSED10
set outlet name AA11 UNUSED11
set outlet name AA12 TORSW1
set outlet name AA13 UNUSED13
set outlet name AA14 UNUSED14
set outlet name AA15 JBOD4
set outlet name AA16 UNUSED16
set outlet name AA17 CSN4
set outlet name AA18 SN2
set outlet name AA19 SEN2
set outlet name AA20 UNUSED20
set outlet name AA21 UNUSED21
set outlet name AA22 UNUSED22
set outlet name AA23 JBOD5
set outlet name AA24 UNUSED24
```

```
set outlet name AA25 JBOD6
set outlet name AA26 CSN5
set outlet name AA27 CSN6
set outlet name AA28 UNUSED28
set outlet name AA29 UNUSED29
set outlet name AA30 UNUSED30
set outlet extondelay AA1 0
set outlet extondelay AA2 0
set outlet extondelay AA3 10
set outlet extondelay AA4 20
set outlet extondelay AA5 40
set outlet extondelay AA6 0
set outlet extondelay AA7 0
set outlet extondelay AA8 30
set outlet extondelay AA9 0
set outlet extondelay AA10 0
set outlet extondelay AA11 0
set outlet extondelay AA12 0
set outlet extondelay AA13 0
set outlet extondelay AA14 0
set outlet extondelay AA15 40
set outlet extondelay AA16 0
set outlet extondelay AA17 60
set outlet extondelay AA18 20
set outlet extondelay AA19 30
set outlet extondelay AA20 0
set outlet extondelay AA21 0
set outlet extondelay AA22 0
set outlet extondelay AA23 10
set outlet extondelay AA24 0
set outlet extondelay AA25 40
set outlet extondelay AA26 50
set outlet extondelay AA27 60
set outlet extondelay AA28 0
set outlet extondelay AA29 0
set outlet extondelay AA30 0
set outlet seqdelay 0
set dhcp staticfallback disabled
reboot ALL
```

- PDU 3

```
show system
show units
set unit name A PDU-3
set access prompt Switched CDU:
set outlet name AA1 UNUSED1
set outlet name AA2 UNUSED2
set outlet name AA3 SN1
set outlet name AA4 UNUSED4
set outlet name AA5 UNUSED5
```

```
set outlet name AA6 JBOD2
set outlet name AA7 CSN2
set outlet name AA8 SEN1
set outlet name AA9 UNUSED9
set outlet name AA10 UNUSED10
set outlet name AA11 UNUSED11
set outlet name AA12 UNUSED12
set outlet name AA13 JBOD3
set outlet name AA14 UNUSED14
set outlet name AA15 JBOD4
set outlet name AA16 CSN3
set outlet name AA17 CSN4
set outlet name AA18 UNUSED18
set outlet name AA19 UNUSED19
set outlet name AA20 UNUSED20
set outlet name AA21 UNUSED21
set outlet name AA22 SW2
set outlet name AA23 JBOD5
set outlet name AA24 SN3
set outlet name AA25 UNUSED25
set outlet name AA26 CSN5
set outlet name AA27 UNUSED27
set outlet name AA28 SEN3
set outlet name AA29 UNUSED29
set outlet name AA30 UNUSED30
set outlet extondelay AA1 0
set outlet extondelay AA2 0
set outlet extondelay AA3 10
set outlet extondelay AA4 0
set outlet extondelay AA5 0
set outlet extondelay AA6 50
set outlet extondelay AA7 60
set outlet extondelay AA8 30
set outlet extondelay AA9 0
set outlet extondelay AA10 0
set outlet extondelay AA11 0
set outlet extondelay AA12 0
set outlet extondelay AA13 10
set outlet extondelay AA14 0
set outlet extondelay AA15 40
set outlet extondelay AA16 50
set outlet extondelay AA17 60
set outlet extondelay AA18 0
set outlet extondelay AA19 0
set outlet extondelay AA20 0
set outlet extondelay AA21 0
set outlet extondelay AA22 0
set outlet extondelay AA23 10
set outlet extondelay AA24 20
set outlet extondelay AA25 0
```



```
set outlet extondelay AA26 50
set outlet extondelay AA27 0
set outlet extondelay AA28 30
set outlet extondelay AA29 0
set outlet extondelay AA30 0
set outlet seqdelay 0
set dhcp staticfallback disabled
reboot ALL
```

8.7 Programming the System Interconnects

After cabling the System Expansion Nodes, log into the System Interconnect and open ports 38 (for System Expansion Node 1), 40 (for System Expansion Node 2) and 42 (for System Expansion Node 3).

Note: The VLANs on each port will be automatically enabled while running the System Expansion Node configuration wizard.

To program each System Interconnect:

1. Connect an Ethernet cable from your laptop to port 44 on System Interconnect 1.
2. Configure your computer to be on the same network as the System Interconnect using the following values:
 - Management Port: 192.168.123.0/24
 - Subnet: 255.255.255.0
 - Gateway: 192.168.123.123
3. Open a Telnet session to the System Interconnect and replace *switchport_IP* with the default IP address 192.168.123.123.

The System Interconnect command prompt appears.

4. Log in using the default credentials:
 - **User name:** admin
 - no password
5. Type `enable` to enter the Privileged EXEC command mode.

```
(Routing)>enable
```

6. Type `configure` to enter the Privileged CONF command mode.

```
(Routing)#configure
(Routing) (Config)#
```

7. Open the required ports for the System Expansion Node:

Important: If you are installing more than one System Expansion Node, open the necessary ports on both System Interconnects before continuing to the next node.

- a. System Expansion Node 1

```
en
conf

interface 0/38
no shutdown
exit

exit

write memory confirm

Config file 'startup-config' created successfully. Configuration Saved!
```

b. System Expansion Node 2

```
en
conf

interface 0/40
no shutdown
exit

exit

write memory confirm

Config file 'startup-config' created successfully. Configuration Saved!
```

c. System Expansion Node 3

```
en
conf

interface 0/42
no shutdown
exit

exit

write memory confirm

Config file 'startup-config' created successfully. Configuration Saved!
```

Repeat steps 1-7 to open the ports on System Interconnect 2.

If the management switch needs to be updated, contact Quantum technical support.

8.8 Powering on the System Expansion Node

Power on the System Expansion Node using the front power button.

Important: If you are installing more than one System Node, only power on one System Expansion Node at a time, then run the system expansion wizard for that node. Repeat these steps for each System Expansion Node.

8.9 Software steps for adding a System Expansion Node kit

Before following these steps, complete the hardware steps in the *ActiveScale X100 Installation Guide*. You can add one new System Expansion Node at a time to only one system at any one site.

At this point, all nodes in the new system have link local IP addresses and ActiveScale OS pre-installed on them.

Warning: Components in the System Expansion Node might have newer firmware than your existing components have. This procedure does not upgrade or downgrade any firmware.

Warning: Do not start a log collection job while a System Expansion Node job is running.

1. Start the system expansion wizard.

Important: On multi-site deployments, log into the GUI from the on each sites System Node to initiate the wizard.

- d. In the **System Expansion** section, scroll down to **System Node**.
- e. Click **System node**.

Figure 8-7. Starting a System Expansion Node job

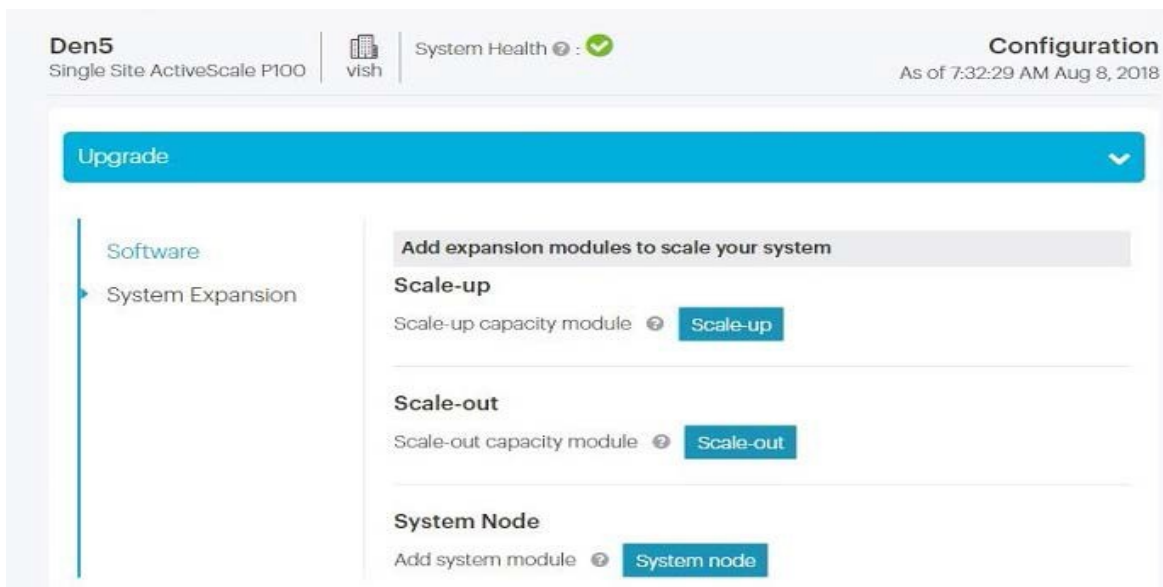

- f. Select the system which the new System Expansion Node is attached to, and click **Next**.

Figure 8-8. Selecting which system the new System Expansion Node is attached to

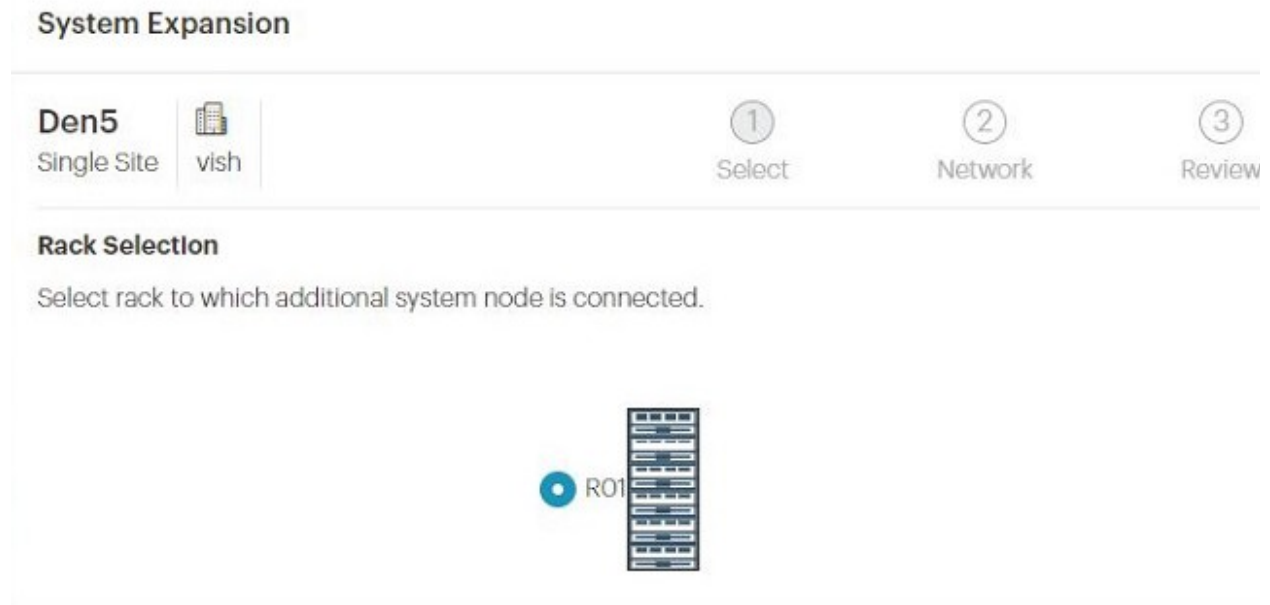





The System Expansion Node wizard starts. ActiveScale OS disables the DHCP server on the System Nodes and scans for the new System Expansion Node's link local IP addresses.

- If the wizard indicates that no System Expansion Nodes are available, click **Close**. Check the power-on state and cabling of the System Expansion Node and start the wizard again.
- If the wizard finds no problems, click **Continue**. The wizard displays the network settings.

Figure 8-9. System Expansion Node: Summary of scan

System Expansion

Den5  vish  Select  Network  Review

VLAN	Network	Netmask	SG4
Public Network 1	192.168.0.0	255.255.192.0	192.168.41. 44
Public Network 2	192.168.64.0	255.255.192.0	192.168.111. 44
Management Network 1	172.16.110.0	255.255.255.0	
Management Network 2	172.16.210.0	255.255.255.0	

2. **For each site**, validate the network settings in each tab against your settings as specified in your *ActiveScale X100 Site Survey*, and/or change the Storage Network settings.

Tip: You can change the 4th octet of the new system's Public Network IP addresses. System Network addresses are carried forward from the existing system(s), so you cannot change them.

3. Click **Next** to review inputs.

Important: On multi-site deployments, the wizard presents two levels of tabs. **It is critical that you review all the details.** In other words, you must review Site 1's network settings in each tab, Site 2's network settings in each tab, and Site 3's network settings in each tab.

4. When you reach the last tab, click **Proceed**.

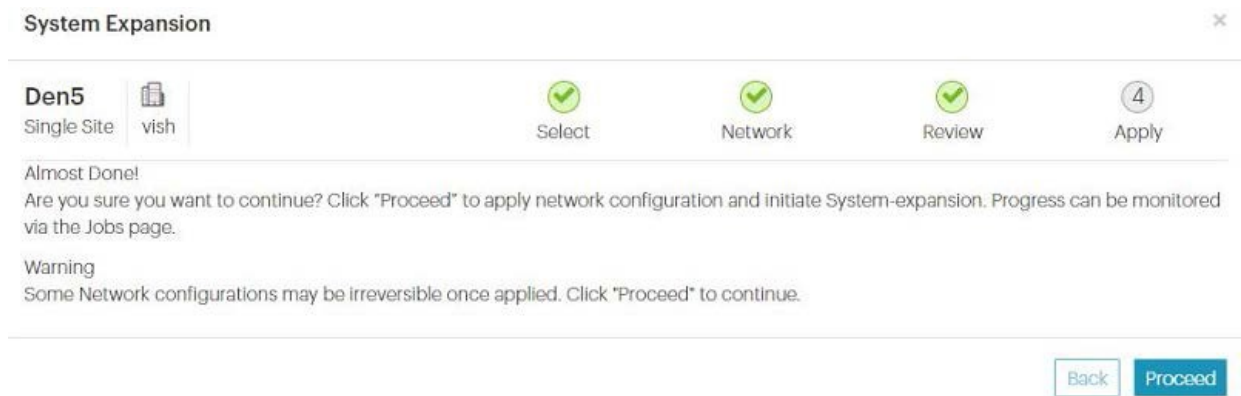
Figure 8-10. System Expansion Node: Click Proceed to apply network settings

The wizard notifies you to check the System Expansion job on the **Jobs** page.

5. Navigate to the **Jobs** page, and wait until the System Expansion job indicates success or failure.

The **Jobs** page displays the progress of the System Expansion job.

Figure 8-11. System Expansion Node: Job progress

Job Type	Job Site	Job Status	Progress	Start Date	Duration	Results	Details	Actions
System Expansion	vish	In Progress	10%	8/8/2018 7:42 AM	1 min	In Progress		
Upgrade	vish	Completed	100%	8/7/2018 10:20 AM	2 hrs, 28 mins	Success		
Upload Upgrade Image	vish	Completed	100%	8/7/2018 10:18 AM	1 min	Success		
Log Archival	vish	Completed	N/A	8/6/2018 10:46 AM	2 mins	Success		

If the System Expansion Node job fails, click the icon in its **Details** column to see why it failed and suggestions on how to correct the problem. Follow the suggestions.

If the System Expansion Node job succeeds, the **Results** column changes from **In-Progress** to **Success**.

Figure 8-12. System Expansion Node: Job success

Job Type	Job Site	Job Status	Progress	Start Date	Duration	Results	Details	Actions
System Expansion	vish	Completed	100%	8/8/2018 7:42 AM	53 mins	Success	i	
Upgrade	vish	Completed	100%	8/7/2018 10:20 AM	2 hrs, 28 mins	Success	i	
Upload Upgrade Image	vish	Completed	100%	8/7/2018 10:18 AM	1 min	Success	i	
Log Archival	vish	Completed	N/A	8/6/2018 10:46 AM	2 mins	Success	i	

- Log out of the GUI and log back in to see the new system node and check the dashboard to confirm that the new system node is displayed in the **Resources** tile with the correct name.

For example, for a multi-site deployment, System Expansion Node 3 on the second system at site 1 should have the host name **Site1-R02-SEN03**.

Figure 8-13. System Expansion Node: Confirmation on dashboard

Den5
Single Site ActiveScale P100 | vish | System Health ✔ | **Resources**
As of 8:38:08 AM Aug 8, 2018

vish | Action ▾

Serial Number: USCSJ01517DA9995 | Hardware Failures:

R01

System Node: Site1-R01-SG04 | Action ▾

Status: Online | Serial: QTFCOU630002B

Selected: SSD

SSDs: [SSD] [SSD] [SSD] [SSD] [SSD]

HDDs: [32°C] [32°C] [32°C] [33°C]

Fans: [Fan] [Fan] [Fan] [Fan] [Fan] [Fan]

PSUs: [PSU] [PSU]

NICs: [NIC] [NIC] [NIC] [NIC]

Status: ONLINE
Size: 44713 GB
Serial: SDF1DAR-480G-1JA2_A01450 AD

Figure 8-14. System Expansion Node: Confirmation on Resources pane

7. If you are using NFS client failover, assign a virtual IP address to the new System Expansion Node. For more information, see the *ActiveScale OS Administrator Guide*.

You have now completed the addition of the System Expansion Node.

9 Re-racking a system

This section describes how to transfer an ActiveScale X100 system into a different rack.

9.1 Warnings and cautions

Warning: Failure to follow the guidelines in this section can cause serious issues or additional system downtime.

Important: Quantum Corporation recommends completing this procedure under the guidance of Quantum Corporation customer support.

When re-racking a system:

- Install and cable components one at a time. Use the cable labels to ensure that the cabling is correct.

Important: When cabling, system components are NOT interchangeable. For example, do not cable the sixth Storage Node to the fourth Storage Enclosure Basic.

- Install components in the order and location directed.
- Before powering the system back on, ensure that all components are:
 - Cabled correctly
 - Installed in the correct U-locations

After the installation is complete, it is the installer's responsibility to ensure that proper cooling is supplied to the new rack. Use the [System specification summary](#) on page 228 to confirm that the new system is within recommended operating parameters.

9.2 Rack Requirements

Ensure that your new rack can meet the following requirements:

- **System depth**—Select a rack mounting solution that has a depth of 47.24 in (1200 mm).
- **System height**—Select a rack that can support 38U.
- **System weight**—Select a rack that can maintain a static load of 2000 lbs (907.18 kg)
- **Rack rails**—Select a rack with rails that are either:
 - Set 798 mm from the front of the rack to the mounting surface.
 - Back far enough to allow space for the molding of the power cords of the Storage Enclosure Basics to go between or around the front vertical rails.
- **Cabling and cable management**—Select a cable management system that can route cables safely through your system. Use the following guidelines:
 - Cables are wired from the rear of the system. In the case of the storage enclosures, the cables connect in the front of the rack and are run through cabling channels in the rail kit to the rear of the rack.
 - All cables provided are varying lengths based on the design of the whole system. The length of each cable is based on the length needed to cleanly connect to the necessary component ports.
 - There is a maximum supported length of seven meters for the DAC cables used in the ActiveScale X100.

- **Grounding**—Ensure that the electrical components used to power the system can be grounded safely.
- **Component dimensions**—Select a rack that can meet the dimensions for each system component. For the full set of dimensions for each component, refer to [System specifications](#) on page 227.

9.2.1 PDU requirements

If you are not using the PDUs that came with your ActiveScale X100 after re-racking the system, follow the PDU requirements in this section.

Table 9-9. System Power Requirements

Parameter	Minimum Configuration	Full Configuration
Power Connector Type	All connectors on each component are C14. The system comes with C13 to C14 cables. If these cables are not compatible with the site's selected PDU and power equipment, the user must provide compatible cables.	
Number of Connectors	35	35
Nominal System Power Required (W)	2.90 kW	6.50 kW
Maximum System Power Required (W)	4.0 kW	7.60 kW

Table 9-10. Component Power Measurements

Component	Average Active Power	Maximum Active Power
Management Interconnect	9 W	9 W
System Interconnect	83 W	85 W
System Node	196 W	228 W
Storage Node	200 W	229 W
Storage Enclosure Basic	804 W	873 W

9.3 Re-racking instructions

This section provides steps on how to re-rack the ActiveScale X100.

9.3.1 Re-racking order

Important: All components are installed from bottom to top.

Component	Rack unit location
1st PDU	0U (Vertical space in the rear of the rack)
2nd PDU	0U (Vertical space in the rear of the rack)
6th Storage Enclosure Basic	1U through 4U
5th Storage Enclosure Basic	5U through 8U
4th Storage Enclosure Basic	9U through 12U
3rd Storage Enclosure Basic	13U through 16U
2nd Storage Enclosure Basic	17U through 20U
1st Storage Enclosure Basic	21U through 24U
6th Storage Node	26U
5th Storage Node	27U
4th Storage Node	28U
3rd Storage Node	29U
2nd Storage Node	30U
1st Storage Node	31U
3rd System Node	32U
2nd System Node	33U
1st System Node	34U
2nd System Interconnect	35U
1st System Interconnect	36U
Management Interconnect	37U

9.3.2 Transferring the system hardware to the new rack

1. Shutdown the system.
 - a. Click **Resources**.
 - b. On multi-site systems, select a site from the **Sites** pull-down menu.
 - c. In the **Racks** pull-down menu, select a system.
 - d. In the rack's **Action** pull-down menu, select **Shutdown Rack**.

Figure 9-15. Resources > Rack > Shutdown

2. Remove the PDUs and re-install them in the new rack. For more information, refer to [PDU part replacement instructions](#) on page 43.
3. Remove the Storage Enclosure Basics and re-install them in the new rack. For more information, refer to [Storage Enclosure Basic part replacement instructions](#) on page 77.
4. Remove the Storage Nodes and re-install them in the new rack. For more information, refer to [Storage Node part replacement instructions](#) on page 69.
5. Remove the System Nodes and re-install them in the new rack. For more information, refer to [System Node part replacement instructions](#) on page 61.
6. Remove the System Interconnects and re-install them in new rack. For more information, refer to [System Interconnect part replacement instructions](#) on page 54.
7. Remove the Management Interconnect and install it in the new rack. For more information, refer to [Replacing Management Interconnects \(racked system\)](#) on page 51.

9.3.3 Completing re-racking

After system components have been moved to the new rack, perform the following adjustments:

- Original rack—Move the remaining components down in the rack. This will help accommodate maximum cable lengths and improve airflow through the components. Also, install blanking panels in open spaces between components to improve airflow and cooling.
- New rack—Install blanking panels in the open spaces between components to improve airflow and cooling.

Caution: Failure to add blanking panels in the appropriate locations can cause overheating.

- Once the installation process is complete, check the software to verify that everything has been done correctly. In order to verify the systems functionality, the customer bring-up (CBW) wizard must be completed. To complete the CBW, see the *ActiveScale X100 Installation Guide*.

10 Split-racking a system

This section describes how to perform a partial transfer of an ActiveScale X100 system into an additional rack. This process is referred to as *split-racking*.

Important: Additional PDUs are required in split-rack configurations.

10.1 Warnings and cautions

Warning: Failure to follow the guidelines in this section can cause serious issues or additional system downtime.

Important: Quantum Corporation recommends completing this procedure under the guidance of Quantum Corporation customer support.

When re-racking a system:

- Install and cable components one at a time. Use the cable labels to ensure that the cabling is correct.

Important: When cabling, system components are NOT interchangeable. For example, do not cable the sixth Storage Node to the fourth Storage Enclosure basic.

- Install components in the order and location directed.
- Before powering the system back on, ensure that all components are:
 - Cabled correctly
 - Installed in the correct U-locations

10.2 Rack Requirements

Ensure that you new rack or racks can meet the following requirements:

Note: To order the same rack used for the base ActiveScale system, refer to [Replaceable parts](#) on page 229.

- **System depth**—Select a rack mounting solution that has a depth of 47.24 in (1200 mm).
- **System weight**—Select a rack that can maintain a static load of 2000 lbs (907.18 kg)
- **Rack rails**—Select a rack with rails that are either:
 - Set 798 mm from the front of the rack to the mounting surface.
 - Back far enough to allow space for the molding of the power cords of the Storage Enclosure Basics to go between or around the front vertical rails.
- **Cabling and cable management**—Select a cable management system that can route cables safely through your system. Use the following guidelines:
 - Cables are wired from the rear of the system. In the case of the storage enclosures, the cables connect in the front of the rack and are run through cabling channels in the rail kit to the rear of the rack.
 - All cables provided are varying lengths based on the design of the whole system. The length of each cable is based on the length needed to cleanly connect to the necessary component ports.
 - There is a maximum supported length of seven meters for the DAC cables used in the ActiveScale X100.
- **Grounding**—Ensure that the electrical components used to power the system can be grounded safely.
- **Component dimensions**—Select a rack that can meet the dimensions for each system component. For the full set of dimensions for each component, refer to [System specifications](#) on page 227.

10.3 PDU requirements

Each rack requires its own PDUs:

- For single-phase, the original set of four PDUs can be split in pairs across both racks. You can also use the 1EX0284 upgrade kit.
- For three-phase, each rack will need to two PDUs (1EX0282 upgrade kit) for redundancy.

If you are not using the PDUs that came with your ActiveScale X100 after split-racking the system, follow the PDU requirements in this section.

Table 10-11. System Power requirements

Parameter	Minimum configuration	Full configuration
Power Connector Type	All connectors on each component are C14. The system comes with C13 to C14 cables. If these cables are not compatible with the site's selected PDU and power equipment, the user must provide compatible cables.	
Number of Connectors	35	35
Nominal System Power Required (W)	2.90 kW	6.50 kW
Maximum System Power Required (W)	4.0 kW	7.60 kW

Table 10-12. Component power measurements

Component	Average active power	Maximum active power
Management Interconnect	9 W	9 W
System Interconnect	83 W	85 W
System Node	196 W	228 W
Storage Node	200 W	229 W
Storage Enclosure Basic	804 W	873 W

10.3.1 Load balancing

When selecting a PDU, consider how to balance the electrical load on the PDU to prevent damaging power equipment or the system itself.

The following table shows how to balance the electrical load of a fully configured ActiveScale X100 as evenly as possible across 3-phase power on an 208V circuit.

Important: The following is only an example. Consult the specifications for the PDU being used, as well as the maximum wattage for the ActiveScale X100 system for a specific application to determine the appropriate load balance.

Important: In a split-rack scenario, balance half the components across the three phases.

Table 10-13. Three-phase load balancing a fully configured system on a 208V circuit

Phase XY	Amps	Phase YZ	Amps	Phase ZX	Amps
Management Interconnect	0.05A	System Interconnect 1	0.409A	System Interconnect 2	0.409A
System Node 1	1.1A	System Node 2	1.1A	System Node 3	1.1A
Storage Node 2	1.1A	Storage Node 4	1.1A	Storage Node 6	1.1A
Storage Node 1	1.1A	Storage Node 3	1.1A	Storage Node 5	1.1A
Storage Enclosure Basic 2	4.2A	Storage Enclosure Basic 4	4.2A	Storage Enclosure Basic 6	4.2A
Storage Enclosure Basic 1	4.2A	Storage Enclosure Basic 3	4.2A	Storage Enclosure Basic 5	4.2A
Phase XY Total	12.1A	Phase YZ Total	12.1A	Phase ZX Total	11.7A
Total Apparent Power			7.6 kVA		

10.4 Split-racking instructions

The original rack will remain part of the process of splitting the racks into two footprints. To minimize the effort of this process, by design, the original rack will have half of the enclosures and three servers removed and installed into the new rack.

Figure 10-16. Split rack configuration

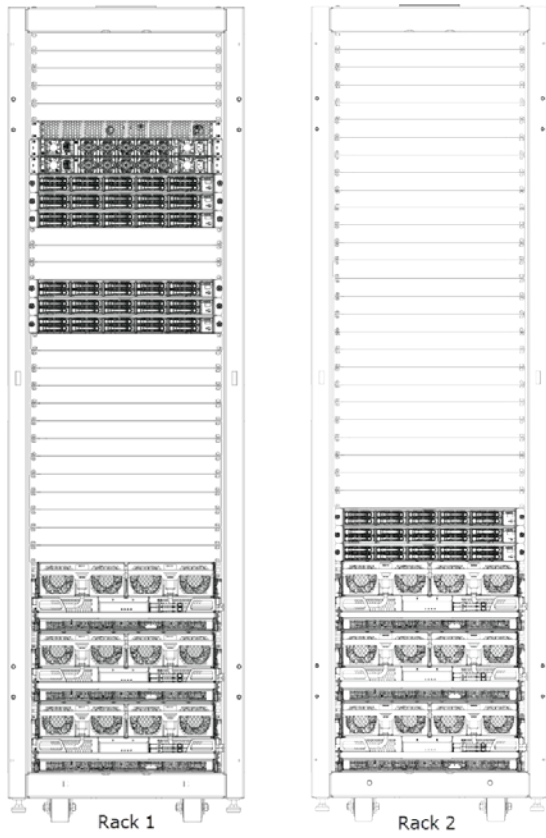

10.4.1 Split racking order

Rack two component	Rack unit location
6th Storage Enclosure Basic	1U through 4U
5th Storage Enclosure Basic	5U through 8U
4th Storage Enclosure Basic	9U through 12U
6th Storage Node	13U
5th Storage Node	14U
4th Storage Node	15U

10.4.2 Moving the system hardware to the second rack

1. Shutdown the system.
 - a. Click **Resources**.
 - b. On multi-site systems, select a site from the **Sites** pull-down menu.
 - c. In the **Racks** pull-down menu, select a system.
 - d. In the rack's **Action** pull-down menu, select **Shutdown Rack**.

Figure 10-17. Resources > Rack > Shutdown



2. Remove the Storage Enclosure Basics and re-install them in the new rack. For more information, refer to [Replacing Storage Enclosure Basic chassis](#) on page 71.

Note: Remove the top Storage Enclosure Basic (#6) and immediately assemble it in the other rack. This will result in the original rack having (from bottom to top)

Storage Enclosure Basics numbered 1, 2, and 3, and the other rack having Storage Enclosure Basics (from bottom to top) numbered 6, 5, and 4.

3. Remove the Storage Nodes and re-install them in the new rack. For more information, refer to [Replacing Storage Nodes](#) on page 47.

10.4.3 Completing split-racking

After the system components have been moved to the new rack, Quantum Corporation recommends that you perform the following adjustments:

- **Original rack**—move the remaining components down in the rack. This will help accommodate maximum cable lengths and improve airflow through the components. Also, install blanking panels in open spaces between components to improve airflow and cooling.
- **New rack**—install blanking panels in open spaces between components to improve airflow and cooling.

Caution: Failure to add blanking panels in the appropriate locations can cause serious issues with overheating.

Once the installation process is complete, check the software to verify that everything has been done correctly. In order to verify the systems functionality, the configuration wizard must be completed. To complete the configuration wizard, see the *ActiveScale X100 Installation Guide*.

10.4.4 Cabling for split-rack single-phase PDU configurations

Re-cable the system using the [Cabling map](#) on page 119 and the labels on each cable.

11 Troubleshooting the ActiveScale™ X100

This section provides all of the collected troubleshooting steps required to diagnose problems with the ActiveScale X100. This section will be updated from time to time with new troubleshooting steps as more methods and solutions become available.

11.1 Troubleshooting Storage Enclosure Basic

This section provides instruction on how to troubleshoot the Storage Enclosure Basic and the major components contained within the enclosure. Because the ActiveScale X100 contains six Storage Enclosure Basic, any one enclosure may be taken offline at any give point for troubleshooting various parts that are not hot swappable. However, before a Storage Enclosure Basic is taken off line, its corresponding Storage Node must be taken offline first. The enclosure contains hot swappable power supply units and fan modules that may go through troubleshooting methods while the enclosure is still running.

11.1.1 Troubleshooting a fan fault LED

To troubleshoot a fan fault LED on the Storage Enclosure Basic, do the following:

1. From the rear of the rack, identify the Storage Enclosure Basic fan that is indicating a fault. The fan LED will be flashing amber at a rate of one second intervals.

Figure 11-18. Fan LED

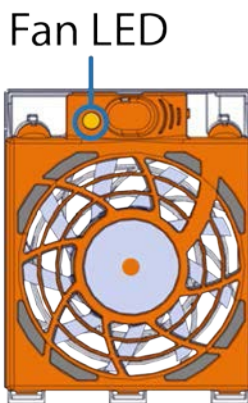

2. Remove and replace the fan.

Important: Ensure that the rear fans are replaced quickly. The rear fan removes hot air from the enclosure. If the enclosure contains a failed fan for prolonged periods of time, the risk of overheating will be elevated.

Warning: Do not place fingers anywhere near the fan blades while powered on.

3. Verify that the fault LED is no longer on.
4. If the fault LED is still on, do the following:
 - a. Swap the fan that is indicating a fault with another fan on the enclosure.
 - b. If the fault LED is still lit, the fan may need to be replaced.
 - c. If the slot that had the failed fan fault still has the LED lit after installing a fan that is known to be working, then the corresponding sled may need to be replaced.

11.1.2 Troubleshooting an HD MiniSAS cable LED fault

1. From the front of the rack, identify the Storage Enclosure Basic with the HD MiniSAS cable that is indicating a fault on the I/O module.
2. From the identified Storage Enclosure Basic, remove and replace the HD MiniSAS cable by pulling the blue release tab and pulling the plug out of the **I/O module**.
3. Verify that the LED is green indicating that the connection is working properly.
4. If the fault LED is still on, do the following:
 - a. Swap the HD MiniSAS cable that is indicating a fault with another HD MiniSAS cable on the enclosure.
 - b. If the fault LED is still lit, the HD MiniSAS cable may need to be replaced.

11.1.3 Troubleshooting a power supply unit fault LED

To perform the self-diagnostic for power supply units (PSUs), swap the PSUs and observe if the fault follows the PSU.

Note: One PSU can be removed without taking the enclosure down. One PSU from one enclosure can be swapped with one PSU from a different enclosure to check if the problem follows the PSU. However, if you need to remove both PSUs, you will need to first use ActiveScale SM to quiesce I/O on the Storage Node that is managing the Storage Enclosure Basic you are working on.

If it does not, perform the following procedure:

1. From the front of the rack, identify the Storage Enclosure Basic power supply unit that is indicating a fault.
2. From the identified Storage Enclosure Basic, remove and replace the power supply unit indicating a fault. Verify that the fault LED is no longer on.
3. If the fault LED is still on, do the following:
 - a. Swap the power supply unit that is indicating a fault with the other power supply unit on the enclosure.
 - b. If the fault LED is still lit, the power supply unit may need to be replaced.

11.1.4 Troubleshooting an I/O module fault LED

1. From the front of the rack, identify the Storage Enclosure Basic I/O module that is indicating a fault.
2. Log into ActiveScale SM using the proper administration username and password.
3. In ActiveScale SM, from the left-hand pane, select **Resources**.

Figure 11-19. Resources

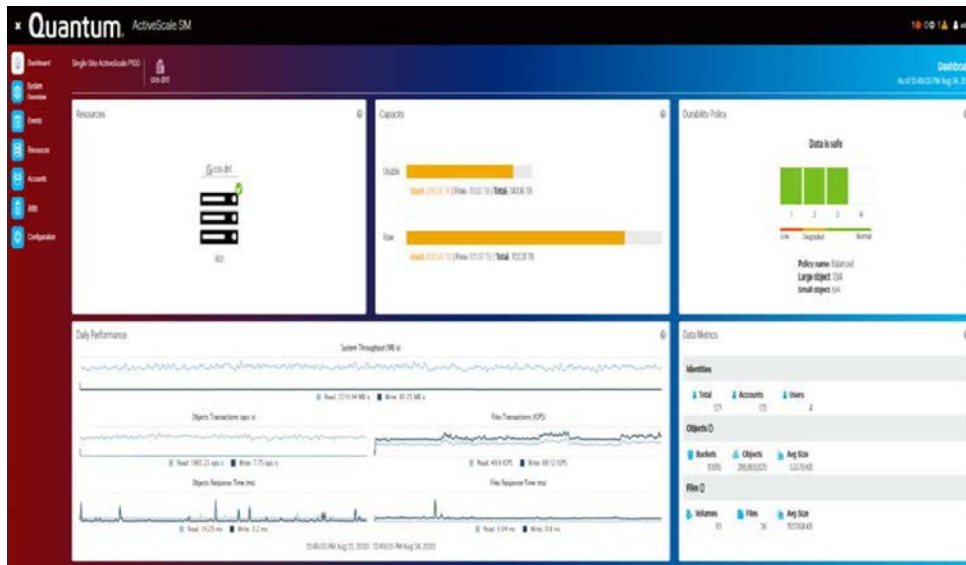

4. Under **System Health**, locate the Storage Enclosure Basic you want to work on.
 5. From system display, select the **Storage Node** that is linked to the Storage Enclosure Basic.
- The **Resources** section appears and displays the layout of the Storage Node that Basic was selected.

Note: For example, the top Storage Node is linked to the top Storage Enclosure, and so on.

Figure 11-20. Resources > Storage Node

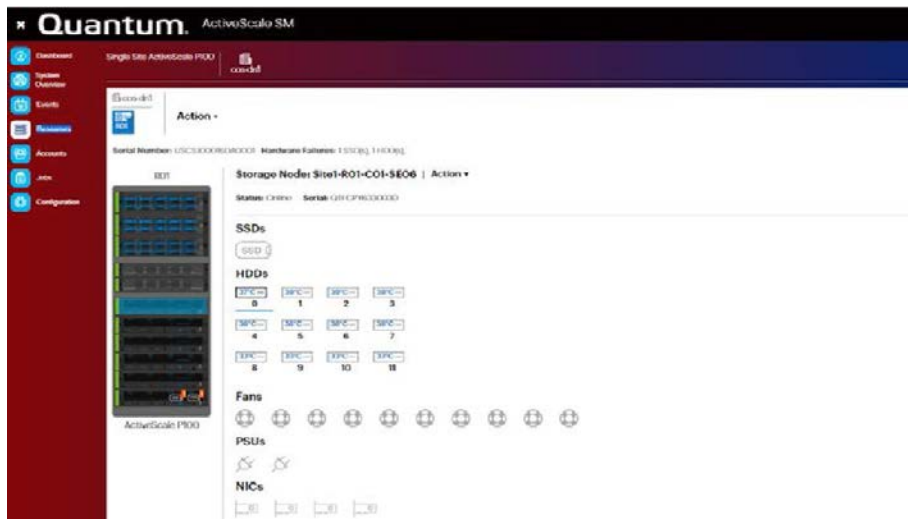

- Next to the Storage Node title, select **Action** > **Shutdown**. The Machine Shutdown dialogue box appears.

Figure 11-21. Action



- Type the password for admin.
- Click **Shut Down**.

The Storage Node is shut down.

- After the Storage Node that manages the Storage Enclosure Basic has been quiesced, remove the I/O module indicating a fault by unplugging the power cables by lifting the **power cord retention bale** and carefully removing the power cord from the **power supply**.

Note: Repeat for both the A and B power supplies.

Figure 11-22. Removing the power cords



Note: Power cords marked in red. Cord retention bale marked in blue.

- Unplug the HD MiniSAS cables by pulling the blue release tab and pulling the plug out of the **I/O module**.

Figure 11-23. Removing the HD MiniSAS cables

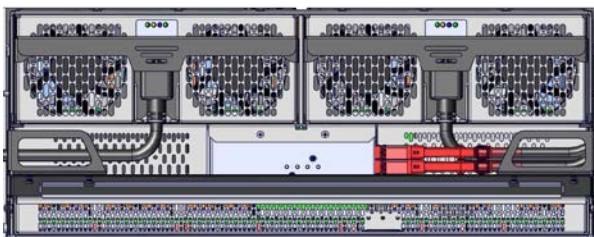

Note: The HD MiniSAS cables are marked in red. Take note of which HD MiniSAS cable can from which port to ensure that they are plugged in correctly when reassembling.

11. With your palms facing up, place the **pointer** and **middle** finger into the **latch handle sides**.

Figure 11-24. Latch handle identification



Note: Latch handle is marked in red. Rack ears are marked in yellow.

12. With your **thumbs** on the **rack ears**, pull the **latch handle sides** and push on the **rack ear release**.
13. Pull the **latch handle** until clear of the **rack ear latch**.

Figure 11-25. Latch handle clear of rack ear

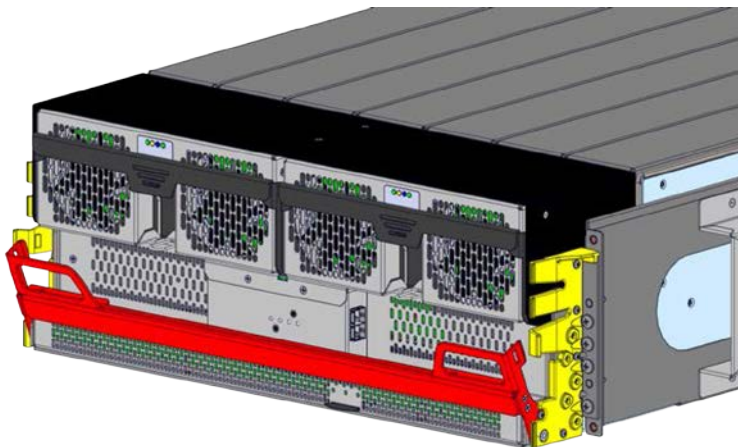

Note: Latch handle is marked in red. Rack ears are marked in yellow.

14. With your palms facing up, reposition your hands so that your thumbs are on the outside and your fingers cradle the bottom and rear of either side of the I/O module.
15. Slowly pull the **I/O module** away from the **chassis**.

Warning: The I/O module is very top-heavy. Ensure that you are fully supporting the component during the removal.

Figure 11-26. Removing the I/O module

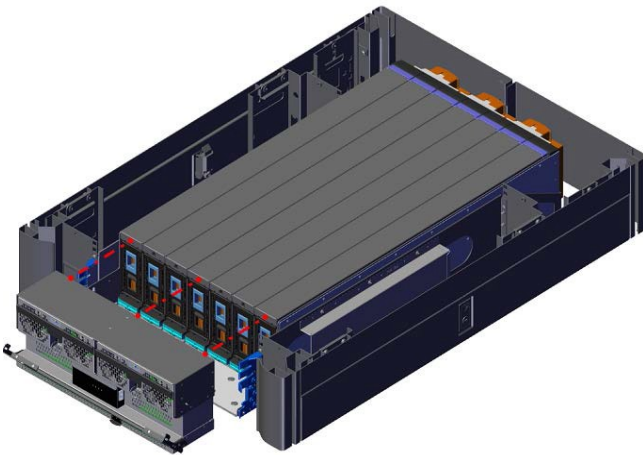

16. Install the replacement I/O module in the reverse order that you removed it.
17. Reconnect the enclosure power cords and network cables.
18. Verify that the fault LED is no longer on.
19. If the fault LED is still on, do the following:
 - a. Swap the I/O module that is indicating a fault with another enclosure I/O module.
 - b. If the fault LED is still lit, the I/O module may need to be replaced.
20. If the fault LED is off, restart the Storage Node and verify that the Storage Enclosure Basic is functioning properly.

11.1.5 Troubleshooting a sled fault LED

To perform the self-diagnostic for a sled, swap the sled that is displaying a fault condition into a different enclosure, and observe if the fault follows the sled.

If it does not, perform the following procedure:

Figure 11-27. Front and rear view of sled



Warning: To prevent damage to sled components and connectors:
Do not put any weight on either end of the sleds.
Do not stand sleds on either end.

1. Identify the Storage Enclosure Basic that is indicating the fault.
2. Log into ActiveScale SM using the proper administration username and password.

Figure 11-28. ActiveScale SM



- In ActiveScale SM, from the left-hand pane, select **Resources**.

Figure 11-29. Resources

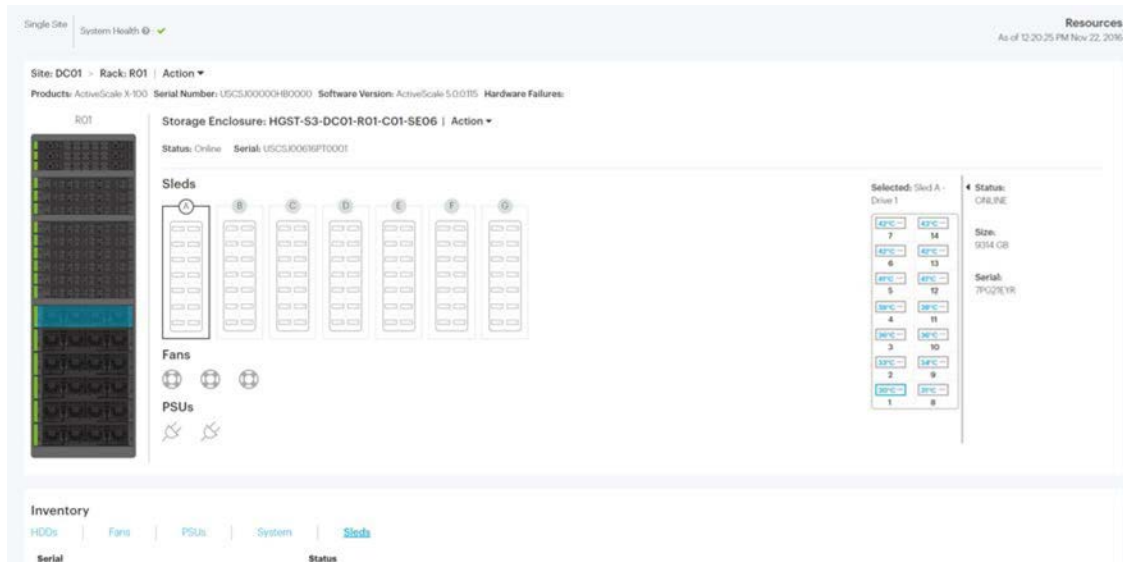

- Under **System Health**, locate the Storage Enclosure you want to work on.
 - From system display, select the **Storage Node** that is linked to the Storage Enclosure.
- The Resources section appears and displays the layout of the Storage Node that was selected. For example, the top Storage Node is linked to the top Storage Enclosure, and so on.

Figure 11-30. Resources > Storage Node

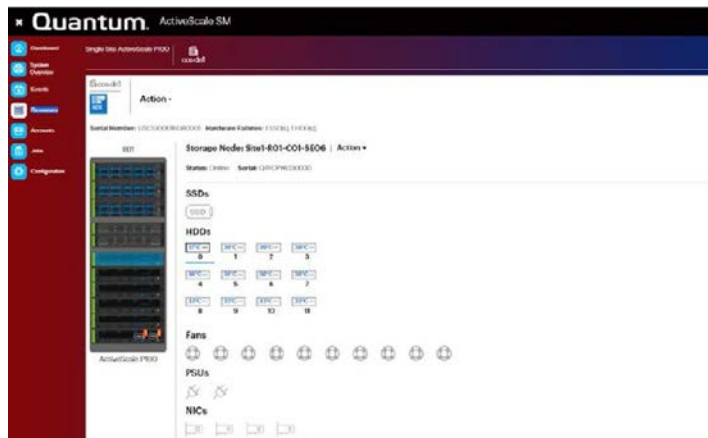

- Next to the Storage Node title, select **Action > Shutdown**. The Machine Shutdown dialogue box appears.

Figure 11-31. Action > Shutdown



- Type the password for admin.
- Click **Shut Down**.

The Storage Node is shut down.

- Remove the I/O module from the Storage Enclosure Basic.
 - Starting with the Storage Enclosure Basic that has the problem, unplug the power cords.
 - On the same Storage Enclosure Basic, unplug the HD miniSAS cables by pulling the blue tab and removing the cable from the port.
 - Unlock the I/O module from the enclosure by pulling the latch handle out and away from the I/O module.

Figure 11-32. Unlocking the I/O module

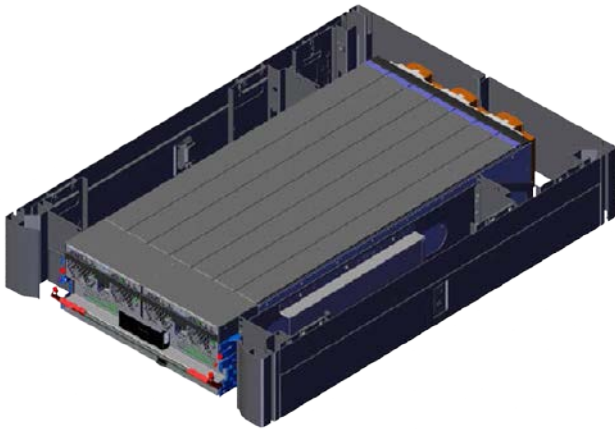

- d. Slide the I/O module away from the chassis.

Figure 11-33. Removing the I/O module

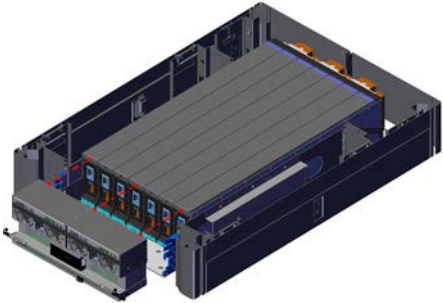

10. From the identified Storage Enclosure Basic, remove the sled indicating a fault by pressing the **latch mechanism button** on the front of the sled until it is at a 45° angle and pull the sled out of the enclosure.

Figure 11-34. Removing the sled

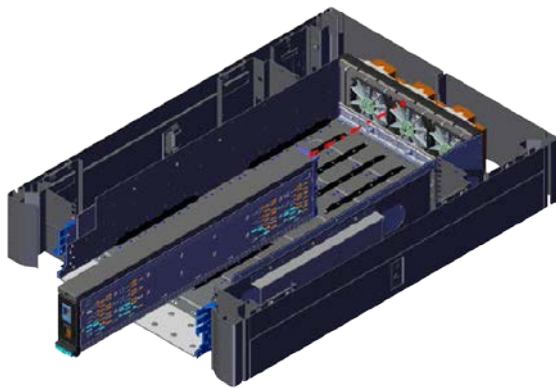

11. Reinstall the sled displaying the fault in the reverse order that you removed it.

Figure 11-35. Reinstalling the sled

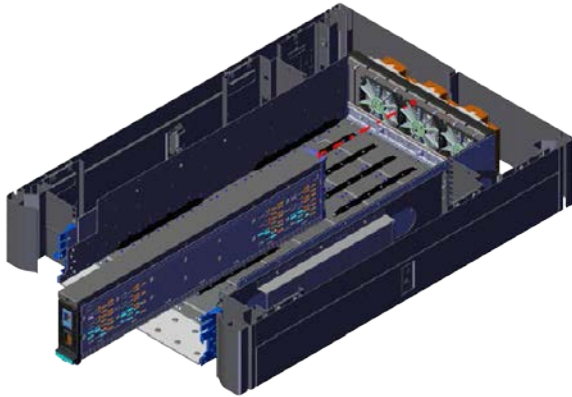

12. Install the I/O module into the Storage Enclosure Basic.
 - a. Set the I/O module half-way into the Storage Enclosure Basic chassis with the handle still unlocked.

Figure 11-36. Sliding the I/O module into the chassis

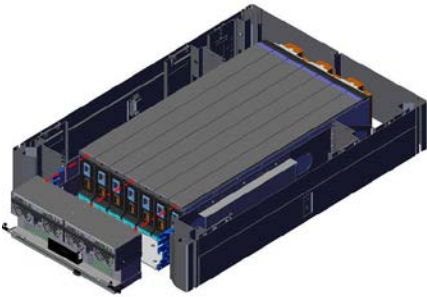

- b. Plug in the HD miniSAS cables into the HD miniSAS ports.
- c. Plug in the power cords into the power cord ports at the bottom of each power supply unit.
- d. Push the I/O module into the chassis until seated against the sleds.
- e. Lock the I/O module handle by pushing the latch handle into the I/O module.

Figure 11-37. Locking the I/O module

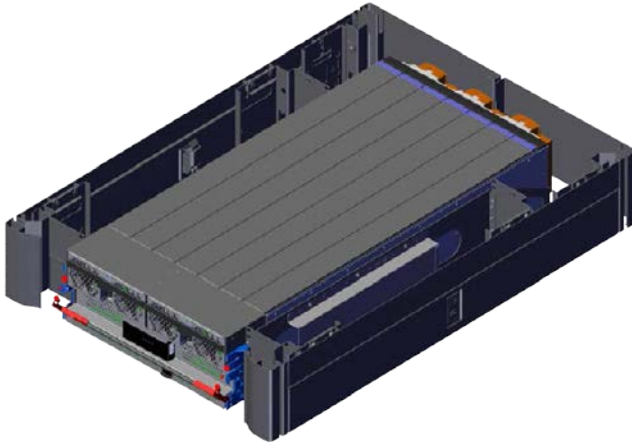

13. Reconnect the enclosure power cords and network cables.
14. Verify that the fault LED is no longer on.
15. If the fault LED is still on, do the following:
 - a. Swap the sled that is indicating a fault with another enclosure sled.
 - b. If the fault LED is still lit, the sled may need to be replaced.
16. If the fault LED is not on, restart the Storage Node and verify that the Storage Enclosure Basic is functioning properly.

11.1.6 Troubleshooting a drive fault LED

To troubleshoot the drive fault LED, do the following:

1. Identify the Storage Enclosure Basic that is indicating the fault.
2. Log into ActiveScale SM using the proper administration username and password.
3. In ActiveScale SM, from the left-hand pane, select **Resources**.

Figure 11-38. Resources

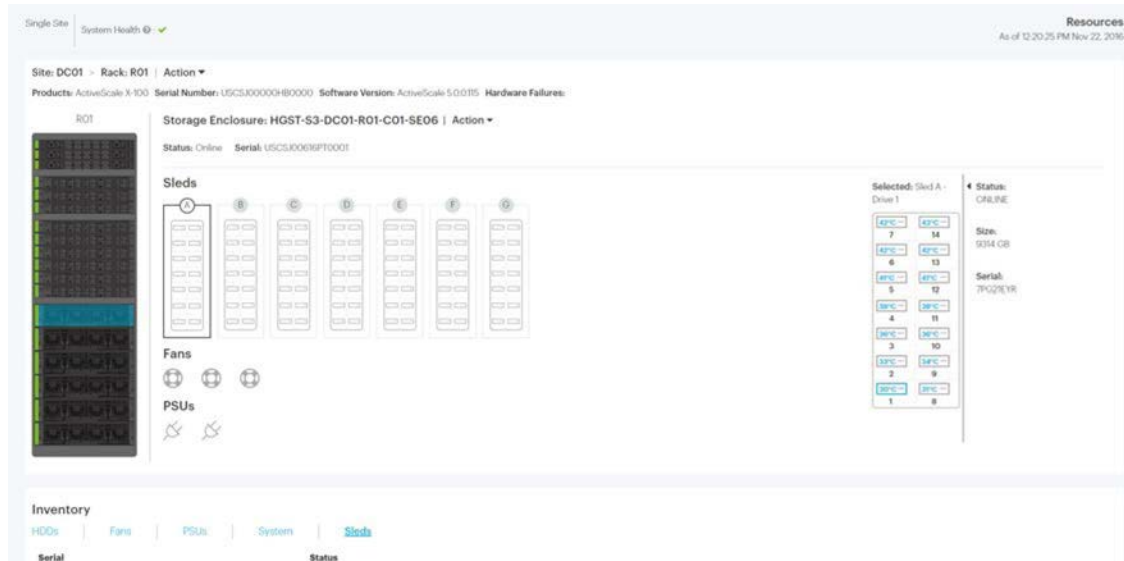

4. Under **System Health**, locate the Storage Enclosure you want to work on.
 5. From system display, select the **Storage Node** that is linked to the Storage Enclosure.
- The Resources section appears and displays the layout of the Storage Node that was selected. For example, the top Storage Node is linked to the top Storage Enclosure, and so on.

Figure 11-39. Resources > Storage Node

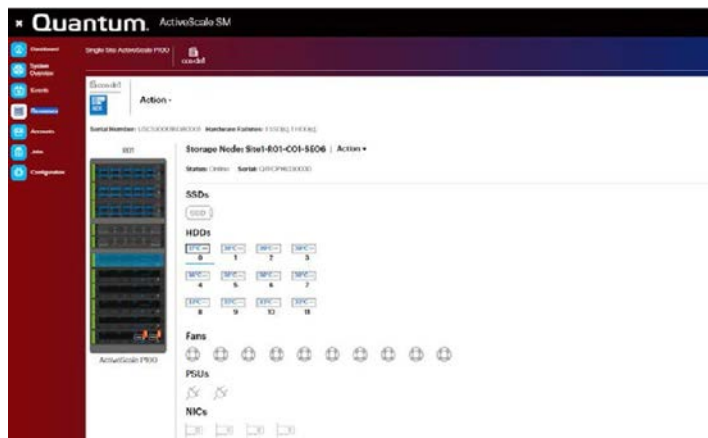

- Next to the Storage Node title, select **Action** > **Shutdown**. The Machine Shutdown dialogue box appears.

Figure 11-40. Action



- Type the password for admin.
- Click **Shut Down**.

The Storage Node is shut down.

- Unplug the power cables on the I/O module by lifting the **power cord retention bale** on each of the PSUs and carefully removing the power cords.

Figure 11-41. Removing the power cords

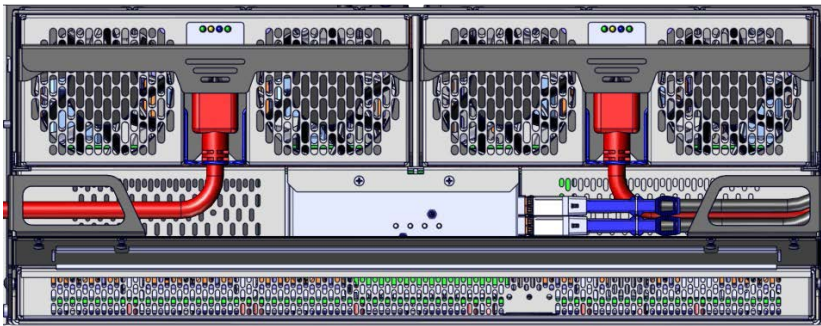

Note: Power cords are marked in red. Cord retention bale is marked in yellow.

- Unplug the HD Mini-SAS cables from the **I/O module**.

Figure 11-42. Removing the HD Mini-SAS cables



Note: The HD Mini-SAS cables are marked in red. Take note of which HD Mini-SAS cable came from which port to ensure that they are plugged in correctly when reassembling.

11. Unlock the I/O module from the enclosure by pulling the **latch handle** out and away from the I/O module.

Figure 11-43. Unlocking the I/O module

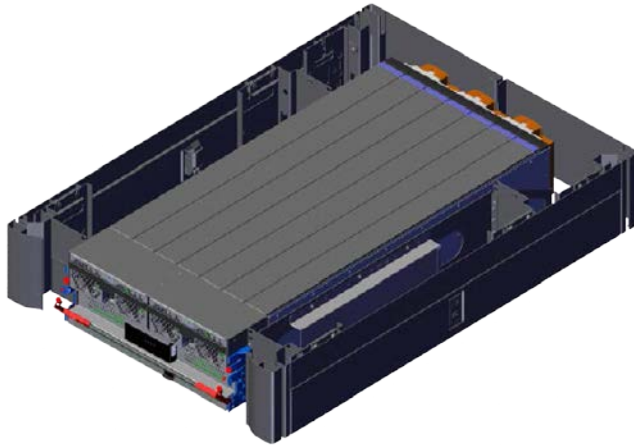

12. Slide the **I/O module** away from the **chassis**.

Figure 11-44. Removing the I/O module

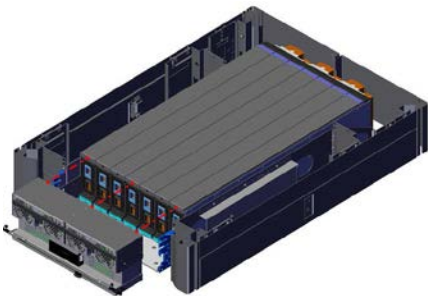

13. Locate the sled that contains the flashing **Ident** LED.

Note: This sled contains the hard disk drive that the storage administrator has identified.

14. On the front of the sled, press the **latch mechanism button** and pull it until it is at a 45 degree angle.

Figure 11-45. Sled release button

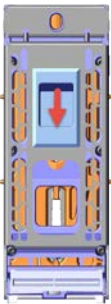
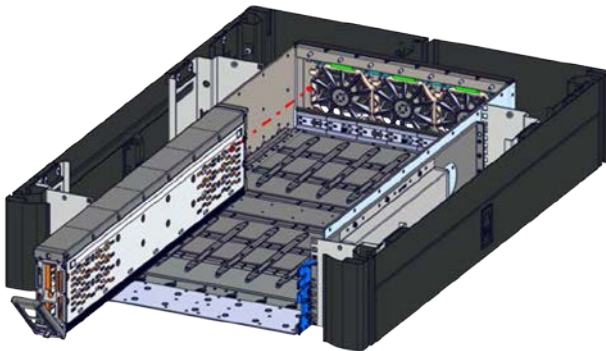
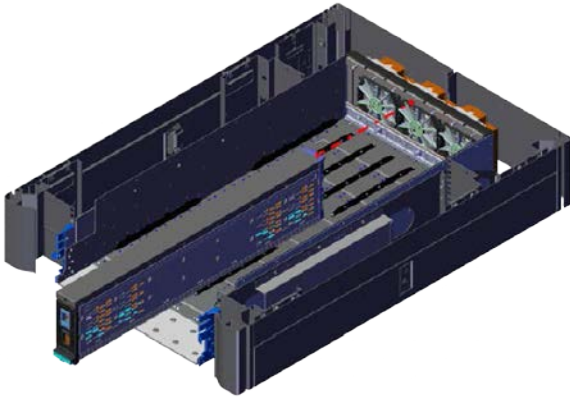

Figure 11-46. Sled release at 45 degrees



15. Remove the sled displaying hard disk drive LED fault from the chassis.

Figure 11-47. Removing the sled



16. On the sled, push the drive cover back and up until the cover has been removed.

Figure 11-48. Sled cover

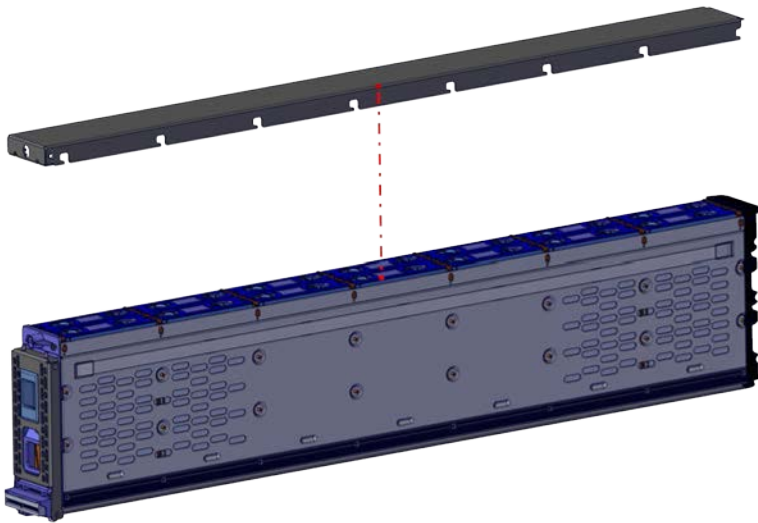

17. From the sled, locate the flashing hard disk drive fault LED.

Figure 11-49. Hard disk drive fault LED



18. To remove the hard disk drive, on the hard drive carrier, press the two buttons and remove the drive.

Figure 11-50. Hard disk drive buttons

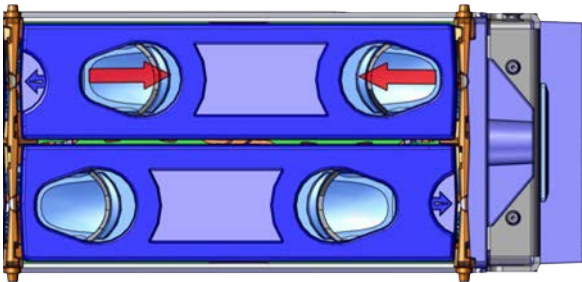
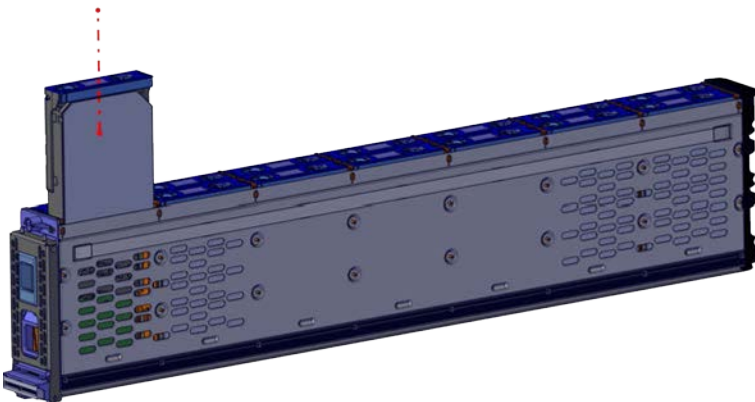

Figure 11-51. Removing the hard disk drive



19. Reinstall the hard disk drive in the reverse order that it was removed.

Note: While installing the replacement hard disk drive, face the drive carrier towards the inside of the sled.

Note: Ensure that you press the drive carrier buttons completely while loading the hard disk drive.
If the supercap discharges and can no longer power the LEDs, the LED state will be saved in non-volatile memory so that when the enclosure is booted, the

administrator will still be able to identify the enclosure and component in question.

20. Install the remaining enclosure components in the reverse order that you removed them.
21. Reconnect the enclosure power cords and network cables
22. Verify that the fault LED is no longer on.
23. If the fault LED is still on, the drive may need to be replaced.
24. If the fault LED is not on, restart the Storage Node and verify that the Storage Enclosure Basic is functioning properly.

11.2 Troubleshooting power distribution units

This section provides instruction on how to troubleshoot the power distributions units (PDU). Because the ActiveScale X100 contains four single-phase PDUs and two 3-phase PDUs, one PDU may be taken offline at any give point for troubleshooting.

11.2.1 Troubleshooting tripped breakers on a PDU

To troubleshoot tripped breakers on a PDU, do the following:

1. From the rear of the rack, identify the PDU that displays an error of **bE** on the readout located near the middle of the mounted PDU.
2. On the PDU, inspect the breakers located above each of the phases.
3. If one of the phases has a switch that has rotated out and displaying a red portion, this is the breaker that has been tripped.

Note: All functioning breaker switches will be flush with the breaker.

4. Press the tripped breaker switch until it is no longer sticking out.
5. Verify that the PDU LED no longer displays an error on the PDU readout.

12 System specifications

This section provides the specifications for the ActiveScale X100.

12.1 System specification summary

The following table is a summary of specifications relevant to the ActiveScale X100.

Condition (fully configured)	Non-operating	Operating
Altitude	-984 ft to 39,371 ft (-300 m to 12,000 m)	-984 ft to 10,000 ft (-300 m to 3048 m)
Packed system dimensions	<ul style="list-style-type: none"> • Width—41.4 in (1052 mm) • Depth—61.41 in (1560 mm) • Height—88.3 in (2243 mm) 	
Power requirements	N/A	<p>Base configuration typical/max:</p> <ul style="list-style-type: none"> • 2.5/3.3 kW <p>Base +1 configuration typical/max:</p> <ul style="list-style-type: none"> • 3.15/3.98 kW <p>Base +2 configuration typical/max:</p> <ul style="list-style-type: none"> • 3.8/4.66 kW <p>Base +3 configuration typical/max:</p> <ul style="list-style-type: none"> • 4.45/5.34 kW <p>Base +4 configuration typical/max:</p> <ul style="list-style-type: none"> • 5.1/6.02 kW <p>Base +5 configuration typical/max:</p> <ul style="list-style-type: none"> • 5.75/6.7 kW <p>Full (Base +6) configuration typical/max:</p> <ul style="list-style-type: none"> • 6.4/7.4 kW <p>System Expansion Node kit:¹</p> <ul style="list-style-type: none"> • .195 to 0.23 kW
Rack units (U)	42U ²	
Relative humidity	10% to 95% non-condensing	8% to 90% non-condensing
System dimensions	<ul style="list-style-type: none"> • Width—23.6 in (600 mm) • Depth—52.6 in (1338 mm) • Height—81.1 in (2060 mm) 	
System dimensions (without doors)	<ul style="list-style-type: none"> • Width—23.6 in (600 mm) • Depth—47.2 in (1200 mm) • Height—81.1 in (2060 mm) 	
Temperature	40°F to 158°F (-40°C to 70°C)	50°F to 95°F (10°C to 35°C)
Temperature de-rating	33.8°F per 984.2 ft above 9842.5 ft (1°C per 300 m above 3000 m)	33.8°F per 984.2 ft above 3116.8 ft (1°C per 300 m above 950 m)
Temperature gradient	86°F (30°C)/hour	68°F (20°C)/hour

Condition (fully configured)	Non-operating	Operating
Thermal output	N/A	<p>Base configuration (one column of populated sleds):</p> <ul style="list-style-type: none"> • 8.53/11.26 KBTU/h <p>Base +1 configuration (two column of populated sleds):</p> <ul style="list-style-type: none"> • 10.75/13.59 KBTU/h <p>Base +2 configuration (three column of populated sleds):</p> <ul style="list-style-type: none"> • 12.96/15.92 KBTU/h <p>Base +3 configuration (four column of populated sleds):</p> <ul style="list-style-type: none"> • 15.17/18.25 KBTU/h <p>Base +4 configuration (five column of populated sleds):</p> <ul style="list-style-type: none"> • 17.38/20.58 KBTU/h <p>Base +5 configuration (six column of populated sleds):</p> <ul style="list-style-type: none"> • 19.59/22.91 KBTU/h <p>Full configuration (base +6, seven columns of populated sleds):</p> <ul style="list-style-type: none"> • 21.83/ 25.25 KBTU/h <p>System Expansion Node kit:¹</p> <ul style="list-style-type: none"> • 0.665 to 0.785 KBTU/hour
Weight	<ul style="list-style-type: none"> • Minimum system weight³—1572 lbs (713 kg) • Full system weight—2227 lbs (1010 kg) • Delivery weight (system and packaging)—2457 lbs (1114 kg) 	

1. Values are for one additional node. System Expansion Node kits can contain up to three additional nodes.

2. Rackless system height can vary based on the installation. A rackless configuration uses 36U of equipment.

3. The minimum system weight does not include the rack and PDUs

12.2 Hard disk drive specifications

The following tables list the specifications for the Quantum Corporation qualified hard disk drives contained within the System Nodes, Storage Nodes, and Storage Enclosure Basics

Table 12-14. 1 TB hard disk drive specification summary

Condition	Specification
Model	Quantum Corporation Travelstar® 7K1000
Capacity	1 TB
Dimensions	<ul style="list-style-type: none"> • Width—2.75 in (70 mm) • Depth—3.93 in (100 mm) • Height—.37 in (9.5 mm)
Hot swappable?	Yes ¹

Table 12-14. 1 TB hard disk drive specification summary

Condition	Specification
Operating relative humidity	5% to 95%, non-condensing
Operating temperature	0°C to 70°C (32°F to 158°F) internal
Quantity (per system)	<ul style="list-style-type: none"> • Four per System Node • Four per Storage Node
Replacement part number	1EX0222
Type	SATA

1. Only hot swappable after decommissioning.

Table 12-15. 10 TB hard disk drive specification summary

Condition	Specification
Model	Quantum Corporation Ultrastar® He10
Capacity	10 TB
Dimensions	<ul style="list-style-type: none"> • Width—4 +/-0.0098 in (101.6 +/-0.25 mm) • Depth—5.78 (147 mm) • Height—1.02 in (26.1 mm)
Hot swappable?	No
Operating relative humidity	5% to 95%, non-condensing
Operating temperature	0°C to 70° C (32°F to 158°F) internal
Quantity	<ul style="list-style-type: none"> • 14 per sled • 98 per Storage Enclosure Basic
Replacement part number	1EX0170
Type	SAS

Table 12-16. 12 TB hard disk drive specification summary

Condition	Specification
Model	Quantum Corporation Ultrastar® He12
Capacity	12 TB
Dimensions	<ul style="list-style-type: none"> • Width—4 +/-0.0098 in (101.6 +/-0.25) mm • Depth—5.78 (147 mm) • Height—1.02 in (26.1 mm)
Hot swappable?	No
Operating relative humidity	5% to 95%, non-condensing
Operating temperature	0°C to 70° C (32°F to 158°F) internal
Quantity	<ul style="list-style-type: none"> • 14 per sled • 98 per Storage Enclosure Basic
Replacement part number	1EX0411
Type	SAS

Table 12-17. 14 TB hard disk drive specification summary

Condition	Specification
Model	Quantum Corporation Ultrastar® HD HC500
Capacity	14 TB
Dimensions	<ul style="list-style-type: none">• Width—4 +/-0.0098 in (101.6 +/-0.25) mm• Depth—5.78 (147 mm)• Height—1.02 in (26.1 mm)
Hot swappable?	No
Operating relative humidity	5% to 95%, non-condensing
Operating temperature	0°C to 70° C (32°F to 158°F) internal
Quantity	<ul style="list-style-type: none">• 14 per sled• 98 per Storage Enclosure Basic
Replacement part number	1EX1121
Type	SAS

12.3 Management Interconnect specifications

The following table lists the system specifications for an individual Management Interconnect.

Table 12-18. Management Interconnect Specifications

Condition	Specification
Dimensions	<ul style="list-style-type: none"> • Width—8.23 in (209 mm) • Depth—9.84 in (250 mm) • Height—1.62 in (41.25 mm)
Hot swappable?	No
Operating relative humidity	10% to 90% non-condensing
Operating temperature	32°F to 122°F (0°C to 50°C)
Quantity (per system)	1
Rack units (U)	1U
Weight	4.14 lbs (1.88 kg)

12.4 PDU specifications

Table 12-19. Three-phase PDU specification summary

Condition	Three-phase (Delta) L15-30P	Three-phase (Delta) L21-30P	Three-phase (Wye) IEC 60309 16A 4P+E	Three-phase (Wye) IEC 60309 32A 4P+E
Model	STV-4502E	STV-4502M	STV-4503J	STV-6503K
Part number	1EX0249	1EX0262	1EX0250	1EX0263
Hot swappable?	Yes	Yes	Yes	Yes
Quantity (per system)	2	2	2	2
Plug standard	NEMA L15-30P	NEMA L21-30P	IEC 60309 16A 4P+E	IEC 60309 32A 4P+E
Outlet standard	NEMA L15-30R	NEMA L21-30R	IEC 60309 16A 4P+E	IEC 60309 32A 4P+E
Weight	19 lbs (8.6 kg)	20 lbs (9 kg)	21 lbs (9.5 kg)	20 lbs (9 kg)
Dimensions	<ul style="list-style-type: none"> • Width—2.2 in (56 mm) • Depth—2.25 in (58 mm) • Height—69 in (1753 mm) 	<ul style="list-style-type: none"> • Width—2.2 in (56 mm) • Depth—2.25 in (58 mm) • Height—69 in (1753 mm) 	<ul style="list-style-type: none"> • Width—2.2 in (56 mm) • Depth—2.25 in (58 mm) • Height—70 in (1778 mm) 	<ul style="list-style-type: none"> • Width—2.2 in (56 mm) • Depth—2.25 in (58 mm) • Height—70 in (1778 mm)
Rack position	Rear of the rack 0U	Rear of the rack 0U	Rear of the rack 0U	Rear of the rack 0U
Operating temperature	32°F to 140°F (0°C to 60°C)	32°F to 140°F (0°C to 60°C)	32°F to 140°F (0°C to 60°C)	32°F to 140°F (0°C to 60°C)

Table 12-20. Single-phase PDU specification summary

Condition	Single-phase NEMA L6-30P	Single-phase IEC 60309 24A 2P+E
Model	STV-4501C	STV-6501K
Part number	1EX0251	1EX0264
Hot-swappable	Yes	Yes
Condition	Single-phase NEMA L6-30P	Single-phase IEC 60309 24A 2P+E

Condition	Single-phase NEMA L6-30P	Single-phase IEC 60309 24A 2P+E
Quantity (per system)	4	4
Plug standard	NEMA L6-30P	IEC 60309 32A 2P+E
Outlet standard	NEMA L6-30R	IEC 60309 32A 2P+E
Weight	18 lbs (8.1 kg)	18 lbs (8.1 kg)
Dimensions	<ul style="list-style-type: none"> • Width—2.2 in (56 mm) • Depth—2.3 in (56 mm) • Height—69 in (1753 mm) 	<ul style="list-style-type: none"> • Width—2.2 in (56 mm) • Depth—2.25 in (58 mm) • Height—69 in (1753 mm)
Rack position	Rear of the rack 0U	Rear of the rack 0U
Operating temperature	32°F to 140°F (0°C to 60°C)	32°F to 140°F (0°C to 60°C)

12.4.1 Power cords

Use only tested and approved power cords that are connected to either:

- Properly grounded power outlets.
- The insulated sockets of the rack internal power supply.

If an AC power cord was not provided with your product, purchase one that is approved for use in your country.

To avoid electrical shock or fire, check the power cords that will be used with the product as follows:

- The power cord must have an electrical rating that is greater than that of the electrical current rating marked on the product.
- Do not attempt to modify or use the AC power cord(s) if they are not the exact type required to fit into the grounded electrical outlets.
- The power supply cord(s) must be plugged into socket-outlet(s) that is /are provided with a suitable earth ground.
- The power supply cord(s) is / are the main disconnect device to AC power. The socket outlet(s) must be near the equipment and readily accessible for disconnection.

12.5 Rack specifications

The following table lists the rack specifications for the racked ActiveScale X100. Rackless versions of the ActiveScale X100 use customer-supplied racks.

Figure 12-52. Rack dimensions

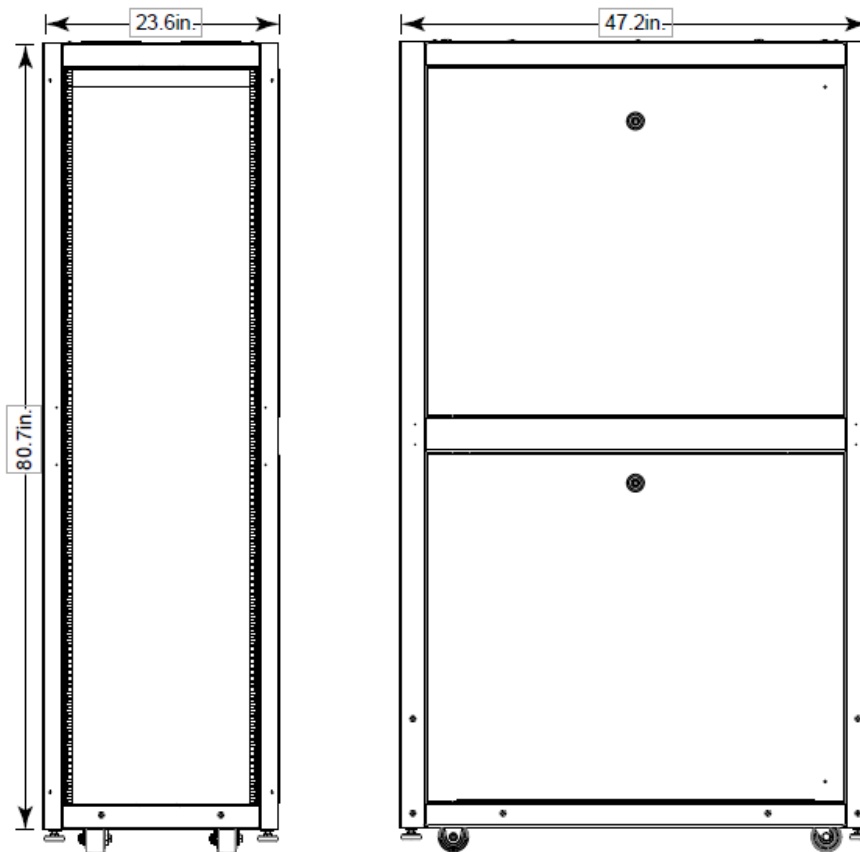

Table 12-21. Rack specifications

Condition	Specification
Bracing	Basic bracing, using the L-brackets, is standard with the shipping materials and used to brace the system to the data center floor.
Doors	Standard, single leaf, top and bottom vented, front and rear doors are shipped with the system
Power cord route management	The system's power cord can be routed through the top or the bottom. The standard route for the system's power cord is through the top of the rack.
Rack units	42U
System dimensions	<ul style="list-style-type: none"> • Width—23.6 in (600 mm) • Depth—52.6 in (1338 mm) • Height—81.1 in (2060 mm)
System dimensions (without doors)	<ul style="list-style-type: none"> • Width—23.6 in (600 mm) • Depth— 47.2 in (1200 mm) • Height— 81.1 in (2060 mm)
Weight	350 lbs (158.7 kg)
Weight capacity	3000 lbs (1360.7 kg) static 2500 lbs (1133.9 kg) dynamic tested to 0.8 Grms standard

12.6 Solid state drive specifications

The following table lists the Quantum Corporation qualified solid state drives (SSD) contained within the System Nodes and Storage Nodes.

Table 12-22. 480 GB solid state drive specification summary

Condition	Specification
Model	SanDisk CloudSpeed Eco™ Gen. II SATA SSD
Capacity	480 GB
Dimensions	<ul style="list-style-type: none"> • Width—2.75 in (69.85 mm) • Depth—3.94 in (100.2 mm) • Height—0.282 (7.17 mm)
Hot swappable?	Yes ¹
Operating relative humidity	5% to 95%, non-condensing
Operating temperature (internal)	32°F to 158°F (0°C to 70°C)
Quantity (per component)	<ul style="list-style-type: none"> • Four per System Node • Four per Storage Node
Replacement part number	1EX0221
Type	SATA

1. Only hot swappable after decommissioning.

Table 12-23. 960 GB solid state drive specification summary

Condition	Specification
Model	SanDisk CloudSpeed Eco™ Gen. II SATA SSD
Capacity	960 GB
Dimensions	<ul style="list-style-type: none"> • Width—2.75 in (69.85 mm) • Depth—3.94 in (100.2 mm) • Height—0.282 (7.17 mm)
Hot swappable?	Yes ¹
Operating relative humidity	5% to 95%, non-condensing
Operating temperature	32°F to 158°F (0° C to 70° C)
Part number	1EX0258
Quantity (per component)	Four per System Node
Type	SATA

1. Only hot swappable after decommissioning.

12.7 Storage Enclosure Basic specifications

The following table lists the system specifications for an individual Storage Enclosure Basic.

Table 12-24. Storage Enclosure Specifications

Condition	Specification
Operating relative humidity	8% to 90% non-condensing
Operating temperature	41° to 104°F (5°C to 40°C)
Quantity	Six
Rack units	4U
Relative humidity gradient	30% per hour maximum
Temperature de-rating	33.8°F per 984.2 ft above 9842.5 ft (1°C per 300 m above 3000 m)
Temperature gradient	68°F (20°C)/hour
Weight (per component)	236 lbs (107 kg)
Weight (total for all Storage Enclosure Basics)	1416 lbs (642 kg)

12.8 Storage Node specifications

The following table lists the system specifications for an individual Storage Node.

Table 12-25. Storage Node Specifications

Condition	Specification
Dimensions	<ul style="list-style-type: none"> • Width—17.244 (438 mm) • Depth—24 in (609.6 mm) • Height—1.7in (43.2 mm)
Hot swappable?	No
Operating relative humidity	20% to 85% non-condensing
Operating temperature	41° to 104°F (5°C to 40°C)
Quantity (per system)	Six
Rack Units (U)	1U
Weight (per component)	29 lbs (13.1 kg)
Weight (total for all Storage Nodes)	174 lbs (118.38 kg)

12.9 System Interconnect specifications

The following table lists the system specifications for an individual System Interconnect.

Condition	Specification
Dimensions	<ul style="list-style-type: none"> • Width—17.3 in (438 mm) • Depth—17 in (431 mm) • Height—1.73 in (44 mm)
Hot swappable?	Yes
Operating relative humidity	20% to 85% non-condensing
Operating temperature	41° to 104°F (5°C to 40°C)

Condition	Specification
Quantity (per system)	Two
Rack Units (U)	1U
Weight (individual)	20 lbs (9 kg)
Weight (total for all System Interconnects)	40 lbs (18 kg)

12.10 System Node specifications

The following table lists the system specifications for an individual System Node.

Condition	Specification
Dimensions	<ul style="list-style-type: none">• Width—17.2 in (438 mm)• Depth— 29.2 in (741.6 mm)• Height— 1.73 in (44 mm)
Hot swappable?	No
Operating relative humidity	20% to 85% non-condensing
Operating temperature	41° to 104°F (5°C to 40°C)
Quantity (per system)	Three
Rack Units (U)	1U
Weight (per component)	27 lbs (12.2 kg)
Weight (total for all System Nodes)	81 lbs (36.6 kg)

13 Recommended torque of machined fasteners

The following list is the recommended torque of the machined fasteners being used during replacement or installation of ActiveScale X100 components.

Table 13-26. Recommended torque of machined fasteners (rack components)

Screw size	Torque n-m	Torque in.-lbs
M4	1.46	13
M5	2.82	25

Contacting Quantum

For further assistance, contact the Quantum Contact Support Center.

Region	Support Contact
North America	1-800-284-5101 (toll free) +1-720-249-5700
EMEA	+1-800-7826-8888 (toll free) +49 6131 324 185
Asia Pacific	+800-7826-8887 (toll free) +603-7953-3010
For World Wide Support	https://www.quantum.com/support