

# Quantum<sup>®</sup>

## QXS 12G Site Planning Guide

### 12, 24, and 84-Drive Systems



Trademark Statement:

Artico, Be Certain (and the Q brackets design), DLT, DXi, DXi Accent, DXi V1000, DXi V2000, DXi V4000, DXiV-Series, FlexTier, Lattus, the Q logo, the Q Quantum logo, Q-Cloud, Quantum (and the Q brackets design), the Quantum logo, Quantum Be Certain (and the Q brackets design), Quantum Vision, Scalar, StorageCare, StorNext, SuperLoader, Symform, the Symform logo (and design), vmPRO, and Xcellis are either registered trademarks or trademarks of Quantum Corporation and its affiliates in the United States and/or other countries. All other trademarks are the property of their respective owners. Products mentioned herein are for identification purposes only and may be registered trademarks or trademarks of their respective companies. All other brand names or trademarks are the property of their respective owners. Quantum specifications are subject to change.

Copyright Statement

© 2020 Quantum Corporation. All rights reserved.

Your right to copy this manual is limited by copyright law. Making copies or adaptations without prior written authorization of Quantum Corporation is prohibited by law and constitutes a punishable violation of the law.



# Contents

<b>About This Guide</b> . . . . .	<b>v</b>
Intended audience . . . . .	v
Prerequisites . . . . .	v
Related Documentation . . . . .	vi
Document conventions and symbols . . . . .	vii
<b>QXS System and Cabinet Information</b> . . . . .	<b>1</b>
QXS-312 12G and QXS-324 12G 12G Chassis . . . . .	1
Chassis with Bezels Installed . . . . .	1
Chassis with Bezels Removed . . . . .	2
QXS-412 12G and QXS-424 12G Chassis . . . . .	2
Chassis with Bezels Installed . . . . .	2
Chassis with Bezels Removed . . . . .	3
QXS-484 12G Chassis . . . . .	3
Chassis with Bezels Installed . . . . .	3
Chassis with Drawers Open . . . . .	4
General Cabinet Information . . . . .	5
Standard Cabinet . . . . .	5
Cabinet Height . . . . .	6
Cabinet Vertical Support Rails . . . . .	7
Cabinet Configurations with Chassis and Drives . . . . .	7
QXS-312/324/412/424/484 12G Chassis Supported Configurations . . . . .	8
<b>QXS-312/412 12G System Specifications</b> . . . . .	<b>11</b>
QXS-312/412 12G: 2U12-Drive RAID and Expansion Chassis . . . . .	11
2U12-Drive Chassis . . . . .	11
2U12-Drive RAID and Expansion Chassis Dimensions . . . . .	12
2U12-Drive RAID and Expansion Chassis Weight . . . . .	13
Bezel . . . . .	13
QXS-312 12G 2U12-Drive Chassis Front View . . . . .	13
QXS-312 12G 2U12-Drive RAID Chassis Rear View . . . . .	14
QXS-412 12G 2U12-Drive Chassis Front View . . . . .	15
QXS-412 12G 2U12-Drive RAID Chassis Rear View . . . . .	15
2U12-Drive Expansion Front View . . . . .	16
2U12-Drive Expansion Chassis Rear View . . . . .	16
Power Supply Unit (PSU) . . . . .	18
QXS-312/412 12G RAID and Expansion Physical Requirements . . . . .	18
Composition . . . . .	18
Chassis Designators . . . . .	18
QXS-312/412 12G RAID and Expansion Chassis Dimensions . . . . .	19

QXS-312/412 12G RAID and Expansion Rackmount Chassis Weights . . . . .	19
<b>QXS-324/424 12G System Specifications . . . . .</b>	<b>21</b>
QXS-324/424 12G: 2U24-Drive RAID and Expansion Chassis . . . . .	21
2U24-Drive Chassis . . . . .	21
2U24-Drive RAID and Expansion Chassis Dimensions . . . . .	22
2U24-Drive RAID and Expansion Chassis Weight. . . . .	23
Bezel . . . . .	23
QXS-324 12G 2U24-Drive Chassis Front View . . . . .	24
QXS-324 12G 2U24-Drive RAID Chassis Rear View . . . . .	24
QXS-424 12G 2U24-Drive Chassis Front View . . . . .	25
QXS-424 12G 2U24-Drive RAID Chassis Rear View . . . . .	25
2U24-Drive Expansion Chassis Front View. . . . .	27
2U24-Drive Expansion Chassis Rear View . . . . .	27
Power Supply Unit (PSU). . . . .	29
QXS-324/424 12G RAID and Expansion Physical Requirements . . . . .	29
Composition . . . . .	29
Chassis Designators . . . . .	30
QXS-324/424 12G RAID and Expansion Chassis Dimensions . . . . .	30
QXS-324/424 12G RAID and Expansion Rackmount Chassis Weights . . . . .	30
<b>QXS-484 12G System Specifications . . . . .</b>	<b>33</b>
QXS-484 12G: 5U84-Drive RAID and Expansion Chassis . . . . .	33
5U84-Drive Chassis . . . . .	33
5U84-Drive RAID and Expansion Chassis Dimensions . . . . .	34
5U84-Drive RAID and Expansion Chassis Weight. . . . .	35
Bezel . . . . .	36
5U Chassis Front View. . . . .	36
5U Chassis Drive Slots View . . . . .	36
5U84 RAID Chassis (Rear View/Two CNC Controllers) . . . . .	38
5U84 Expansion Chassis (Rear View). . . . .	39
Power Supply Unit (PSU). . . . .	41
Fans . . . . .	41
QXS-484 12G RAID and Expansion Physical Requirements . . . . .	42
Composition . . . . .	42
Chassis Designators . . . . .	42
QXS-484 12G RAID and Expansion Chassis Dimensions . . . . .	43
QXS-484 12G RAID and Expansion Rackmount Chassis Weights . . . . .	43
<b>Environment and Requirements . . . . .</b>	<b>45</b>
QXS 2U/5U Environmental Requirements. . . . .	45
QXS 2U/5U Ambient Temperature and Humidity Requirements . . . . .	45
QXS 2U/5U Additional Environmental Requirements . . . . .	46
QXS 2U/5U PSU Specifications . . . . .	46
QXS 2U PSU (580W) Specifications . . . . .	47
QXS 5U PSU (2114W) Specifications . . . . .	47
International Standards . . . . .	48
Potential for Radio Frequency Interference . . . . .	48
European Regulations . . . . .	49
Safety Compliance . . . . .	49
EMC Compliance . . . . .	49
AC Power Cords . . . . .	50
Recycling of Waste Electrical and Electronic Equipment (WEEE). . . . .	50



# About This Guide

---

This guide provides site planning information for the following QXS 12G systems:

- QXS-312 12G: 12-Drive (2-Port: FC or iSCSI)
- QXS-324 12G: 24-Drive (2-Port: FC or iSCSI)
- QXS-412 12G: 12-Drive (4-Port: FC or iSCSI)
- QXS-424 12G: 24-Drive (4-Port: FC or iSCSI)
- QXS-484 12G: 84-Drive (4-Port: FC or iSCSI)

---

## Intended audience

This guide is intended for storage customers and technicians.

---

**NOTE:** This guide provides information for site planning at your storage location.

---

---

## Prerequisites

Prerequisites for planning, installing, and using this product include knowledge of:

- Servers and computer networks
- Network administration
- Storage system installation and configuration
- Storage area network (SAN) management and direct attach storage (DAS)
- Converged Network Controllers (CNCs)
- Fibre Channel (FC) protocols
- Serial Attached SCSI (SAS) protocol
- Internet SCSI (iSCSI) protocol

---

## Related Documentation

This section provides related documentation for the QXS 12G systems.

**Table 1** Related Documentation

<b>For Information About</b>	<b>See</b>
Enhancements, known issues, and late-breaking information not included in product documentation	QXS 12G Release Notes
Overview of hardware installation	QXS 12G Quick Start Guide
Product hardware installation and maintenance	QXS 12G Hardware Installation and Maintenance Guide
Obtaining and installing a license to use licensed features	QXS 12G Licensing Guide
Using the web interface to configure and manage the product	QXS 12G Disk Management Utility User Guide
Event codes and recommended actions	QXS 12G Event Descriptions Reference Guide
Using the command-line interface (CLI) to configure and manage the product	QXS 12G CLI Reference Guide
Cabinet information, QXS 12G specifications, and environment and requirements	QXS 12G Site Planning Guide
Regulatory compliance and safety and disposal information	*Product Regulatory Compliance and Safety

\*Printed document included with product.

---

# Document conventions and symbols

**Table 2** Document conventions

Convention	Element
Blue text	Cross-reference links and e-mail addresses
<u>Blue, underlined text</u>	Web site addresses
Bold text	<ul style="list-style-type: none"><li>• Key names</li><li>• Text typed into a GUI element, such as into a box</li><li>• GUI elements that are clicked or selected, such as menu and list items, buttons, and check boxes</li></ul>
Italic text	Text emphasis
Monospace text	<ul style="list-style-type: none"><li>• File and directory names</li><li>• System output</li><li>• Code</li><li>• Text typed at the command-line</li></ul>
<i>Monospace, italic text</i>	<ul style="list-style-type: none"><li>• Code variables</li><li>• Command-line variables</li></ul>
<b>Monospace, bold text</b>	Emphasis of file and directory names, system output, code, and text typed at the command-line

---

**WARNING!** Indicates that failure to follow directions could result in bodily injury.

---

**△ CAUTION:** Indicates that failure to follow directions could result in damage to equipment or data.

---

 **IMPORTANT:** Provides clarifying information or specific instructions.

---

**NOTE:** Provides additional information.

---

 **TIP:** Provides helpful hints and shortcuts.

---





## Chapter 1

# QXS System and Cabinet Information

This chapter provides the following information:

- QXS-312 12G and QXS-324 12G 12G Chassis
- QXS-412 12G and QXS-424 12G Chassis
- QXS-484 12G Chassis
- General Cabinet Information
- QXS-312/324/412/424/484 12G Chassis Supported Configurations

## QXS-312 12G and QXS-324 12G 12G Chassis

This section provides general information for the following chassis:

- QXS-312 12G: 12-Drive System (2-Port: FC or iSCSI)
- QXS-324 12G: 24-Drive System (2-Port: FC or iSCSI)

### Chassis with Bezels Installed

The front of the 12 and 24-drive chassis are 2U high (3.5 inches/88.9mm) and use the same bezel (2U). Refer to [Figure 1](#) for images of the chassis with bezels installed.

**Figure 1** System Front View (with Bezel)



1 QXS-312 12G 12-Drive Chassis (2U high)

2 QXS-324 12G: 24-Drive Chassis (2U high)

## Chassis with Bezels Removed

Figure 2 provides images of the front of the 12 and 24-drive chassis with the bezels removed.

Figure 2 Chassis Front View (Bezel Removed)



### 1 QXS-312 12G: 12-Drive Chassis

- 2U high
- 12 drives installed (Labeled 0-11)
- 2-host ports per controller

### 2 QXS-324 12G: 24-Drive Chassis

- 2U high
- 24 drives installed (Labeled 0-23)
- 2-host ports controller

---

**NOTE:** The QXS-312 12G and QXS-324 12G systems ship with drives installed.

---

## QXS-412 12G and QXS-424 12G Chassis

This section provides general information for the following chassis:

- QXS-412 12G: 12-Drive System (4-Port: FC or iSCSI)
- QXS-424 12G: 24-Drive System (4-Port: FC or iSCSI)

## Chassis with Bezels Installed

The front of the 12 and 24-drive chassis are 2U high (3.5 inches/88.9mm) and use the same bezel (2U). Refer to Figure 3 for images of the chassis with bezels installed.

Figure 3 System Front View (with Bezel)



### 1 QXS-412 12G: 12-Drive Chassis (2U high)

### 2 QXS-424 12G: 24-Drive Chassis (2U high)

## Chassis with Bezels Removed

Figure 4 provides images of the front of the 12 and 24-drive chassis with the bezels removed.

Figure 4 Chassis Front View (Bezel Removed)



### 1 QXS-412 12G: 12-Drive Chassis

- 2U high
- 12 drives installed (Labeled 0-11)
- 4-host ports per controller

### 2 QXS-424 12G: 24-Drive Chassis

- 2U high
- 24 drives installed (Labeled 0-23)
- 4-host ports controller

**NOTE:** The QXS-412 12G and QXS-424 12G systems ship with drives installed.

## QXS-484 12G Chassis

This section provides general information for the QXS-484 12G, 84-Drive System (4-Port: FC or iSCSI).

### Chassis with Bezels Installed

The front of the 84-drive chassis is 5U high (8.75 inches/222.25mm) and uses a bezel for each drawer. Refer to Figure 5 for images of the chassis with bezels installed for Drawer 0 and Drawer 1.

Figure 5 System Front View (with Bezel)

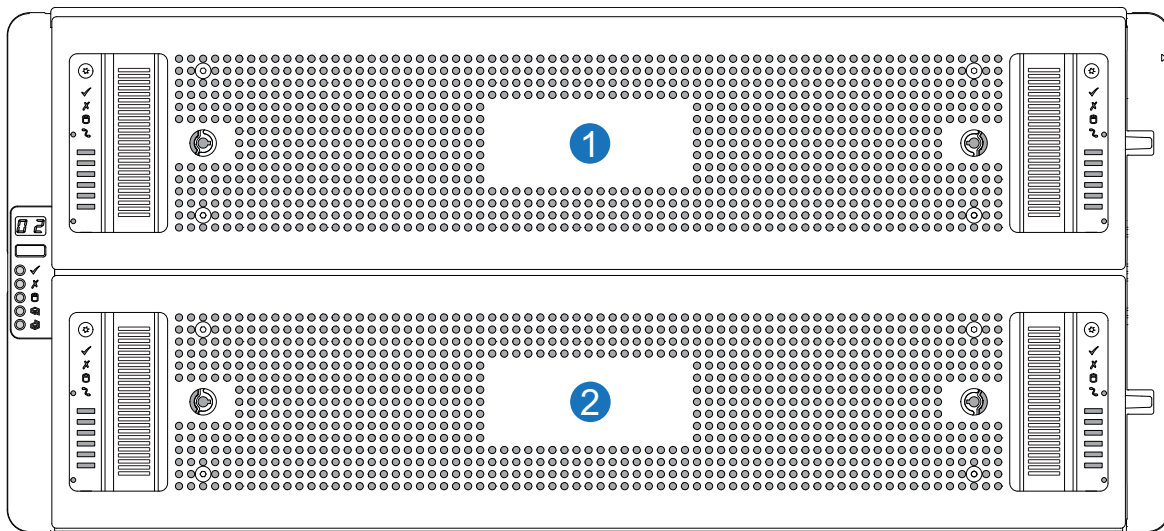

### 1 Drawer 0

### 2 Drawer 1

## Chassis with Drawers Open

**NOTE:** The QXS-484 12G systems ship with **no drives** installed (weight). Drives are shipped within two boxes containing 42 drives within each box.

Figure 6 provides an image of the 84-drive chassis (drive slots view) with the drawer open. There are a total of 84 drive slots in the two drawers.

- Drawer 0 has drive slots 0-41 (42 drives can be installed)
- Drawer 1 has drive slots 42-83 (42 drives can be installed)

**NOTE:** Figure 6 displays the front of the drawer on the left side of the illustration (callout 1). The back of the drawer is on the right side of the illustration (callout 3).

Figure 6 84-Drive Chassis (Drive Slots)

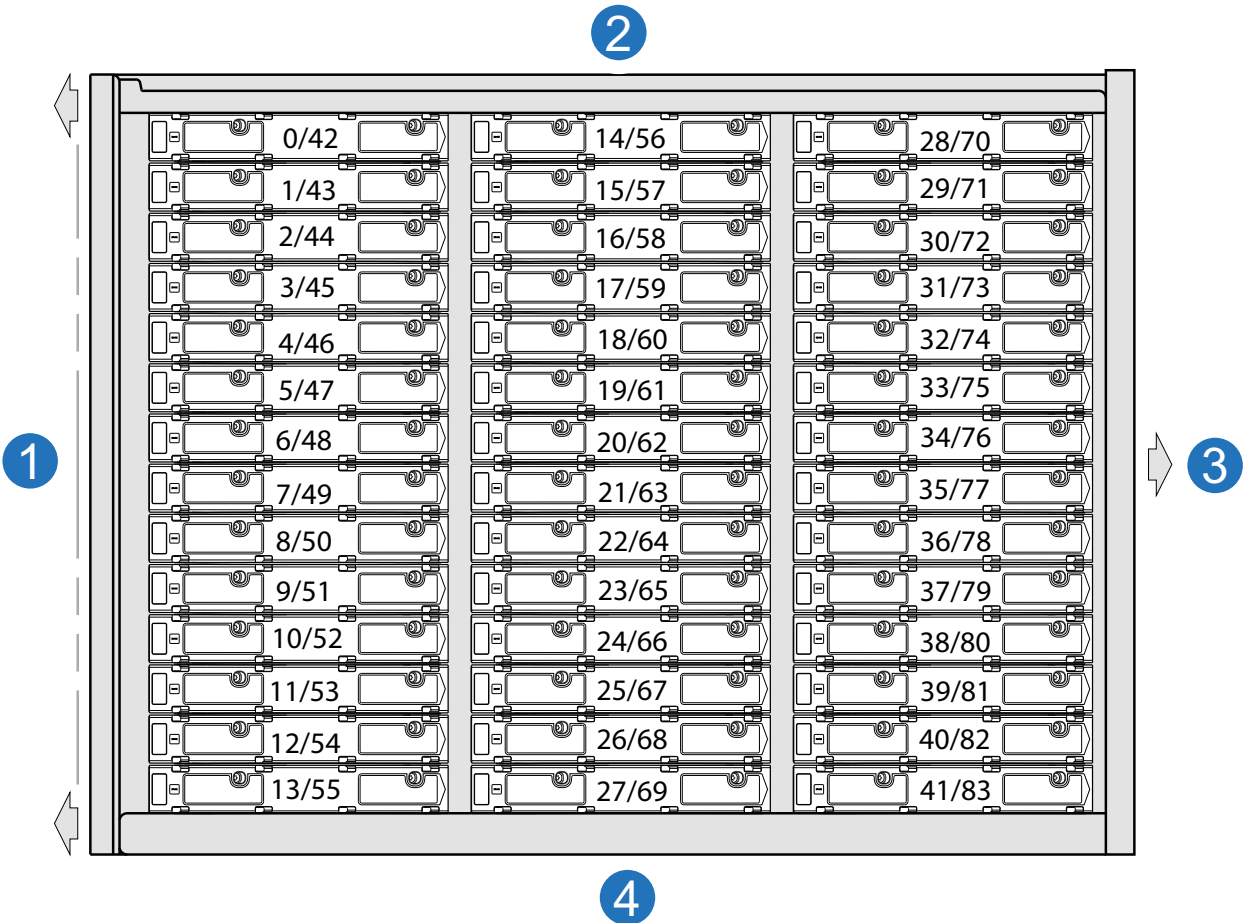

1 Drawer 0/1 Front

2 Drawer 0/1 Left Side

3 Drawer 0/1 Rear (slides into chassis)

4 Drawer 0/1 Right Side

---

# General Cabinet Information

This section includes the following information:

- [Standard Cabinet](#)
- [Cabinet Height](#)
- [Cabinet Vertical Support Rails](#)
- [Cabinet Configurations with Chassis and Drives](#)

## Standard Cabinet

Figure 7 provides an image of a standard cabinet which includes locations of the following:

- Front door
- Rear door
- Vertical support rails
- Air vent

Figure 7 Standard Cabinet

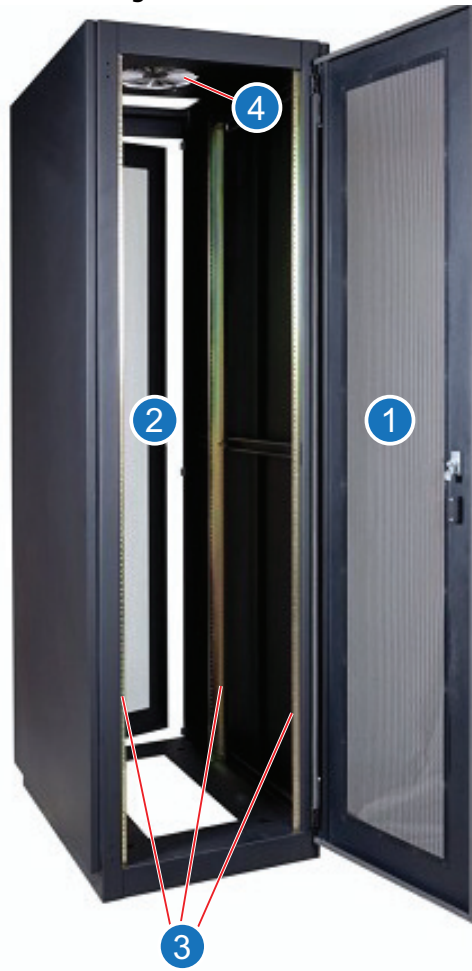

- |                          |             |
|--------------------------|-------------|
| 1 Front door             | 2 Rear door |
| 3 Vertical support rails | 4 Air vent  |

Standard features of the cabinet include:

- Front and rear door that can be closed and locked
- Vertical rails, with mounting holes, to allow installation of storage
- 40U high cabinet and 19 inches/48.3cm wide
- Four rolling coasters/wheels
- Four leveling pads (bottom of cabinet)
- A stabilizing foot (after installation of permanent location)
- Access for storage cabling
- AC or DC power source (2 each)

**WARNING!** Risk of bodily harm and/or injury. Comply with the following:

- Always populate the cabinet from bottom to top to prevent tipping.
- If a cabinet must be moved, use adequate personnel and/or a forklift to relocate the cabinet.
  - Push the cabinet from the front when moving.
  - A fully populated cabinet can weigh almost 3000 pounds (1360.777kg).
  - Cabinets are hard to move, even on a flat surface/floor.
- If moving a cabinet on an incline, always remove the top-half storage arrays/devices to prevent from tipping.

---

**NOTE:** Install the applicable storage rack on the cabinet support rails, then install the chassis/expansion storage unit, and then populate the unit with applicable drives (HDDs or SSDs).

---

Ensure to place the cabinet in a location that allows sufficient space to maintain and service (remove and replace parts) the applicable units within the cabinet.

## Cabinet Height

Cabinets heights might vary. A common cabinet is 40U high.

- A height of 1U equals 1.75-inches (44.45-mm).
- So, a 40U cabinet will have 70 inches (1778 mm/1.778 km) of storage space.

Figure 8 provides a standard cabinet identifying components (callouts) in the front and rear of the unit. Callout descriptions are provided below the illustration.

Figure 8 Front and Rear View of Cabinet

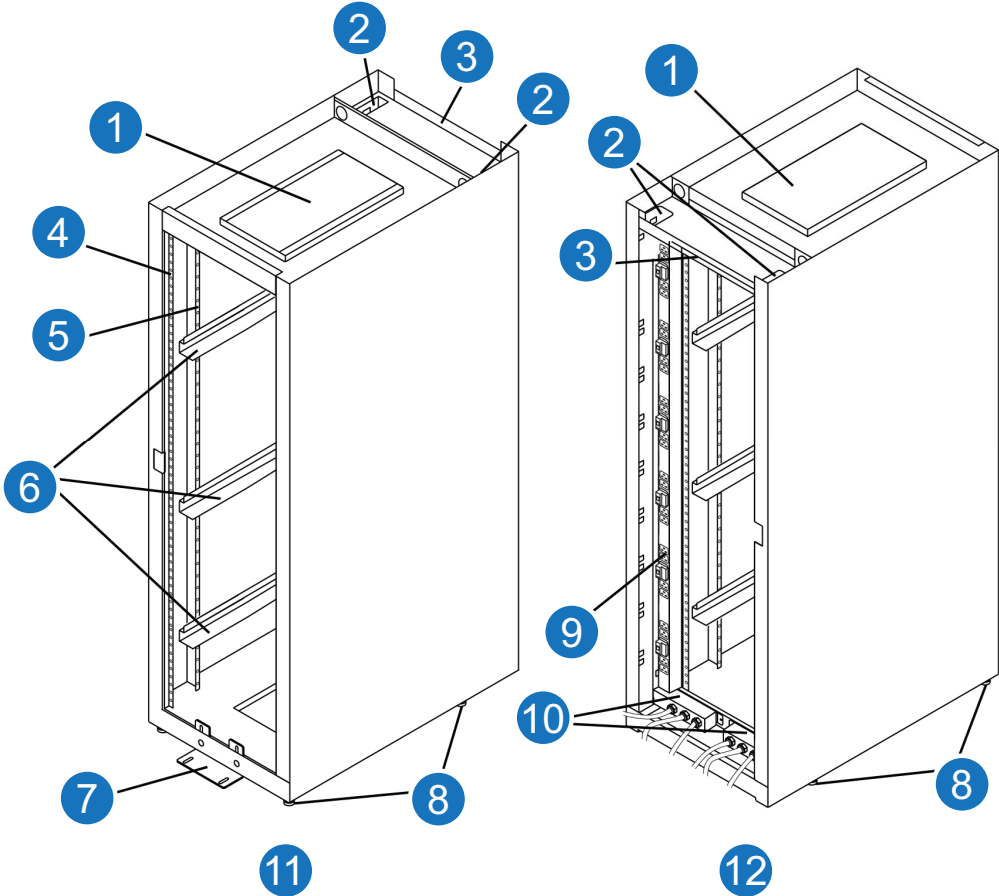

- |                          |                                   |
|--------------------------|-----------------------------------|
| 1 Ventilation cover      | 2 Cable access opening            |
| 3 Rear plate             | 4 Support rails                   |
| 5 Vertical support rails | 6 Mounting rails                  |
| 7 Stability foot         | 8 Leveling feet (variable adjust) |
| 9 Power distribution     | 10 AC power entry boxes           |
| 11 Front of cabinet      | 12 Rear of cabinet                |

### Cabinet Vertical Support Rails

The cabinet vertical support rails can contain square holes, round holes, or pre-tapped holes. Refer to the QXS 12G Hardware Installation and Maintenance Guide for rackmount installation information:

### Cabinet Configurations with Chassis and Drives

Table provides the maximum number of chassis and maximum number of drives that can be installed within a standard 40U cabinet configuration.

**NOTE:** Configurations depend on customer requirements. Refer to [QXS-312/324/412/424/484 12G Chassis Supported Configurations](#) on page 8 for RAID chassis and expansion chassis maximum combinations.

**Table 3** Cabinet Configurations

Chassis Type	Maximum Chassis in Cabinet	Maximum Drives in Cabinet
QXS-312 12G: 12-Drive Chassis (2U, 12 drive)	20	240
QXS-324 12G: 24-Drive Chassis (2U, 24 drive)	20	480
QXS-412 12G: 12-Drive Chassis (2U, 12 drive)	20	240
QXS-424 12G: 24-Drive Chassis (2U, 24 drive)	20	480
QXS-484 12G: 84-Drive Chassis (5U, 84 drive)	8	672

## QXS-312/324/412/424/484 12G Chassis Supported Configurations

**Table 4** identifies the supported QXS-312/324/412/424/484 12G RAID chassis supported configurations. Each system configuration (RAID chassis and expansion chassis) can only contain a specific number of chassis and drives.

**Table 4** QXS-312/324/412/424/484 12G RAID Chassis with Supported Expansion Chassis

Drive Expansion Chassis	QXS-312 12G RAID Chassis Attach	QXS-412 12G RAID Chassis Attach	QXS-324 12G RAID Chassis Attach	QXS-424 12G RAID Chassis Attach	QXS-484 12G RAID Chassis Attach
Drive Form Factor Per Chassis	12-drives (3.5" LFF)	12-drives (3.5" LFF)	24-drives (2.5" SFF)	24-drives (2.5" SFF)	84-drives (2.5" SFF or 3.5" LFF)
2U12 Expansion Chassis	Up to 3	Up to 9	Up to 3	Up to 9	N/A
2U24 Expansion Chassis	Up to 3	Up to 9	Up to 3	Up to 9	N/A
5U84 Expansion Chassis	N/A	Up to 3	N/A	Up to 3	Up to 3

**Table 4** QXS-312/324/412/424/484 12G RAID Chassis with Supported Expansion Chassis (continued)

Drive Expansion Chassis	QXS-312 12G RAID Chassis Attach	QXS-412 12G RAID Chassis Attach	QXS-324 12G RAID Chassis Attach	QXS-424 12G RAID Chassis Attach	QXS-484 12G RAID Chassis Attach
Intermix 2U Expansion Chassis	Up to 3	Up to 9	Up to 3	Up to 9	N/A

**Note:** The 2U12 and 2U24 expansion chassis can be intermixed. However, mixing the 2U12/2U24 expansion chassis and 5U expansion chassis is not supported.

**CAUTION:** Ensure that the cabinet weight (populated with chassis, drives, units) does not exceed the floor loading specifications.

You should record the total weight of your applicable cabinets (with contents). Use this information to check floor loading restrictions and/or elevator weight restrictions.

**Figure 9** provides a standard cabinet fully populated with storage and servers (front of cabinet, with door closed).

**Figure 9** Fully Populated Cabinet







## Chapter 2

# QXS-312/412 12G System Specifications

---

This chapter provides the following information:

- [QXS-312/412 12G: 2U12-Drive RAID and Expansion Chassis](#)
- [QXS-312/412 12G RAID and Expansion Physical Requirements](#)
- [QXS-312/412 12G RAID and Expansion Chassis Dimensions](#)
- [QXS-312/412 12G RAID and Expansion Rackmount Chassis Weights](#)

---

## QXS-312/412 12G: 2U12-Drive RAID and Expansion Chassis

This section provides 2U12-drive RAID and expansion chassis system component/CRU information. The front of the QXS-312 12G and QXS-412 12G look the same.

### 2U12-Drive Chassis

Figure 10 provides a front view of the 2U12-drive chassis. Chassis is shipped with drives installed.

Figure 10 2U12-Drive Chassis

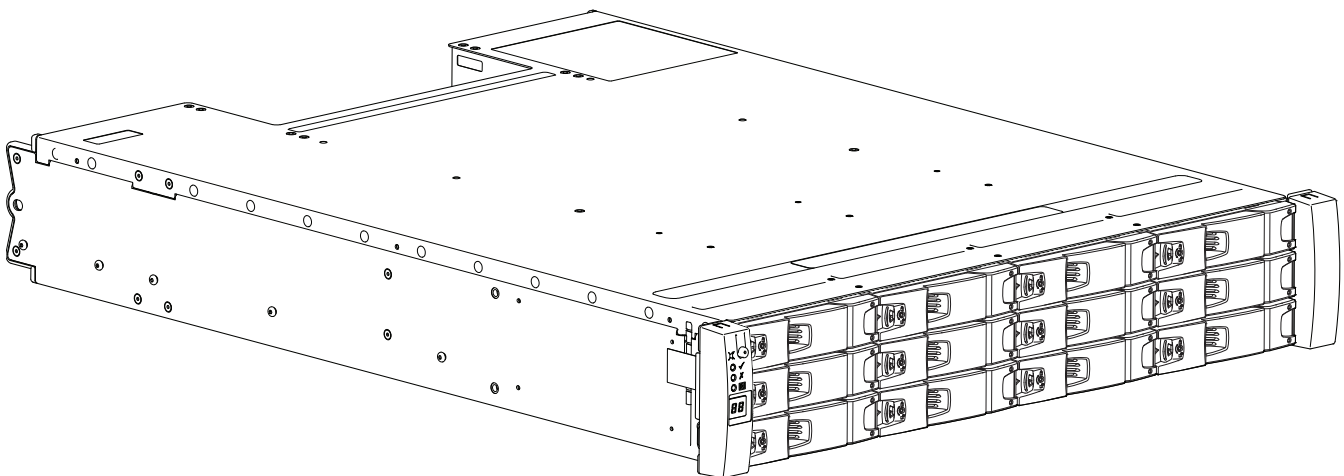

The 2U12 chassis can be configured as a RAID chassis or an expansion chassis.

Table 5 provides the QXS-312/412 12G chassis components/CRUs.

**Table 5** Chassis Components/CRUs

Product	Configuration	Drives	PSUs <sup>1</sup>	I/O Modules	Bezel <sup>4</sup>
2U12 RAID Chassis	12Gb/s direct dock drives	12 LFF (3.5" SATA)	2	2 Controllers <sup>2</sup>	1
2U12 Expansion Chassis	12Gb/s direct dock drives	12 LFF (3.5" SATA)	2	2 Expansion IOMs <sup>3</sup>	1

PSUs<sup>1</sup>: Redundant PSUs must be compatible modules of the same type (both AC). Power cords are shipped with all chassis.

Controllers<sup>2</sup>:

- The QXS-312 12G system has only 2-host ports per controller.
- The QXS-412 12G system has 4-host ports per controller.

IOMs<sup>3</sup>: Supported expansion IOMs are used in expansion chassis for adding storage.

Bezel<sup>4</sup>: Bezels ship as follows:

- The 2U12 chassis has a bezel shipped in a separate box and must be installed on site.
- The 2U24 chassis has a bezel shipped in a separate box and must be installed on site.
- The 5U84 chassis ships with the bezel installed.

Note: Ethernet cables are shipped with all RAID chassis.

**CAUTION:** The RAID chassis supports dual-controller configuration only.

- If a partner controller fails, the storage system will fail over and run on a single controller module until the redundancy is restored.

- A RAID controller or expansion IOM must be installed in IOM slot to ensure sufficient air flow through the chassis during operation.

## 2U12-Drive RAID and Expansion Chassis Dimensions

Table 6 identifies dimensions of the QXS-312/412 12G, 2U12-drive RAID and expansion chassis.

**Table 6** Chassis Dimensions

Specification	Metric Unit	Imperial Unit
Overall chassis height (2U)	87.9 mm	3.46 in
Width across mounting flange (located on front of chassis)	483 mm	19.01 in
Width across body of chassis	443 mm	17.44 in
Depth from face of mounting flange to back of chassis body	576.8 mm	22.71 in
Depth from face of mounting flange to rearmost chassis extremity	602.9 mm	23.74 in
Depth from face of Ops panel to rearmost chassis extremity	629.6 mm	24.79 in

**Note:** The 2U12 chassis uses 3.5" LFF disks.

## 2U12-Drive RAID and Expansion Chassis Weight

Table 7 identifies the weight of the QXS-312/412 12G, 2U12-drive RAID and expansion chassis.

**Table 7** Chassis Weights

CRU/Component	2U12 (kg/lb)
Storage chassis (empty)	4.8/10.56
Disk drive carrier	0.9/1.98
Dummy disk drive carrier (air management sled)	0.05/0.11
2U Power Supply Unit (PSU)	3.5/7.7
Controller (module in RAID chassis)	2.6/5.8
Expansion IOM (module in expansion chassis)	1.5/3.3
RAID chassis (fully populated with modules: maximum weight)	32/71
Expansion chassis (fully populated with modules: maximum weight)	28/62

**Note 1:** Weights shown are nominal, and subject to variances.

**Note 2:** 2U rail kits add between 2.8 kg (6.2 lb) and 3.4 kg (7.4 lb) to the aggregate chassis weight.

**Note 3:** Weights may vary due to different power supplies, controllers/expansion IOMs, and differing calibrations between scales.

**Note 4:** Weights may vary due to actual number and type of drives (SAS or SSD) and air management modules installed.

## Bezel

The 2U12 drive chassis includes a bezel sub-assembly that attaches to the front panel of the chassis. The bezel, comprised of a vented cover attached to an electro-magnetic interference (EMI) shield, is pre-assembled and packed within a box contained in the enclosure master shipping container.

Instructions for attaching/removing the bezel are provided in the QXS 12G Hardware Installation and Maintenance Guide.

**CAUTION:** The bezel should be properly installed while the chassis is in operation to ensure adequate EMI protection for the drives.

## QXS-312 12G 2U12-Drive Chassis Front View

Integers on the drives indicate drive slot numbering sequence (0-11). Figure 11 provides a front view of the 2U12-drive chassis.

**Figure 11** 2U12-Drive Chassis Front View

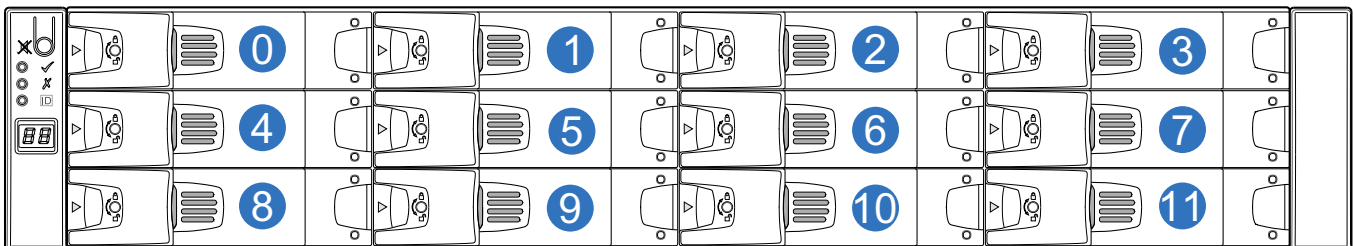

# QXS-312 12G 2U12-Drive RAID Chassis Rear View

Refer to the numbers on the CRUs, [Figure 12](#), and the table to identify components within the 2U chassis. PSU and controller modules are available as CRUs. The RAID chassis use 2-port controller modules. Use expansion chassis for optionally added storage.

## RAID Chassis (CNC Controllers and 2 FC/iSCSI ports)

[Figure 12](#) provides a rear view of the 2U12-drive RAID chassis with two CNC controllers (2 FC/iSCSI ports).

Figure 12 2U12-Drive RAID Chassis (2 FC/iSCSI ports)

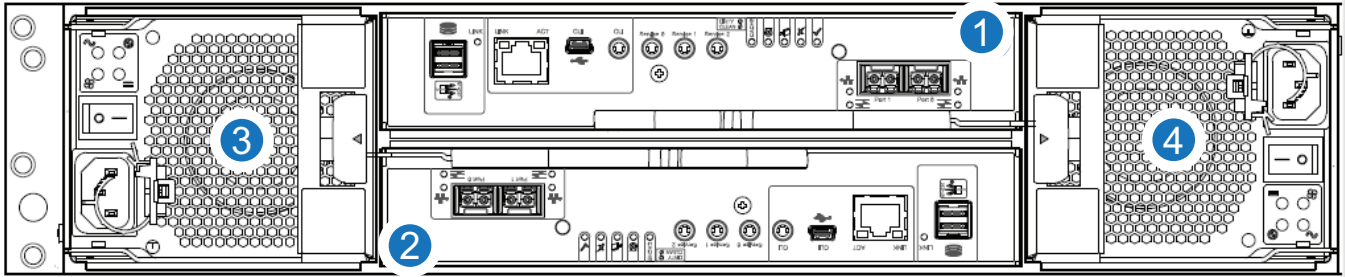

- |   |              |   |              |
|---|--------------|---|--------------|
| 1 | Controller A | 2 | Controller B |
| 3 | PSU0         | 4 | PSU1         |

## CNC FC/iSCSI Controller

Callout 1, [Figure 12](#), is the Controller A location. Callout 2, [Figure 12](#), is the Controller B location. Both controllers are shown in the closed/locked position.

[Figure 13](#) provides a rear view of the CNC FC/iSCSI controller used in the 2U12-drive systems. You can configure the CNC host interface ports (Ports 0 and 1) with 8/16Gb/s FC SFPs; 10GbE iSCSI SFPs; or 1Gb/s RJ-45 SFPs.

Figure 13 CNC FC/iSCSI Controller

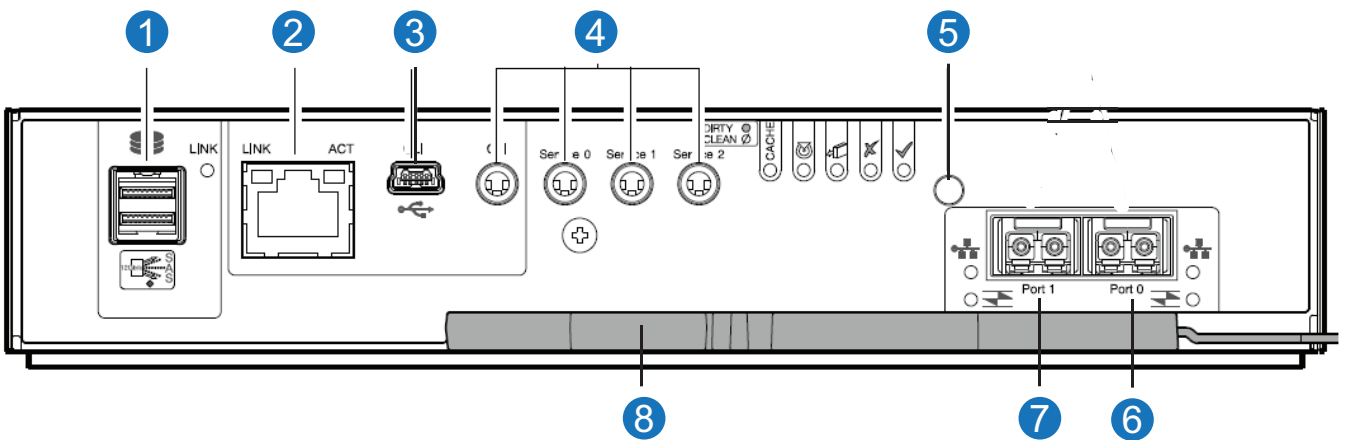

- |   |            |   |                             |
|---|------------|---|-----------------------------|
| 1 | SAS Port   | 2 | Ethernet Port               |
| 3 | USB Port   | 4 | Serial Ports (service only) |
| 5 | Reset      | 6 | CNC Port 0                  |
| 7 | CNC Port 1 | 8 | Lock/Release Handle         |

## QXS-412 12G 2U12-Drive Chassis Front View

Integers on the drives indicate drive slot numbering sequence (0-11). [Figure 14](#) provides a front view of the 2U12-drive chassis.

**Figure 14** 2U12-Drive Chassis Front View

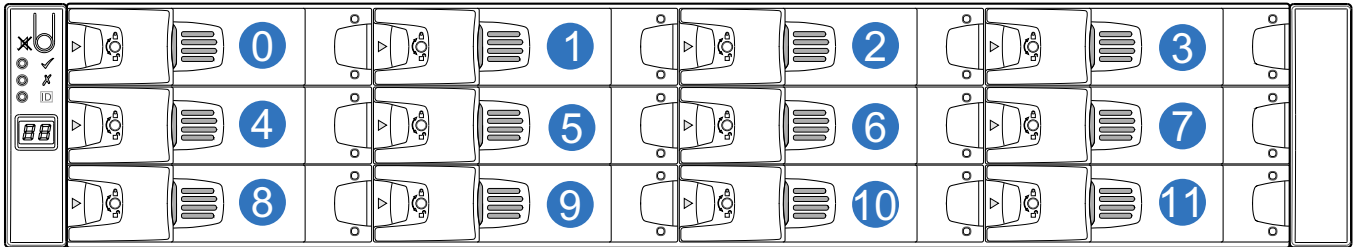

## QXS-412 12G 2U12-Drive RAID Chassis Rear View

Refer to the numbers on the CRUs, [Figure 15](#), and the table to identify components within the 2U chassis. PSU and controller modules are available as CRUs. The RAID chassis use 4-port controller modules. Use expansion chassis for optionally added storage.

### RAID Chassis (CNC Controllers and 4 FC/iSCSI ports)

[Figure 15](#) provides a rear view of the 2U12-drive RAID chassis with two CNC controllers (4 FC/iSCSI ports).

**Figure 15** 2U12-Drive RAID Chassis (4 FC/iSCSI ports)

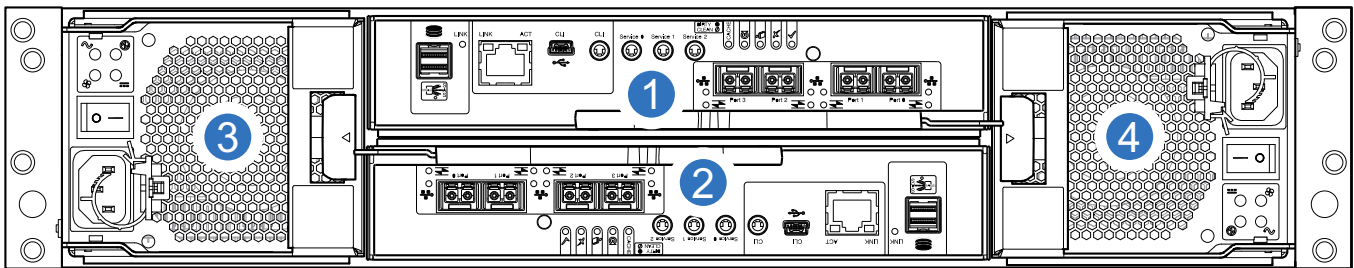

- |   |              |   |              |
|---|--------------|---|--------------|
| 1 | Controller A | 2 | Controller B |
| 3 | PSU0         | 4 | PSU1         |

### CNC FC/iSCSI Controller

Callout 1, [Figure 15](#), is the Controller A location. Callout 2, [Figure 15](#), is the Controller B location. Both controllers are shown in the closed/locked position.

Figure 16 provides a rear view of the CNC FC/iSCSI controller used in the 2U12-drive systems. You can configure the CNC host interface ports (Ports 0, 1, 2 and 3) with 8/16Gb/s FC SFPs; 10GbE iSCSI SFPs; or 1Gb/s RJ-45 SFPs.

Figure 16 CNC FC/iSCSI Controller

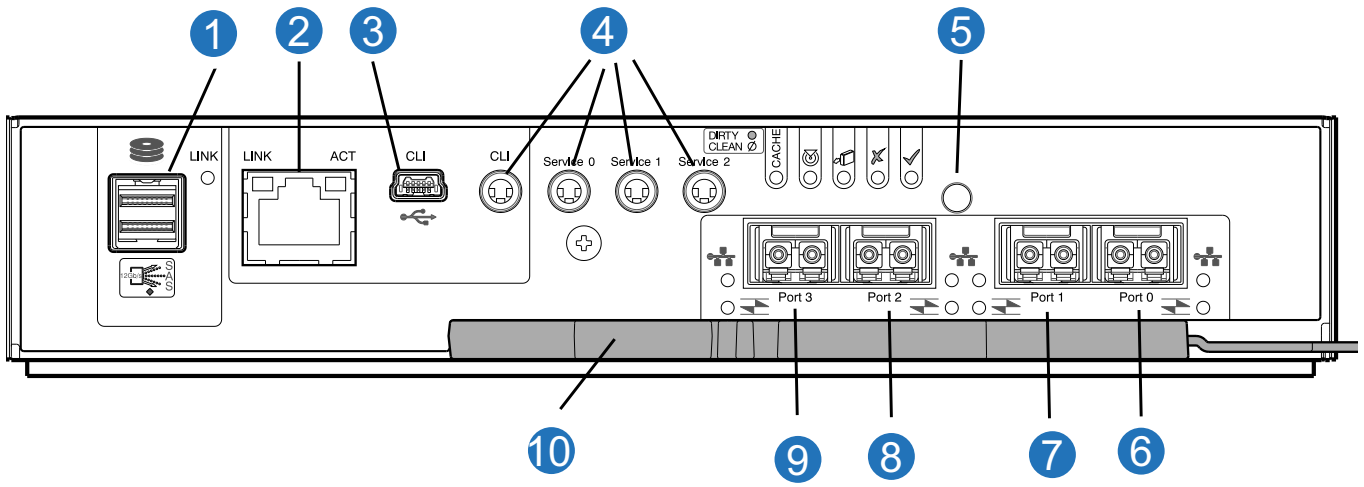

- |   |            |    |                             |
|---|------------|----|-----------------------------|
| 1 | SAS Port   | 2  | Ethernet Port               |
| 3 | USB Port   | 4  | Serial Ports (service only) |
| 5 | Reset      | 6  | CNC Port 0                  |
| 7 | CNC Port 1 | 8  | CNC Port 2                  |
| 9 | CNC Port 3 | 10 | Lock/Release Handle         |

## 2U12-Drive Expansion Front View

Integers on the drives indicate drive slot numbering sequence (0-11). Figure 17 provides a front view of the 2U12-drive chassis.

Figure 17 2U12-Drive Chassis Front View

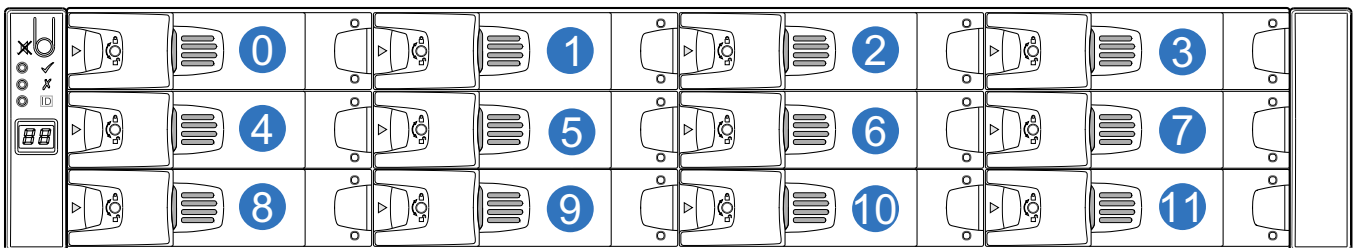

## 2U12-Drive Expansion Chassis Rear View

The top middle slot, Figure 18, is the Expansion IOM A location. The lower middle slot is the Expansion IOM B location. Both IOMs are shown in the closed/locked position.

## Expansion Chassis

Figure 18 provides a rear view of the 2U12-drive expansion chassis rear panel. The expansion chassis attaches to the RAID chassis for additional storage.

Figure 18 2U12 Expansion Chassis Rear View

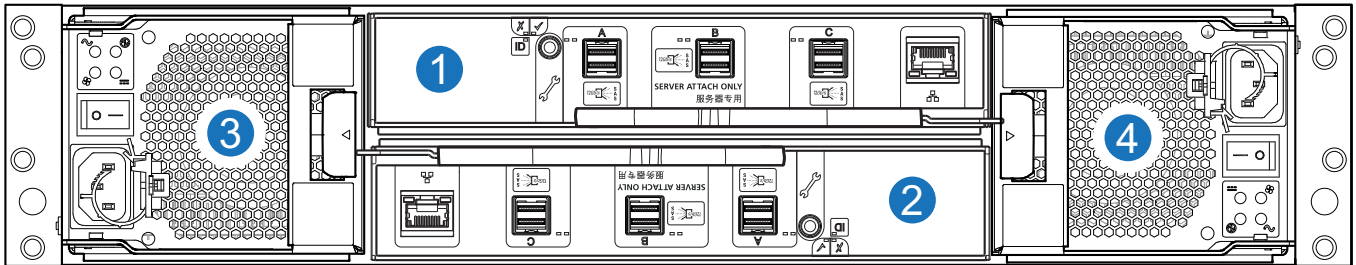

1	IOM A	2	IOM B
3	PSU0	4	PSU1

## Expansion Chassis IOM

Figure 19 provides a rear view of the expansion chassis IOM used in the 2U12-drive systems. Ports A/B/C ship configured with 12Gb/s HD mini-SAS (SFF-8644) external connectors.

Figure 19 Expansion Chassis IOM

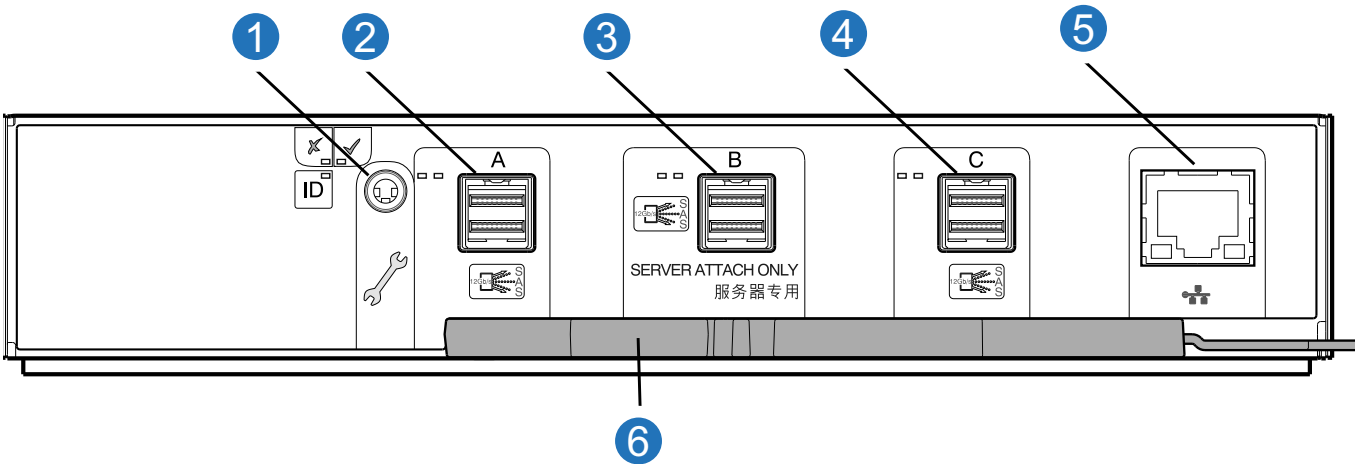

1	SAS Port	2	SAS Port A
3	SAS Port B	4	SAS Port C
5	Ethernet Port	6	Lock/Release Handle

### IMPORTANT: RAID chassis and expansion configurations:

- When the expansion chassis shown above (Figure 18) is used with RAID chassis for adding storage, its middle HD mini-SAS expansion port ("B") is disabled by the firmware.
- The Ethernet port on the expansion module is not used in RAID chassis and expansion configurations, and is disabled.

## Power Supply Unit (PSU)

Figure 20 provides an illustration of the PSU used in the RAID chassis and the expansion chassis. They are identical in the 12-drive and 24-drive chassis. Figure 20 shows an example of a PSU oriented for use in the left PSU Slot 0 of the RAID or expansion chassis.

Figure 20 PSU

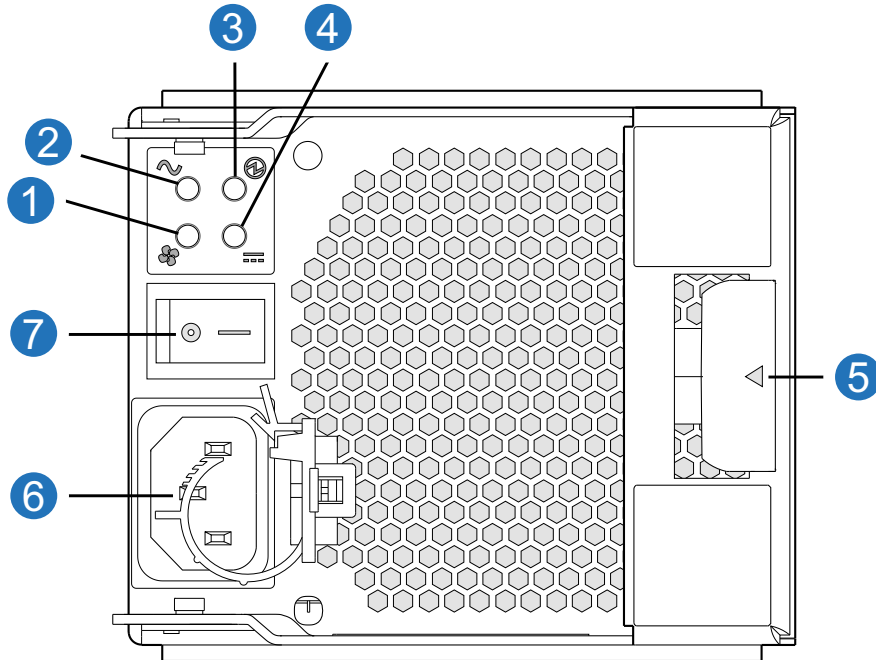

- |   |                     |   |               |
|---|---------------------|---|---------------|
| 1 | Fan Fail LED        | 2 | AC Fail LED   |
| 3 | PSU OK LED          | 4 | DC Fail LED   |
| 5 | Release/Lock Handle | 6 | Power Connect |

---

## QXS-312/412 12G RAID and Expansion Physical Requirements

The floor space at the installation site must be strong enough to support the combined weight of the rack, 2U12 RAID chassis, 2U12 expansion chassis, and any additional equipment. The site also requires sufficient space for installation, operation, and servicing of the chassis, together with sufficient ventilation to allow a free flow of air to all chassis.

### Composition

The RAID chassis and expansion chassis are comprised of sheet steel that is bonded together using rivets, welding, and other forced contact methods. The metal surfaces are free from non-conductive coatings and paint.

### Chassis Designators

The RAID and expansion chassis designators are as follows:

- 2U12 chassis

- “2U12” denotes the 3.5” chassis (with controller or expansion modules)
- The 2U12 chassis ships with 3.5” LFF drives installed.
- Two controller modules or two expansion modules per chassis
- Two power supplies per chassis

## QXS-312/412 12G RAID and Expansion Chassis Dimensions

Table 8 provides the 2U12 RAID and expansion chassis dimensions.

**Table 8** 2U12 RAID and Expansion Chassis Dimensions

Specification	Metric Unit	Imperial Unit
Overall chassis height (2U)	87.9 mm	3.46 in
Width across mounting flange (located on front of chassis)	483 mm	19.01 in
Width across body of chassis	443 mm	17.44 in
Depth from face of mounting flange to back of chassis body	576.8 mm	22.71 in
Depth from face of mounting flange to rearmost chassis extremity	602.9 mm	23.74 in
Depth from face of Ops panel to rearmost chassis extremity	629.6 mm	24.79 in

**Note:** The 2U12 chassis uses 3.5" LFF drives. Chassis is shipped fully populated with drives installed.

## QXS-312/412 12G RAID and Expansion Rackmount Chassis Weights

Table 9 provides the chassis weights for the 2U12 RAID and expansion chassis.

**Table 9** 2U12 RAID and Expansion Chassis Weights

CRU/Component	2U12 (kg/lb)
Storage chassis (empty)	4.8/10.56
Disk drive carrier	0.9/1.98
Dummy disk drive carrier (air management sled)	0.05/0.11
2U Power Supply Unit (PSU)	3.5/7.7
Controller (module in RAID chassis)	2.6/5.8
Expansion IOM (module in expansion chassis)	1.5/3.3
RAID chassis (fully populated with modules: maximum weight)	32/71
Expansion chassis (fully populated with modules: maximum weight)	28/62

**Note 1:** Weights shown are nominal, and subject to variances.

**Note 2:** 2U rail kits add between 2.8 kg (6.2 lb) and 3.4 kg (7.4 lb) to the aggregate chassis weight.

**Table 9** (continued) 2U12 RAID and Expansion Chassis Weights

CRU/Component	2U12 (kg/lb)
<b>Note 3:</b> Weights may vary due to different power supplies, controllers/expansion IOMs, and differing calibrations between scales.	
<b>Note 4:</b> Weights may vary due to actual number and type of drives (SAS, SATA, or SSD) and air management modules installed.	



## Chapter 3

# QXS-324/424 12G System Specifications

This chapter provides the following information:

- QXS-324/424 12G: 2U24-Drive RAID and Expansion Chassis
- QXS-324/424 12G RAID and Expansion Physical Requirements
- QXS-324/424 12G RAID and Expansion Chassis Dimensions
- QXS-324/424 12G RAID and Expansion Rackmount Chassis Weights

## QXS-324/424 12G: 2U24-Drive RAID and Expansion Chassis

This section provides 2U24-drive RAID and expansion chassis system component/CRU information. The front of the QXS-324 12G and QXS-424 12G look the same.

### 2U24-Drive Chassis

Figure 21 provides a front view of the 2U24-drive chassis. Chassis is shipped with drives installed.

Figure 21 2U24-Drive Chassis

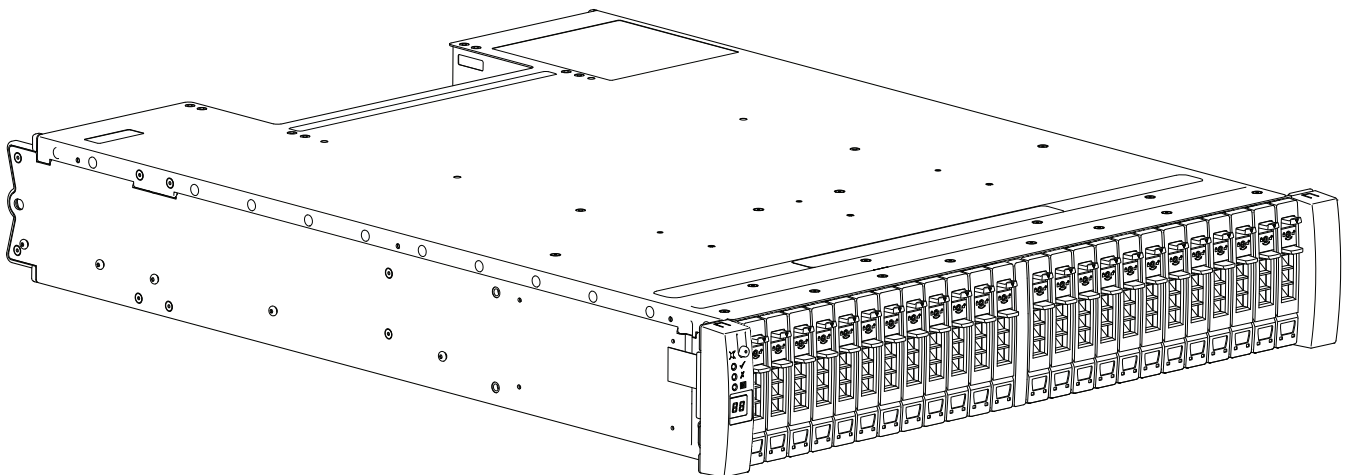

The 2U24 chassis can be configured as a RAID chassis or an expansion chassis.

Table 10 provides the QXS-324/424 12G chassis components/CRUs.

**Table 10** Chassis Components/CRUs

Product	Configuration	Drives	PSUs <sup>1</sup>	I/O Modules	Bezel <sup>4</sup>
2U24 RAID Chassis	12Gb/s direct dock drives	24 SFF <ul style="list-style-type: none"> <li>• 2.5" SAS</li> <li>• 2.5" SATA</li> </ul>	2	2 Controllers <sup>2</sup>	1
2U24 Expansion Chassis	12Gb/s direct dock drives	24 SFF <ul style="list-style-type: none"> <li>• 2.5" SAS</li> <li>• 2.5" SATA</li> </ul>	2	2 Expansion IOMs <sup>3</sup>	1

PSUs<sup>1</sup>: Redundant PSUs must be compatible modules of the same type (both AC). Power cords are shipped with all chassis.

Controllers<sup>2</sup>:

- The QXS-324 12G system has only 2-host ports per controller.
- The QXS-424 12G system has 4-host ports per controller.

IOMs<sup>3</sup>: Supported expansion IOMs are used in expansion chassis for adding storage.

Bezel<sup>4</sup>: Bezels ship as follows:

- The 2U12 chassis has a bezel shipped in a separate box and must be installed on site.
- The 2U24 chassis has a bezel shipped in a separate box and must be installed on site.
- The 5U84 chassis ships with the bezel installed.

Note: Ethernet cables are shipped with all RAID chassis.

**CAUTION:** The RAID chassis supports dual-controller configuration only.

- If a partner controller fails, the storage system will fail over and run on a single controller module until the redundancy is restored.

- A RAID controller or expansion IOM must be installed in IOM slot to ensure sufficient air flow through the chassis during operation.

## 2U24-Drive RAID and Expansion Chassis Dimensions

Table 11 identifies dimensions of the QXS-324/424 12G RAID and expansion chassis.

**Table 11** Chassis Dimensions

Specification	Metric Unit	Imperial Unit
Overall chassis height (2U)	87.9 mm	3.46 in
Width across mounting flange (located on front of chassis)	483 mm	19.01 in
Width across body of chassis	443 mm	17.44 in
Depth from face of mounting flange to back of chassis body	576.8 mm	22.71 in
Depth from face of mounting flange to rearmost chassis extremity	602.9 mm	23.74 in

**Table 11** (continued)Chassis Dimensions

Specification	Metric Unit	Imperial Unit
Depth from face of Ops panel to rearmost chassis extremity	629.6 mm	24.79 in

**Note:** The 2U24 chassis uses 2.5" SFF disks.

## 2U24-Drive RAID and Expansion Chassis Weight

Table 12 identifies the weight of the QXS-324/424 12G RAID and expansion chassis.

**Table 12** Chassis Weights

CRU/Component	2U24 (kg/lb)
Storage chassis (empty)	4.8/10.56
Disk drive carrier	0.3/0.66
Dummy disk drive carrier (air management sled)	0.05/0.11
2U Power Supply Unit (PSU)	3.5/7.7
5U Power Supply Unit (PSU)	-
5U Fan	-
Controller (module in RAID chassis)	2.6/5.8
Expansion IOM (module in expansion chassis)	1.5/3.3
RAID chassis (fully populated with modules: maximum weight)	30/66
Expansion chassis (fully populated with modules: maximum weight)	25/55

**Note 1:** Weights shown are nominal, and subject to variances.

**Note 2:** 2U rail kits add between 2.8 kg (6.2 lb) and 3.4 kg (7.4 lb) to the aggregate chassis weight.

**Note 3:** Weights may vary due to different power supplies, controllers/expansion IOMs, and differing calibrations between scales.

**Note 4:** Weights may vary due to actual number and type of drives (SAS or SSD) and air management modules installed.

## Bezel

The 2U24 drive chassis includes a bezel sub-assembly that attaches to the front panel of the chassis. The bezel, comprised of a vented cover attached to an electro-magnetic interference (EMI) shield, is pre-assembled and packed within a box contained in the enclosure master shipping container.

Instructions for attaching/removing the bezel are provided in the QXS 12G Hardware Installation and Maintenance Guide.

**CAUTION:** The bezel should be properly installed while the chassis is in operation to ensure adequate EMI protection for the drives.

## QXS-324 12G 2U24-Drive Chassis Front View

Integers on the drives indicate drive slot numbering sequence (0-23). [Figure 22](#) provides a front view of the 2U24-drive chassis.

**Figure 22** 2U24-Drive Chassis Front View

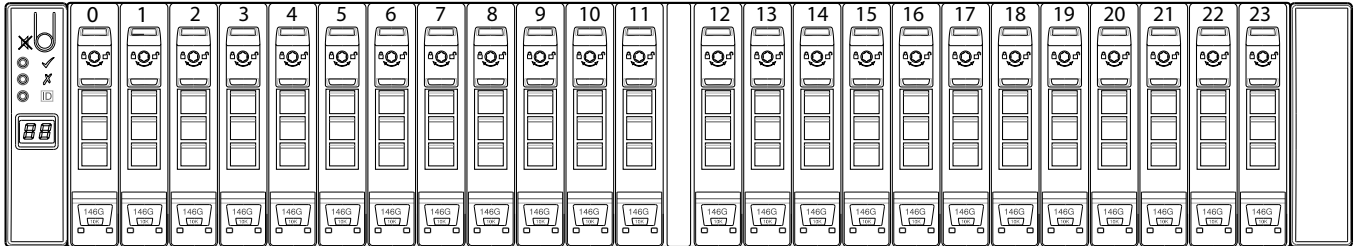

## QXS-324 12G 2U24-Drive RAID Chassis Rear View

Refer to the numbers on the CRUs, [Figure 23](#), and the table to identify components within the 2U24 chassis. PSU and controller modules are available as CRUs. The RAID chassis use 2-port controller modules. Use expansion chassis for optionally added storage.

### RAID Chassis (CNC Controllers and 2FC/iSCSI ports)

[Figure 23](#) provides a rear view of the 2U24-drive RAID chassis with two CNC controllers (2 FC/iSCSI ports).

**Figure 23** 2U24-Drive RAID Chassis (2 FC/iSCSI ports)

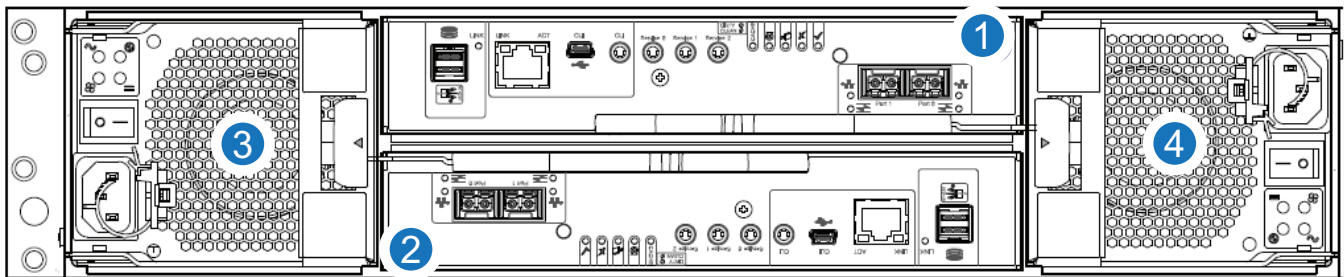

- |   |              |   |              |
|---|--------------|---|--------------|
| 1 | Controller A | 2 | Controller B |
| 3 | PSU0         | 4 | PSU1         |

### CNC FC/iSCSI Controller

Callout 1, [Figure 23](#), is the Controller A location. Callout 2, [Figure 23](#), is the Controller B location. Both controllers are shown in the closed/locked position.

Figure 24 provides a rear view of the CNC FC/iSCSI controller used in the 2U24-drive systems. You can configure the CNC host interface ports (Ports 0 and 1) with 8/16Gb/s FC SFPs; 10GbE iSCSI SFPs; or 1Gb/s RJ-45 SFPs.

Figure 24 CNC FC/iSCSI Controller

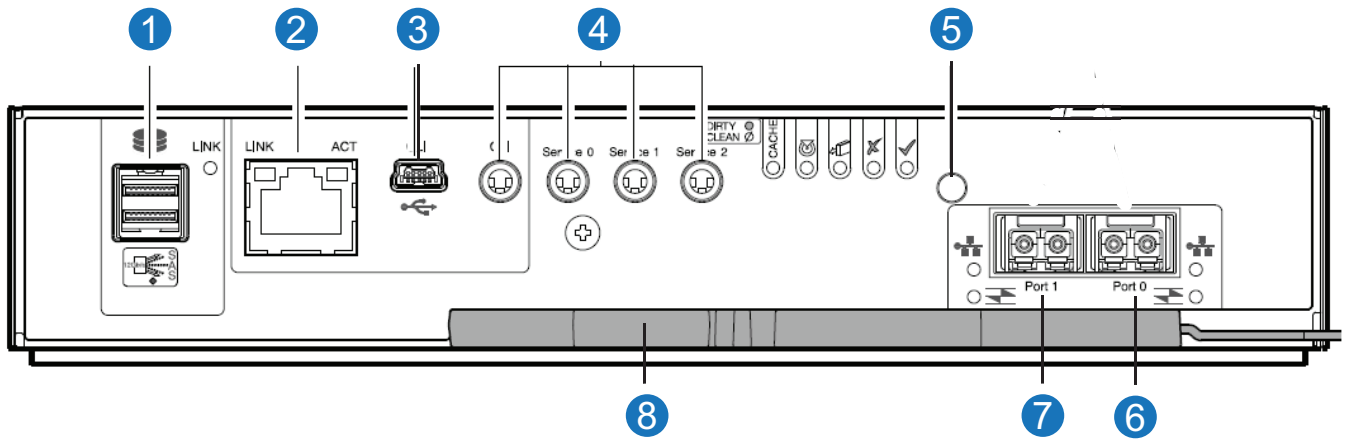

- |   |            |   |                             |
|---|------------|---|-----------------------------|
| 1 | SAS Port   | 2 | Ethernet Port               |
| 3 | USB Port   | 4 | Serial Ports (service only) |
| 5 | Reset      | 6 | CNC Port 0                  |
| 7 | CNC Port 1 | 8 | Lock/Release Handle         |

## QXS-424 12G 2U24-Drive Chassis Front View

Integers on the drives indicate drive slot numbering sequence (0-23). Figure 25 provides a front view of the 2U24-drive chassis.

Figure 25 2U24-Drive Chassis Front View

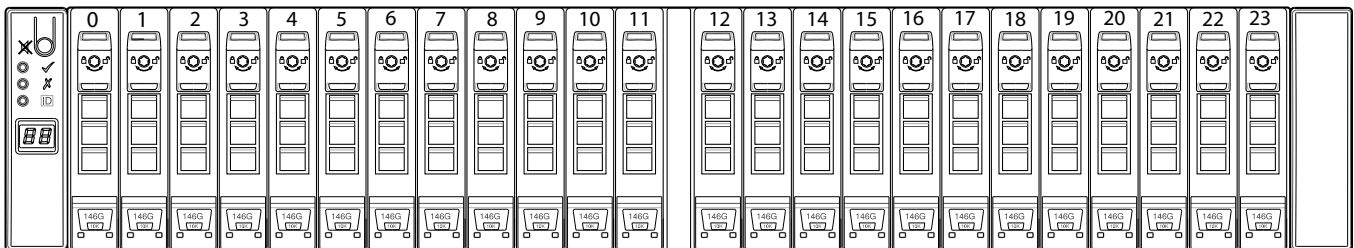

## QXS-424 12G 2U24-Drive RAID Chassis Rear View

Refer to the numbers on the CRUs, Figure 26, and the table to identify components within the 2U24 chassis. PSU and controller modules are available as CRUs. The RAID chassis use 4-port controller modules. Use expansion chassis for optionally added storage.

## RAID Chassis (CNC Controllers and 4 FC/iSCSI ports)

Figure 26 provides a rear view of the 2U24-drive RAID chassis with two CNC controllers (4 FC/iSCSI ports).

Figure 26 2U24-Drive RAID Chassis (4 FC/iSCSI ports)

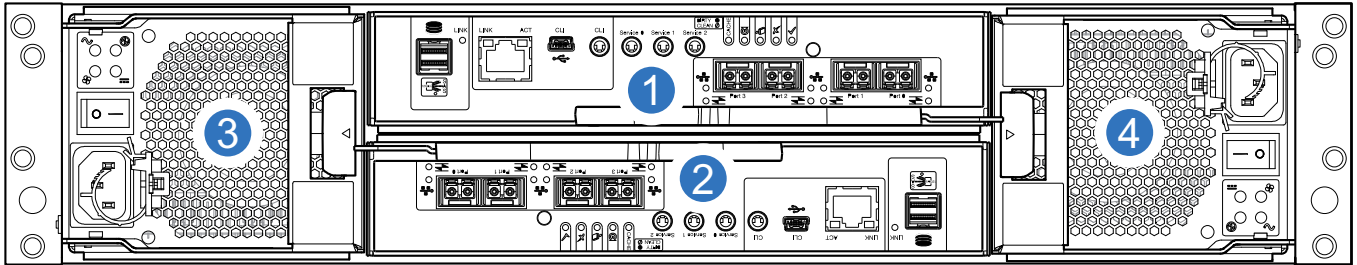

- |   |              |   |              |
|---|--------------|---|--------------|
| 1 | Controller A | 2 | Controller B |
| 3 | PSU0         | 4 | PSU1         |

## CNC FC/iSCSI Controller

Callout 1, Figure 26, is the Controller A location. Callout 2, Figure 26, is the Controller B location. Both controllers are shown in the closed/locked position.

Figure 27 provides a rear view of the CNC FC/iSCSI controller used in the 2U24-drive systems. You can configure the CNC host interface ports (Ports 0, 1, 2 and 3) with 8/16Gb/s FC SFPs; 10GbE iSCSI SFPs; or 1Gb/s RJ-45 SFPs.

Figure 27 CNC FC/iSCSI Controller

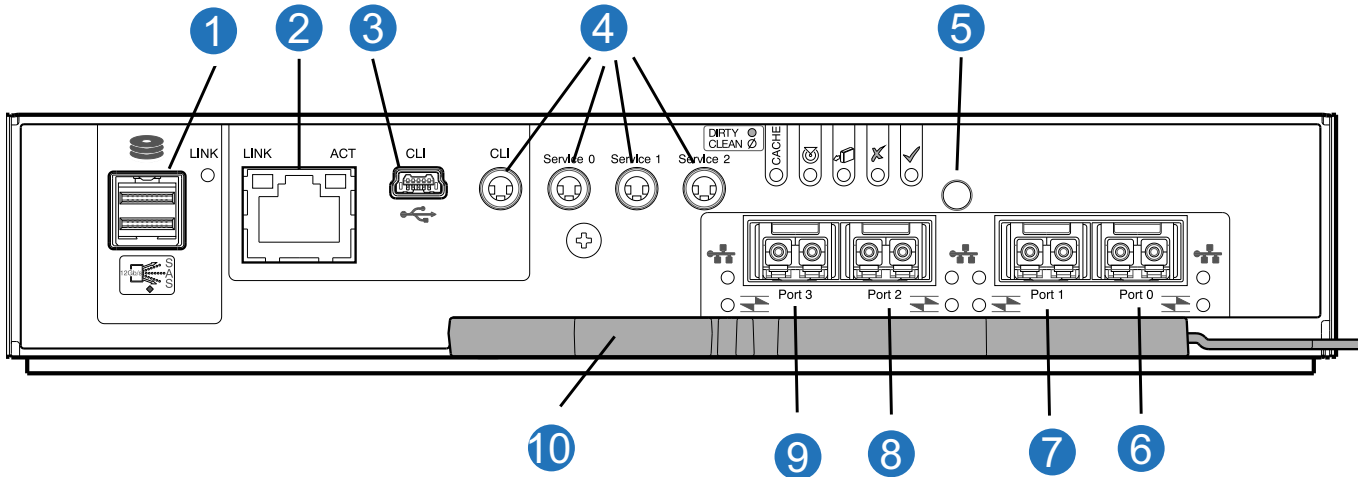

- |   |            |    |                             |
|---|------------|----|-----------------------------|
| 1 | SAS Port   | 2  | Ethernet Port               |
| 3 | USB Port   | 4  | Serial Ports (service only) |
| 5 | Reset      | 6  | CNC Port 0                  |
| 7 | CNC Port 1 | 8  | CNC Port 2                  |
| 9 | CNC Port 3 | 10 | Lock/Release Handle         |

## 2U24-Drive Expansion Chassis Front View

Integers on the drives indicate drive slot numbering sequence (0-23). [Figure 28](#) provides a front view of the 2U24-drive chassis.

**Figure 28** 2U24-Drive Chassis Front View

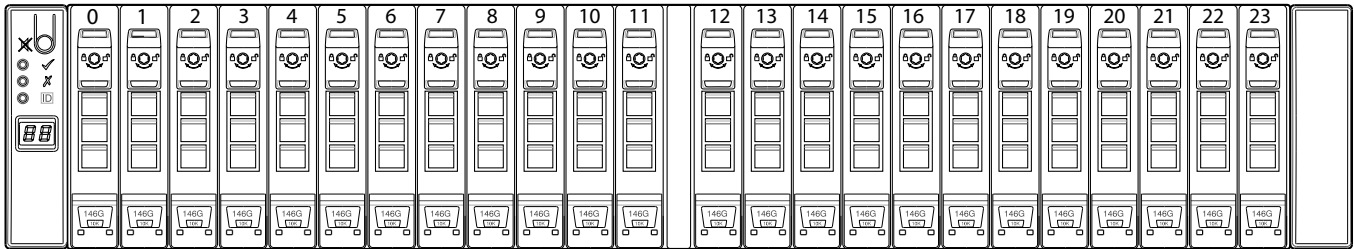

## 2U24-Drive Expansion Chassis Rear View

The top middle slot, [Figure 29](#), is the Expansion IOM A location. The lower middle slot is the Expansion IOM B location. Both IOMs are shown in the closed/locked position.

### Expansion Chassis

[Figure 29](#) provides a rear view of the 2U24-drive expansion chassis rear panel. The expansion chassis attaches to the RAID chassis for additional storage.

**Figure 29** 2U24-Drive Expansion Chassis Rear View

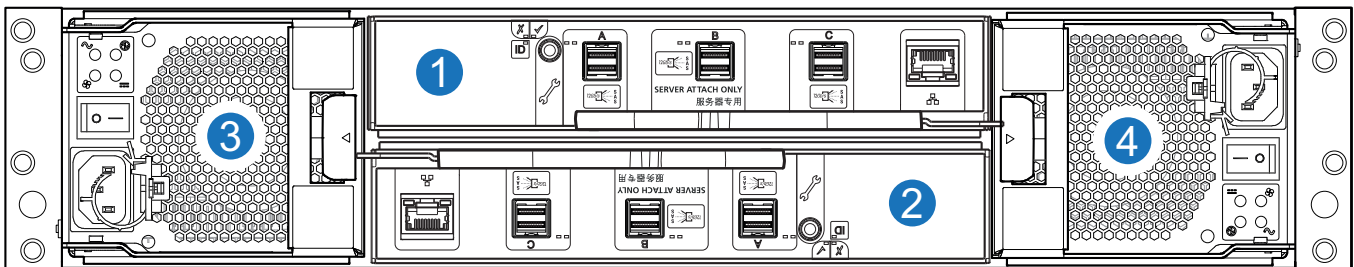

- |   |       |   |       |
|---|-------|---|-------|
| 1 | IOM A | 2 | IOM B |
| 3 | PSU0  | 4 | PSU1  |

## Expansion Chassis IOM

Figure 30 provides a rear view of the expansion chassis IOM used in the 2U24-drive systems. Ports A/B/C ship configured with 12Gb/s HD mini-SAS (SFF-8644) external connectors.

Figure 30 Expansion Chassis IOM

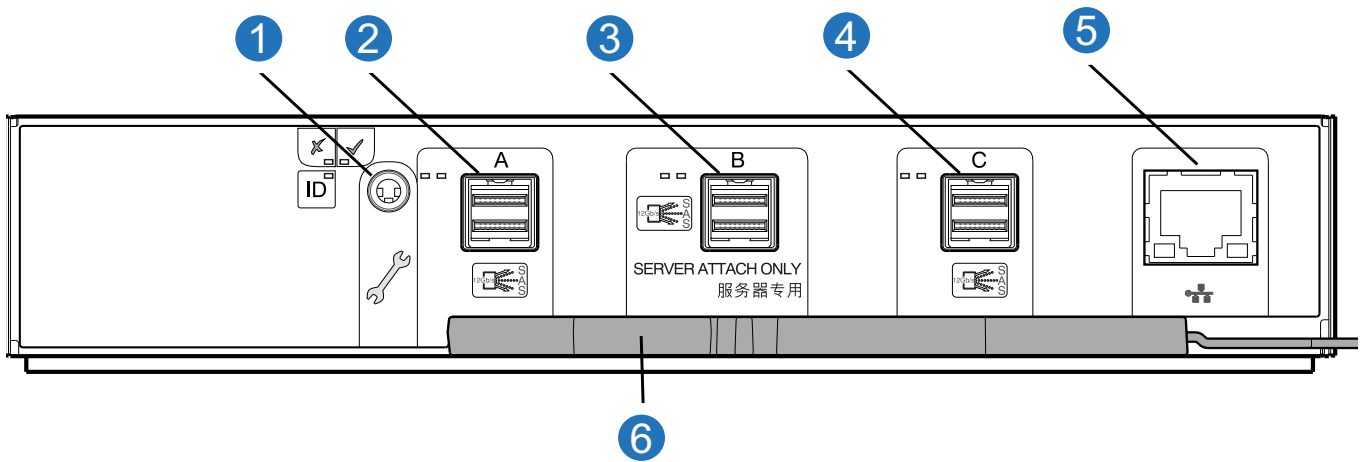

1	SAS Port	2	SAS Port A
3	SAS Port B	4	SAS Port C
5	Ethernet Port	6	Lock/Release Handle

---

**IMPORTANT:** RAID chassis and expansion configurations:

- When the expansion chassis shown above (Figure 29) is used with RAID chassis for adding storage, its middle HD mini-SAS expansion port ("B") is disabled by the firmware.
  - The Ethernet port on the expansion module is not used in RAID chassis and expansion configurations, and is disabled.
-

## Power Supply Unit (PSU)

Figure 31 provides an illustration of the PSU used in the RAID chassis and the expansion chassis. They are identical in the 12-drive and 24-drive chassis. Figure 31 shows an example of a PSU oriented for use in the left PSU Slot 0 of the RAID or expansion chassis.

Figure 31 PSU

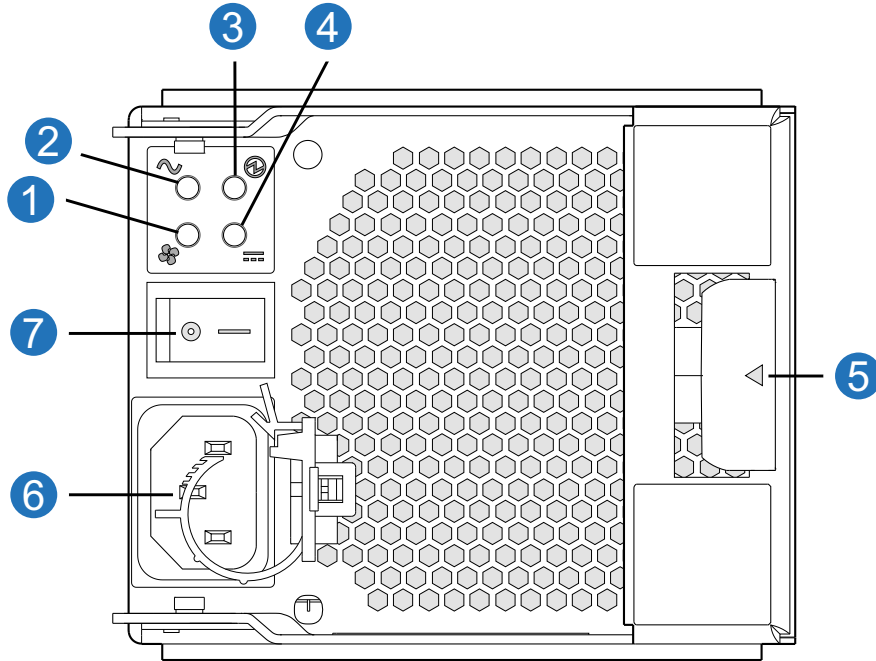

- |   |                     |   |               |
|---|---------------------|---|---------------|
| 1 | Fan Fail LED        | 2 | AC Fail LED   |
| 3 | PSU OK LED          | 4 | DC Fail LED   |
| 5 | Release/Lock Handle | 6 | Power Connect |

---

## QXS-324/424 12G RAID and Expansion Physical Requirements

The floor space at the installation site must be strong enough to support the combined weight of the rack, RAID chassis, expansion chassis, and any additional equipment. The site also requires sufficient space for installation, operation, and servicing of the chassis, together with sufficient ventilation to allow a free flow of air to all chassis.

### Composition

The RAID chassis and expansion chassis is comprised of sheet steel that is bonded together using rivets, welding, and other forced contact methods. The metal surfaces are free from non-conductive coatings and paint.

## Chassis Designators

The RAID and expansion chassis designators are as follows:

- 2U24 chassis (SFF):
  - “2U24” denotes the 2.5” 24-drive chassis (with controller or expansion modules)
  - The 2U24 chassis ships with drives installed.
  - The chassis uses:
    - 2.5” SAS
    - 2.5” SATA
- Two controller modules or two expansion modules per chassis
- Two power supplies per chassis

---

## QXS-324/424 12G RAID and Expansion Chassis Dimensions

Table 13 provides the 2U24 RAID and expansion chassis dimensions.

**Table 13** 2U24 RAID and Expansion Chassis Dimensions

Specification	Metric Unit	Imperial Unit
Overall chassis height (2U)	87.9 mm	3.46 in
Width across mounting flange (located on front of chassis)	483 mm	19.01 in
Width across body of chassis	443 mm	17.44 in
Depth from face of mounting flange to back of chassis body	576.8 mm	22.71 in
Depth from face of mounting flange to rearmost chassis extremity	602.9 mm	23.74 in
Depth from face of Ops panel to rearmost chassis extremity	629.6 mm	24.79 in

**Note:** The 2U24 chassis uses 2.5" SFF drives.

---

## QXS-324/424 12G RAID and Expansion Rackmount Chassis Weights

Table 14 provides the chassis weights for the 2U24 RAID and expansion chassis.

**Table 14** 2U24 RAID and Expansion Chassis Weights

CRU/Component	2U24 (kg/lb)
Storage chassis (empty)	4.8/10.56
Disk drive carrier	0.3/0.66
Dummy disk drive carrier (air management sled)	0.05/0.11
2U Power Supply Unit (PSU)	3.5/7.7
Controller (module in RAID chassis)	2.6/5.8

**Table 14** (continued) 2U24 RAID and Expansion Chassis Weights

CRU/Component	2U24 (kg/lb)
Expansion IOM (module in expansion chassis)	1.5/3.3
RAID chassis (fully populated with modules: maximum weight)	30/66
Expansion chassis (fully populated with modules: maximum weight)	25/55

**Note 1:** Weights shown are nominal, and subject to variances.

**Note 2:** 2U rail kits add between 2.8 kg (6.2 lb) and 3.4 kg (7.4 lb) to the aggregate chassis weight.

**Note 3:** Weights may vary due to different power supplies, controllers/expansion IOMs, and differing calibrations between scales.

**Note 4:** Weights may vary due to actual number and type of drives (SAS, SATA, or SSD) and air management modules installed.





## Chapter 4

# QXS-484 12G System Specifications

---

This chapter provides the following information:

- QXS-484 12G: 5U84-Drive RAID and Expansion Chassis
- QXS-484 12G RAID and Expansion Physical Requirements
- QXS-484 12G RAID and Expansion Chassis Dimensions
- QXS-484 12G RAID and Expansion Rackmount Chassis Weights

---

## QXS-484 12G: 5U84-Drive RAID and Expansion Chassis

This section provides 5U84-drive RAID and expansion chassis system component/CRU information. Chassis is shipped without drives installed. Drives are shipped in two separate boxes (42 drives in each box).

### 5U84-Drive Chassis

Figure 32 provides a front view of the 5U84-drive chassis.

Figure 32 5U84-Drive Chassis

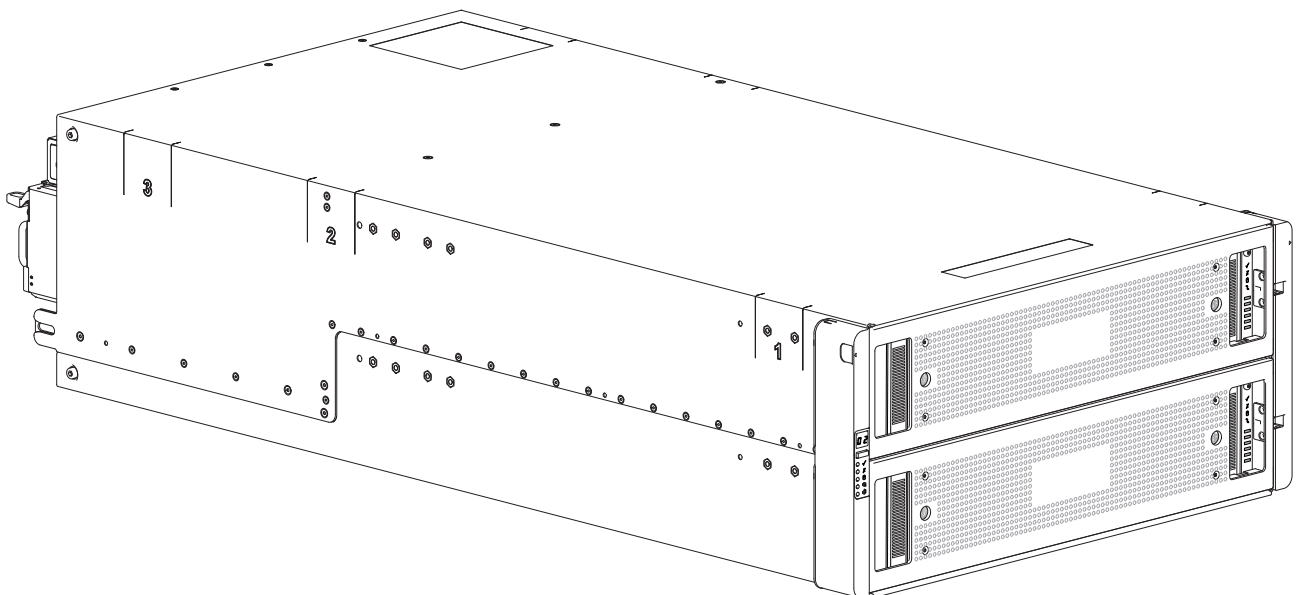

The 5U84 chassis can be configured as a RAID chassis or an expansion chassis.

Table 15 provides the QXS-484 12G chassis components/CRUs.

**Table 15** Chassis Components/CRUs

Product	Configuration	Drives	PSUs <sup>1</sup>	I/O Modules	Fan Modules <sup>3</sup>	Bezel <sup>4</sup>
5U84 RAID Chassis	12Gb/s direct dock drives	84 LFF or SFF <ul style="list-style-type: none"><li>• 2.5" and 3.5" SAS</li><li>• 3.5" SATA</li></ul>	2	2 Controllers	5 <sup>3</sup>	2
5U84 Expansion Chassis	12Gb/s direct dock drives	84 LFF or SFF <ul style="list-style-type: none"><li>• 2.5" and 3.5" SAS</li><li>• 3.5" SATA</li></ul>	2	2 Expansion IOMs <sup>2</sup>	5 <sup>3</sup>	2

PSUs<sup>1</sup>: Redundant PSUs must be compatible modules of the same type (both AC). Power cords are shipped with all chassis.

IOMs<sup>2</sup>: Supported expansion IOMs are used in expansion chassis for adding storage.

Fan Modules<sup>3</sup>: The fan modules are separate CRUs and not integrated within the PSUs. Fan modules are only used within the 5U84 drive chassis.

Bezel<sup>4</sup>: Bezels ship as follows:

- The 2U12 chassis has a bezel shipped in a separate box and must be installed on site.
- The 2U24 chassis has a bezel shipped in a separate box and must be installed on site.
- The 5U84 chassis ships with the bezels (2 each) installed on the upper drawer (Drawer 0) and the lower drawer (Drawer 1).

Note: Ethernet cables are shipped with all RAID chassis.

**CAUTION:** The RAID chassis supports dual-controller configuration only.

- If a partner controller fails, the storage system will fail over and run on a single controller module until the redundancy is restored.

- A RAID controller or expansion IOM must be installed in IOM slot to ensure sufficient air flow through the chassis during operation.

## 5U84-Drive RAID and Expansion Chassis Dimensions

**CAUTION:** Bending an FC cable excessively can cause damage to the cable. Do not bend an FC cable no more than:

- 10 times the cable's outside diameter (no load)
- 15 times the cable's outside diameter (loaded)

Table 16 identifies dimensions of the QXS-484 12G RAID and expansion chassis.

**Table 16** Chassis Dimensions

Specification	Metric Unit	Imperial Unit
Overall chassis height (5U)	222.3 mm	8.75 in
Width across mounting flange (located on front of chassis)	483 mm	19.01 in
Width across body of chassis	444.5 mm	17.50 in
Depth from face of mounting flange to back of chassis body	892.2 mm	35.12 in
Depth from face of mounting flange to rearmost chassis extremity	974.7 mm	38.31 in
Depth from face of Ops panel to rearmost chassis extremity	981 mm	38.62 in

**Note:** When installing a QXS-484 12G RAID or expansion chassis with FC cables, allow approximately two (2) inches at the rear of the chassis to ensure the FC cables can bend within the cabinet and not to exceed the FC cable bend radius. The extra two (2) inches allows the cabinet doors to be closed and no damage to the FC cables.

**Note:** The 5U84 uses 3.5" LFF disks in the DDIC carrier. It can also use 2.5" SFF disks with 3.5" adapter in the DDIC.

## 5U84-Drive RAID and Expansion Chassis Weight

Table 17 identifies the weight of the QXS-484 12G RAID and expansion chassis.

**Table 17** Chassis Weights

CRU/Component	5U84 (kg/lb)
Storage chassis (empty)	64/141
Disk drive carrier	0.8/1.8
Dummy disk drive carrier (air management sled)	-
2U Power Supply Unit (PSU)	-
5U Power Supply Unit (PSU)	2.7/6.0
5U Fan	1.4/3.0
Controller (module in RAID chassis)	2.6/5.8
Expansion IOM (module in expansion chassis)	1.5/3.3
RAID chassis (fully populated with modules: maximum weight)	135/298
Expansion chassis (fully populated with modules: maximum weight)	130/287

**Note 1:** Weights shown are nominal, and subject to variances.

**Note 2:** 5U rail kits add significantly more weight.

**Note 3:** Weights may vary due to different power supplies, controllers/expansion IOMs, and differing calibrations between scales.

**Note 4:** Weights may vary due to actual number and type of drives (SAS or SSD) and air management modules installed.

## Bezel

The 5U84 chassis ships with the bezels (2 each) installed on the upper drawer (Drawer 0) and the lower drawer (Drawer 1). The bezel, comprised of a vented cover attached to an electro-magnetic interference (EMI) shield, is pre-installed at the factory.

Instructions for replacing (removing/installing) the bezel are provided in the QXS 12G Hardware Installation and Maintenance Guide.

---

**CAUTION:** The bezel should be properly installed while the chassis is in operation to ensure adequate EMI protection for the drives.

---

## 5U Chassis Front View

Figure 33 provides an illustration of the front of the 5U84 RAID or expansion chassis (with bezels installed). Drawer 0 is at the top of the chassis. Drawer 1 is at the bottom of the chassis.

Figure 33 Front of 5U84 RAID or Expansion Chassis

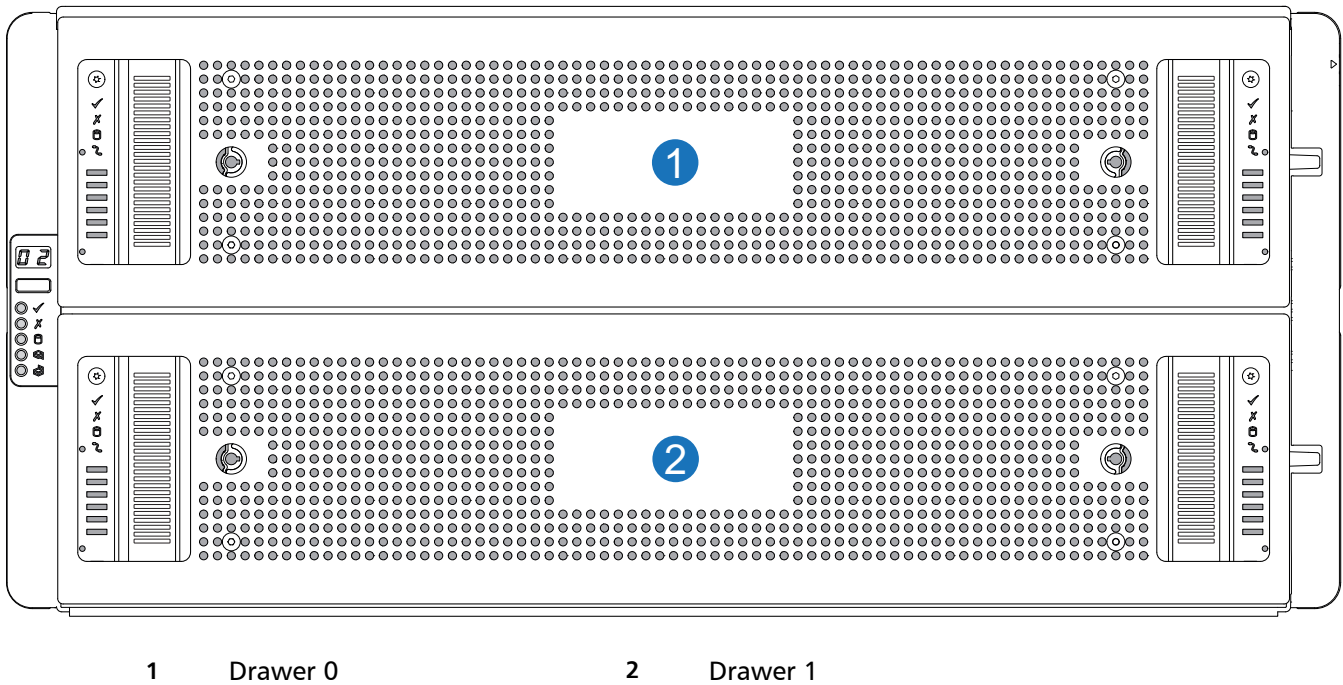

## 5U Chassis Drive Slots View

Figure 34 provides an illustration of the 5U84 RAID or expansion chassis (drive slots view) with the drawer open. There are a total of 84 drive slots in the two drawers.

- Drawer 0 has drive slots 0-41 (42 drives can be installed)
- Drawer 1 has drive slots 42-83 (42 drives can be installed)

**IMPORTANT:** Drawer sideplanes—also known as side cards—can be hot-swapped as field-replaceable units (FRUs).

However, these FRUs require a special tool, and replacement should be performed by qualified service personnel only.

Contact your service provider for more information.

**NOTE:** Figure 34 displays the front of the drawer on the left side of the illustration. The back of the drawer is on the right side of the illustration.

**Figure 34** 5U84 RAID or Expansion Chassis Drive Slots

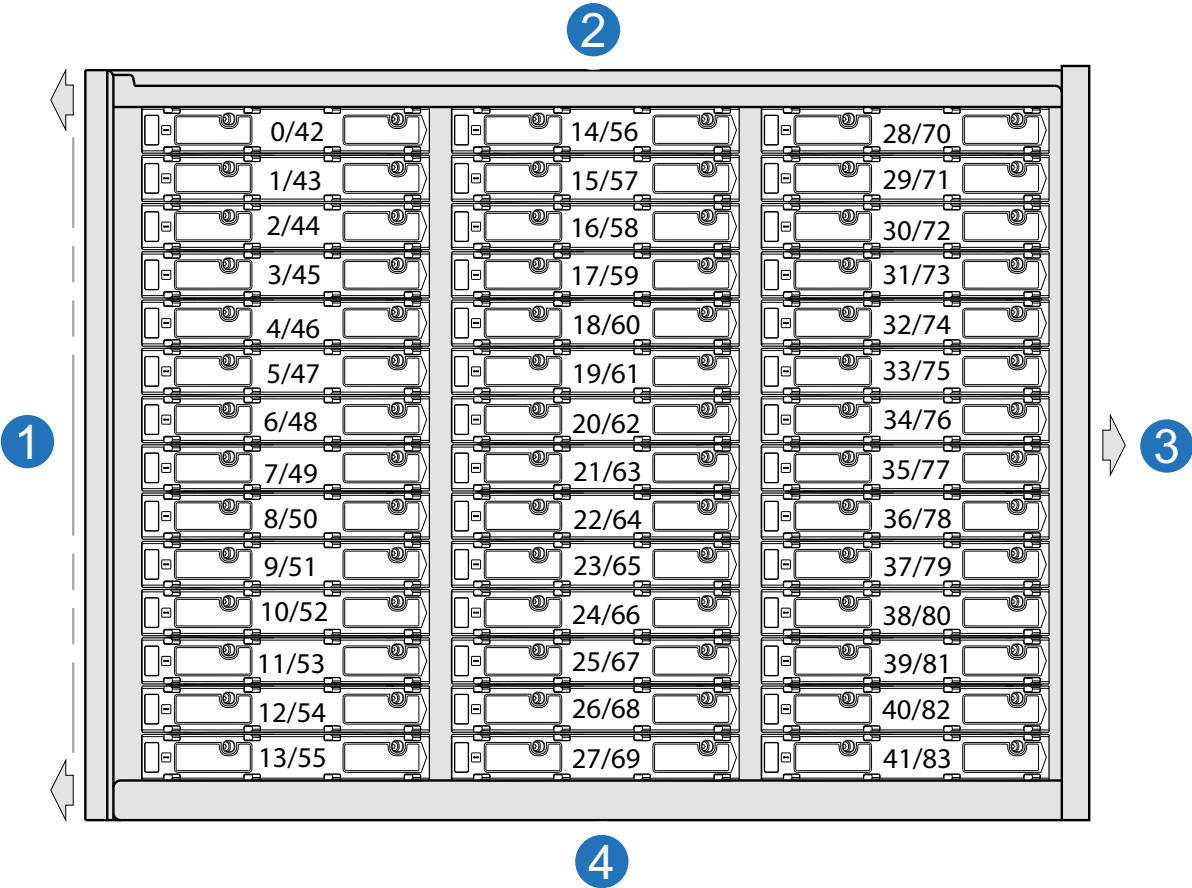

- 1 Drawer 0/1 Front
- 2 Drawer 0/1 Left Side
- 3 Drawer 0/1 Rear (slides into chassis)
- 4 Drawer 0/1 Right Side

## 5U84 RAID Chassis (Rear View/Two CNC Controllers)

Figure 35 provides an illustration of the 5U84 RAID chassis rear view with two CNC controllers (FC/iSCSI, 4-ports) installed.

---

**NOTE:** The 5U84 RAID chassis supports attachment of expansion chassis for adding storage.

---

Refer to Figure 35 for all the 5U84 Raid chassis CRUs with CNC controllers.

**Figure 35** 5U84 RAID Chassis Rear View (CNC Controllers)

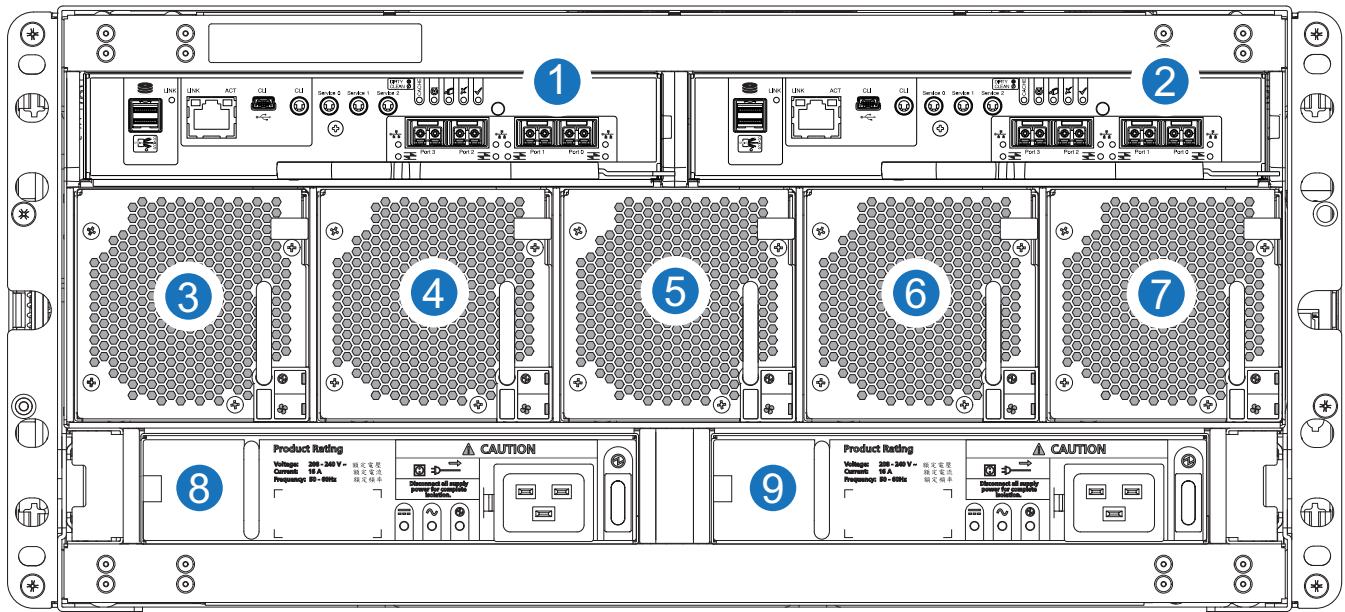

1	Controller A	2	Controller B	3	Fan 0
4	Fan 1	5	Fan 2	6	Fan 3
7	Fan 4	8	PSU 0	9	PSU 1

## CNC FC/iSCSI Controller

Callout 1, [Figure 35](#), is the Controller A location. Callout 2 [Figure 35](#), is the Controller B location. Both controllers are shown in the closed/locked position.

[Figure 36](#) provides a rear view of the CNC FC/iSCSI controller used in the 5U84-drive systems. You can configure the CNC host interface ports (Ports 0, 1, 2 and 3) with 8/16Gb/s FC SFPs; 10GbE iSCSI SFPs; or 1Gb/s RJ-45 SFPs.

**Figure 36** CNC FC/iSCSI Controller

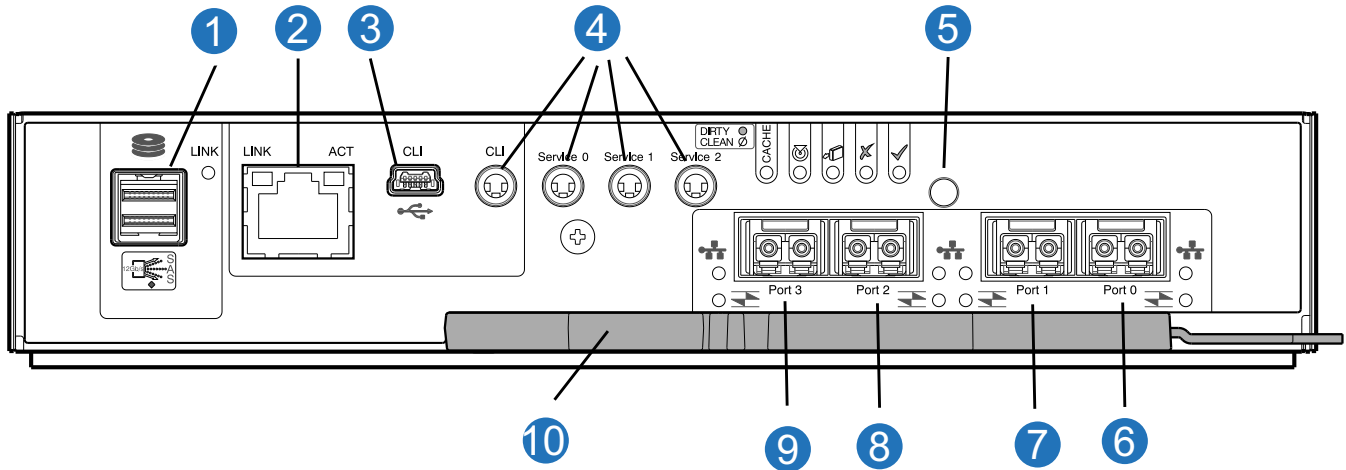

1	SAS Port	2	Ethernet Port
3	USB Port	4	Serial Ports (service only)
5	Reset	6	CNC Port 0
7	CNC Port 1	8	CNC Port 2
9	CNC Port 3	10	Lock/Release Handle

## 5U84 Expansion Chassis (Rear View)

[Figure 37](#) provides an illustration of the 5U84 expansion chassis rear view with two expansion IOMs (2-SAS ports used) installed.

Refer to [Figure 37](#) for all the 5U84 expansion chassis CRUs with expansion IOMs.

**NOTE:** The 5U84 expansion chassis uses the same expansion IOMs as the 2U12 and 2U24 expansion chassis.

**Figure 37** 5U84 Expansion Chassis Rear View (SAS)

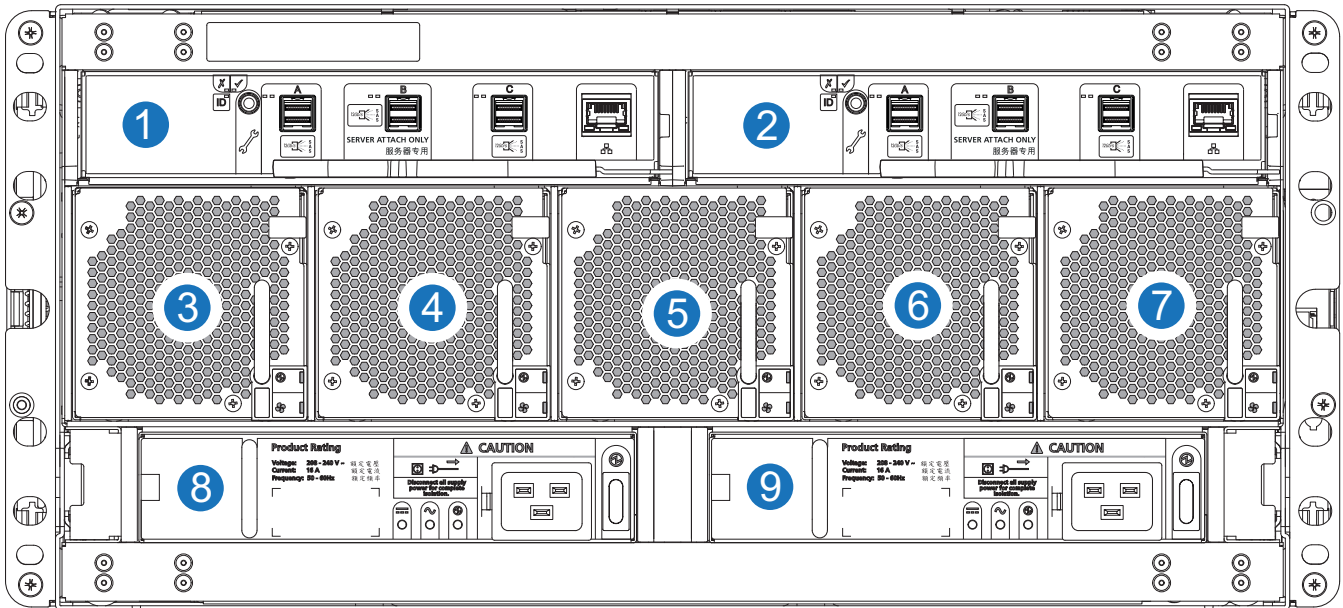

1	IOM A	2	IOM B	3	Fan 0
4	Fan 1	5	Fan 2	6	Fan 3
7	Fan 4	8	PSU 0	9	PSU 1

### Expansion Chassis IOM

Figure 38 provides a rear view of the expansion chassis IOM used in the 5U84-drive systems. Ports A/B/C ship configured with 12Gb/s HD mini-SAS (SFF-8644) external connectors.

**Figure 38** Expansion Chassis IOM

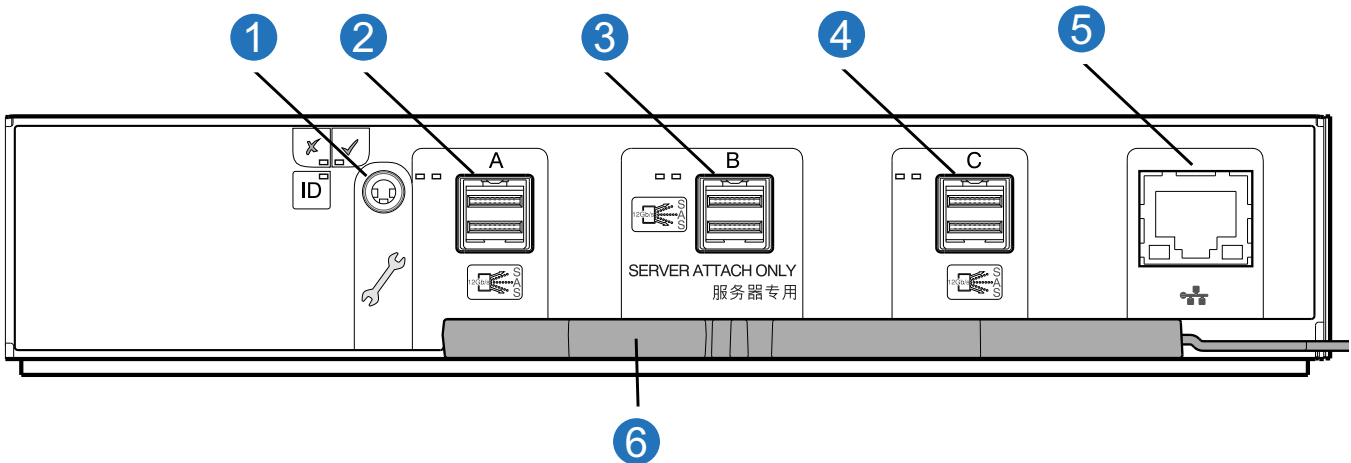

1	SAS Port	2	SAS Port A
3	SAS Port B	4	SAS Port C
5	Ethernet Port	6	Lock/Release Handle

**IMPORTANT:** RAID chassis and expansion configurations:

- When the expansion chassis shown above (Figure 38) is used with RAID chassis for adding storage, its middle HD mini-SAS expansion port ("B") is disabled by the firmware.
- The Ethernet port on the expansion module is not used in RAID chassis and expansion configurations, and is disabled.

## Power Supply Unit (PSU)

Figure 39 provides an illustration of the PSU used in the 5U84 RAID chassis and the expansion chassis (oriented for use in the left PSU Slot 0 and right PSU Slot 1).

Figure 39 5U84 Chassis PSU

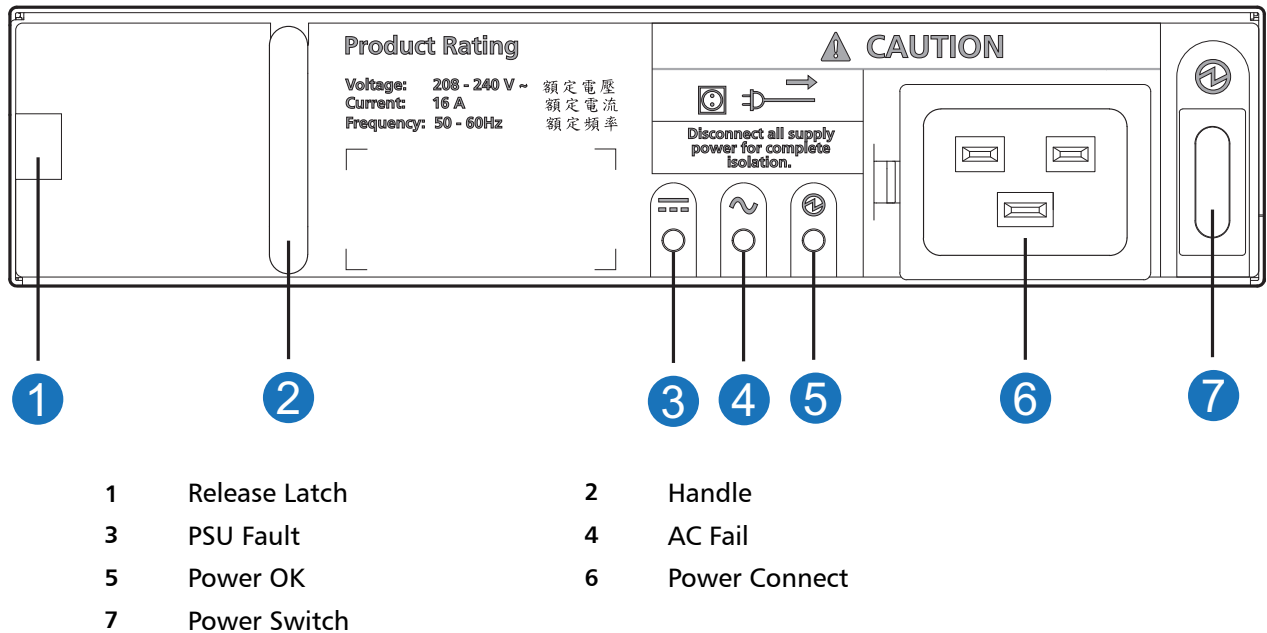

## Fans

Figure 40 provides an illustration of the fan used in the 5U84 RAID chassis and the expansion chassis. The 5U84 RAID or expansion chassis uses five fans for sufficient cooling and air flow for the

chassis. [Figure 37](#) on page 40 shows an example of a fan oriented for use in the Fan 0, Fan 1, Fan 2, Fan 3, and Fan 4 slots of the RAID or expansion chassis.

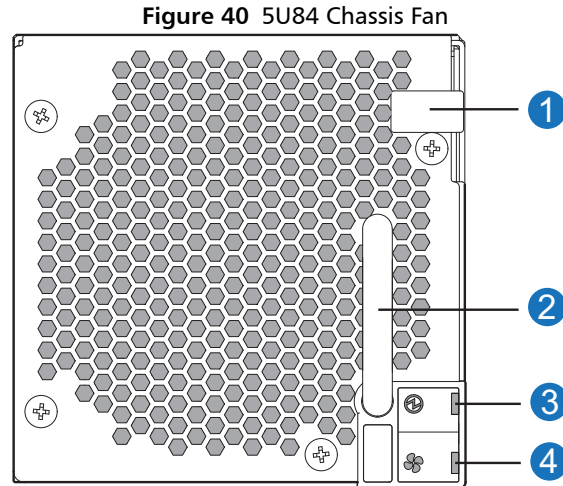

- |   |               |   |           |
|---|---------------|---|-----------|
| 1 | Release Latch | 2 | Handle    |
| 3 | Fan OK        | 4 | Fan Fault |

---

## QXS-484 12G RAID and Expansion Physical Requirements

The floor space at the installation site must be strong enough to support the combined weight of the rack, RAID chassis, expansion chassis, and any additional equipment. The site also requires sufficient space for installation, operation, and servicing of the chassis, together with sufficient ventilation to allow a free flow of air to all chassis.

### Composition

The RAID chassis and expansion chassis is comprised of sheet steel that is bonded together using rivets, welding, and other forced contact methods. The metal surfaces are free from non-conductive coatings and paint.

### Chassis Designators

The RAID and expansion chassis designators are as follows:

- 5U84 chassis (SFF):
  - “5U84” denotes the following (with controller or expansion modules)
    - 5U is the height of the chassis (8.75 inches)
    - 84 denotes the total number of drives that can be installed within the two drawers
  - The 5U84 chassis ships without drives installed.
  - Drives that can be installed within the chassis are:
    - 2.5” (with an adapter) and 3.5” SAS
    - 3.5” SATA
  - Two controller modules or two expansion modules per chassis
  - Two power supplies per chassis
  - Five fans per chassis

# QXS-484 12G RAID and Expansion Chassis Dimensions

Table 18 provides the 5U84 RAID and expansion chassis dimensions.

Table 18 QXS 5U Chassis Dimensions

Specification	Metric Unit	Imperial Unit
Overall chassis height (5U)	222.3 mm	8.75 in
Width across mounting flange (located on front of chassis)	483 mm	19.01 in
Width across body of chassis	444.5 mm	17.50 in
Depth from face of mounting flange to back of chassis body	892.2 mm	35.12 in
Depth from face of mounting flange to rearmost chassis extremity	974.7 mm	38.31 in
Depth from face of Ops panel to rearmost chassis extremity	981 mm	38.62 in

**Note:** The 5U84 uses 3.5" LFF disks in the DDIC carrier. It can also use 2.5" SFF disks with 3.5" adapter in the DDIC.

# QXS-484 12G RAID and Expansion Rackmount Chassis Weights

Table 19 provides the chassis weights for the 5U84 RAID and expansion chassis.

Table 19 5U84 RAID and Expansion Chassis Weights

CRU/Component	5U84 (kg/lb)
Storage chassis (empty)	64/141
Disk drive carrier	0.8/1.8
5U Power Supply Unit (PSU)	2.7/6.0
5U Fan	1.4/3.0
Controller (module in RAID chassis)	2.6/5.8
Expansion IOM (module in expansion chassis)	1.5/3.3
RAID chassis (fully populated with modules: maximum weight)	135/298
Expansion chassis (fully populated with modules: maximum weight)	13/287

**Note 1:** Weights shown are nominal, and subject to variances.

**Note 2:** 5U rail kits add significantly more weight.

**Note 3:** Weights may vary due to different power supplies, controllers/expansion IOMs, and differing calibrations between scales.

**Note 4:** Weights may vary due to actual number and type of drives (SAS, SATA, or SSD) installed.





# Environment and Requirements

This chapter provides the following information:

- QXS 2U/5U Environmental Requirements
- QXS 2U/5U PSU Specifications
- International Standards
- Potential for Radio Frequency Interference
- European Regulations
- Safety Compliance
- EMC Compliance
- AC Power Cords
- Recycling of Waste Electrical and Electronic Equipment (WEEE)

## QXS 2U/5U Environmental Requirements

This section contains the following information:

- QXS 2U/5U Ambient Temperature and Humidity Requirements
- QXS 2U/5U Additional Environmental Requirements

### QXS 2U/5U Ambient Temperature and Humidity Requirements

Table 20 provides the 2U/5U ambient temperature and humidity requirements.

**Table 20** QXS 2U/5U Ambient Temperature and Humidity Requirements

Specification	Temperature Range	Relative Humidity	Maximum Wet Bulb
Operating	RAID Chassis: 5°C to 35°C (41°F to 95°F) Expansion Chassis: 5°C to 40°C (41°F to 104°F)	20% to 80% non-condensing	28°C
No-operating (shipping)	-40°C to +70°C (-40°F to +158°F)	5% to 100% non-precipitating	29°C

## QXS 2U/5U Additional Environmental Requirements

Table 21 provides the 2U/5U additional environmental requirements.

**Table 21** QXS 2U/5U Additional Environmental Requirements

Specification	Measurement/Description
Airflow	System must be operated with low pressure rear exhaust installation. Back pressure created by rack doors and obstacles not to exceed 5Pa (0.5 mm H <sub>2</sub> O)
Altitude (operating)	2U chassis: 0 to 3,000 meters (0 to 10,000 feet) Maximum operating temperature is de-rated by 5°C above 2,133 meters (7,000 feet)
	5U chassis: -100 to 3,000 meters (-330 to 10,000 feet) Maximum operating temperature is de-rated by 1°C above 900 meters (3,000 feet)
Altitude (non-operating)	-100 to 12,192 meters (-330 to 40,000 feet)
Shock (operating)	5.0 g, 10 ms, ½ sine pulses, Y-axis
Shock (non-operating)	2U chassis: 30.0 g, 10 ms, ½ sine pulses
	5U chassis: 30.0 g, 10 ms, ½ sine pulses (Z-axis); 20.0 g, 10 ms, ½ sine pulses (X- and Y-axes)
Vibration (operating)	0.21 G <sub>rms</sub> 5 Hz to 500 Hz random
Vibration (non-operating)	1.04 G <sub>rms</sub> 2 Hz to 200 Hz random
Vibration (relocation)	0.3 G <sub>rms</sub> 2 Hz to 200 Hz 0.4 decades per minute
Acoustics	Operating sound power
	2U chassis: £ L <sub>WAd</sub> 6.6 Bels (re 1 pW) @ 23°C
	5U chassis: £ L <sub>WAd</sub> 8.0 Bels (re 1 pW) @ 23°C
Operating and mounting:	19" rack mount (2 EIA units; 5 EIA units)
• Rack rails	To fit 800 mm depth racks compliant with the SSI server rack specification
• Rack characteristics	Back pressure not exceeding 5Pa (~0.5 mm H <sub>2</sub> O)

## QXS 2U/5U PSU Specifications

This section contains the following information:

- [QXS 2U PSU \(580W\) Specifications](#)
- [QXS 5U PSU \(2114W\) Specifications](#)

## QXS 2U PSU (580W) Specifications

Table 22 provides the 2U PSU (580W) specifications.

**Table 22** QXS 2U PSU (580W) Specifications

Specification	Measurement/Description	
Dimensions (size)	84.3 mm high x 104.5 mm wide x 340.8 mm long: <ul style="list-style-type: none"> <li>X-axis length: 104.5 mm (4.11 in)</li> <li>Y-axis length: 84.3 mm (3.32 in)</li> <li>Z-axis length: 340.8 mm (37.03)</li> </ul>	
Maximum output power	580W	
Voltage range	100–200 VAC rated	
Frequency	50-60 Hz	
Voltage range selection	Auto-ranging: 90–264 VAC, 47–63 Hz	
Power factor correction	³ 95% @ nominal input voltage	
Efficiency	115 VAC/60 Hz	230 VAC/50 Hz
	> 80% @ 10% load	> 80% @ 10% load
	> 87% @ 20% load	> 88% @ 20% load
	> 90% @ 50% load	> 92% @ 50% load
	> 87% @ 100% load	> 88% @ 100% load
	> 85% @ surge	> 85% @ surge
Harmonics	Meets EN61000-3-2	
Output	+5 V @ 42A, +12 V @ 38A, +5 V standby voltage @ 2.7A	
Operating temperature	0 to 57°C (32°F to +135°F)	
Hot pluggable	Yes	
Switches and LEDs	AC mains switch and four status indicator LEDs	
Chassis cooling	Dual axial cooling fans with variable fan speed control	

## QXS 5U PSU (2114W) Specifications

Table 23 provides the 5U PSU (2114W) specifications.

**Table 23** QXS 5U PSU (2114W) Specifications

Specification	Measurement/Description
Maximum output power	2214W maximum continuous output power at high line voltage
Voltage	+12 V at 183 A (2,196 W) +5 V standby voltage at 2.7 A
Voltage range	200–240 VAC rated
Frequency	50-60 Hz
Power factor correction	>/= 95% @ 100% load

**Table 23** (continued) QXS 5U PSU (2114W) Specifications

Specification	Measurement/Description
Efficiency	82% @ 10% load 90% @ 20% load 94% @ 50% load 91% @ 100% load
Holdup time	5 ms from ACOKn high to rails out of regulation (see SBB v2 specification)
Mains inlet connector	IEC60320 C20 with cable retention
Weight	3 kg (6.6 lb)
Cooling fans	2 stacked fans: 80x80x38mm

---

## International Standards

The QXS-312, QXS-324, QXS-412, QXS-424, and QXS-484 systems comply with the requirements of the following agencies and standards:

- CE to EN 60950-1
- CB report to IEC 60950-1
- UL & cUL to UL 60950-1 second edition

---

## Potential for Radio Frequency Interference

USA Federal Communications Commission (FCC)

### Notice

This equipment has been tested and found to comply with the limits for a class A digital device, pursuant to Part 15 of the FCC rules. These limits are designed to provide reasonable protection against harmful interference when the equipment is operated in a commercial environment. This equipment generates, uses, and can radiate radio frequency energy, and if not installed and used in accordance with the instruction manual, may cause harmful interference to radio communications. Operation of this equipment in a residential area is likely to cause harmful interference, in which case the user will be required to correct the interference at his or her expense.

Properly shielded and grounded cables and connectors must be used in order to meet FCC emission limits. The supplier is not responsible for any radio or television interference caused by using other than recommended cables and connectors or by unauthorized changes or modifications to this equipment. Unauthorized changes or modifications could void the user's authority to operate the equipment.

This device complies with Part 15 of the FCC Rules. Operation is subject to the following two conditions: (1) this device may not cause harmful interference, and (2) this device must accept any interference received, including interference that may cause undesired operation.

---

## European Regulations

This equipment complies with European Regulations EN 55022 Class A: Limits and Methods of Measurement of Radio Disturbance Characteristics of Information Technology Equipment and EN50082-1: Generic Immunity.

---

## Safety Compliance

Table 24 provides safety compliance specifications.

**Table 24** Safety Compliance Specifications

Item	Compliance
System product type approval	UL/cUL/CE
Safety Compliance	UL 60950-1 second edition
	IEC 60950-1
	EN 60950-1

---

## EMC Compliance

Table 25 provides EMC compliance specifications.

**Table 25** EMC Compliance Specifications

Item	Compliance
Conducted emissions limit levels	CFR47 Part 15B Class A
	EN55022 Class A
	CISPR Class A
Radiated emissions limit levels	CFR47 Part 15B Class A
	EN55022 Class A
	CISPR Class A
Harmonics and flicker	EN61000-3-2/3
Immunity limit levels	EN55024

# AC Power Cords

Table 26 provides the AC power cord specifications.

**Table 26** AC Power Cord Specifications

1	<b>United States of America–Must be NRTL Listed (National Recognized Test Laboratory – e.g., UL):</b>		
	<b>Chassis form factor</b>	<b>2U12/2U24</b>	<b>5U84</b>
	Cord type	SV or SVT, 18 AWG minimum, 3 conductor, 2.0M max length	SJT or SVT, 12 AWG minimum, 3 conductor
	Plug (AC source)	NEMA 5–15P grounding-type attachment plug rated 120V 10A	IEC 320, C-20, 250V, 20A
		or IEC 320, C-14, 250V, 10A	or A suitable plug rated 250V, 20A
Socket	IEC 320, C-13, 250V, 10A	IEC 320, C-19, 250V, 20A	
2	<b>Europe and others–General requirements:</b>		
	<b>Chassis form factor</b>	<b>2U12/2U24</b>	<b>5U84</b>
	Cord type	Harmonized, H05-WF-3G1.0	Harmonized, H05-WF-3G2.5
	Plug (AC source)		IEC 320, C-20, 250V, 16A
			or A suitable plug rated 250V, 16A
Socket	IEC 320, C-13, 250V, 10A	IEC 320, C-19, 250V, 16A	

**IMPORTANT:** The plug and the complete power cable assembly must meet the standards appropriate to the country, and must have safety approvals acceptable in that country.

## Recycling of Waste Electrical and Electronic Equipment (WEEE)

At the end of the product’s life, all scrap/waste electrical and electronic equipment should be recycled in accordance with national regulations applicable to the handling of hazardous/toxic electrical and electronic waste materials.

Please contact your supplier for a copy of the Recycling Procedures applicable to your country.

**IMPORTANT:** Observe all applicable safety precautions detailed in the preceding chapters (weight restrictions, handling batteries and lasers, etc.) when dismantling and disposing of this equipment.