

Quantum[®]

Technical Reference Manual

Quantum LTO-8 HH SAS User's Guide



Quantum LTO-8 HH SAS User's Guide, 6-68132-03 Rev A, December 2017, Product of USA.

Quantum Corporation provides this publication "as is" without warranty of any kind, either express or implied, including but not limited to the implied warranties of merchantability or fitness for a particular purpose. Quantum Corporation may revise this publication from time to time without notice.

COPYRIGHT STATEMENT

© 2017 Quantum Corporation. All rights reserved.

Your right to copy this manual is limited by copyright law. Making copies or adaptations without prior written authorization of Quantum Corporation is prohibited by law and constitutes a punishable violation of the law.

TRADEMARK STATEMENT

Quantum, the Quantum logo, DLT, DLTape, the DLTape logo, SuperLoader, Scalar, StorNext, and DXi are registered trademarks of Quantum Corporation, registered in the U.S. and other countries.

Preserving the World's Most Important Data. Yours., Backup. RecoQuantum LTO-8 HH SAS User's Guide. Archive. It's What We Do., the DLT logo, DLTSage, Dynamic Powerdown, FastSense, FlexLink, GoVault, MediaShield, Optyon, Pocket-sized. Well-armored, SDLT, SiteCare, SmartVerify, StorageCare, Super DLTape, and Vision are trademarks of Quantum.

LTO and Ultrium are trademarks of HP, IBM, and Quantum in the U.S. and other countries. All other trademarks are the property of their respective companies.

Specifications are subject to change without notice.

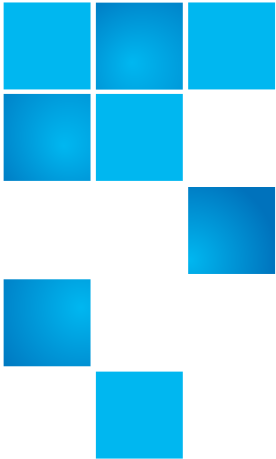

Contents

Chapter 1	Preface	1
	Safety notices	2
	Danger notice	2
	Caution notice	2
	Performing the Safety Inspection Procedure	3
	Tape drive AC grounding inspection	4
	Class I Laser Product	5
	Rack Safety	5
	Power Cords	8
	Product Recycling and Disposal	8
	Battery Return Policy	9
	End of Life (EOL) Plan	10
Chapter 2	Introduction	11
	Drive Features	12
	Front Panel of the Drive	13
	Rear Panel of the Drive	14
	Drive Performance	14

Cartridge Compatibility	15
Speed Matching	16
Channel Calibration	17
Data cartridge capacity scaling	17
Encryption	17
Inhibiting Firmware Down-Leveling	18
SAS Interface	18
Physical Characteristics	18
Supported Operating Systems	19
Supported Device Drivers	19
Ethernet Port	19
IBM Spectrum Archive	20
Specifications	20
Physical specifications	20
Power specifications	21
Other specifications	21
Environmental specifications	21

Chapter 3

Installation	23
Avoiding Drive Damage	24
Unpack the Drive	24
Verify the Shipment	25
Inspect the Power Cord and Outlet	25
Position the Tape Drive	26
Install the SAS Host Adapter Card (if required)	26
Connect the SAS Interface Cable	26
Connect Power	28
Run Drive Diagnostics	29
Install Device Drivers	29
Configure the Tape Drive to a Server/Host	29

Updating firmware	30
Updating Firmware through the Host Interface	30
Updating the firmware with an FUP tape cartridge	30

Chapter 4	Operations	33
------------------	-------------------	-----------

Operating modes.	33
Power Button	34
Single-character Display (SCD).	34
SCD Dot	35
Status Lights	35
Unload Button.	40
Inserting a Tape Cartridge	41
Removing a Tape Cartridge	43
Mid-tape Recovery.	43
Cleaning the Drive Head	44
Cleaning the Tape Drive.	44
Diagnostic and Maintenance Functions.	45
Entering Maintenance Mode.	48
Exiting Maintenance Mode	48
Function Code 0: Maintenance Mode	49
Function Code 1: Run Drive Diagnostics	49
Function Code 2: Update Drive Firmware from FUP Tape	50
Function Code 3: Create FUP Tape	51
Function Code 4: Force a Drive Dump.	52
Function Code 5: Copy Drive Dump	52
Function Code 6: Run Host Interface Wrap Test	54
Function Code 7: Run RS-422 Wrap Test.	55
Function Code 8: Unmake FUP Tape	56
Function Code 9: Display Error Code Log	57
Function Code A: Clear Error Code Log.	57
Function Code C: Insert Cartridge into Tape Drive	58
Function Code E: Test Cartridge & Media	58
Function Code F: Write Performance Test	59
Function Code H: Test Head	60
Function Code J: Fast Read/Write Test.	61
Function Code L: Load/Unload Test.	63

Function Code P: Post Error Reporting Enabled	64
Function Code U: Post Error Reporting Disabled	64

Chapter 5	Media	67
	Data Cartridge.	69
	Cartridge Compatibility	71
	Capacity Scaling	72
	WORM (Write Once, Read Many) Cartridge.	72
	Worm Media.	72
	Data Security on WORM Media.	73
	WORM Media Errors	73
	Requirements for WORM Capability	73
	Cleaning Cartridge	74
	Cartridge Memory Chip (LTO-CM).	74
	LTO-8 Type M Format	75
	Bar Code Labels.	75
	Write-Protect Switch.	77
	Handling Cartridges.	78
	Provide Training	78
	Ensure Proper Packaging.	78
	Provide Proper Acclimation and Environmental Conditions	79
	Perform a Thorough Inspection	79
	Handle the Cartridge Carefully	80
	Examples of Cartridge Problems	81
	Environmental and Shipping Specifications for Tape Cartridges	81
	Disposing of Tape Cartridges.	82

Chapter 6	Troubleshooting	85
	Procedure 1: Determining Firmware Level and Capturing Drive Dump	85
	Procedure 2: Inspecting a Cartridge for Damage.	86
	Procedure 3: Checking SAS Host Connections	87
	Resolving Problems Reported by the Server.	88
	Fixing SAS Bus Errors	88
	Resolving Media-Related Problems	88

Pre-Call Checklist 89

Appendix A Error Codes and Messages 91

Appendix B Tape Alert Flags 101



Chapter 1

Preface

This guide describes how to install and use the Quantum LTO-8 Tape Drive in the following chapters:

[Chapter 2, Introduction](#) describes the product, discusses supported servers, operating systems, and device drivers, and lists hardware specifications.

[Chapter 3, Installation](#) gives unpacking, set up, and configuration information.

[Chapter 4, Operations](#) describes the Power Button, Unload Button, and Status lights and explains the function of the Single-character Display.

It gives instruction on inserting and removing a tape cartridge, describes methods of updating drive firmware, and explains how to clean the tape drive. It also lists diagnostic and maintenance functions.

[Chapter 5, Media](#) describes the types of tape cartridges to use and defines the conditions for storing and shipping them. It also describes how to handle the cartridges, how to set a cartridge's write-protect switch, and how to order additional cartridges.

[Chapter 6, Troubleshooting](#) gives tips for solving problems with the drive.

[Appendix A, Error Codes and Messages](#) describes the error and informational codes that appear on the single-character display.

[Appendix B, Tape Alert Flags](#) describes where to find information on TapeAlert messages that are supported and that may aid during problem determination.

Safety notices

Observe the safety notices when using this product. These safety notices contain danger and caution notices. These notices are sometimes accompanied by symbols that represent the severity of the safety condition.

The sections that follow define each type of safety notice and give examples.

Danger notice

A danger notice calls attention to a situation that is potentially lethal or extremely hazardous to people. A lightning bolt symbol always accompanies a danger notice to represent a dangerous electrical condition. A sample danger notice follows:

WARNING: An electrical outlet that is not correctly wired could place hazardous voltage on metal parts of the system or the devices that attach to the system. It is the responsibility of the customer to ensure that the outlet is correctly wired and grounded to prevent an electrical shock.

Caution notice

A caution notice calls attention to a situation that is potentially hazardous to people because of some existing condition, or to a potentially dangerous situation that might develop because of some unsafe practice. A caution notice can be accompanied by one of several symbols:

If the symbol is... It means...

A generally hazardous condition not represented by other safety symbols.

This product contains a Class II laser. Do not stare into the beam. Laser symbols are always accompanied by the classification of the laser as defined by the U. S. Department of Health and Human Services (for example, Class I, Class II, and so forth).

A hazardous condition due to mechanical movement in or around the product.

This part or unit is heavy but has a weight smaller than 18 kg (39.7 lb). Use care when lifting, removing, or installing this part or unit.

Sample caution notices follow:

Caution: The battery is a lithium ion battery. To avoid possible explosion, do not burn. Exchange only with the Quantum-approved part. Recycle or discard the battery as instructed by local regulations.

Caution: The system contains circuit cards, assemblies, or both that contain lead solder. To avoid the release of lead (Pb) into the environment, do not burn. Discard the circuit card as instructed by local regulations.

Performing the Safety Inspection Procedure

Before you service the unit, perform the following safety inspection procedure:

- 1 Stop all activity on the host bus.
- 2 Turn off the power to the tape drive.
- 3 Disconnect the host interface cable.
- 4 Unplug the tape drive's power cord from the electrical outlet.
- 5 Check the tape drive's power cord for damage, such as a pinched, cut, or frayed cord.
- 6 Check the tape drive's host interface cable for damage.

- 7 Check the cover of the tape drive for sharp edges, damage, or alterations that expose its internal parts.
- 8 Check the cover of the tape drive for proper fit. It should be in place and secure.
- 9 Check the product label on the tape drive to make sure that it matches the voltage at your outlet.

Tape drive AC grounding inspection

- 1 Power off the drive.
- 2 Disconnect all cables.
- 3 See [Figure 1](#) which is provided for reference only. Disconnect the power cord from its source.
- 4 Inspect the power cable for visible cracks, wear, or damage.

Figure 1 AC grounding diagram (50 Hz and 60 Hz)

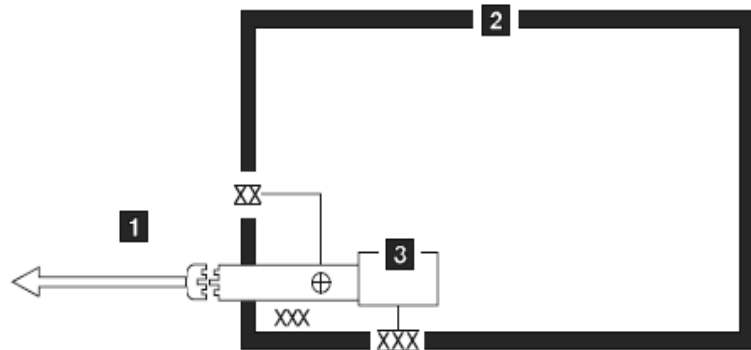

Legend:

- XX External tooth lock washer
- XX Green/yellow ground wire terminated to chassis or ground
- ⊕ Green/yellow ground wire terminated with slip-on spade terminal
- XXX Redundant ground path to frame
- XXX External tooth lock washer

at1400040

Class I Laser Product

The product may contain a laser assembly that complies with the performance standards set by the U.S. Food and Drug Administration for a Class I laser product. Class I laser products do not emit hazardous laser radiation. The product has the necessary protective housing and scanning safeguards to ensure that laser radiation is inaccessible during operation or is within Class I limits. External safety agencies have reviewed the product and have obtained approvals to the latest standards as they apply.

Rack Safety

The following general safety information should be used for all rack mounted devices.

DANGER

- Always lower the leveling pads on the rack cabinet.
- Always install stabilizer brackets on the rack cabinet.
- To avoid hazardous conditions due to uneven mechanical loading, always install the heaviest devices in the bottom of the rack cabinet. Always install servers and optional devices starting from the bottom of the rack cabinet.
- Rack mounted devices are not to be used as a shelf or work space. Do not place any object on top of rack mounted devices.
- Each rack cabinet might have more than one power cord. Be sure to disconnect all power cords in the rack cabinet before servicing any device in the rack cabinet.
- Connect all devices installed in a rack cabinet to power devices installed in the same rack cabinet. Do not plug a power cord from a device installed in one rack cabinet into a power device installed in a different rack cabinet.

- An electrical outlet that is not correctly wired could place hazardous voltage on the metal parts of the system or the devices that attach to the system. It is the responsibility of the customer to ensure that the outlet is correctly wired and grounded to prevent an electrical shock.

CAUTION:

- Do not install a unit in a rack where the internal rack ambient temperatures will exceed the manufacturer's recommended ambient temperature for all your rack mounted devices.
- Do not install a unit in a rack where the air flow is compromised. Ensure that air flow is not blocked or reduced on any side, front, or back of a unit used for air flow through the unit.
- Consideration should be given to the connection of the equipment to the supply circuit so that overloading of the circuits does not compromise the supply wiring or overcurrent protection. To provide the correct power connection to a rack, refer to the rating labels located on the equipment in the rack to determine the total power requirement of the supply circuit.
- (For sliding drawers) Do not pull out or install any drawer or feature if the rack stabilizer brackets are not attached to the rack. Do not pull out more than one drawer at a time. The rack may become unstable if you pull out more than one drawer at a time.
- (For fixed drawers) This drawer is a fixed drawer and should not be moved for servicing unless specified by the manufacturer. Attempting to move the drawer partially or completely out of the rack may cause the rack to become unstable or cause the drawer to fall out of the rack.

CAUTION:

- Removing components from the upper positions in the rack cabinet improves rack stability during relocation. Follow these general guidelines whenever you relocate a populated rack cabinet within a room or building:
- Reduce the weight of the rack cabinet by removing equipment starting at the top of the rack cabinet. When possible, restore the rack cabinet to the configuration of the rack cabinet as you received it. If this configuration is not known, you must do the following:
 - Remove all devices in the 32U position and above.

- Ensure that the heaviest devices are installed in the bottom of the rack cabinet.
- Ensure that there are no empty U-levels between devices installed in the rack cabinet below the 32U level.
- If the rack cabinet you are relocating is part of a suite of rack cabinets, detach the rack cabinet from the suite.
- Inspect the route that you plan to take to eliminate potential hazards.
- Verify that the route that you choose can support the weight of the loaded rack cabinet. Refer to the documentation that comes with your rack cabinet for the weight of a loaded rack cabinet.
- Verify that all door openings are at least 760 x 2032 mm (30 x 80 in.).
- Ensure that all devices, shelves, drawers, doors, and cables are secure.
- Ensure that the four leveling pads are raised to their highest position.
- Ensure that there is no stabilizer bracket installed on the rack cabinet during movement.
- Do not use a ramp inclined at more than ten degrees.
- Once the rack cabinet is in the new location, do the following:
 - Lower the four leveling pads.
 - Install stabilizer brackets on the rack cabinet.
 - If you removed any devices from the rack cabinet, repopulate the rack cabinet from the lowest position to the highest position.
- If a long distance relocation is required, restore the rack cabinet to the configuration of the rack cabinet as you received it. Pack the rack cabinet in the original packaging material, or equivalent. Also lower the leveling pads to raise the casters off of the pallet and bolt the rack cabinet to the pallet.

Power Cords

For your safety, Quantum provides a power cord with a grounded attachment plug to use with this Quantum product. To avoid electrical shock, always use the power cord and plug with a properly grounded outlet.

Quantum power cords used in the United States and Canada are listed by Underwriter's Laboratories (UL) and certified by the Canadian Standards Association (CSA).

For units intended to be operated at 115 volts: Use a UL-listed and CSA-certified cord set consisting of a minimum 18 AWG, Type SVT or SJT, three-conductor cord, a maximum of 15 feet in length and a parallel blade, grounding-type attachment plug rated 15 amperes, 125 volts.

For units intended to be operated at 230 volts (U.S. use): Use a UL-listed and CSA-certified cord set consisting of a minimum 18 AWG, Type SVT or SJT, three-conductor cord, a maximum of 15 feet in length and a tandem blade, grounding-type attachment plug rated 15 amperes, 250 volts.

For units intended to be operated at 230 volts (outside the U.S.): Use a cord set with a grounding-type attachment plug. The cord set should have the appropriate safety approvals for the country in which the equipment will be installed.

Quantum power cords for a specific country or region are usually available only in that country or region.

Product Recycling and Disposal

This unit must be recycled or discarded according to applicable local and national regulations. Quantum encourages owners of information technology (IT) equipment to responsibly recycle their equipment when it is no longer needed.

Notice: This mark applies only to countries within the European Union (EU) and Norway. Appliances are labeled in accordance with European Directive 2002/96/EC concerning waste electrical and electronic

equipment (WEEE). The Directive determines the framework for the return and recycling of used appliances as applicable throughout the European Union. This label is applied to various products to indicate that the product is not to be thrown away, but rather reclaimed upon end of life per this Directive.

In accordance with the European WEEE Directive, electrical and electronic equipment (EEE) is to be collected separately and to be reused, recycled, or recovered at end of life. Users of EEE with the WEEE marking per Annex IV of the WEEE Directive, as shown above, must not dispose of end of life EEE as unsorted municipal waste, but use the collection framework available to customers for the return, recycling and recovery of WEEE. Customer participation is important to minimize any potential effects of EEE on the environment and human health.

Battery Return Policy

This product may contain sealed lead acid, nickel cadmium, nickel metal hydride, lithium, or a lithium ion battery. Consult your user manual or service manual for specific battery information. The battery must be recycled or disposed of properly. Recycling facilities may not be available in your area. For information on disposal of batteries, contact your local waste disposal facility.

For Taiwan:

Please recycle batteries

For the European Union:

Batteries or packaging for batteries are labeled in accordance with European Directive 2006/66/EC concerning batteries and accumulators and waste batteries and accumulators. The Directive determines the framework for the return and recycling of used batteries and accumulators as applicable throughout the European Union. This label is applied to various batteries to indicate that the battery is not to be thrown away, but rather reclaimed upon end of life per this Directive.

In accordance with the European Directive 2006/66/EC, batteries and accumulators are labeled to indicate that they are to be collected separately and recycled at end of life. The label on the battery may also include a chemical symbol for the metal concerned in the battery (Pb for lead, Hg for mercury and Cd for cadmium). Users of batteries and accumulators must not dispose of batteries and accumulators as unsorted municipal waste, but use the collection framework available to customers for the return, recycling and treatment of batteries and

accumulators. Customer participation is important to minimize any potential effects of batteries and accumulators on the environment and human health due to the potential presence of hazardous substances.

For California:

Perchlorate Material - special handling may apply. See <http://www.dtsc.ca.gov/hazardouswaste/perchlorate>.

The foregoing notice is provided in accordance with California Code of Regulations Title 22, Division 4.5 Chapter 33. Best Management Practices for Perchlorate Materials. This product/part may include a lithium manganese dioxide battery which contains a perchlorate substance.

End of Life (EOL) Plan

This product is a purchased unit. Therefore, it is the sole responsibility of the purchaser to dispose of it in accordance with local laws and regulations at the time of disposal.

This product contains recyclable materials. The materials should be recycled where facilities are available and according to local regulations.

Chapter 2

Introduction

The Quantum LTO-8 Tape Drive is a high-performance, high-capacity data-storage device that is designed to back up and restore open systems applications. It is the sixth generation in the Ultrium series of products, and is available with a Serial Attached SCSI interface (SAS). This model incorporates the Linear Tape-Open (LTO) Quantum Ultrium 8 Half-High Tape Drive.

Figure 2 View of the drive

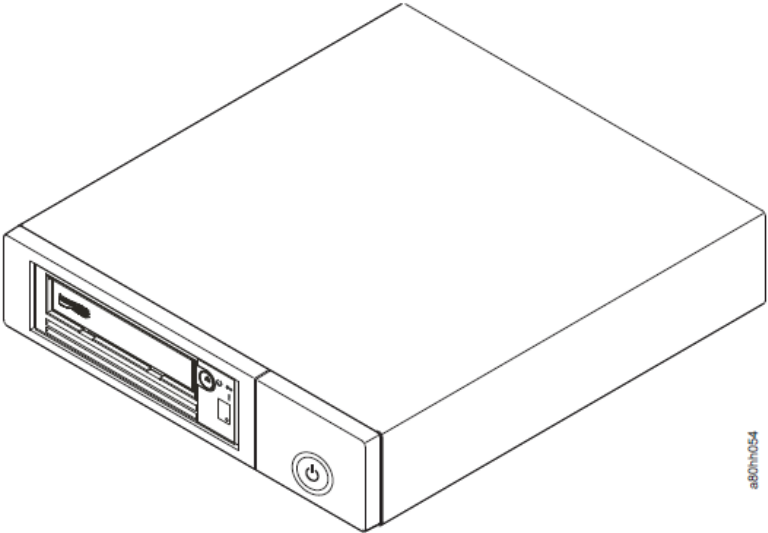

Drive Features

The drive offers the following features:

- Native storage capacity of 12000 GB per cartridge (30000 GB at 2.5:1 compression when using Ultrium 8 cartridges)
- Ability to use LTO-7 media in M8 format to expand capacity to 9000 GB
- Maximum native data transfer rate of up to 300 MB per second
- Burst data transfer rate of 600 MB per second
- Dual port 6 Gbps Serial Attached Small Computer Systems Interface (SAS)
- Half height form factor
- Support for WORM (Write Once Read Many) on WORM cartridge types
- 1GB read-and-write cache
- Support for encryption on Ultrium 7 and 8 tape cartridges
- Single Character Display (SCD) operator panel
- Ready, Fault, and Encryption status lights
- Maintenance Mode functions
- 1 Gbps Ethernet port for drive status and service
- LTFS capable

Front Panel of the Drive

Figure 3 Front panel
element descriptions

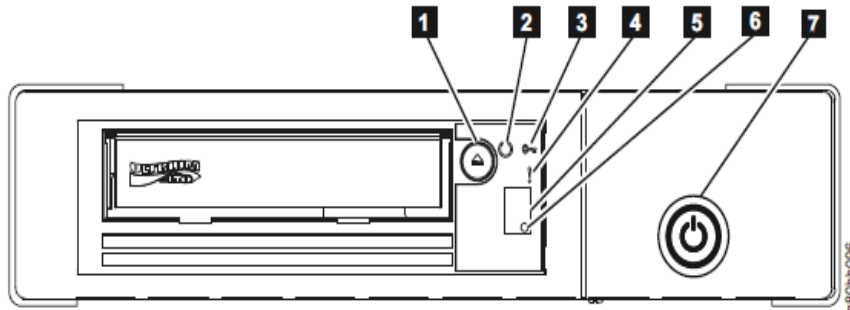

- 1 Cartridge unload button
- 2 Ready light (green)
- 3 Encryption light (white)
- 4 Fault light (amber)
- 5 Single Character Display (SCD)
- 6 SCD dot
- 7 Drive power button

Rear Panel of the Drive

Figure 4 Drive rear panel element descriptions

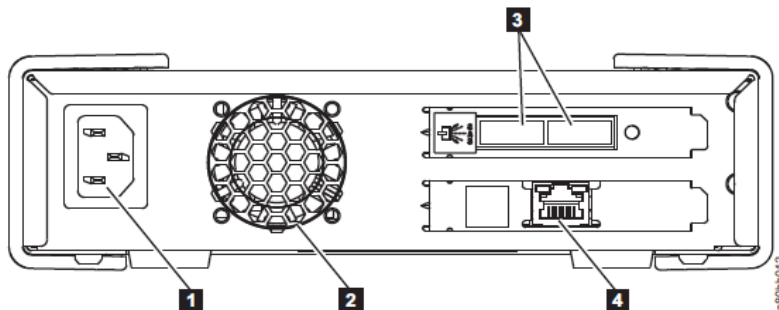

- 1 Power receptacle
- 2 Fan vent
- 3 SAS connectors
- 4 Ethernet connector (for drive status and service only)

Drive Performance

If you run applications that are highly dependent on tape-processing speed, take advantage of the significant performance improvements provided by this tape drive.

Table 1 Performance characteristics

Performance Characteristics	LTO-8 Tape Drive
Native data rate	300 MB/s (with Ultrium 8 media)
Maximum sustained data rate (at maximum compression)	600 MB/s
Burst data rate	600MB/s

Performance Characteristics	LTO-8 Tape Drive
Nominal load-to-ready time	12 seconds
Nominal unload time	17 seconds
Average rewind time	60 seconds

Note: Note: All sustained data rates are dependent on the capabilities of the interconnect.

By using the built-in data-compression capability of the tape drive, greater data rates than the native data transfer rate can be achieved. However, the actual throughput is a function of many components, such as the host system processor, disk data rate, block size, data compression ratio, SAS bus capabilities, and system or application software.

Cartridge Compatibility

The LTO-8 uses the Quantum LTO Ultrium 12000 GB Data Cartridge and is compatible with the cartridges of its predecessors, the Quantum Ultrium Tape Drive Generation 7. The drive performs the following functions:

- Reads and writes Ultrium 8 cartridges to Ultrium 8 format, including WORM and Data Encryption
- Reads and writes Ultrium 7 cartridges to Ultrium 7 format, including WORM and Data Encryption
- Reads and writes Ultrium 7 cartridges in M8 format
- Does not read or write Ultrium 6, 5, 4, 3, 2, and 1 cartridges

The drive reads tapes that are written by other licensed Ultrium 7, and 8 drives, and writes to tapes that are read by other licensed Ultrium 7 and 8 drives.

Speed Matching

To improve system performance, the drive uses a technique called speed matching to dynamically adjust its native (uncompressed) data rate to the slower data rate of a server. With speed matching, the drive operates at different speeds when reading or writing the Ultrium 7. Native data rates are as follows in the table below.

Table 2 Performance
Parameters

	Ultrium Generation Media	
	Generation 8 Media	Generation 7 Media
Speed matching data rates (MB/sec)	365.0	300.0
	341.0	287.52
	318.0	268.56
	306.4	250.66
	273.0	231.86
	249.5	213.06
	226.0	194.26
	203.0	175.46
	180.0	157.67
	157.5	138.52
	135.0	120.11
	112.0	101.46

If the server's net (compressed) data rate is between two of the preceding native data rates, the drive calculates the appropriate data rate at which to operate. Speed matching dramatically reduces backhitch, the condition that occurs when a tape stops, reverses, and

restarts motion. A backhitch is usually the result of a mismatch between the data rates of the server and the drive.

Channel Calibration

System performance is further optimized by a feature called channel calibration, in which the drive automatically customizes each read/write data channel to compensate for variations in such things as the recording channel's transfer function, the media, and characteristics of the drive head.

Data cartridge capacity scaling

The SET CAPACITY SCSI command enables a customer to capacity scale a data cartridge to enable faster random access. As an example, a customer could capacity scale a data cartridge to 20% of its normal length which improves the average access time by almost a factor of 5; however, it also reduces the native capacity of the tape to 1200 GB.

Encryption

The Quantum LTO-8 Tape Drive supports host Application Managed Encryption (AME), using T10 encryption methods. Data encryption is supported with LTO Ultrium 4 and later Data Cartridges only.

The encryption-enabled drive contains the necessary hardware and firmware to encrypt and decrypt host tape application data. Encryption policy and encryption keys are provided by the host application. A drive digital certificate is installed at manufacturing time. Each drive receives a unique serial number and certificate. The T10 Application can validate each drive instance by checking the drive's digital certificate.

Application-managed encryption is supported on AIX, Windows Server, Linux, and Solaris. Encryption requires the latest device drivers available on the web site: <http://www.quantum.com/serviceandsupport>.

Inhibiting Firmware Down-Leveling

The drive provides the capability to prevent loading and installing drive microcode by way of a Field Microcode Replace (FMR tape) if the firmware level contained in the FMR tape is older than the code level already installed. This option is controlled by the host application. No checking is done if the firmware level is loaded by way of the host interface or the library interface.

SAS Interface

The drive has a dual port 6 Gbps SAS (Serial Attached SCSI) host interface.

A drive with a SAS interface can be linked directly to controllers. SAS is a performance improvement over traditional SCSI because SAS enables multiple devices (up to 128) of different sizes and types to be connected simultaneously with thinner and longer cables; its full-duplex signal transmission supports 6.0 Gb/s. In addition, SAS drives can be hot-plugged.

SAS drives will auto-negotiate speed. There are no configurable topologies thus no feature switches associated with SAS.

Physical Characteristics

The drive contains a dual port, SFF-8088 SAS connector.

Supported Operating Systems

To determine the latest supported operating systems, visit the web at <http://www.quantum.com/serviceandsupport>. For specific instructions about attaching the drive, see [Chapter 3, Installation](#).

Supported Device Drivers

Quantum maintains the levels of device drivers for the drive on the Internet. You can access this material at the web site: <http://www.quantum.com/serviceandsupport>.

Note: If you do not have Internet access and you need information about device drivers, contact your Sales Representative.

Ethernet Port

The Quantum LTO-8 Tape Drive has a single 1 Gbps Ethernet port on the rear panel, with a RJ45 connector. The Default IP address is **169.254.0.3**, but the drive's IP address can be changed as needed.

The Ethernet port is used only for monitoring drive status and servicing the drive, not for data transmission.

IBM Spectrum Archive

The IBM Spectrum Archive linear tape file system (previously known as LTFS) is a file system that works with LTO Generation tape technology to access data stored on an IBM tape cartridge.

IBM Spectrum Archive uses the file system's format and resources of the operating system (OS) on which it is running to graphically display the contents of a tape cartridge in the OS's graphical user interface (GUI) format; typically a folder/tree structure. Using the host operating system's graphical file manager, reading data on a LTO tape cartridge is as easy as dragging and dropping. Users can run any application designed for disk files against tape data without concern for the fact that the data is physically stored on tape.

For more information on LTFS, visit <http://www.quantum.com/serviceandsupport>.

Specifications

The sections below give the physical, power, and environmental specifications for the drive. Specifications for tape cartridges are given in [Environmental specifications](#) on page 21.

Physical specifications

Specification	Measurement
Width	213 mm (8.4 in.)
Length	332 mm (13.1 in.)
Height	58 mm (2.3 in.)
Weight (without a cartridge)	4.3 kg (9.4 lbs.)

Power specifications

Power Measurements	Drive
AC line current	100 to 240 Vac
Line frequency	50 to 60 Hz, auto-ranging
Line current at 100 Vac	0.48 A
Line current at 240 Vac	0.20 A

Other specifications

Specification	Measurement
Maximum altitude for operating and storage	3048 m (10,000 ft)
Maximum altitude for shipping	12192 m (40,000 ft)

Environmental specifications

Environmental Factor	Measurement		
	Operating	Storage	Shipping
Temperature	10 to 38°C (50 to 100°F)	-40 to 60°C (-40 to 140°F)	-40 to 60°C (-40 to 140°F)
Relative humidity (non-condensing)	20 to 80%	10 to 90%	10 to 90%
Wet bulb temperature (maximum)	26°C (78.8°F)	Non-condensing	Non-condensing



Chapter 3 Installation

This is a customer setup unit. It is the customer's responsibility to install this product.

[Avoiding Drive Damage](#) on page 24

[Unpack the Drive](#) on page 24

[Verify the Shipment](#) on page 25

[Inspect the Power Cord and Outlet](#) on page 25

[Position the Tape Drive](#) on page 26

[Install the SAS Host Adapter Card \(if required\)](#) on page 26

[Connect the SAS Interface Cable](#) on page 26

[Connect Power](#) on page 28

[Run Drive Diagnostics](#) on page 29

[Install Device Drivers](#) on page 29

[Configure the Tape Drive to a Server/Host](#) on page 29

[Updating firmware](#) on page 30

Avoiding Drive Damage

To avoid static electricity damage when handling the drive, use the following precautions:

- Limit your movement. Movement can cause static electricity to build around you.
- Always handle the drive carefully. Never touch exposed circuitry.
- Prevent others from touching the drive.
- Before unpacking and installing the drive into an enclosure, touch its static-protective packaging to an unpainted metal surface on the enclosure for at least two seconds. This reduces static electricity in the packaging and your body.
- When possible, remove the drive from its static-protective packaging and install it directly into an enclosure without setting it down. When this is not possible, place the drive's packaging on a smooth, level surface and place the drive on the packaging.
- Do not place the drive on the cover of the enclosure or on any other metal surface.

Unpack the Drive

Unpack the drive and store the packaging for future moves or shipping.

Caution: If you return the unit for service, ship it in its original or equivalent packing material, or the warranty may be invalidated.

- 1 Inspect the unit for shipping damage. If there is damage, do not install the unit. Report the damage immediately by contacting your place of purchase.
- 2 Locate the label on the rear panel of the unit with the machine type, model number, and serial number of the unit. Make a note of these numbers and store them in an easily accessible place. Should you

need to contact Technical Support, you will be asked for these numbers.

Verify the Shipment

Ensure that the following items are included in the shipment:

- Power cord
- Quantum LTO Ultrium Cleaning Cartridge
- Single-connector SAS wrap tool
- Optional Rack Mount Kit
- The Quantum LTO-8 Tape Drive Quick Reference (6-68101-01)
- The Quantum LTO-8 HH SAS User's Guide 6-68132-03 (this guide)
- SAS cables are not part of the ship group. They must be ordered separately.

Inspect the Power Cord and Outlet

- 1 Inspect the power cord plug to ensure that it matches the power receptacle.
- 2 Ensure that all associated electrical outlets are properly grounded and that the circuit breaker is turned on.

WARNING: An electrical outlet that is not correctly wired could place hazardous voltage on metal parts of the system or the devices that attach to the system. It is the responsibility of the customer to ensure that the outlet is correctly wired and grounded to prevent an electrical shock.

Position the Tape Drive

Position the unit so it is convenient to the server. The only restrictions are the length of the power cord and the length of the cable to the server. Recommended locations are:

- Away from high-traffic areas, especially if the floor is carpeted.
- Out of printer or copy rooms to avoid toner and paper dust. Do not store paper supplies next to any unit.
- Away from moving air, such as doorways, open windows, fans, and air conditioners.
- Off the floor.
- In a horizontal position.
- Where the tape cartridge can be easily inserted.

The unit should not be stacked. Do not place anything on top of the unit.

Install the SAS Host Adapter Card (if required)

If there are no other devices attached to your server, a SAS host adapter card may need to be installed in the server. To install an adapter, refer to the instructions that accompany it.

Connect the SAS Interface Cable

Each tape drive is required to have a dedicated bus to the initiator, referred to as point-to-point connection. SAS architecture does not support multiple tape drives connected to a single host adapter port. The maximum SAS cable length that can be used to connect the host adapter to the tape drive is 5.5 m.

To connect the cable:

- 1 Ensure the tape drive is powered OFF.
- 2 Since there are several types of SAS connectors, verify the SAS cable has the correct connectors for the SAS host adapter and for the tape drive.
- 3 The tape drive has two SAS ports and can be connected to two servers, if desired. Refer to the appropriate figure that represents your configuration for cabling information (see [Figure 5](#) and [Figure 6](#)) and then connect the SAS cable(s) to SAS host adapter(s) and to the tape drive as shown.

Figure 5 Example of connecting one SAS device to the server

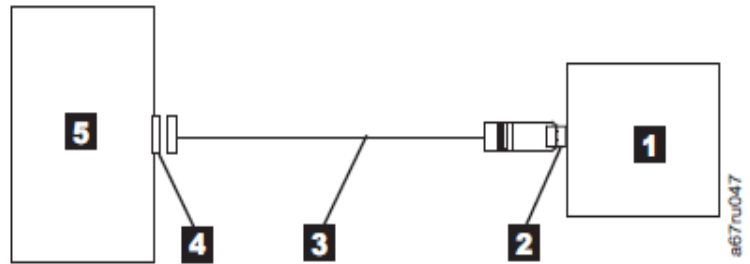

1 Tape drive	4 SAS host adapter card
2 SAS connector	5 Server
3 SAS cable	

Figure 6 Example of connecting the SAS device to two servers

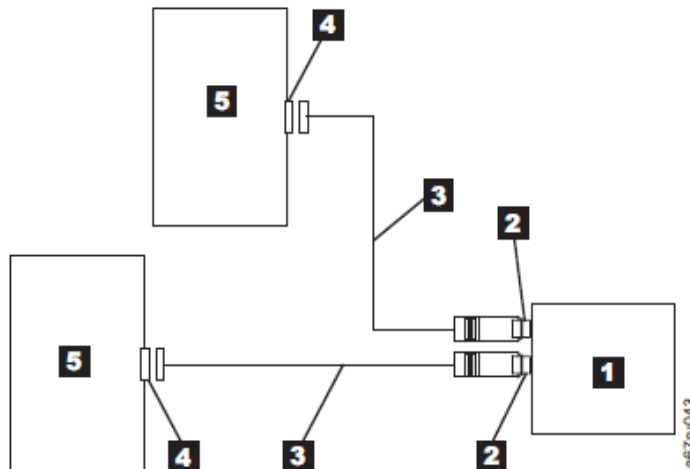

1 Tape drive	4 SAS host adapter card
2 SAS connectors	5 Servers
3 SAS cables	

- 4 Ensure the host adapter and the server are configured correctly for a SAS bus operation. Refer to the host adapter and server documentation for instructions.
- 5 If the power cord has already been installed, turn power to the tape drive ON.

Connect Power

- 1 If the power cord has already been installed, skip to step 3.
- 2 Plug the power cord into the rear panel (see [Figure 4](#) on page 14), then plug the other end into a grounded electrical outlet.
- 3 Power-on the unit by pressing the **Power** button. The POST runs, which checks all hardware except the drive head. During the POST, the Single-character Display (SCD) flashes several segmented

characters. Each segmented character represents a test performed during the POST. When the POST finishes, the SCD momentarily lights all segmented characters and then goes blank.

Run Drive Diagnostics

Run the Standalone Diagnostic (see [Function Code 1: Run Drive Diagnostics](#) on page 48).

Install Device Drivers

A device driver is firmware that enables the tape drive to interact with a variety of servers. See [Supported device drivers](#) on page 19 for instructions on downloading the latest device drivers.

If you intend to use the tape drive with a commercial software application, refer to that application's installation instructions to install the device driver and configure the tape drive.

Configure the Tape Drive to a Server/Host

- 1 Power-on the unit.
- 2 To configure the tape drive, refer to the documentation for your server/host and application software.

Updating firmware

Caution: When updating firmware, do not power-off the drive until the update is complete, or the firmware may be lost.

It is the customer's responsibility to ensure that this drive has the latest firmware. Periodically check for updated levels of drive firmware by visiting the web at <http://www.quantum.com/serviceandsupport>. Update drive firmware using:

- The host interface
- The xTalk tool
- A firmware update (FUP) tape cartridge

For instructions on obtaining a new firmware image, visit <http://www.quantum.com/serviceandsupport>. To update the firmware, refer to the following sections.

Updating Firmware through the Host Interface

Use xTalk SW to update your drive firmware. Refer to xTalk User Guide for more details, <http://www.quantum.com/serviceandsupport>.

Updating the firmware with an FUP tape cartridge

To update the drive's firmware from an FUP tape cartridge:

- 1 Create an FUP tape (see [Function Code 3: Create FUP Tape](#) on page 50). A single FUP tape can be used to update multiple drives if the drives are the same drive type (e.g. LTO Gen 8) and host interface (e.g. SAS).
- 2 Update the drive firmware (see [Function Code 2: Update Drive Firmware from FUP Tape](#) on page 50).

After updating the drive firmware, the FUP tape can be used as a data cartridge by using the "Unmake FUP Tape" function (see [Function Code 8: Unmake FUP Tape](#) on page 55).

The SCD presents a series of random characters during the firmware download and update. The SCD briefly displays 8, then becomes blank (not lit) when the firmware download and update is complete and there are no errors. An error code will be displayed if a firmware download or update error has been detected. The Ready light and the Fault light flash briefly during the firmware download and update. The Ready light turns On after the firmware download and update are complete.



Chapter 4 Operations

Operating the drive involves using the following front panel items:

- Power Button
- Single-character Display (SCD)
- SCD Dot
- Ready and Fault status lights
- Unload Button
- Encryption status light

Operating modes

The drive functions in the following modes:

- **Operation mode** - functions include reading and writing data, cartridge manipulation, error reporting, and firmware updating using an FUP cartridge. For more information, see [Status Lights](#) on page 35.
- **Maintenance mode** - functions include drive diagnostic, creation/unmake FUP cartridge, and drive dump manipulation (force to RAM,

copy to tape, copy to flash memory, and erase flash). For more information, see [Diagnostic and Maintenance Functions](#) on page 45.

The Unload button is used to switch between modes. For more information, see [Unload Button](#) on page 40.

Power Button

The **Power** button is a push button that turns the tape drive on or off. The button is located on the front panel (see 7 in [Figure 3](#) on page 13). When the **Power** button is in the off position, the primary electrical power within the enclosure is still active. To remove all electrical power to the enclosure, unplug the power cord from the receptacle at the rear of the drive.

When the unit is powered-on but idle, the Ready light (see 2 in [Figure 3](#) on page 13) is solid green; when it is performing a function, the **Ready** light is flashing green.

Single-character Display (SCD)

The SCD (5 in [Figure 3](#) on page 13) presents a single-character code for:

- Error conditions and informational messages
- Diagnostic or maintenance functions (while in maintenance mode only)

[Appendix A, Error Codes and Messages](#) lists the codes for error conditions and informational messages. If multiple errors occur, the code with the highest priority (represented by the lowest number) displays first. When the error is corrected, the code with the next highest priority displays, and so on until no errors remain.

[Diagnostic and Maintenance Functions](#) on page 45 lists the single-character codes that represent diagnostic or maintenance functions. To initiate a function the unit must be in maintenance mode.

The SCD is blank during normal operation.

SCD Dot

If a drive dump is present while the drive is in maintenance mode, a single dot illuminates in the lower right corner of the SCD (see 6 in [Figure 3](#) on page 13). To copy the dump, see [Function Code 5: Copy Drive Dump](#) on page 52.

The SCD Dot is on solid if the dump is in RAM memory. The SCD Dot flashes if the dump is in FLASH memory.

The SCD Dot turns off when you obtain a dump (by using xTalk or a SCSI command) or update the drive firmware.

Note: If the drive dump is stored in RAM memory (SCD Dot on solid), the dump will be lost when you turn OFF the power or reset the drive.

Status Lights

The status lights (2, 3 and 4 in [Figure 3](#) on page 13) are light-emitting diodes (LEDs) that provides information about the state of the drive. The Ready status light is green and the Fault status light is amber, and (when lit) solid or flashing.

Mode	SCD	Ready LED (green)	Fault LED (amber)
Operational	blank	On	Off
Activity (tape movement) in Operational Mode	blank	Flashing	Off
Maintenance	solid character	Flashing	On
Executing Maintenance Selection	flashing character	Off	On
Error Condition	solid character	Off	Flashing

Mode	SCD	Ready LED (green)	Fault LED (amber)
Power-On / Reset Initialization	random segments	Off	On

Note: The white Encryption status light will be on when the tape drive has a cartridge loaded and all data on this cartridge is encrypted (excluding the label). LTO Ultrium 8, 7, 6 and 5 cartridges only.

[Table 3](#) lists the conditions of the status lights and Single-character Display (SCD) and provides an explanation of what each condition means.

Table 3 Meaning of Status Lights and Single-character Display (SCD)

If green Ready Status Light is	and amber Fault Status Light is	and Encryption Status Light is	and SCD is	and SCD Dot is	Meaning
Off	Off	Off	Off	Off	The drive has no power or is powered off.
On	Off	On/Off	Off	Off	The drive is powered on and in an idle state.

If green Ready Status Light is	and amber Fault Status Light is	and Encryption Status Light is	and SCD is	and SCD Dot is	Meaning
Flashing (once per second)	Off	On/Off	Off	Off	The drive is reading from the tape, writing to the tape, rewinding the tape, locating data on the tape, loading the tape, or unloading the tape. Note: The white Encryption status light is on when all the data on the cartridge is encrypted (excluding the label). LTO Ultrium 8, Ultrium 7, Ultrium 6, and Ultrium 5 cartridges only.
Flashing (once per second)	Off	Off	Off	Off	If the drive contains a cartridge during the power-on cycle, the drive completes POST and slowly rewinds the tape (the process may take up to ten minutes). The light stops blinking and becomes solid when the drive completes the recovery and ejects the cartridge.
Off	On	Off	Displaying an error code or Maint Mode Function	On/Off	The drive is displaying error code(s) from the error code log on the SCD. For more information, see Function Code 9: Display Error Code Log on page 57 and Appendix A, Error Codes and Messages .

If green Ready Status Light is	and amber Fault Status Light is	and Encryption Status Light is	and SCD is	and SCD Dot is	Meaning
On/Off	On/Off	On/Off	Displaying random segments/ Blank/ displaying random segments/ displaying 8 /Blank	On/Off	<p>During power on, or a drive reset, the drive front panel will display drive progress as follows:</p> <ol style="list-style-type: none"> 1 SCD will display random segments (no Lights ON). 2 SCD will display random segments (Ready light ON). 3 SCD will display random segments (Fault light ON) 4 SCD will display [8] (Ready, Fault, and SCD Dot lights ON). 5 SCD will go blank (Ready light ON) after a successful power on or reset. <p>If an error is detected during the power on or reset, the tape drive posts an error code to the SCD. To determine the error, locate the code in Appendix A, Error Codes and Messages.</p>
Off	On	Off	0	On/Off	The drive is entering or exiting from maintenance mode. For more information, see Function Code 0: Maintenance Mode on page 49.
Off	On	Off	Flashing selected function	On/Off	The drive is executing the selected function while in maintenance mode.

If green Ready Status Light is	and amber Fault Status Light is	and Encryption Status Light is	and SCD is	and SCD Dot is	Meaning
Off	Flashing (once per second)	Off	Displaying error code	Off	An error occurred and the drive or media may require service, or it may require cleaning. Note the code on the SCD, then go to Appendix A, Error Codes and Messages to determine the action that is required.
Off	Flashing	Off	Displaying C	Off	The drive needs cleaning.
Off	Flashing	Off	Displaying Function Code 2 or Flashing	Off	The drive is updating firmware ¹ . The SCD will display a 2 if using an FUP cartridge. The SCD will be off if using the host interface. For more information, see Updating firmware on page 30.
Off	Flashing (twice per second)	Off	Off	Off	The drive detected an error and is performing a firmware recovery. It will reset automatically.
Off	On	Off	Flashing C	Off	The drive is requesting a cartridge to be loaded.
Off	Flashing (twice per second)	Off	Off	On	There is a drive dump in flash memory.

¹ Power should not be removed from the drive until the microcode update is complete. The drive indicates that the update is complete by resetting and performing POST.

Unload Button

The Unload button (1 in [Figure 3](#) on page 13) performs the following functions:

Table 4 Functions that the Unload button performs

Unload button Function	How to Initiate the Function
Rewind the tape into the cartridge and eject the cartridge from the drive	Press the Unload button once. The Ready light flashes while the drive is rewinding and unloading. Note: During a rewind and eject operation, the drive does not accept host interface commands.
Place the drive in maintenance mode	Ensure that the drive is unloaded. Then, within two seconds, press the Unload button three times. The drive is in maintenance mode when the Ready light is flashing and 0 appears in the SCD. Note: While in maintenance mode, the drive does not accept host interface commands. Note: If you attempt to enter Maintenance Mode with a cartridge in the drive, the drive will rewind and eject the cartridge. Remove the cartridge and repeat the steps for entering Maintenance Mode.
Scroll through the maintenance functions	While in maintenance mode, press the Unload button once per second to increment the display characters by one. When you reach the character of the diagnostic or maintenance function that you want (see Diagnostic and Maintenance Functions on page 45), press and hold the Unload button for three seconds.
Exit maintenance mode	Press the Unload button once per second to increment the display character until 0 displays. Then press and hold the Unload button for three seconds. Maintenance mode is exited when the Ready light is On and the SCD becomes blank.

Unload button Function	How to Initiate the Function
Force a drive dump (part of the maintenance mode)	<p>Caution: If the drive detects a permanent error and displays an error code, it automatically forces a drive dump (also known as a save of the firmware trace). If you force a drive dump, the existing dump will be overwritten and data will be lost. After you force a drive dump, do not turn off the power to the drive or you may lose the dump data.</p> <p>Choose one of the following procedures:</p> <ul style="list-style-type: none"> • If the drive is in maintenance mode (Ready light is flashing and Fault light is On for Maintenance mode), refer to Function Code 4: Force a Drive Dump on page 52. • If the drive is in operating mode (Ready light is On or flashing), press and hold the Unload button for ten seconds. <p>If captured dump data exists, the drive places it into a dump area (for information about retrieving the data, see Procedure 1: Determining Firmware Level and Capturing Drive Dump on page 83).</p>
Reset the drive	<p>Press and hold the Unload button until the drive begins the reset procedure (Fault light will turn On when reset starts).</p> <p>Note: If a tape cartridge is loaded in the drive the drive will unload the tape. Repeat the <i>Reset the drive</i> procedure after the tape is unloaded. The drive saves a dump of the current drive state, then reboots to allow communication. Do not cycle power as this will erase the contents of the dump.</p>

Inserting a Tape Cartridge

To insert a tape cartridge:

- 1 Ensure that the drive is powered-on.
- 2 Ensure that the write-protect switch on the tape cartridge is properly set (see [Write-Protect Switch](#) on page 76).

- 3 Grasp the cartridge so that the write-protect switch faces you (see 1 in [Figure 7](#) on page 42).
- 4 Slide the cartridge into the tape load compartment.

Note: If the cartridge is already in an ejected position and you want to reinsert it, remove the cartridge then insert it again. If the cartridge is already loaded and you cycle the power (turn it off, then on), the tape will reload.

Figure 7 Inserting a cartridge into the drive

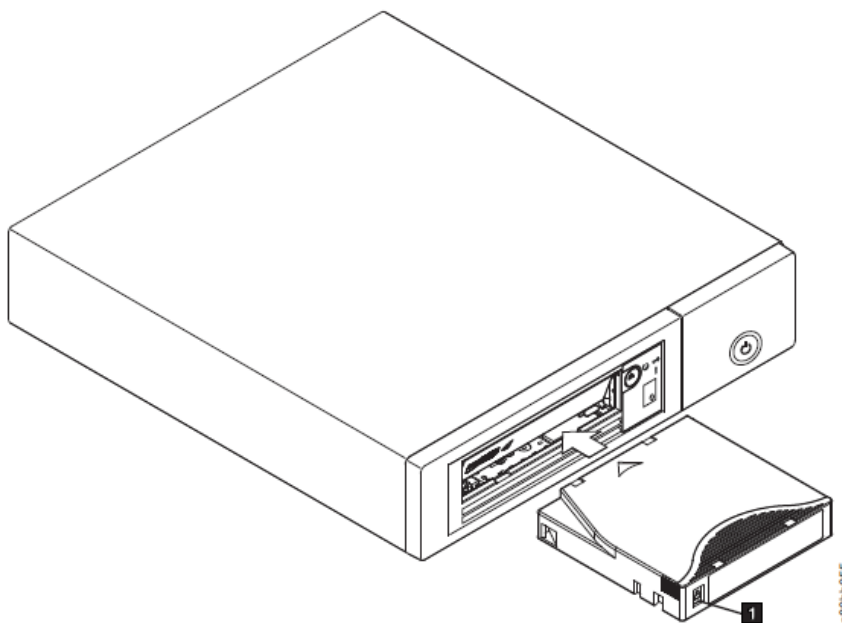

Caution: Do not attempt to load a cartridge when the drive is in Maintenance Mode until the drive requests it.

Removing a Tape Cartridge

To remove a tape cartridge:

- 1 Ensure that the drive is powered-on.
- 2 Press the **Unload** button. The drive rewinds the tape and partially ejects the cartridge. The **Ready** light flashes while the tape rewinds, then goes out before the cartridge partially ejects.
- 3 After the cartridge partially ejects, grasp the cartridge and remove it.

Note: Always remove an ejected cartridge before reinserting.

Whenever you unload a tape cartridge, the drive writes any pertinent information to the cartridge memory.

Mid-tape Recovery

If reset occurs while a cartridge is loaded, the drive will slowly rewind the tape and eject the cartridge. If a power cycle occurs while a cartridge is loaded, the drive will slowly rewind the tape. The drive will not automatically eject the cartridge.

If the tape is at EOT when the reset occurs, normally, it will take 2-3 minutes for the tape to rewind, but if a problem occurs during recovery, it can take up to an hour. Always give the drive time to recover following a power cycle with a tape in the drive.

The Ready light flashes and the SCD displays random segments during tape movement. Push the **Unload** button to eject the cartridge when the Ready light stops flashing.

Cleaning the Drive Head

Caution: When cleaning the drive head, use the Quantum LTO Ultrium Cleaning Cartridge. You may use another LTO cleaning cartridge, but it may not meet the standards of reliability established by Quantum.

Clean the drive head whenever **C** displays on the Single-character Display and the **Fault** light is flashing once per second. It is not recommended that you clean the drive head on a periodic basis; only when the drive requests to be cleaned.

Note: In Maintenance Mode, a flashing **C** with the **Fault** light On, means to insert a cartridge, not clean the drive head.

To clean the head, insert the cleaning cartridge into the tape load compartment (see [Figure 3](#) on page 13). The drive performs the cleaning automatically in less than two minutes then ejects the cartridge. The drive will perform a short **Load/Unload Test** while ejecting the drive. Wait for the drive to finish before removing the cartridge.

Note: The drive will automatically eject an expired cleaning cartridge.

The Quantum LTO Ultrium Cleaning Cartridge is valid for 50 uses.

Cleaning the Tape Drive

Clean the exterior surface of the tape drive with a damp towel. If a liquid all-purpose cleaner is used, apply it to the towel. Do not spray the tape drive.

Do not clean the interior of the tape drive; damage may result.

Diagnostic and Maintenance Functions

The drive can:

- Run diagnostics
- Test write and read functions
- Test a suspect tape cartridge
- Update firmware
- Perform other diagnostic and maintenance functions

The drive must be in maintenance mode to perform these functions.

Caution: Maintenance functions cannot be performed concurrently with read or write operations. While in maintenance mode, the tape drive does not accept host interface commands from the server.

[Table 5](#) on page 45 describes each diagnostic and maintenance function that the drive can perform, gives the function code which appears on the Single-character Display (SCD), and directs you to the instructions for performing the function. It is recommended that you use a customer-supplied scratch (blank) data cartridge for diagnostic testing.

Table 5 Diagnostic and maintenance functions

Function Code	Diagnostic or Maintenance Function	Instructions Location
0	Exit Maintenance Mode: Causes the drive to become available for reading and writing data.	Function Code 0: Maintenance Mode on page 49
1	Run Drive Diagnostics: Runs tests to determine whether the drive can properly load and unload cartridges, and read and write data.	Function Code 1: Run Drive Diagnostics on page 49

Function Code	Diagnostic or Maintenance Function	Instructions Location
2	Update Tape Drive Firmware from FUP Tape: Loads updated firmware from a firmware update (FUP) tape.	Function Code 2: Update Drive Firmware from FUP Tape on page 50
3	Create FUP Tape: Copies its firmware update (FUP) data to a customer-supplied scratch (blank) data cartridge.	Function Code 3: Create FUP Tape on page 51
4	Force a Drive Dump: Performs a dump of data (also known as saving a microcode trace).	Function Code 4: Force a Drive Dump on page 52
5	Copy Drive Dump: Copies data from a drive dump (captured by using Function Code 4) to the beginning of a customer-supplied scratch (blank) data cartridge, copies a drive dump to flash memory, or erases a dump from flash memory.	Function Code 5: Copy Drive Dump on page 52
6	Run Host Interface Wrap Test: Performs a check of the circuitry from and to the connector.	Function Code 6: Run Host Interface Wrap Test on page 54
7	Run RS-422 Wrap Test: This test causes the drive to perform a check of the circuitry and connector for the RS-422 interface.	Function Code 7: Run RS-422 Wrap Test on page 55
8	Unmake FUP Tape: Erases the FUP data on a customer-supplied scratch (blank) data cartridge and rewrite the cartridge memory on the tape. This turns the cartridge into a valid customer-supplied scratch data cartridge.	Function Code 8: Unmake FUP Tape on page 56
9	Display Error Code Log: Displays the last 10 error codes, one at a time (the codes are ordered; the most recent is presented first and the oldest (tenth) is presented last).	Function Code 9: Display Error Code Log on page 57

Function Code	Diagnostic or Maintenance Function	Instructions Location
A	Clear Error Code Log: Erases the contents of the error code log.	Function Code A: Clear Error Code Log on page 57
C	Insert Cartridge into Tape Drive: This function cannot be selected by itself, but is a part of other maintenance functions (such as Run Tape Drive Diagnostics and Create FUP Tape) that require a tape cartridge to be loaded.	Function Code C: Insert Cartridge into Tape Drive on page 58
E	Test Cartridge & Media: Performs tests to ensure that a suspect cartridge and its magnetic tape are acceptable.	Function Code E: Test Cartridge & Media on page 58
F	Write Performance Test: Performs tests to ensure that the drive can read from and write to tape.	Function Code F: Write Performance Test on page 59
H	Test Head: Performs tests to ensure that the tape drive's head and tape-carriage mechanics are working correctly.	Function Code H: Test Head on page 60
J	Fast Read/Write Test: Performs tests to ensure that the drive can read from and write to tape.	Function Code J: Fast Read/Write Test on page 61
L	Load/Unload Test: Tests the drive's ability to load and unload a tape cartridge.	Function Code L: Load/Unload Test on page 63
P	Enable Post Error Reporting: When selected, deferred-check conditions are reported to the host.	Function Code P: Post Error Reporting Enabled on page 64
U	Disable Post Error Reporting: When selected, deferred-check conditions are NOT reported to the host.	Function Code U: Post Error Reporting Disabled on page 64

Entering Maintenance Mode

The drive must be in maintenance mode to run drive diagnostics or maintenance functions. To place the unit in maintenance mode:

- 1 Make sure that no cartridge is in the drive.
- 2 Press the **Unload** button three times within two seconds. **0** appears in the Single-character Display (SCD) the Ready light is flashing, and the **Fault** light turns **On**.

Note: If a cartridge is in the tape drive, it will eject the first time that you press the Unload button and the drive will not be placed in maintenance mode. To continue placing the drive in maintenance mode, perform the preceding step. While in Maintenance Mode, the drive will not accept a cartridge unless the drive requests it. The SCD will display a flashing **C** to indicate a cartridge needs to be inserted.

Maintenance functions cannot be performed concurrently with read or write operations. While in maintenance mode, the drive does not receive host interface commands from the server.

Exiting Maintenance Mode

The drive must be in maintenance mode to run drive diagnostics or maintenance functions. To exit maintenance mode:

- 1 Press the **Unload** button once per second to increment the display character until **0** displays. Press and hold the Unload button for 3 or more seconds then release the button to take the drive out of maintenance mode. If no error is detected, **0** temporarily appears in the SCD, then goes blank. The drive then exits maintenance mode and the **Ready** light will turn **On**.
- 2 If an error is detected, the SCD shows an error code but still exits maintenance mode. To determine the error, locate the code in [Appendix A, Error Codes and Messages](#). To clear the error, turn the power off, then on again.

Note: The drive also exits maintenance mode automatically after it completes a maintenance function or after 10 minutes if no action has occurred.

Function Code 0: Maintenance Mode

Function Code 0 makes the drive available for running drive diagnostics or maintenance functions.

- 1 Place the drive in Maintenance Mode. For instructions, see [Entering Maintenance Mode](#) on page 48.
- 2 To exit Maintenance Mode, see [Exiting Maintenance Mode](#) on page 48.

The drive exits Maintenance Mode automatically after it completes a maintenance function or after 10 minutes if no action has occurred.

Function Code 1: Run Drive Diagnostics

Approximate Run Time = 5 minutes per loop

Total Number of Loops = 1

Function Code 1 runs tests that determine whether the drive can properly load and unload cartridges and read and write data.

Record the time it takes for the test to complete. Compare the recorded time with the “Approximate Run Time” above. If the test runs successfully but the execution time is significantly longer than the “Approximate Run Time”, run [Function Code F: Write Performance Test](#) on page 59. If the Write Performance Test fails, replace the media and exit maintenance mode.

Caution: For this test, insert only a scratch (blank) data cartridge or a cartridge that may be overwritten. During the test, the drive overwrites the data on the cartridge.

Note: If you inserted an invalid tape cartridge (e.g. Gen1 or WORM media), error code J or 7 appears in the SCD. If you inserted a write-protected cartridge, or the media has read-only compatibility (e.g., Gen2 media), error code P appears in the SCD. In either case, the tape drive unloads the cartridge and exits Maintenance Mode after the cartridge is removed.

Steps to Execute Run Drive Diagnostics:

- 1 Place the drive in Maintenance Mode. For instructions, see [Entering Maintenance Mode](#) on page 48.

- 2 Press the **Unload** button once per second until **1** appears in the SCD. (If you cycle past the desired code, press the Unload button once per second until the code reappears.)
- 3 Press and hold the **Unload** button for three or more seconds, then release it to select function **1**. Wait for the SCD to change to a flashing **C**.
- 4 Insert a scratch (blank) data cartridge. The SCD changes to a flashing **1** and the test begins. During the test, the drive will Unload/Load the cartridge. Do not remove the cartridge during the test.
 - If no error is detected, when the diagnostic ends, **0** temporarily appears in the SCD, and the tape drive exits Maintenance Mode.
 - If an error is detected, the **Fault** light flashes and the drive posts an error code to the SCD. To determine the error, locate the code in Error Codes and Messages. To clear the error either turn the power off and then on again, or reboot the drive by pressing and holding the Unload button for 10 seconds.

Function Code 2: Update Drive Firmware from FUP Tape

Caution: When updating drive firmware, do not power-off the drive until the update is complete or the firmware may be lost.

Function Code 2 loads drive firmware from a firmware update (FUP) tape. The FUP tape must have been created from a LTO-8 tape drive with the same host interface (e.g. SAS, Fibre Channel).

- 1 Place the drive in Maintenance Mode. For instructions, see [Entering Maintenance Mode](#) on page 48.
- 2 Press the Unload button once per second until **2** appears in the SCD. (If you cycle past the desired code, press the **Unload** button once per second until the code reappears.)
- 3 Press and hold the **Unload** button for three or more seconds, then release it to select the function. The SCD changes to a flashing **C**.
- 4 Insert the FUP tape cartridge. The SCD changes to a flashing **2**. The **Fault** light will be **ON** solid during tape movement and flashing while code is being loaded. The **Ready** light will be **OFF**. The tape drive loads the updated firmware from the FUP tape into its erasable programmable read-only memory (EPROM) area.

- If the update completes successfully, the tape drive rewinds and unloads the FUP tape, resets itself, and is ready to use the new firmware. The drive automatically reboots.
- If the update fails, the tape drive posts an error code to the SCD. To determine the error, locate the code in [Appendix A, Error Codes and Messages](#). Push the **Unload** button to eject the cartridge. The drive exits Maintenance Mode after the cartridge is removed. Contact Quantum Technical Support for problem determination or machine replacement.

Function Code 3: Create FUP Tape

Function Code 3 copies the drive's firmware update (FUP) data to a scratch data cartridge. The resulting FUP tape can only be used to update the firmware on other LTO-8 tape drives with the same host interface (SAS, or Fibre Channel).

Caution: For this function, insert only a scratch (blank) data cartridge or a cartridge that may be overwritten. During the test, the drive overwrites the data on the cartridge.

Note: If you inserted an invalid tape cartridge, error code **J** or **7** appears in the SCD. If you inserted a write-protected cartridge, or the media has read-only compatibility, error code **P** appears in the SCD. In either case, the tape drive unloads the cartridge and exits Maintenance Mode after the cartridge is removed.

- 1 Place the drive in Maintenance Mode. For instructions, see [Appendix 4, Entering Maintenance Mode](#).
- 2 Press the **Unload** button once per second until **3** appears in the SCD. (If you cycle past the desired code, press the Unload button once per second until the code reappears.)
- 3 Press and hold the **Unload** button for three or more seconds, then release it to select the function. The SCD changes to a flashing **C**.
- 4 Insert a scratch (blank) data cartridge that is not write protected (or the tape drive exits maintenance mode). The SCD changes to a flashing **3**. The tape drive copies the FUP data to the scratch data cartridge.

- If the tape drive creates the FUP tape successfully, it rewinds and unloads the new tape, exits Maintenance Mode, and the tape is ready to use.
- If the tape drive fails to create the FUP tape, it displays an error code. To determine the error, see [Appendix A, Error Codes and Messages](#). The tape drive then unloads the FUP tape, and exits Maintenance Mode after the cartridge is removed.

Function Code 4: Force a Drive Dump

Function Code 4 performs a dump of data collected by the drive (this process is also known as saving a microcode trace).

- 1 Place the drive in Maintenance Mode. For instructions, see [Entering Maintenance Mode](#) on page 48.
- 2 Press the **Unload** button once per second until **4** appears in the SCD. (If you cycle past the desired code, press the Unload button once per second until the code reappears.)
- 3 Press and hold the Unload button for three or more seconds, then release it to select the function. The drive performs the dump. The SCD shows **0**, then goes blank, and the drive exits Maintenance Mode. To access the contents of the dump, see [Function Code 5: Copy Drive Dump](#) on page 52

Note: You can also force a drive dump when the tape drive is in normal operating mode. Simply press and hold the **Unload** button for ten seconds. This causes the drive to reboot.

Function Code 5: Copy Drive Dump

Function Code 5 copies data from a drive dump (captured in **Function Code 4**) to the beginning of a scratch (blank) data cartridge.

Caution: For this function, insert only a scratch (blank) data cartridge or a cartridge that may be overwritten. During the test, the drive overwrites the data on the cartridge.

Note: If you inserted an invalid tape cartridge, error code **J** or **7** appears in the SCD. If you inserted a write-protected cartridge, or the media has read-only compatibility, error code **P** appears in the SCD. In either case, the tape drive unloads the cartridge and exits Maintenance Mode after the cartridge is removed.

- 1 Place the drive in Maintenance Mode. (For instructions, see [Entering Maintenance Mode](#) on page 48)
- 2 Press the Unload button once per second until **5** appears in the SCD. If you cycle past the desired code, press the Unload button once per second until the code reappears.
- 3 Press and hold the Unload button for three or more seconds, then release it to select the function.
- 4 Press the Unload button once per second to cycle through the following functions:
 - 5 - 0: no function
 - 5 - 1: copy dump to tape; clears RAM dump
 - 5 - 2: copy dump to flash memory; clears RAM dump
 - 5 - 3: erase flash memory

If you cycle past the desired code, press the Unload button once per second until the code reappears.

- 5 Press and hold the **Unload** button for three or more seconds, then release it to select one of the above functions.
- 6 If you selected **5 - 0** the drive will exit Maintenance Mode. If you selected **5 - 2** or **5 - 3** the SCD will change to a flashing **5** while the procedure is completing. After the procedure is completed the drive will exit Maintenance Mode. If you selected **5 - 1** the SCD will change to a flashing **C** indicating that a data cartridge is to be inserted.
- 7 Insert a scratch (blank) data cartridge within 60 seconds, or the drive will exit Maintenance Mode. Ensure the scratch cartridge is not write protected (or the tape drive exits maintenance mode). The SCD flashes the selection number while performing the function.
 - If the copy operation completes successfully, the tape drive rewinds and unloads the tape, and exits Maintenance Mode after the cartridge is removed.

- If the copy operation fails, an error code appears in the SCD. To determine the error, locate the code in [Appendix A, Error Codes and Messages](#). The tape drive unloads the tape cartridge and exits Maintenance Mode after the cartridge is removed.

Function Code 6: Run Host Interface Wrap Test

Approximate Run Time = 10 seconds per loop

Number of Loops = This test runs until stopped by pressing the **Unload** button.

Function Code 6 performs a check of the host interface circuitry and host connector on the drive.

- 1 Make sure that the host interface wrap plug is connected to the host interface connector at the rear of the drive.
 - Connect the wrap plug to the SAS port to be tested.
- 2 Place the drive in Maintenance Mode. For instructions, see [Entering Maintenance Mode](#) on page 48.
- 3 Press the Unload button once per second until **6** appears in the SCD. To test the SAS interface on the drive:
 - a Index through the Maintenance Mode options until **6** is displayed on the SCD.
 - b Press and hold the **Unload** button for three seconds to select **Function Code 6**.
 - c After selecting Function Code 6 the SCD will display option **6 - 1**.
 - d Press the **Unload** button within five seconds to make a different selection. If no other selection is made, the drive will perform option **6 - 1**.
- 4 Continue to press the Unload button once per second to cycle through the following functions:
 - 6 - 1: test the primary SAS port
 - 6 - 2: test the secondary SAS port
 - 6 - 3: test both primary and secondary SAS ports at the same time (requires a wrap plug in both ports)
 - 6 - 0: exit

- 5 Press and hold the **Unload** button for three or more seconds, then release it to select one of the above functions. The drive automatically starts the test. If you cycle past the desired code, press the **Unload** button once per second until the code reappears.
- 6 The SCD will display a flashing **6** during the test.
 - If no error is detected, the diagnostic will loop and begin again. To stop the loop, press the Unload button for one second and release. When the diagnostic ends, **0** temporarily appears in the SCD, and the tape drive exits Maintenance Mode.
 - If an error is detected, the Fault light flashes and the drive posts an error code to the SCD. To determine the error, locate the code in [Appendix A, Error Codes and Messages](#). To clear the error either turn the power off and then on again, or reboot the drive by pressing and holding the Unload button for 10 seconds.

Function Code 7: Run RS-422 Wrap Test

Note: This function is described here for information only. It is not supported on the LTO-6, 7 or 8 Tape Drives.

This test causes the drive to perform a check of the circuitry and connector for the RS-422 interface. This connector supports the Library Drive Interface (LDI) and the Automation Drive Interface (ADI).

Before selecting this function, attach an LDI or RS-422 wrap plug to the drive's LDI or RS-422 connector (in place of the LDI or RS-422 cable).

- 1 Make sure that no cartridge is in the drive, and the appropriate wrap plug is attached to the RS-422 connector.
- 2 Place the drive in Maintenance Mode. For instructions, see [Entering Maintenance Mode](#) on page 48.
- 3 Press the **Unload** button once per second until **7** appears in the Single-character Display (SCD). If you cycle past **7**, continue to press the **Unload** button until it displays again.
- 4 To select the function, press and hold the **Unload** button for three seconds. After you select the function, **7** flashes and the drive automatically starts the test.
 - If no error is detected, the diagnostic will loop and begin again. To stop the loop, press the **Unload** button for one second and

release. When the diagnostic ends, **0** temporarily appears in the SCD, and the tape drive exits Maintenance Mode.

- If an error is detected, the Fault light flashes and the drive posts an error code to the SCD. To determine the error, locate the code in [Appendix A, Error Codes and Messages](#). To clear the error either turn the power off and then on again, or reboot the drive by pressing and holding the **Unload** button for 10 seconds.

Function Code 8: Unmake FUP Tape

Function Code 8 erases the firmware update (FUP) data and rewrites the cartridge memory on the tape. This converts the cartridge into a valid scratch (blank) data cartridge.

- 1** Place the drive in maintenance mode. For instructions, see [Entering Maintenance Mode](#) on page 48.
- 2** Press the **Unload** button once per second until **8** appears in the SCD. (If you cycle past the desired code, press the **Unload** button once per second until the code reappears.)
- 3** Press and hold the **Unload** button for three or more seconds, then release it to select function **8**. The SCD changes to a flashing **C**, requesting a cartridge.
- 4** Insert the FUP data cartridge (or the tape drive exits maintenance mode). The SCD changes to a flashing **8**. The tape drive erases the firmware on the tape and rewrites the header in the cartridge memory to change the cartridge to a valid scratch (blank) data cartridge. The drive then ejects the cartridge and exits Maintenance Mode.

Note: If you inserted an invalid tape cartridge, error code **J** or **7** appears in the SCD. If you inserted a write-protected cartridge, or the media has read-only compatibility, error code **P** appears in the SCD. In either case, the tape drive unloads the cartridge and exits Maintenance Mode after the cartridge is removed.

- If the tape drive creates the scratch tape successfully, it rewinds and unloads the new tape, exits Maintenance Mode, and the tape is ready to use.
- If the tape drive fails to create the scratch tape, it displays an error code. To determine the error, see [Appendix A, Error Codes](#)

[and Messages](#). The tape drive then unloads the FUP tape, and exits Maintenance Mode after the cartridge is removed.

Function Code 9: Display Error Code Log

Function Code 9 displays the last ten error codes, one at a time (the codes are ordered; the most recent is presented first and the oldest is presented last). If there are no errors in the log, function code **0** displays in the Single-character Display (SCD) and exits Maintenance Mode.

- 1 Place the drive in Maintenance Mode. For instructions, see [Entering Maintenance Mode](#) on page 48.
- 2 Press the **Unload** button once per second until **9** appears in the SCD. (If you cycle past the desired code, press the **Unload** button once per second until the code reappears.)
- 3 Press the **Unload** button, then release it to view the most recent error code.
- 4 Press and release the **Unload** button again to view successive error codes. Let two to three seconds pass between each depression. The **Ready** light and **Fault** light will flash On/Off once for each successive error code. The SCD will display **0** when all the error codes have been displayed.
- 5 After viewing all error codes, exit this function by pressing the **Unload** button again. The SCD will display **0** and exit Maintenance Mode.

Function Code A: Clear Error Code Log

Function Code A erases the contents of the error code log.

- 1 Place the drive in Maintenance Mode. For instructions, see [Entering Maintenance Mode](#) on page 48.
- 2 Press the **Unload** button once per second until **A** appears in the SCD. (If you cycle past the desired code, press the **Unload** button once per second until the code reappears.)
- 3 Press and hold the **Unload** button for three or more seconds, then release it to select the function. **A** flashes in the SCD, followed by **0**. The tape drive erases all errors from the error code log and exits Maintenance Mode.

Function Code C: Insert Cartridge into Tape Drive

This function cannot be selected by itself, but is part of other maintenance functions (such as Run Tape Drive Diagnostics and Create FUP Tape) that require a tape cartridge to be inserted.

Function Code E: Test Cartridge & Media

Approximate Run Time = 15 minutes per loop

Total Number of Loops = 10

Function Code E performs tests that determine whether a suspect cartridge and its magnetic tape are acceptable.

Press the **Unload** button to stop the diagnostic and exit maintenance mode. Pressing the **Unload** button once will abort the test at the end of the current test loop. Pressing the **Unload** button twice will abort the test immediately. Wait for the drive to rewind the tape and unload the cartridge.

Caution: When you perform this test, data on the suspect tape will be overwritten.

Note: If you inserted an invalid tape cartridge, error code **J** or **7** appears in the SCD. If you inserted a write-protected cartridge, or the media has read-only compatibility, error code **P** appears in the SCD. In either case, the tape drive unloads the cartridge and exits Maintenance Mode after the cartridge is removed.

- 1 Place the drive in Maintenance Mode. For instructions, see [Entering Maintenance Mode](#) on page 48.
- 2 Press the **Unload** button once per second until **E** appears in the SCD. (If you cycle past the desired code, press the **Unload** button once per second until the code reappears.)
- 3 Press and hold the **Unload** button for three or more seconds, then release it to select the function. The SCD changes to a flashing **C** requesting a cartridge.
- 4 Ensure that the write-protect switch on the cartridge is off, then insert the cartridge (or the tape drive exits maintenance mode). The SCD changes to flashing **E**. The tape drive runs the tests.

- If no error is detected, the diagnostic will loop and begin again. To stop the loop, press the **Unload** button for one second and release. When the diagnostic ends, **0** temporarily appears in the SCD, and the tape drive exits Maintenance Mode.
- If an error is detected, the **Fault** light flashes and the drive posts an error code to the SCD. To determine the error, locate the code in [Appendix A, Error Codes and Messages](#). To clear the error either turn the power off and then on again, or reboot the drive by pressing and holding the **Unload** button for 10 seconds.

Function Code F: Write Performance Test

Approximate Run Time = 7 minutes per loop

Total Number of Loops = 10

Function Code F performs tests to ensure that the drive can read from and write to tape.

Press the **Unload** button to stop the diagnostic and exit maintenance mode. Pressing the **Unload** button once will abort the test at the end of the current test loop. Pressing the **Unload** button twice will abort the test immediately. Wait for the drive to rewind the tape and unload the cartridge.

Caution: For this test, insert only a scratch (blank) data cartridge or a cartridge that may be overwritten. During the test, the drive overwrites the data on the cartridge.

Note: If you inserted an invalid tape cartridge, error code **J** or **7** appears in the SCD. If you inserted a write-protected cartridge, or the media has read-only compatibility, error code **P** appears in the SCD. In either case, the tape drive unloads the cartridge and exits Maintenance Mode after the cartridge is removed.

- 1 Place the drive in Maintenance Mode. For instructions, see [Entering Maintenance Mode](#) on page 48.
- 2 Press the **Unload** button once per second until **F** appears in the SCD. (If you cycle past the desired code, press the **Unload** button once per second until the code reappears.)

- 3 Press and hold the **Unload** button for three or more seconds, then release it to select the function. The SCD changes to a flashing **C**.
- 4 Insert a scratch (blank) data cartridge. The SCD changes to a flashing **F** and the tape drive runs the tests.
 - If no error is detected, the diagnostic will loop and begin again. To stop the loop, press the **Unload** button for one second and release. When the diagnostic ends, **0** temporarily appears in the SCD, and the tape drive exits Maintenance Mode.
 - If an error is detected, the Fault light flashes and the drive posts an error code to the SCD. To determine the error, locate the code in [Appendix A, Error Codes and Messages](#). To clear the error either turn the power off and then on again, or reboot the drive by pressing and holding the **Unload** button for 10 seconds.

Function Code H: Test Head

Approximate Run Time = 12 minutes per loop

Total Number of Loops = 10

Function Code H performs tests to ensure that the tape drive's head and tape-carriage mechanics work correctly.

Once you begin this test, the diagnostic begins the loop sequence. Time the first loop by pressing the **Unload** button once to stop the diagnostic after the completion of the first loop, then record the time it takes for the test to complete. Compare the recorded time with the "Approximate Run Time" above. If the test runs successfully but the execution time is significantly longer than the "Approximate Run Time", run [Function Code F: Write Performance Test](#) on page 59. If the Write Performance Test fails, replace the media and exit maintenance mode.

Press the **Unload** button to stop the diagnostic and exit maintenance mode. Pressing the **Unload** button once will abort the test at the end of the current test loop. Pressing the **Unload** button twice will abort the test immediately. Wait for the drive to rewind the tape and unload the cartridge.

Caution: For this test, insert only a scratch (blank) data cartridge or a cartridge that may be overwritten. During the test, the drive overwrites the data on the cartridge.

Note: If you inserted an invalid tape cartridge, error code **J** or **7** appears in the SCD. If you inserted a write-protected cartridge, or the media has read-only compatibility, error code **P** appears in the SCD. In either case, the tape drive unloads the cartridge and exits Maintenance Mode after the cartridge is removed.

- 1 Place the drive in Maintenance Mode. For instructions, see [Entering Maintenance Mode](#) on page 48.
- 2 Press the **Unload** button once per second until **H** appears in the SCD. (If you cycle past the desired code, press the **Unload** button once per second until the code reappears.)
- 3 Press and hold the **Unload** button for three or more seconds, then release it to select the function. The SCD changes to a flashing **C**.
- 4 Insert a scratch (blank) data cartridge. The SCD changes to a flashing **H**. The tape drive runs the tests.
 - If no error is detected, the diagnostic will loop and begin again. To stop the loop, press the **Unload** button for one second and release. When the diagnostic ends, **0** temporarily appears in the SCD, and the tape drive exits Maintenance Mode.
 - If an error is detected, the Fault light flashes and the drive posts an error code to the SCD. To determine the error, locate the code in [Appendix A, Error Codes and Messages](#). To clear the error either turn the power off and then on again, or reboot the drive by pressing and holding the **Unload** button for 10 seconds.

Function Code J: Fast Read/Write Test

Approximate Run Time = 7 minutes per loop

Total Number of Loops = 10

Function Code J performs tests to ensure that the drive can read from and write to tape.

Once you begin this test, the diagnostic begins the loop sequence. Time the first loop by pressing the **Unload** button once to stop the diagnostic after the completion of the first loop, then record the time it takes for the test to complete. Compare the recorded time with the “Approximate Run Time” above. If the test runs successfully but the execution time is significantly longer than the “Approximate Run Time”, run [Function](#)

[Code F: Write Performance Test](#) on page 59. If the Write Performance Test fails, replace the media and exit maintenance mode.

Press the **Unload** button to stop the diagnostic and exit maintenance mode. Pressing the **Unload** button once will abort the test at the end of the current test loop. Pressing the **Unload** button twice will abort the test immediately. Wait for the drive to rewind the tape and unload the cartridge.

Caution: For this test, insert only a scratch (blank) data cartridge or a cartridge that may be overwritten. During the test, the drive overwrites the data on the cartridge.

Note: If you inserted an invalid tape cartridge, error code **J** or **7** appears in the SCD. If you inserted a write-protected cartridge, or the media has read-only compatibility, error code **P** appears in the SCD. In either case, the tape drive unloads the cartridge and exits Maintenance Mode after the cartridge is removed.

- 1 Place the drive in Maintenance Mode. For instructions, see [Entering Maintenance Mode](#) on page 48.
- 2 Press the **Unload** button once per second until **J** appears in the SCD. (If you cycle past the desired code, press the **Unload** button once per second until the code reappears.)
- 3 Press and hold the **Unload** button for three or more seconds, then release it to select the function. The SCD changes to a flashing **C**.
- 4 Insert a scratch (blank) data cartridge. The SCD changes to a flashing **J** and the tape drive runs the tests.
 - If no error is detected, the diagnostic will loop and begin again. To stop the loop, press the **Unload** button for one second and release. When the diagnostic ends, **0** temporarily appears in the SCD, and the tape drive exits Maintenance Mode.
 - If an error is detected, the Fault light flashes and the drive posts an error code to the SCD. To determine the error, locate the code in [Appendix A, Error Codes and Messages](#). To clear the error either turn the power off and then on again, or reboot the drive by pressing and holding the **Unload** button for 10 seconds.

Function Code L: Load/ Unload Test

Approximate Run Time = 30 seconds per loop

Total Number of Loops = 10

Function Code L tests the drive's ability to load and unload a tape cartridge.

Press the **Unload** button to stop the diagnostic and exit maintenance mode. Pressing the **Unload** button once will abort the test at the end of the current test loop. Pressing the **Unload** button twice will abort the test immediately. Wait for the drive to rewind the tape and unload the cartridge.

Caution: Even though no data is written during this test, it is recommended that you use a blank (scratch) cartridge for this test.

Note: If you inserted an invalid tape cartridge, error code **J** or **7** appears in the SCD. If you inserted a write-protected cartridge, or the media has read-only compatibility, error code **P** appears in the SCD. In either case, the tape drive unloads the cartridge and exits Maintenance Mode after the cartridge is removed.

- 1 Place the drive in Maintenance Mode. For instructions, see [Entering Maintenance Mode](#) on page 48.
- 2 Press the **Unload** button once per second until **L** appears in the SCD. (If you cycle past the desired code, press the **Unload** button once per second until the code reappears.)
- 3 Press and hold the **Unload** button for three or more seconds, then release it to select the function. The SCD changes to a flashing **C**.
- 4 Insert a scratch (blank) data cartridge. The SCD changes to a flashing **L** and the tape drive runs the tests.
 - If no error is detected, the diagnostic will loop and begin again. To stop the loop, press the **Unload** button for one second and release. When the diagnostic ends, **0** temporarily appears in the SCD, and the tape drive exits Maintenance Mode.
 - If an error is detected, the **Fault** light flashes and the drive posts an error code to the SCD. To determine the error, locate the code in [Appendix A, Error Codes and Messages](#). To clear the error either turn the power off and then on again, or reboot the

drive by pressing and holding the **Unload** button for 10 seconds.

Function Code P: Post Error Reporting Enabled

When Post Error Reporting is enabled, deferred-check conditions are reported to the host and temporary errors are reported in the sense data. **Function Code P** will be displayed in Maintenance Mode when the drive has Post Error Reporting enabled.

This selection is normally used as a request from support personnel.

- 1 Place the drive in Maintenance Mode. For instructions, see [Entering Maintenance Mode](#) on page 48.
- 2 Press the **Unload** button once per second until either **P** or **U** appears in the SCD. **P** or **U** will appear in the SCD to indicate the current setting for Post Error Reporting. If you cycle past the desired code, press the **Unload** button once per second until the code reappears.
- 3 Exit Maintenance Mode if you do not want to change the current setting for Post Error Reporting. For instructions, see [Exiting Maintenance Mode](#) on page 48.
- 4 To disable Post Error Reporting, Press and hold the **Unload** button for three seconds while **P** appears in the SCD. The SCD changes to **U** after you release the Unload Button.
- 5 Press the **Unload** button once per second to select another Maintenance Mode Function. To exit Maintenance Mode, refer to [Exiting Maintenance Mode](#) on page 48.

Function Code U: Post Error Reporting Disabled

When Post Error Reporting is disabled, deferred-check conditions are not reported to the host and temporary errors are not reported in the sense data. This is the normal (default) setting for the drive. When the drive has Post Error Reporting disabled, **Function Code U** will be displayed in Maintenance Mode. The drive will default to Post Error Reporting disabled after a reboot or power off/on cycle.

- 1 Place the drive in Maintenance Mode. For instructions, see [Entering Maintenance Mode](#) on page 48.
- 2 Press the **Unload** button once per second until either **P** or **U** appears in the SCD. **P** or **U** will appear in the SCD to indicate the current setting for Post Error Reporting. If you cycle past the desired code, press the **Unload** button once per second until the code reappears.

- 3 Exit Maintenance Mode if you do not want to change the current setting for Post Error Reporting. For instructions, see [Exiting Maintenance Mode](#) on page 48.
- 4 To disable Post Error Reporting, Press and hold the **Unload** button for three seconds while **P** appears in the SCD. The SCD changes to **U** after you release the Unload Button.
- 5 Press the Unload button once per second to select another Maintenance Mode Function. To exit Maintenance Mode, refer to [Exiting Maintenance Mode](#) on page 48.



Chapter 5

Media

Quantum Ultrium media is available in the following types:

- Data cartridge
- WORM (Write Once, Read Many) Cartridge
- Cleaning cartridge

To ensure that your Quantum Ultrium Tape Drive conforms to Quantum's specifications for reliability, use only Quantum LTO Ultrium tape cartridges. You may use other LTO-certified data cartridges, but they may not meet the standards of reliability that are established by Quantum.

Figure 8 The Quantum LTO Ultrium Data Cartridge

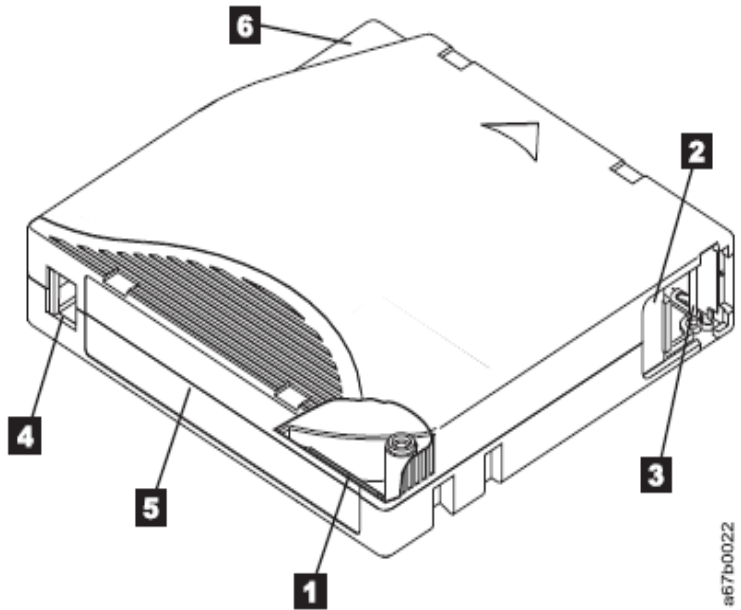

1	LTO cartridge memory
2	Cartridge door
3	Leader Pin
4	Write-protect Switch
5	Label area
6	Insertion guide

Data Cartridge

The different generations of Quantum Ultrium data cartridges can be identified by color:

Type	Color
Ultrium 8	Burgundy
Ultrium 8 WORM	Burgundy and Silvery gray
Ultrium 7 M8 Format	Purple
Ultrium 7	Purple
Ultrium 7 WORM	Purple and Silvery gray
Ultrium 6	Black
Ultrium 6 WORM	Black and Silvery gray
Ultrium 5	Burgundy
Ultrium 5 WORM	Burgundy and Silvery gray
Ultrium 4	Green
Ultrium 4 WORM	Green and Silvery gray
Ultrium 3	Slate Blue
Ultrium 3 WORM	Slate Blue and Silvery gray
Ultrium 2	Purple
Ultrium 1	Black

All generations contain 1/2-inch, dual-coat, magnetic tape.

You can order tape cartridges with the bar code labels included, or you can order custom labels.

When processing tape in the cartridges, Ultrium Tape Drives use a linear, serpentine recording format. The native data capacity and recording format of Ultrium data cartridges is as follows:

Data Cartridge	Native Data Capacity	Recording Format
Ultrium 8	12000 GB (30000 GB at 2.5:1 compression)	Reads and writes data on 6656 tracks, 32 tracks at a time
Ultrium 7 M8 format	9000 GB (22500 GB at 2.5:1 compression)	Reads and writes data on 5376 tracks, 32 tracks at a time
Ultrium 7	6000 GB (15000 GB at 2.5:1 compression)	Reads and writes data on 3584 tracks, 32 tracks at a time
Ultrium 6	2500 GB (6250 GB at 2.5:1 compression)	Reads and writes data on 2176 tracks, sixteen tracks at a time
Ultrium 5	1500 GB (300 GB at 2:1 compression)	Reads and writes data on 1280 tracks, sixteen tracks at a time
Ultrium 4	800 GB (1600 GB at 2:1 compression)	Reads and writes data on 896 tracks, sixteen tracks at a time
Ultrium 3	400 GB (800 GB at 2:1 compression)	Reads and writes data on 704 tracks, sixteen tracks at a time
Ultrium 2	200 GB (400 GB at 2:1 compression)	Reads and writes data on 512 tracks, eight tracks at a time
Ultrium 1	100 GB (200 GB at 2:1 compression)	Reads and writes data on 384 tracks, eight tracks at a time

The first set of tracks is written from near the beginning of the tape to near the end of the tape. The head then repositions to the next set of tracks for the return pass. This process continues until all tracks are written and the cartridge is full, or until all data is written.

The cartridge door (2 in [Figure 8](#) on page 68) protects the tape from contamination when the cartridge is out of the drive. The tape is attached to a leader pin (3 in [Figure 8](#) on page 68) behind the door. When the cartridge is inserted into the drive, a threading mechanism pulls the pin (and tape) out of the cartridge, across the drive head, and onto a non-removable take-up reel. The head can then read or write data from or to the tape.

The write-protect switch (4 in [Figure 8](#) on page 68) prevents data from being written to the tape cartridge. For more information, see [Write-Protect Switch](#) on page 77.

The label area (5 in [Figure 8](#) on page 68) provides a location to place a label. For more information, see [Bar Code Labels](#) on page 75.

The insertion guide (6 in [Figure 8](#) on page 68) is a large, notched area that prevents the cartridge from being inserted incorrectly.

Table 6

Type	Load/Unload Cycles
Ultrium 8	20,000 (20k)
Ultrium 7	20,000 (20k)
Ultrium 6	20,000 (20k)
Ultrium 5	20,000 (20k)
Ultrium 4	20,000 (20k)
Ultrium 3	20,000 (20k)
Ultrium 2	10,000 (10k)
Ultrium 1	5000 (5k)

Cartridge Compatibility

Table 7 Ultrium cartridge compatibility with Ultrium tape drives

Quantum Ultrium Tape Drive	Quantum LTO Ultrium Data Cartridges					
	12000 GB Ultrium 8	6000 GB Ultrium 7	2500 GB Ultrium 6	1500 GB Ultrium 5	800 GB (Ultrium 4)	400 GB (Ultrium 3)
Ultrium 8	Read/Write	Read/Write				
Ultrium 7 M8 format	Read/Write	Read/Write				

Quantum Ultrium Tape Drive	Quantum LTO Ultrium Data Cartridges					
	12000 GB Ultrium 8	6000 GB Ultrium 7	2500 GB Ultrium 6	1500 GB Ultrium 5	800 GB (Ultrium 4)	400 GB (Ultrium 3)
Ultrium 7		Read/Write	Read/Write	Read Only		
Ultrium 6			Read/Write	Read/Write	Read only	
Ultrium 5				Read/Write	Read/Write	Read only
Ultrium 4					Read/Write	Read/Write

Capacity Scaling

To control the capacity of the cartridge (for example, to obtain a faster seek time) issue the SCSI command **SET CAPACITY**. For information about this command, refer to the Quantum System Storage Ultrium Tape Drive SCSI Reference.

WORM (Write Once, Read Many) Cartridge

Certain records retention and data security applications require a Write Once, Read Many (WORM) method for storing data on tape. The LTO Ultrium 4 and later drives enable WORM support when a WORM tape cartridge is loaded into the drive.

Note: WORM format is not available for Ultrium 7 M8 format cartridges.

Worm Media

Because standard read/write media are incompatible with the WORM feature, a specially formatted WORM tape cartridge (see [Figure 9](#) on page 73) is required. Each WORM cartridge has a unique, worldwide cartridge identifier (WWCID), which comprises the unique CM chip serial number and the unique tape media serial number.

Figure 9 Ultrium Data and
WORM Tape Cartridges

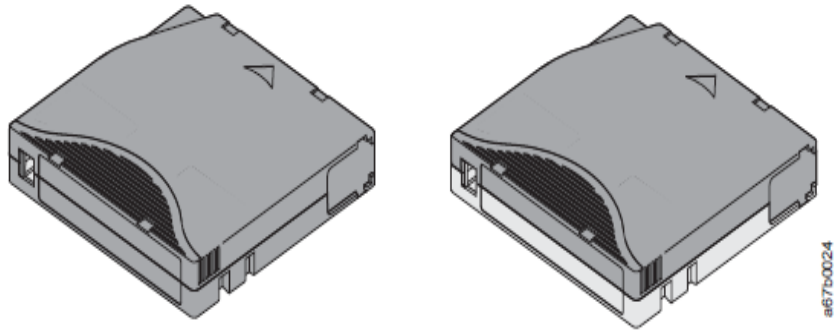

Data Security on WORM Media

Certain built-in security measures help ensure that the data written on a WORM cartridge does not become compromised, for example:

- The format of a WORM Tape Cartridge is unlike that of standard read/write media. This unique format prevents a drive that lacks WORM-capable firmware from writing on a WORM tape cartridge. For LTO 8, native data capacity is 12000 GB and compressed data capacity is 30000 GB.
- When the drive senses a WORM cartridge, the firmware prohibits the changing or altering of user data already written on the tape. The firmware notes the last point on the tape that can be appended.

WORM Media Errors

The following conditions cause WORM media errors to occur:

- Information in the servo manufacturer's word (SMW) on the tape must match information from the cartridge memory (CM) module in the cartridge. If it does not match, a media **Error Code 7** will post on the drive's single-character display (SCD).

Requirements for WORM Capability

To add WORM capability to your Quantum LTO Ultrium 8 drive(s), you need to use:

- Quantum Ultrium 8 12000 GB WORM tape cartridges

- Quantum Ultrium 7 6000 GB WORM tape cartridges

Cleaning Cartridge

A specially labeled Quantum LTO Ultrium Cleaning Cartridge is used to clean the drive head. The drive itself determines when a head needs to be cleaned. It alerts you by the SCD flashing a C. To clean the head manually, insert a cleaning cartridge into the tape load compartment (see [Figure 7](#) on page 42). The drive performs the cleaning automatically. When the cleaning is finished, the drive ejects the cartridge, and the SCD will be blank.

Note: The drive will automatically eject an expired cleaning cartridge without running the cleaning process. Replace the expired cleaning cartridge with a new cleaning cartridge and insert it into the drive.

The Quantum Cleaning Cartridge is valid for 50 uses. The cartridge's LTO-CM chip tracks the number of times that the cartridge is used.

Caution: After 50 uses, the cleaning cartridge expires. It is no longer usable, and must be replaced.

Cartridge Memory Chip (LTO-CM)

All generations of the Quantum LTO Ultrium Data Cartridges include a Linear Tape-Open Cartridge Memory (LTO-CM) chip (1 in [Figure 8](#) on page 68), that contains information about the cartridge and the tape (such as the name of the manufacturer that created the tape), as well as statistical information about the cartridge's use. The LTO-CM enhances the efficiency of the cartridge. For example, the LTO-CM stores the end-of-data location which, when the next time this cartridge is inserted and the Write command is issued, enables the drive to quickly locate the recording area and begin recording. The LTO-CM also aids in determining the reliability of the cartridge by storing data about its age, how many times it has been loaded, and how many errors it has accumulated. Whenever a tape cartridge is unloaded, the tape drive writes any pertinent information to the cartridge memory.

The storage capacity of the LTO Generation 6, 7, and 8 LTO-CM is 16320 bytes. The storage capacity of the LTO Generation 4 and 5 LTO-CM is 8160 bytes. LTO Generations 1, 2, and 3 have an LTO-CM capacity of 4096 bytes.

LTO-8 Type M Format

LTO-8 introduces a new media formatting option, the M format. The M format is used with LTO-8 tape drives and LTO-7 media. When LTO-7 media is M formatted by an LTO-8 tape drive, the data capacity of the LTO-7 media is 9TB native, compared to 6TB of a standard formatted LTO-7 tape. The LTO-7 media must be unused. After M formatting, the media cannot be used in an LTO-7 drive.

A new bar code media identifier is used with M formatted LTO-7 tapes. The last two characters of the bar code are "M8". Quantum strongly recommends that M formatted media are labelled with M8 bar code labels.

Bar Code Labels

A bar code label contains:

- A volume serial number (VOLSER) that is human-readable
- A bar code that the library can read
- Bar codes should be cartridge generation specific, i.e. an LTO8 tape should have a barcode with an L8 suffix.

Note: LTO7 tapes formatted to the M8 format should have a Barcode with an M8 suffix.

Note: The tape drive does not require bar code labels, but you may choose to use labels for tape cartridge identification purposes.

When attaching a bar code label to a tape cartridge, place the label only in the recessed label area (see 5 in [Figure 8](#) on page 68). A label that extends outside of the recessed area can cause loading problems in the drive.

Caution: Do not place any type of mark on the white space at either end of the bar code.

Figure 10 Sample bar code label on the LTO Ultrium 8 Tape Cartridge

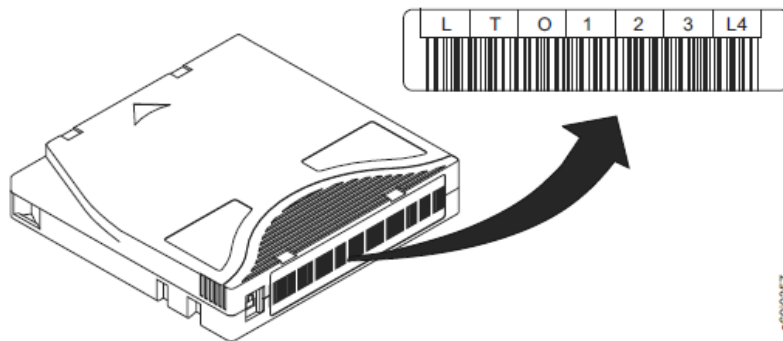

Guidelines for Using Bar Code Labels

Apply the following guidelines whenever using bar code labels:

- Use only Quantum-approved bar code labels.
- Do not reuse a label or reapply a used label over an existing label.
- Before you apply a new label, remove the old label by slowly pulling it at a right angle to the cartridge case.
- Use peel-clean labels that do not leave a residue after being removed. If there is glue residue on the cartridge, remove it by gently rubbing it with your finger. Do not use a sharp object, water, or a chemical to clean the label area.
- Examine the label before applying it to the cartridge. Do not use the label if it has voids or smears in the printed characters or bar code.
- Remove the label from the label sheet carefully. Do not stretch the label or cause the edges to curl.
- Position the label within the recessed label area (see 5 in [Figure 8](#) on page 68).
- With light finger pressure, smooth the label so that no wrinkles or bubbles exist on its surface.

- Verify that the label is smooth and parallel, and has no roll-up or roll-over. The label must be flat to within 0.5 mm (0.02 in.) over the length of the label and have no folds, missing pieces, or smudges.
- Do not place other machine-readable labels on other surfaces of the cartridge. They may interfere with the ability of the drive to load the cartridge.

Write-Protect Switch

The position of the write-protect switch on the tape cartridge (see 1 in [Figure 11](#) on page 77) determines whether you can write to the tape. If the switch is set to:

- The locked position (solid red), data cannot be written to the tape.
- The unlocked position (black void), data can be written to the tape.

If possible, use your server's application software to write-protect your cartridges (rather than manually setting the write-protect switch). This allows the server's software to identify a cartridge that no longer contains current data and is eligible to become a scratch (blank) data cartridge. Do not write-protect scratch (blank) cartridges; the tape drive will not be able to write new data to them.

If you must manually set the write-protect switch, slide it left or right to the desired position.

Figure 11 Setting the write-protect switch

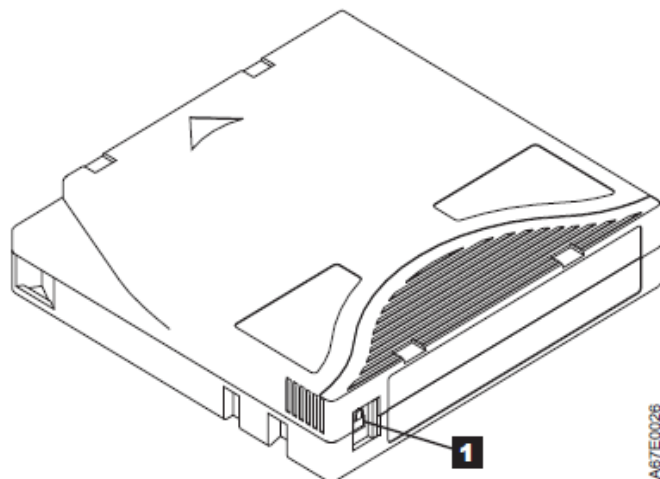

Handling Cartridges

Caution: Do not insert a damaged tape cartridge into the drive. A damaged cartridge can interfere with the reliability of a drive and may void the warranties of the drive and the cartridge. Before inserting a tape cartridge, inspect the cartridge case, cartridge door, and write-protect switch for breaks.

Incorrect handling or an incorrect environment can damage cartridges or their magnetic tape. To avoid damage to your tape cartridges and to ensure the continued high reliability of your Quantum LTO Ultrium Tape Drives, use the following guidelines.

Provide Training

- Post procedures that describe proper media handling in places where people gather.
- Ensure that anyone who handles tape has been properly trained in handling and shipping procedures. This includes operators, users, programmers, archival services, and shipping personnel.
- Ensure that any service or contract personnel who perform archiving are properly trained in media-handling procedures.
- Include media-handling procedures as part of any services contract.
- Define and make personnel aware of data recovery procedures.

Ensure Proper Packaging

- When shipping a cartridge, use the original or better packaging.
- Always ship or store a cartridge in a jewel case.
- Use only a recommended shipping container that securely holds the cartridge in its jewel case during transportation.
- Never ship a cartridge in a commercial shipping envelope. Always place it in a box or package.
 - If you ship the cartridge in a cardboard box or a box of a sturdy material, ensure the following:

- Place the cartridge in polyethylene plastic wrap or bags to protect it from dust, moisture, and other contaminants.
- Double-box the cartridge (place it inside a box, then place that box inside the shipping box) and add padding between the two boxes.

Provide Proper Acclimation and Environmental Conditions

- Before using a cartridge, let it acclimate to the normal operating environment for 1 hour. If condensation is visible on the cartridge, wait an additional hour.
- Ensure that all surfaces of a cartridge are dry before inserting it.
- Do not expose the cartridge to moisture or direct sunlight.
- Do not expose recorded or blank cartridges to stray magnetic fields of greater than 100 oersteds (for example, terminals, motors, video equipment, X-ray equipment, or fields that exist near high-current cables or power supplies). Such exposure can cause the loss of recorded data or make the blank cartridge unusable.
- Maintain the conditions that are described in [Environmental and Shipping Specifications for Tape Cartridges](#) on page 81.

Perform a Thorough Inspection

After purchasing a cartridge and before using it, perform the following steps:

- Inspect the cartridge's packaging to determine potential rough handling.
- When inspecting a cartridge, open only the cartridge door. Do not open any other part of the cartridge case. The upper and lower parts of the case are held together with screws; separating them destroys the usefulness of the cartridge.
- Inspect the cartridge for damage before using or storing it.
- Inspect the rear of the cartridge (the part that loads first into the tape load compartment) and ensure that there are no gaps in the seam of the cartridge case (see 1 in [Figure 11](#) on page 77 and 4 [Figure 12](#) on page 80). If there are gaps in the seam (see [Figure 11](#) on page 77), the leader pin may be dislodged.

Figure 12 Checking for gaps in the seams of a cartridge

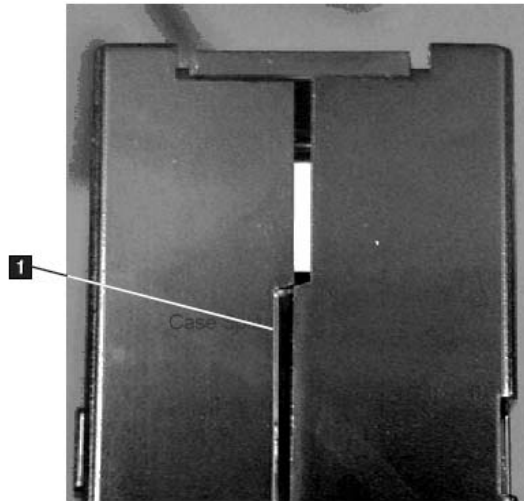

- Check that the leader pin is properly seated.
- If you suspect that the cartridge has been mishandled but it appears usable, copy any data onto a good cartridge immediately for possible data recovery. Discard the mishandled cartridge.
- Review handling and shipping procedures.

Handle the Cartridge Carefully

- Do not drop the cartridge. If the cartridge drops, slide the cartridge door back and ensure that the leader pin is properly seated in the pin-retaining spring clips (see 2 in Figure D-1 on page D-2).
- Do not handle tape that is outside the cartridge. Handling the tape can damage the tape's surface or edges, which may interfere with read or write reliability. Pulling on tape that is outside the cartridge can damage the tape and the brake mechanism in the cartridge.
- Do not stack more than six cartridges.
- Do not degauss a cartridge that you intend to reuse. Degaussing makes the tape unusable.

Examples of Cartridge Problems

Example: Split Cartridge Case

The cartridge's case is damaged. There is a high possibility of media damage and potential loss. Perform the following steps:

- 1 Look for cartridge mishandling.
- 2 Use the Quantum Leader Pin Reattachment Kit (part number 08L9129) to correctly seat the pin. Then, immediately use data recovery procedures to minimize chances of data loss.
- 3 Review media-handling procedures.

Environmental and Shipping Specifications for Tape Cartridges

Before you use a tape cartridge, acclimate it to the operating environment to prevent condensation in the drive (the time will vary, depending on the environmental extremes to which the cartridge was exposed).

The best storage container for the cartridges (until they are opened) is the original shipping container. The plastic wrapping prevents dirt from accumulating on the cartridges and partially protects them from humidity changes.

When you ship a cartridge, place it in its jewel case or in a sealed, moisture-proof bag to protect it from moisture, contaminants, and physical damage. Ship the cartridge in a shipping container that has enough packing material to cushion the cartridge and prevent it from moving within the container.

[Table 8](#) on page 82 gives the environment for operating, storing, and shipping LTO Ultrium Tape Cartridges.

Table 8 Environment for operating, storing, and shipping LTO media

Environmental Specifications				
Environmental Factor	Operating	Operational Storage ¹	Archival Storage ²	Shipping
Temperature	10 to 45°C (50 to 113°F)	16 to 32°C (61 to 90°F)	16 to 25°C (61 to 77°F)	-23 to 49°C (-9 to 120°F)
Relative humidity (non-condensing)	10 to 80%	20 to 80%	20 to 50%	5 to 80%
Maximum wet bulb temperature	26°C (79°F)	26°C (79°F)	26°C (79°F)	26°C (79°F)

1. The short term or operational storage environment is for storage durations of up to six months.
2. The long term or archival storage environment is for durations of six months up to ten years.

Disposing of Tape Cartridges

Under the current rules of the U.S. Environmental Protection Agency (EPA), regulation 40CFR261, the LTO Ultrium Tape Cartridge is classified as non-hazardous waste. As such, it may be disposed of in the same way as normal office trash. These regulations are amended from time to time, and you should review them at the time of disposal.

If your local, state, country (non-U.S.A.), or regional regulations are more restrictive than EPA 40CFR261, you must review them before you dispose of a cartridge. Contact your account representative for information about the materials that are in the cartridge.

If a tape cartridge must be disposed of in a secure manner, you can erase the data on the cartridge with a high-energy ac degausser (use a minimum of 4000 oersted peak field over the entire space that the cartridge occupies). The tape must make two passes through the field at 90 degree orientation change for each pass to achieve complete erasure. Some commercial degaussers have two magnetic field regions

offset 90 degrees from each other to accomplish complete erasure in one pass for higher throughput. Degaussing makes the cartridge unusable.

If you burn the cartridge and tape, ensure that the incineration complies with all applicable regulations.

Chapter 5: Media
Disposing of Tape Cartridges

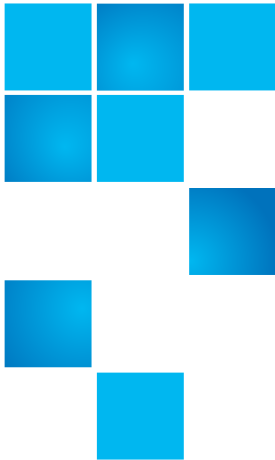

Chapter 6

Troubleshooting

If you encounter problems when running the drive, refer to the explanations of codes on the Single-character Display (SCD), see [Single-character Display \(SCD\)](#) on page 34. Please review the [Pre-Call Checklist](#) on page 89 before calling Quantum Technical Support.

Procedure 1: Determining Firmware Level and Capturing Drive Dump

Customers are responsible for updating Firmware. For optimum performance, the customer must obtain the latest level of firmware for the unit by downloading the firmware from the web site <http://www.quantum.com/serviceandsupport>.

Perform the following steps to determine the current firmware level installed on the drive.

- 1 Use the xTalk utility (available on the web at <http://www.quantum.com/serviceandsupport>) to view the current drive firmware level.
- 2 Compare this level with the latest available firmware level by visiting the same website. For additional information about using the xTalk utility, see [Updating firmware](#) on page 30.

Note: The xTalk utility can be used to either update drive firmware to the latest level or to capture drive dumps from a drive which may be experiencing problems.

Procedure 2: Inspecting a Cartridge for Damage

If the cartridge fails to load or unload properly, perform the following steps:

- 1 Check that the leader pin is attached and properly seated by opening the cartridge door and observing the pin's placement.
- 2 Inspect the cartridge case, the cartridge door, and the write-protect switch for damage.
- 3 Inspect the rear of the cartridge (the part that you load first into the tape load compartment) and ensure that there are no gaps in the seam of the cartridge case (see 1 in [Figure 11](#) on page 77 and 4 in [Figure 12](#) on page 79). If there are gaps, the leader pin may be dislodged.
- 4 Try loading or unloading another tape cartridge.
 - If it fails, contact your service representative for additional problem determination.
 - If it is successful, discard the cartridge that originally failed.

Note: If a damaged or mishandled cartridge is the problem, see [Handling Cartridges](#) on page 77 for proper instructions about handling media. It is possible that your other cartridges may also be damaged.

Note: If a cartridge is dropped and appears to externally be undamaged, there may still be internal damage that will not become obvious until an attempt is made to write or read data to/from the tape. If a tape is dropped, it is very likely the media inside the cartridge will have resultant edge damage that will cause later write/read problems. Keep close records of any dropped media and if write/read problems are seen in later use, remove the media from use and dispose of it.

Note: If your cartridge does not eject properly, contact your service representative.

Procedure 3: Checking SAS Host Connections

Check the host connections for your drive by following the steps below.

If your server is not communicating with the SAS drive, the problem may be with the SAS cable, the SAS host adapter or the SAS host adapter setup.

- 1 Check if the tape drive power is on.
- 2 Verify the SAS cable is connected properly to the server and to the tape drive.
- 3 Check whether the parameters for the SAS host adapter installation are correct.
- 4 Verify the SAS host adapter is supported by the tape drive.
- 5 Ensure there is a point-to-point connectivity between the server and the tape drive. SAS connectivity does not support multiple drive connections (daisy-chaining of devices).
- 6 Check the length of the SAS cable. It can not exceed 5.5m (18 ft).

Resolving Problems Reported by the Server

The procedure for fixing interface bus errors varies, depending on whether the error is consistent or intermittent, and on your configuration. The sections that follow describe how to fix an error.

Fixing SAS Bus Errors

- 1 Check if the tape drive power is on.
- 2 Verify the SAS cable is connected properly to the server and to the tape drive.
- 3 Replace SAS cable if it shows any signs of damage.

Resolving Media-Related Problems

To resolve problems that are related to media, the drive's firmware includes:

- Test Cartridge & Media diagnostic that verifies whether a suspect cartridge and its magnetic tape are acceptable for use.
- Statistical Analysis and Reporting System (SARS) to assist in isolating failures between media and hardware. To determine the cause of failure, SARS uses the cartridge performance history that is saved in the cartridge memory (CM) and the drive performance history that is kept in the drive's VPD (Vital Product Data) area in NVRAM. Any failures that SARS detects are reported as TapeAlert flags on the server (see Quantum LTO Ultrium Tape Drive SCSI Reference).

Caution: If you insert the Quantum LTO Ultrium Data Cartridge into another manufacturer's drive, the SARS data in the cartridge memory may become lost or invalid.

If you encounter a media-related problem, refer to [Function Code E: Test Cartridge & Media](#) on page 57.

Pre-Call Checklist

If you have questions or problems, go through this checklist before contacting Quantum Technical Support. Ensure that the total SAS cable length does not exceed 5.5m (18 ft). Perform the following steps before you place a call to Quantum Technical Support. Where instructions refer you to the web, visit <http://www.quantum.com/serviceandsupport>.

- 1 Perform a general checkup of the hardware and connections:
 - Verify that all cables are connected properly at both ends.
 - Before attaching the SAS cables, ensure that the connector does not contain bent or recessed pins.
 - Ensure that all retention screws for the SAS cable are securely tightened.
- 2 Verify that the drive's firmware is at the most recent level. To determine the latest release of firmware, visit the web. See [Updating firmware](#) on page 30 for instructions on downloading the latest firmware.
- 3 Verify that your device drivers are at the most recent level:
 - For Quantum device drivers, visit the web.
 - For the device drivers of independent software vendors (ISVs), visit the appropriate third-party web site.
- 4 Verify whether your hardware and software configuration is supported. To determine the latest supported attachments, visit the web.
- 5 Review "Frequently Asked Questions" and "Hints and Tips" on the web.
- 6 Run one of the following diagnostic methods:
 - Local diagnostic:
 - a Run [Function Code 1: Run Drive Diagnostics](#) on page 48 to determine whether the drive can properly load and unload cartridges, and read and write data. Optionally, you may run one of the following diagnostics:

- [Function Code E: Test Cartridge & Media](#) on page 57 to determine whether a suspect cartridge and its magnetic tape are acceptable.
 - [Function Code F: Write Performance Test](#) on page 58 to ensure that the drive can read from and write to tape.
 - [Function Code H: Test Head](#) on page 60 to ensure that the tape drive's head and tape-carriage mechanics work correctly.
 - [Function Code J: Fast Read/Write Test](#) on page 61 to ensure that the drive can read from and write to tape.
 - [Function Code L: Load/Unload Test](#) on page 62 to test the drive's ability to load and unload a tape cartridge.
- b** Use xTalk to run drive Health Check and other tests and to collect drive dumps.



Appendix A

Error Codes and Messages

If the drive detects a permanent error, it will display the error code on the SCD and flash the **Ready** light (**Ready** light will be Off).

- Make note of the SCD error code prior to removing a cartridge or clearing the SCD error code.
- If an error occurred with a cartridge in the drive, push the **Unload** button to eject the cartridge.
- To clear the SCD error code and power cycle the drive, press the **Unload** button for ten seconds. A drive dump will be created.

Caution: If the drive detects a permanent error and displays an error code other than **0**, it automatically performs a drive dump. If you force a drive dump, the existing dump will be overwritten and data will be lost. After you force a drive dump, do not turn off the power to the drive or you may lose the dump data.

Table 9 Error codes on the Single-character Display

Error Code	Cause and Action
0	<p>No error occurred and no action is required. This code displays when diagnostics have finished running and no error occurred.</p> <p>Note: The Single-character Display is blank during normal operation of the tape drive.</p>
1	<p>Temperature problem. The tape drive detected that the recommended operating temperature was exceeded. Perform one or more of the following actions:</p> <ul style="list-style-type: none"> • Ensure that the cooling fan is rotating and is quiet. If not, refer to your enclosure documentation. • Remove any blockage that prevents air from flowing freely through the tape drive. • Ensure that the operating temperature and airflow is within the specified range (see Specifications on page 20). <p>Clear the error code by power cycling the tape drive or placing the drive in Maintenance Mode. If the operating temperature and airflow are within the specified range, and the problem persists, replace the drive.</p>
2	<p>Power problem. The tape drive detected that the externally supplied power is outside the specified voltage limits (the tape drive is not operating). Perform the following action:</p> <ol style="list-style-type: none"> 1 Ensure that the power connector is properly seated. 2 Turn power off/on the tape drive to see if the problem repeats. 3 Replace the tape drive if the problem persists. <p>The error code clears when you place the tape drive in maintenance mode.</p>

Error Code	Cause and Action
3	<p>Firmware problem. The tape drive determined that a firmware error occurred. Perform the following action:</p> <ol style="list-style-type: none"> 1 Collect a drive dump from one of the following: <p>Note: Do not force a new dump; the tape drive has already created one.</p> <ul style="list-style-type: none"> • Server's host interface by using a device driver utility or system tool • Ultrium Tape Drive (to copy and read a drive dump, use Function Code 5: Copy Drive Dump on page 52), visit http://www.quantum.com/serviceandsupport 2 Power the tape drive off and on, then retry the operation that produced the error. 3 If the problem persists, download new firmware and retry the operation. 4 If the problem persists, send the drive dump that you collected in step 1 to your Quantum Support Center. <p>The error code clears when you place the tape drive in maintenance mode.</p>
4	<p>Firmware or hardware problem. The tape drive determined that a firmware or tape drive hardware failure occurred. Perform the following action:</p> <ol style="list-style-type: none"> 1 Collect a drive dump from one of the following: <p>Note: Do not force a new dump; one already exists.</p> <ul style="list-style-type: none"> • Server's host interface by using a device driver utility or system tool (for instructions about reading a drive dump from tape, visit the Web at http://www.quantum.com/serviceandsupport) • Ultrium Tape Drive (to copy and read a drive dump, use Function Code 5: Copy Drive Dump on page 52) 2 Power the tape drive off and on, then retry the operation that produced the error. The error code clears when you place the tape drive in maintenance mode. 3 If the problem persists, download new firmware and retry the operation; if new firmware is not available, replace the drive.
5	<p>Tape drive hardware problem. The drive determined that a tape path or read/write error occurred. To prevent damage to the drive or tape, the tape drive will not allow you to insert a cartridge if the current cartridge was successfully ejected. The error code may clear when you cycle power to the tape drive or place it in maintenance mode. If the problem persists, replace the drive.</p> <p>Note: Copy the drive dump to flash memory before returning the drive. For instructions, refer to Function Code 5: Copy Drive Dump on page 52.</p>

Error Code	Cause and Action
6	<p>Tape drive or media error. The tape drive determined that an error occurred, but it cannot isolate the error to faulty hardware or to the tape cartridge. Ensure the tape cartridge is the correct media type:</p> <ul style="list-style-type: none"> • Ultrium 1, 2, 3, 4, 5 and 6 cartridges are not supported in the Ultrium 8 tape drive. • Drive will not accept an expired Cleaning Cartridge. • Drive will not accept a WORM cartridge when running diagnostic tests in Maintenance Mode. • Drive will not write over existing datasets on a WORM cartridge. Ensure you are appending datasets on WORM media rather than attempting to write over existing datasets. <p>If the tape cartridge is the correct media type, perform the following action:</p>
6	<p>For Problems with Writing Data:</p> <p>If the problem occurred while the tape drive was writing data to the tape, retry the operation with a different cartridge:</p> <ul style="list-style-type: none"> • If the operation succeeds, the original cartridge was defective. Copy data from the defective cartridge and discard it. • If the operation fails and another tape drive is available, insert the cartridge into the other unit and retry the operation. <ul style="list-style-type: none"> • If the operation fails, discard the defective cartridge. • If the operation succeeds, insert a scratch data cartridge into the first unit and run Function Code 1: Run Drive Diagnostics on page 48. • If the diagnostics fail, replace the tape drive. • If the diagnostics succeed, the error was temporary. • If the operation fails and another tape drive is not available, insert a scratch data cartridge into the unit and run Function Code 1: Run Drive Diagnostics on page 48. <ul style="list-style-type: none"> • If the diagnostics fail, replace the tape drive. • If the diagnostics succeed, discard the cartridge. <p>If the problem occurs with multiple tape cartridges, run Function Code 1: Run Drive Diagnostics on page 48:</p> <ul style="list-style-type: none"> • If the diagnostics fail, replace the tape drive. • If the diagnostics succeed, run Function Code H: Test Head on page 60. <ul style="list-style-type: none"> • – If the diagnostic fails, replace the tape drive. • – If the diagnostic succeeds, replace the cartridges that caused the problem. <p>The error code clears when you remove the tape cartridge or place the tape drive in maintenance mode.</p>

Error Code	Cause and Action
6	<p>For Problems with Reading Data:</p> <p>If the problem occurred while the tape drive was reading data from the tape, perform one of the following procedures:</p> <ul style="list-style-type: none"> • If another tape drive is available, insert the cartridge into the other unit and retry the operation: <ul style="list-style-type: none"> • If the operation fails, discard the defective cartridge. • If the operation succeeds, insert a scratch data cartridge into the first unit and run Function Code 1: Run Drive Diagnostics on page 48: • If the diagnostic fails, replace the tape drive. • If the diagnostic succeeds, the error was temporary. • If another tape drive is not available, insert a scratch data cartridge into the unit and run Function Code 1: Run Drive Diagnostics on page 48: <ul style="list-style-type: none"> • If the diagnostic fails, replace the tape drive. • If the diagnostic succeeds, discard the cartridge. <p>If the problem occurs with multiple tape cartridges, run Function Code 1: Run Drive Diagnostics on page 48:</p> <ul style="list-style-type: none"> • If the diagnostic fails, replace the tape drive. • If the diagnostic succeeds, run Function Code H: Test Head on page 60. <ul style="list-style-type: none"> • If the diagnostic fails, replace the tape drive. • If the diagnostic succeeds, replace the cartridges that caused the problem. <p>The error code clears when you remove the tape cartridge or place the tape drive in maintenance mode.</p>

Error Code	Cause and Action
7	<p>Media error. The tape drive determined an error occurred because of a faulty tape cartridge or an invalid tape cartridge. Ensure the tape cartridge is the correct media type:</p> <ul style="list-style-type: none"> • Ultrium 1, 2, 3, 4, 5 and 6 cartridges are not supported in the Ultrium 8 tape drive. • Drive will not accept an expired Cleaning Cartridge. • Drive will not accept a WORM cartridge when running diagnostic tests in Maintenance Mode. • Drive will not accept an FUP tape unless the drive is performing Function Code 8: Unmake FUP Tape on page 55. • Drive will not write over existing datasets on a WORM cartridge. Ensure you are appending datasets on WORM media rather than attempting to write over existing datasets. • Drive will not Create an FUP Tape (Maintenance Mode, Function Code 3) with a cartridge that is already an FUP tape. Use another cartridge or execute Maintenance Mode Function Code 8: Unmake FUP Tape. • Drive will not Unmake FUP Tape (Maintenance Code 8) with a cartridge that is not an FUP tape. <p>If the tape cartridge is the correct media type, try another tape cartridge. If the problem occurs with multiple tape cartridges, use the following procedure:</p> <ol style="list-style-type: none"> 1 If possible, run the tape cartridge in a different tape drive. If the operation in the other unit fails and 6 or 7 displays, replace the media. If the operation succeeds, run Function Code E: Test Cartridge & Media on page 57. <p>Caution: When you run the Test Cartridge & Media diagnostic, data on the suspect tape is overwritten. Use only a scratch data cartridge to run the test.</p> <ul style="list-style-type: none"> • If the diagnostic fails, replace the media. • If the diagnostic succeeds, clean the drive head (see Cleaning the Drive Head on page 43) and run Function Code 1: Run Drive Diagnostics on page 48. <ul style="list-style-type: none"> • If the drive diagnostic fails, replace the drive. • If the drive diagnostic succeeds, perform the operation that produced the initial media error. <p>The error code clears when you remove the tape cartridge or place the tape drive in maintenance mode.</p>

Error Code	Cause and Action
8	<p>Interface problem. The tape drive determined that a failure occurred in the tape drive's hardware or in the host bus. See Chapter 6, Troubleshooting. If 8 was displayed while running Function Code 6: Run Host Interface Wrap Test on page 53:</p> <ol style="list-style-type: none"> 1 Verify the correct interface wrap tool was attached during the test. The test will fail if the correct interface wrap tool is not attached. 2 If the correct interface wrap tool was attached during the test, replace the drive. The error code clears when you place the tape drive in maintenance mode.
9	<p>Tape drive or RS-422 error. The tape drive determined that a failure occurred in the tape drive's hardware or in the RS-422 connection. See Function Code 7: Run RS-422 Wrap Test on page 54 to isolate the problem to the drive. The error code clears when you place the tape drive in maintenance mode.</p>

Error Code	Cause and Action
A	<p>Degraded operation. The tape drive determined that a problem occurred which degraded the operation of the tape drive, but it did not restrict continued use. If the problem persists, determine whether the problem is with the drive or the media.</p> <p>Note: The drive is usable, though the Single-character Display continues to indicate an error and the Fault light flashes. The error code may clear when you cycle power to the tape drive or place it in maintenance mode.</p> <p>To determine if the problem is with the drive hardware, or the tape media, perform the following procedures:</p> <ol style="list-style-type: none"> 1 If possible, run the tape cartridge in a different drive. If the operation in the other drive fails and 6 or 7 displays, replace the media. If the operation succeeds, run the Test Cartridge & Media diagnostic (see Function Code E: Test Cartridge & Media on page 57). 2 If the Test Cartridge & Media diagnostic fails, replace the media. If it runs successfully, clean the failing drive and run the drive diagnostics (see Cleaning the Drive Head on page 43 and Function Code 1: Run Drive Diagnostics on page 48). Once you begin this test, the diagnostic begins the loop sequence. Time the first loop by pressing the Unload button once to stop the diagnostic after the completion of the first loop, then record the time it takes for the test to complete. Compare the recorded time with the "Approximate Run Time" above. If the test runs successfully but the execution time is significantly longer than the "Approximate Run Time", run Function Code F: Write Performance Test on page 58. If the Write Performance Test fails, replace the media and exit maintenance mode. If the drive diagnostics run successfully, perform the operation that produced the initial drive error. 3 If the problem persists replace the drive. <p>If it is not possible to run the tape cartridge in a different drive, perform the following procedures:</p> <ol style="list-style-type: none"> 1 Clean the failing drive and run the drive diagnostics (see Cleaning the Drive Head on page 43 and Function Code 1: Run Drive Diagnostics on page 48). 2 If the Test Cartridge & Media diagnostic fails, replace the media. If it runs successfully, perform the operation that produced the initial drive error. 3 If the problem persists replace the drive.
C	<p>The tape drive needs to be cleaned. Clean the tape drive. See Cleaning the Drive Head on page 43.</p> <p>The error code clears when you clean the tape drive or place it in maintenance mode.</p>
d	<p>Fiber AL_PA conflict. Two drives on fiber loop have the same AL_PA. Modify the tape drive AL_PA to eliminate the conflict. NOT SUPPORTED ON THIS DRIVE.</p>

Error Code	Cause and Action
e	<p>Encryption Error. Displayed when the drive detects an error associated with a encryption operation. If the problem occurred while the tape drive was writing data to, or reading data from, tape:</p> <ol style="list-style-type: none"> 1 Check the host application to ensure the host application is providing the correct encryption key. <ul style="list-style-type: none"> • Refer to the Quantum LTO Ultrium Tape Drive SCSI Reference documentation for the Sense Data returned for an encryption operation. • Retry the encryption operation after the host application problems have been resolved. 2 Check the operation of the tape drive by resetting the drive and running POST. <ul style="list-style-type: none"> • Refer to the error code displayed on the SCD if the drive reset and POST fails. • Retry the encryption operation if the drive reset and POST complete without errors. 3 Check the media. <ul style="list-style-type: none"> • Ensure the correct media is being used. Data encryption is supported with LTO Ultrium 5 and higher Data Cartridges only. • Retry the encryption operation with the tape cartridge in another encryption enabled drive. Replace the media if the problem repeats with the same tape cartridge in multiple drives. <p>If the problem occurred while the tape drive was running POST or diagnostics, replace the drive.</p> <p>The error code clears with the first attempted write/read after the encryption key is changed, or when the drive is placed in maintenance mode.</p>
E	Fiber Port offline. NOT SUPPORTED ON THIS DRIVE.
F	Fiber Channel Error. NOT SUPPORTED ON THIS DRIVE.
J	Incompatible media. The tape drive detected an unsupported cartridge was loaded or the cartridge loaded has an incompatible format.
P	Write operation to a write protected cartridge was attempted (includes any attempt to overwrite a WORM protected tape). Ensure that the tape cartridge is the correct media type. If the tape cartridge is the correct media type, check the write-protect switch on the cartridge. The drive does not write to a write-protected cartridge. The error code clears when you remove the tape cartridge or place the tape drive in Maintenance mode.



Appendix B

Tape Alert Flags

TapeAlert is a patented technology and standard of the American National Standards Institute (ANSI) that defines conditions and problems that are experienced by tape drives. The technology enables a server to read TapeAlert flags from a tape drive through the host interface. The server reads the flags from Log Sense Page 0x2E. Refer to the Quantum LTO Ultrium Tape Drive SCSI Reference for the list of TapeAlert flags that are supported by this tape drive.



Glossary

This glossary defines the special terms, abbreviations, and acronyms that are used in this publication. If you do not find the term you are looking for, refer to the index or to the Dictionary of Computing, 1994.

Numbers

2.5:1 compression The relationship between the quantity of data that can be stored with compression as compared to the quantity of data that can be stored without compression. In 2.5:1 compression, two and a half times as much data can be stored with compression as can be stored without compression.

A

ac Alternating current.

access method A technique for moving data between main storage and input or output devices.

adapter card A circuit board that adds function to a computer.

adj Adjustment.

alphanumeric Pertaining to a character set that contains letters, numerals, and usually other characters, such as punctuation marks.

alter To change.

ambient temperature The temperature of air or other media in a designated area, particularly the area surrounding equipment.

ampere (A) A unit of measure for electric current that is equivalent to a flow of one coulomb per second, or to the current produced by one volt applied across a resistance of one ohm.

ANSI American National Standards Institute.

archive To collect and store files in a designated place.

ASCII American National Standard Code for Information Interchange. A 7 bit coded character set (8 bits including parity check) that consists of control characters and graphic characters.

assigning a device The establishing of the relationship of a device to a running task, process, job, or program.

assignment The naming of a specific device to perform a function.

asynchronous Pertaining to two or more processes that do not depend upon the occurrence of specific events such as common timing signals.

attention (notice) A word for calling attention to the possibility of danger to a program, device, or system, or to data. Contrast with caution and danger.

ATTN Attention.

B

backup To make additional copies of documents or software for safekeeping.

bar code A code representing characters by sets of parallel bars of varying thickness and separation which are read optically by transverse scanning.

bar code label Paper bearing a bar code and having an adhesive backing. The bar code label must be affixed to a tape cartridge to enable the library to identify the cartridge and its volume serial number.

bar code reader A laser device specialized for scanning and reading bar codes and converting them into either the ASCII or EBCDIC digital character code.

bezel Decorative and safety cover.

bicolored Having two colors.

bit Either of the digits 0 or 1 when used in the binary numbering system.

BOM (bill of materials) A list of specific types and amounts of direct materials expected to be used to produce a given job or quantity of output.

browser A client program that initiates requests to a Web server and displays the information that the server returns.

buffer A routine or storage used to compensate for a difference in rate of flow of data or time of occurrence of events, when transferring data from one device to another.

bus A facility for transferring data between several devices located between two end points, only one device being able to transmit at a given moment.

byte A string consisting of a certain number of bits (usually 8) that are treated as a unit and represent a character. A fundamental data unit.

C

capacity The amount of data that can be contained on storage media and expressed in bytes of data.

cartridge manual rewind tool A device that can be fitted into the reel of a cartridge and used to rewind tape into or out of the cartridge.

cartridge storage slot Individual slot located within a magazine that is used to house tape cartridges.

caution (notice) A word to call attention to possible personal harm to people. Contrast with attention and danger.

CE Customer engineer; field engineer; service representative.

centimeter (cm) One one-hundredth of a meter (0.01 m).
Approximately 0.39 inch.

channel command An instruction that directs a data channel, control unit, or device to perform an operation or set of operations.

char Character.

CHK Check.

- cleaning cartridge** A tape cartridge that is used to clean the heads of a tape drive. Contrast with data cartridge.
- command** A control signal that initiates an action or the start of a sequence of actions.
- compact disc (CD)** A disc, usually 4.75 inches in diameter, from which data is read optically by means of a laser.
- compression** The process of eliminating gaps, empty fields, redundancies, and unnecessary data to shorten the length of records or blocks.
- concurrent** Refers to diagnostic procedures that can be run on one control unit while the rest of the subsystem remains available for customer applications.
- contingent connection** A connection between a channel path and a drive caused when a unit check occurs during an I/O operation.
- controller** A device that provides the interface between a system and one or more tape drives.
- CP** Circuit protector.
- ctrl** Control.
- CU** Control unit.

D

- danger (notice)** A word to call attention to possible lethal harm to people. Contrast with attention and caution.
- data** Any representations such as characters or analog quantities to which meaning is or might be assigned.
- data buffer** The storage buffer in the control unit. This buffer is used to increase the data transfer rate between the control unit and the channel.
- data cartridge** A tape cartridge dedicated to storing data. Contrast with cleaning cartridge.
- data check** A synchronous or asynchronous indication of a condition caused by invalid data or incorrect positioning of data.
- dc** Direct current.

degauss To make a magnetic tape nonmagnetic by means of electrical coils carrying currents that neutralize the magnetism of the tape.

degausser A device that makes magnetic tape nonmagnetic.

degradation A decrease in quality of output or throughput or an increase in machine error rate.

degraded Decreased in quality of output or throughput or increased machine error rate.

deserialize To change from serial-by-bit to parallel-by-byte.

detented A part being held in position with a catch or lever.

device Any hardware component or peripheral, such as a tape drive or tape library, that can receive and send data.

device driver A file that contains the code needed to use an attached device.

DIAG Diagnostic section of maintenance information manual.

differential See High Voltage Differential (HVD).

direct access storage A storage device in which the access time is independent of the location of the data.

download To transfer programs or data from a computer to a connected device, typically a personal computer.

DRAM Dynamic random-access memory.

drive, magnetic tape A mechanism for moving magnetic tape and controlling its movement.

DSE Data security erase.

DSP Digital signal processor.

E

EBCDIC Extended binary-coded decimal interchange code.

EC Edge connector. Engineering change.

ECC Error correction code.

EEPROM Electrically erasable programmable read-only memory.

EIA Electronics Industries Association.

- EIA unit** A unit of measure, established by the Electronic Industries Association, equal to 44.45 millimeters (1.75 inches).
- eject** To remove or force out from within.
- electronic mail** Correspondence in the form of messages transmitted between user terminals over a computer network.
- e-mail** See electronic mail.
- EPO** Emergency power off.
- EPROM** Erasable programmable read only memory.
- EQC (Equipment check)** An asynchronous indication of a malfunction.
- Error log** A dataset or file in a product or system where error information is stored for later access.
- ESD** Electrostatic discharge.

F

- fault symptom code (FSC)** A hexadecimal code generated by the drive or the control unit microcode in response to a detected subsystem error.
- FC** Feature code.
- FCC** Federal communications commission.
- FE** Field engineer, customer engineer, or service representative.
- field replaceable unit (FRU)** An assembly that is replaced in its entirety when any one of its components fails.
- file** A named set of records stored or processed as a unit. Also referred to as a dataset.
- file protection** The processes and procedures established in an information system that are designed to inhibit unauthorized access to, contamination of, or deletion of a file.
- file transfer protocol (FTP)** In the Internet suite of protocols, an application layer protocol that uses TCP and Telnet services to transfer bulk-data files between machines or hosts.
- firmware** Proprietary code that is usually delivered as microcode as part of an operating system. Firmware is more efficient than software loaded from an alterable medium and more adaptable

to change than pure hardware circuitry. An example of firmware is the Basic Input/Output System (BIOS) in read-only memory (ROM) on a PC motherboard.

FLASH EEPROM An electrically erasable programmable read-only memory (EEPROM) that can be updated.

FUP firmware update procedure.

format The arrangement or layout of data on a data medium.

formatter Part of a magnetic tape subsystem that performs data conversion, speed matching, encoding, first level error recovery, and interfaces to one or more tape drives.

FP File protect.

frayed Damaged as if by an abrasive substance.

FRU Field replaceable unit.

FSC Fault symptom code.

FSI Fault symptom index.

functional microcode Microcode that is resident in the machine during normal customer operation.

G

g Gram.

GB gigabyte.

GBIC Gigabit Interface Converter.

Gbi gigabit

gigabit (Gbit) 1 000 000 000 bits.

gigabyte (GB) 1 000 000 000 bytes.

Gigabit Interface Converter (GBIC) Converts copper interface to optic interface.

gnd Ground.

H

hertz (Hz) Unit of frequency. One hertz equals one cycle per second.

hex Hexadecimal.

High Voltage Differential (HVD) A logic signaling system that enables data communication between a supported host and the device. HVD signaling uses a paired plus and minus signal level to reduce the effects of noise on the SCSI bus. Any noise injected into the signal is present in both a plus and minus state, and is thereby canceled. Synonymous with differential.

Hz Hertz (cycles per second).

I

identifier (ID) (1) In programming languages, a lexical unit that names a language object; for example, the names of variables, arrays, records, labels, or procedures. An identifier usually consists of a letter optionally followed by letters, digits, or other characters. (2) One or more characters used to identify or name data element and possibly to indicate certain properties of that data element. (3) A sequence of bits or characters that identifies a program, device, or system to another program, device, or system.

IML (Initial microprogram load) The action of loading a microprogram from an external storage to writable control storage.

initiator The component that executes a command. The initiator can be the host system or the tape control unit.

INST Installation.

interface A shared boundary. An interface might be a hardware component to link two devices or it might be a portion of storage or registers accessed by two or more computer programs.

interposer The part used to convert a 68-pin connector to a 50-pin D-shell connector.

intervention required Manual action is needed.

INTRO Introduction.

I/O Input/output.

IOP Input/output processor.

IPL Initial program load.

ITST Idle-time self-test.

K

kilogram (kg) One thousand grams (approximately 2.2 pounds).

km kilometer. 1000 Meters, Approximately 5/8 mile.

L

LAN (Local area network) A computer network within a limited area.

LED Light-emitting diode.

Linear Tape-Open (LTO) A type of tape storage technology developed by the Quantum Corporation, Hewlett-Packard, and Certance. LTO technology is an “open format” technology, which means that its users will have multiple sources of product and media. The “open” nature of LTO technology enables compatibility between different vendors’ offerings by ensuring that vendors comply with verification standards. The LTO technology is implemented in two formats: the Accelis format focuses on fast access; the Ultrium format focuses on high capacity. The Ultrium format is the preferred format when capacity (rather than fast access) is the key storage consideration. An Ultrium cartridge has a compressed data capacity of up to 800 GB (2:1 compression) and a native data capacity of up to 400 GB.

liquid crystal display (LCD) A low-power display technology used in computers and other I/O devices.

loadable Having the ability to be loaded.

LTO cartridge memory (LTO-CM) Within each LTO Ultrium data cartridge, an embedded electronics and interface module that can store and retrieve a cartridge’s historical usage and other information.

M

magnetic tape A tape with a magnetic surface layer on which data can be stored by magnetic recording.

MAP Maintenance analysis procedure.

mask A pattern of characters that controls the retention or elimination of portions of another pattern of characters. To use a pattern of characters to control the retention or elimination of portions of another pattern of characters.

- master file** A file used as an authority in a given job and that is relatively permanent, even though its contents may change. Synonymous with main file.
- MB** Mega Byte (usually expressed as data rate in MB/s or MB/second).
- media capacity** The amount of data that can be contained on a storage medium, expressed in bytes of data.
- media-type identifier** Pertaining to the bar code on the bar code label of the Quantum Ultrium Tape Cartridge, a 2-character code, L1, that represents information about the cartridge. L identifies the cartridge as one that can be read by devices which incorporate LTO technology; 1 indicates that it is the first generation of its type.
- mega** One million of.
- meter** In the Metric System, the basic unit of length; equal to approximately 39.37 inches.
- micro** One millionth of.
- microcode** (1) One or more micro instructions. (2) A code, representing the instructions of an instruction set, implemented in a part of storage that is not program-addressable. (3) To design, write, and test one or more micro instructions. (4) See also microprogram.
- microdiagnostic routine** A program that runs under the control of a supervisor, usually to identify field replaceable units.
- microdiagnostic utility** A program that is run by the customer engineer to test the machine.
- microinstruction** A basic or elementary machine instruction.
- microprogram** A group of microinstructions that when executed performs a preplanned function. The term microprogram represents a dynamic arrangement or selection of one or more groups of microinstructions for execution to perform a particular function. The term microcode represents microinstructions used in a product as an alternative to hard-wired circuitry to implement certain functions of a processor or other system component.
- MIM** Media information message.
- mm** Millimeter.

modifier That which changes the meaning.

mount a device To assign an I/O device with a request to the operator.

MP Microprocessor.

ms Millisecond.

MSG Message.

multipath Pertaining to using more than one path.

N

node In a network, a point at which one or more functional units connect channels or data circuits.

NVS (Nonvolatile storage) A storage device whose contents are not lost when power is cut off.

O

oersted The unit of magnetic field strength in the unrationalized centimeter-gram-second (cgs) electromagnetic system. The oersted is the magnetic field strength in the interior of an elongated, uniformly wound solenoid that is excited with a linear current density in its winding of one abampere per 4 π centimeters of axial length.

offline Pertaining to the operation of a functional unit without the continual control of a computer. Contrast with online.

online Pertaining to the operation of a functional unit that is under the continual control of a computer. Contrast with offline.

OPER Operation.

ov Over voltage.

overrun Loss of data because a receiving device is unable to accept data at the rate it is transmitted.

P

parameter A variable that is given a constant value for a specified application and that may denote the application.

p bit Parity bit.

PC Parity check.

- PCC** Power control compartment.
- PE** Parity error. Product engineer.
- PM** Preventive maintenance.
- POR** Power-on reset.
- port** A physical connection for communication between the 3590 and the host processor. The 3590 has two SCSI ports.
- Portable Document Format (PDF)** A standard specified by Adobe Systems, Incorporated, for the electronic distribution of documents. PDF files are compact, can be distributed globally (via e-mail, the Web, Intranet, or CD-ROM), and can be viewed with the Acrobat Reader, which is software from Adobe Systems that can be downloaded at no cost from the Adobe Systems home page.
- PROM** Programmable read only memory.

R

- rack** A unit that houses the components of a storage subsystem, such as the library.
- rackmount kit** A packaged collection of articles used to install the rack mounted version of the library.
- RAM (Random access memory)** A storage device into which data is entered and from which data is retrieved in a non-sequential manner.
- record** A collection of related data or words, treated as a unit.
- recording density** The number of bits in a single linear track measured per unit of length of the recording medium.
- recoverable error** An error condition that allows continued execution of a program.
- ref** Reference.
- reg** Register.
- Retention** The process or function of tightening the tape onto the cartridge, if it is sensed that the tape has a loose wrap on the cartridge.
- RPQ** Request for price quotation.

R/W Read/write.

S

SAC (Service Action Code) Code developed to indicate possible FRU or FRU's to replace to repair the hardware.

SAS Serial attached SCSI interface.

scratch cartridge A data cartridge that contains no useful data, but can be written to with new data.

segment A part.

sel Select.

serialize To change from parallel-by-byte to serial-by-bit.

serializer A device that converts a space distribution of simultaneous states representing data into a corresponding time sequence of states.

servo, servos An adjective for use in qualifying some part or aspect of a servomechanism.

servomechanism A feedback control system in which at least one of the system signals represents mechanical motion.

Small Computer Systems Interface (SCSI) A standard used by computer manufacturers for attaching peripheral devices (such as tape drives, hard disks, CD-ROM players, printers, and scanners) to computers (servers). Pronounced "scuzzy". Variations of the SCSI interface provide for faster data transmission rates than standard serial and parallel ports (up to 160 megabytes per second). The variations include:

- Fast/Wide SCSI: Uses a 16-bit bus, and supports data rates of up to 20 MBps.

- SCSI-1: Uses an 8-bit bus, and supports data rates of 4 MBps.

- SCSI-2: Same as SCSI-1, but uses a 50-pin connector instead of a 25-pin connector, and supports multiple devices.

- Ultra SCSI: Uses an 8- or 16-bit bus, and supports data rates of 20 or 40 MBps.

- Ultra2 SCSI: Uses an 8- or 16-bit bus and supports data rates of 40 or 80 MBps.

- Ultra3 SCSI: Uses a 16-bit bus and supports data rates of 80 or 160 MBps.

- Ultra160 SCSI: Uses a 16-bit bus and supports data rates of 80 or 160 MBps.

special feature A feature that can be ordered to enhance the capability, storage capacity, or performance of a product, but is not essential for its basic work.

SRAM Static random access memory.

SS Status store.

standard feature The significant design elements of a product that are included as part of the fundamental product.

START Start maintenance.

subsystem A secondary or subordinate system, usually capable of operating independently of, or asynchronously with, a controlling system.

sync (Synchronous, synchronize) Occurring with a regular or predictable time relationship.

T

tachometer, tach A device that emits pulses that are used to measure/check speed or distance.

tape cartridge A container holding magnetic tape that can be processed without separating it from the container.

tape void An area in the tape in which no signal can be detected.

TCP/IP Transmission Control Protocol/Internet Protocol.

TCU Tape control unit.

thread/load operation A procedure that places tape along the tape path.

U

UART Universal asynchronous receiver/transmitter.

unload Prepare the tape cartridge for removal from the drive.

utility programs A computer program in general support of the processes of a computer; for instance, a diagnostic program.

uv Under voltage.

V

VOLSER Volume serial number.

volume A certain portion of data, together with its data carrier, that can be handled conveniently as a unit.

VPD (Vital product data) The information contained within the tape drive that requires nonvolatile storage used by functional areas of the drive, and information required for manufacturing, and engineering.

W

word A character string that is convenient for some purpose to consider as an entity.

X

XR External register.

XRA External register address register.

