

## Installing the Desktop Tape Drive

Quantum LTO Ultrium tape solutions leverage LTO technology and Quantum-exclusive features to provide the most reliable and affordable tape data protection to medium and large businesses.

Quantum LTO drives are the most reliable Ultrium drives on the market, delivering reliability features only available from Quantum, including multi-speed transfer to automatically match the host's data transfer rate and Dynamic Powerdown to protect the drive and media in the event of power loss. Combined with SmartVerify to concurrently verify all data written to the tape, these features make Quantum LTO drives a sound investment and a complete data protection solution.

NOTE: This procedure provides step-by-step instructions for installing a desktop LTO-2 Half-Height drive. Please refer to the other side for instructions

Copyright © 2005 by Quantum Corporation. All Rights Reserved.  
Quantum and the Quantum logo are trademarks of Quantum Corporation. Other product names are trademarks or registered trademarks of their respective owners. Quantum reserves the right to change, without notice, product offerings or specifications. No part of this publication may be reproduced in any form without written permission from Quantum Corporation.  
Part number: 10011345-101 May 2005



LTO-2 Half-Height Tape Drive

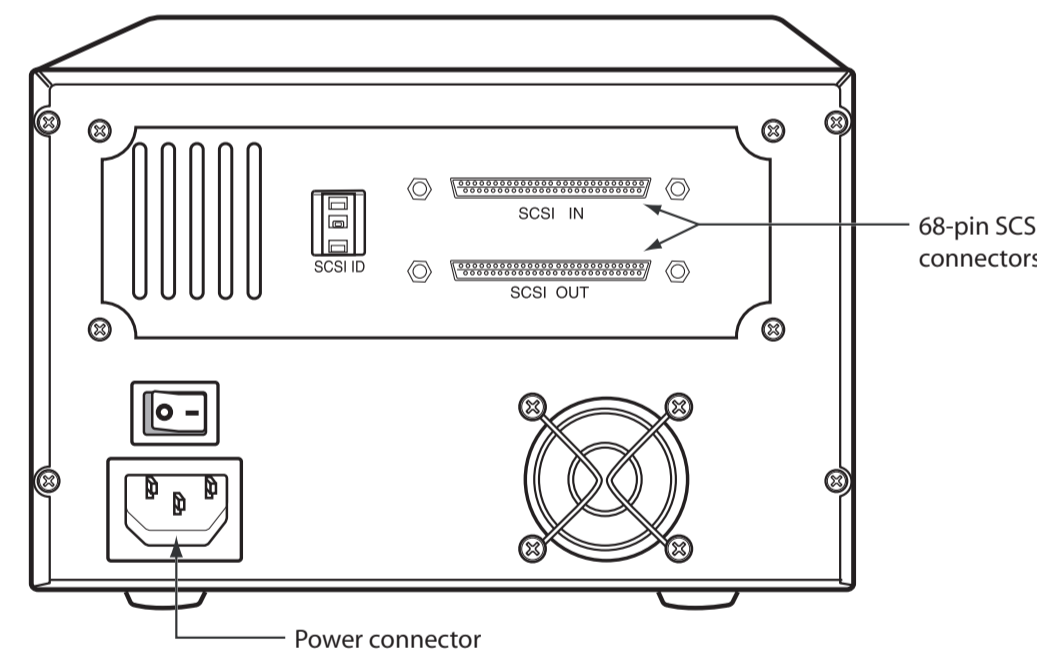

Back of LTO-2 Half-Height Tape Drive

Figure 1. Two SCSI Termination Examples for the Desktop LTO-2 Half-Height Tape Drive

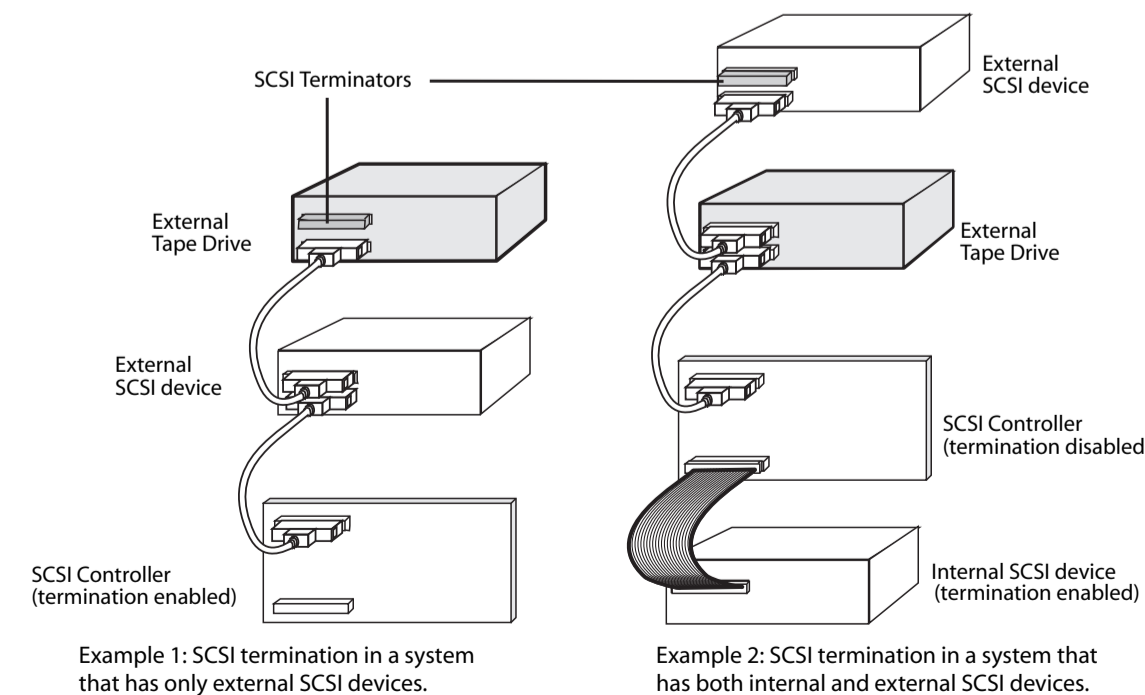

Before installing the drive, read the following instructions:

- Install LVD drives only in an LVD environment. Do not mix HVD and LVD devices on the same SCSI bus.
- Due to the speed of the LTO-2 drive, it is recommended that a maximum of one LTO-2 drive be connected to one host SCSI adapter.

1. Unpack the contents of your drive package. If any item is damaged, please contact your place of purchase immediately.
2. The Desktop tape drive is shipped with a default SCSI ID of 6. If another SCSI device in the SCSI chain is using this ID, either use the push-button switch on the back of the drive to change the drive's SCSI ID or assign a unique SCSI ID to the other SCSI device. Before changing the SCSI ID on the tape drive, turn off the tape drive. The change takes effect when the drive is turned on again. Avoid setting the drive ID to 7.
3. Turn off all power to the drive and the computer.
4. Attach the SCSI interface cable to either of the two 68-pin SCSI interface connectors on the back of the drive.
5. If the Desktop LTO-2 Half-Height drive is the last or only device in a SCSI chain, install a 68-pin LVD terminating plug on the unused SCSI connector. Figure 1 shows two examples.
6. Attach the power cord securely to the power connector on the back of the Desktop LTO-2 Half-Height drive. Connect the other end of the power cable to a working AC outlet.
7. Register your tape drive through our Web site at [www.quantum.com/registration](http://www.quantum.com/registration).

## Installing the Internal Tape Drive

Observe the following guidelines:

- Handle the drive by the sides rather than by the top cover to reduce the risk of dropping the drive or damaging it during installation.
- Internal drives contain some exposed components that are sensitive to static electricity. To reduce the possibility of damage from static discharge, the drives are shipped in a protective antistatic bag. Do not remove the drive from the antistatic bag until you are ready to install it.
- Before you remove the drive from the antistatic bag, touch a metal or grounded surface to discharge any static electricity buildup from your body.
- Always lay the drive either on top of the antistatic bag or place it inside the bag to reduce the chance of damage from static discharge.
- Install LVD drives only in an LVD environment. Do not mix HVD and LVD devices on the same SCSI bus.
- Due to the speed of the LTO-2 Half-Height drive, it is recommended that a maximum of one LTO-2 drive be connected to one host SCSI adapter.

NOTE: This procedure provides step-by-step instructions for installing an internal LTO-2 Half-Height drive. Please refer to the other side for instructions on installing a desktop version of the drive. Please read the instructions completely before beginning the installation process.

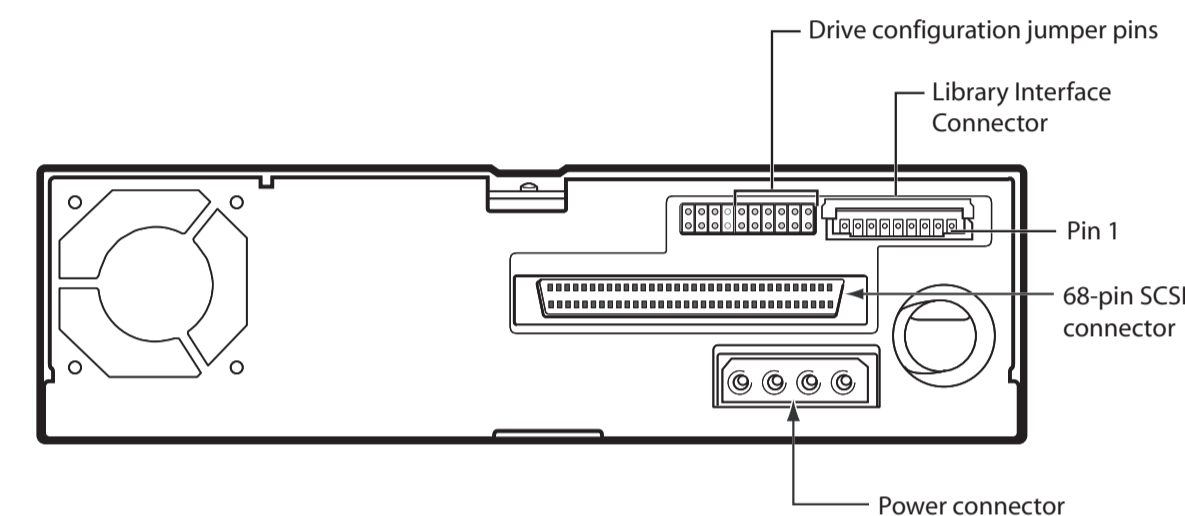
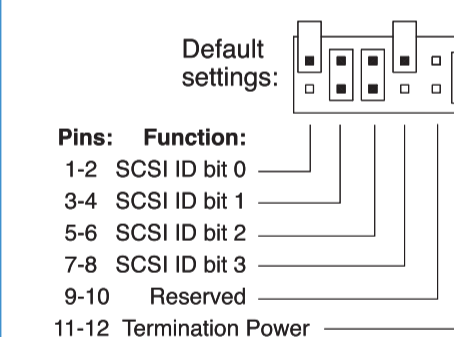

Figure 1. Back of Internal LTO-2 Half-Height Drive

Drive Configuration Jumper Pins



Jumper Settings:

SCSI ID=0	SCSI ID=8
SCSI ID=1	SCSI ID=9
SCSI ID=2	SCSI ID=10
SCSI ID=3	SCSI ID=11
SCSI ID=4	SCSI ID=12
SCSI ID=5	SCSI ID=13
SCSI ID=6	SCSI ID=14
SCSI ID=7	SCSI ID=15
	Term. power

Figure 2. Internal LTO-2 Half-Height Drive Jumper Settings

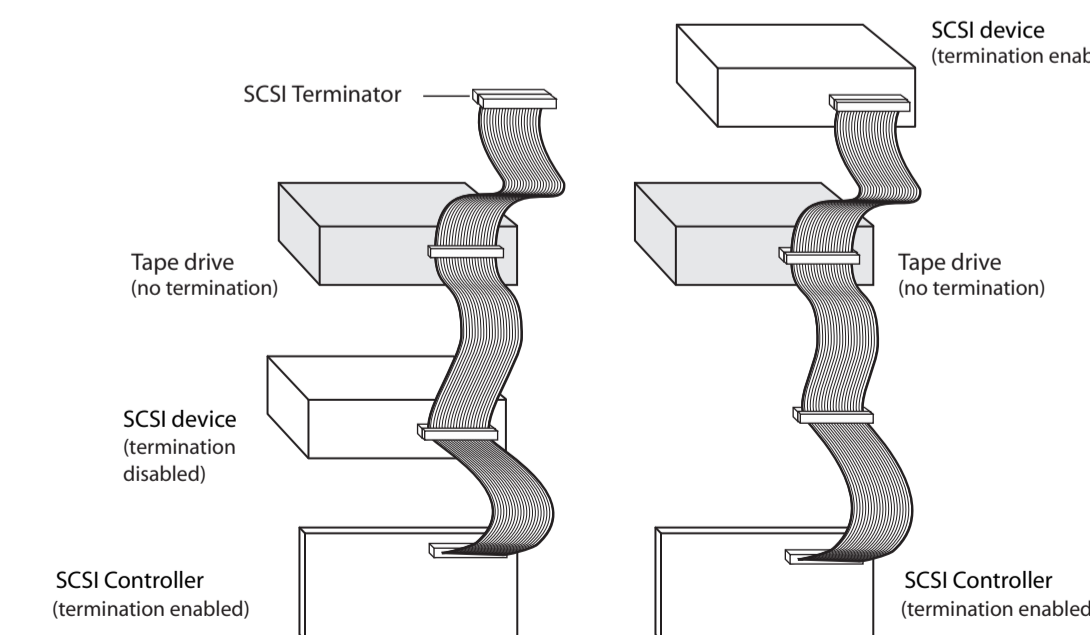

Figure 3. Two SCSI Termination Examples for the Internal Drive

1. Unpack the contents of your drive package. If any item is damaged, please contact your place of purchase immediately.
2. Shut down the host computer and disconnect the AC power cord.
3. The drive's default SCSI ID is 6 and terminator power is disabled.
  - To change the SCSI ID, refer to Figure 2.
  - To enable terminator power, place a jumper across pins 11 and 12.
4. Select an available 5.25-inch, half-height mounting bay for the drive. The drive can be mounted either horizontally or vertically.
  - For vertical mounting: the side of the drive should be within 5 degrees of horizontal.
  - For horizontal mounting: the base of the drive must be within 15 degrees of horizontal and the drive must be right-side up.
5. Secure the drive using two M3.0 X 3 metric screws on each side of the drive. Do not use screws longer than 3 mm or you may damage the drive.
6. With all power to the computer and drive turned off, attach the SCSI interface cable to the 68-pin SCSI interface connector on the back of the drive (see Figure 1).
7. By default, the internal LTO-2 Half-Height drive does not provide SCSI termination. If you use this default setting, place a SCSI bus terminator or a SCSI device with termination enabled at the end of the SCSI chain. Figure 3 shows two examples. Note that the drive provides terminator power if a jumper is placed on the termination power jumper pins (see step 4 and Figure 2).
8. Attach a 4-pin power cable to the power connector on the back of the drive (see Figure 1). The recommended 4-pin power connector is an AMP 1-48024-0 housing with AMP 60617-1 pins or equivalent.
9. Register your drive through our Web site at [www.quantum.com/registration](http://www.quantum.com/registration).