

Quick Start Guide

This Quick Start Guide explains how to unpack, install, and operate your ValueLoader DLT VS80, ValueLoader DLT VS160, ValueLoader LTO-1, ValueLoader LTO-2, or ValueLoader SDLT 320 including how to correctly handle magazines and tape cartridges.

For additional information, visit www.Quantum.com, refer to the Quantum ValueLoader User's Guide installed as a PDF (portable document format) file on the enclosed CD, or contact Quantum Technical Support and Customer Service by dialing (800) 284-5101.

Note: Adobe Acrobat Reader 5.0 or later is required to view and print PDF documents. To download a free copy of Adobe Acrobat Reader, go to www.adobe.com.

Step 1: Unpack the ValueLoader

- a. Look for markings on the shipping carton that indicate the top. If necessary, position the carton so that it is top-side up.
- b. Using scissors, a utility knife, or other appropriate tool, carefully cut the packing tape along the length and ends of the carton.
- c. Remove the accessories from the shipping carton and check the contents. The accessories include the following items:
 - SCSI cable and terminator
 - Regulatory insert and documentation
 - Power cord

If this is a rackmount installation, check the rack kit contents. The rack kit contains the following items:

- Hardware kit with clip nuts and bolts
 - Mounting rails
 - Fixing flanges
- d. Lift the ValueLoader and padding out of the box and place it on a work surface, top facing up.
 - e. Carefully remove the foam packaging from the ValueLoader and then remove the bag.

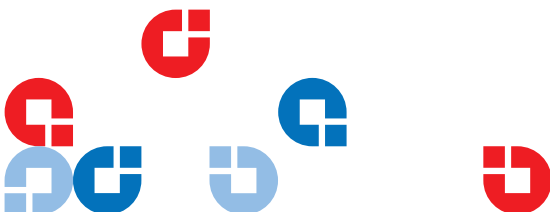
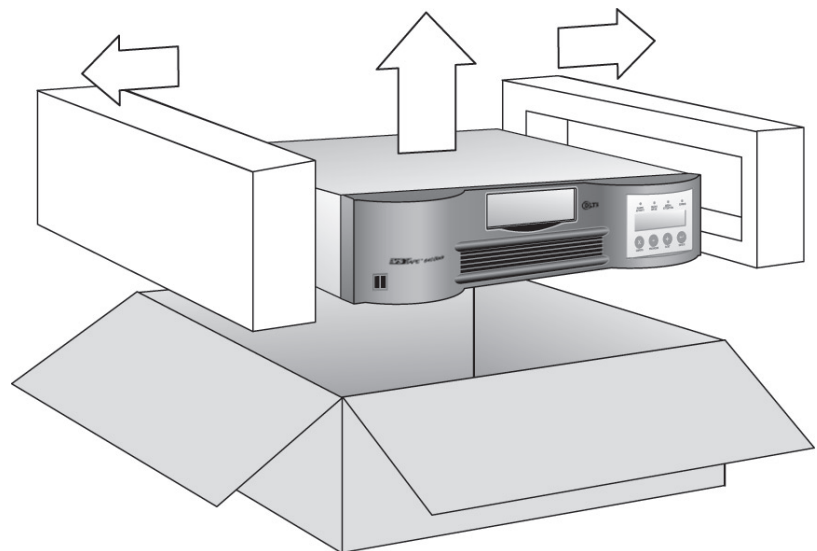

Step 2: Choose a Location

Select a location for the ValueLoader that has adequate clearance for ventilation, minimal dust and debris, and an appropriate power source nearby.

If this is a standalone installation, select a location that is flat, sturdy, and level. Do not place the ValueLoader on its side or stack items on top of the ValueLoader.

Step 3: Install the ValueLoader into a Rack

If this is a rackmount installation, install the ValueLoader into a rack by doing the following:

- Securing the fixing flanges on the sides of the ValueLoader
- Installing the mounting rails into the rack
- Securing the flanges to the mounting rails

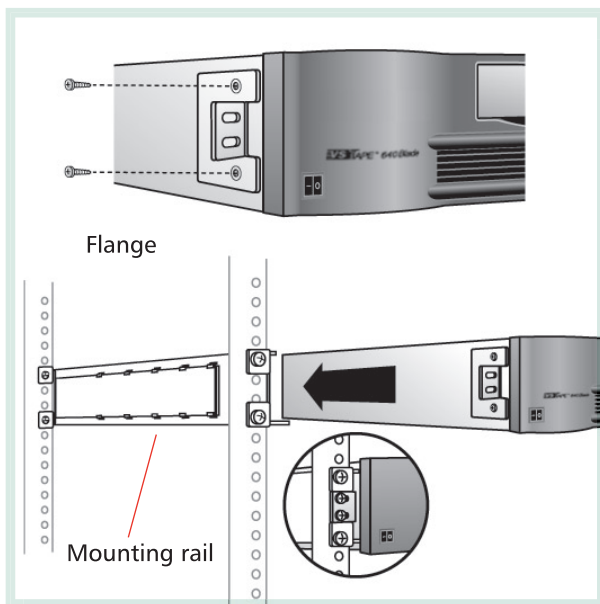

Step 4: Cabling the ValueLoader

- a. Ensure that all devices on the SCSI bus are powered off.
- b. Attach a SCSI cable from the SCSI bus to one of the SCSI connectors on the back panel of the ValueLoader.

- c. If the ValueLoader is the last device on the SCSI bus (or the only device), attach a SCSI terminator to the other SCSI connector on the back panel of the ValueLoader.

If the ValueLoader is not the last device of the SCSI bus, attach a SCSI cable from the open connector on the back panel of the ValueLoader to the next device on the bus.

- d. Connect a power cord from the back panel of the ValueLoader to a grounded power source.

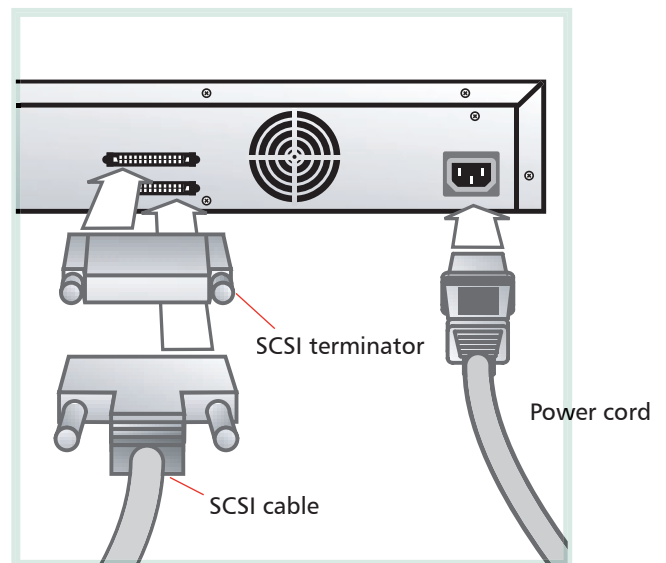

Step 5: Prepare the Host

If necessary, install a SCSI host bus adapter, software, and a compatible driver on the host computer. Connect the SCSI bus to the host computer.

Step 6: Turn on the ValueLoader

Turn on the ValueLoader by pressing the power button on the front panel. Power on the host and all attached SCSI devices.

Operating the ValueLoader

The following sections provide an overview of ValueLoader operations.

Importing Cartridges. Load tapes into the ValueLoader by using the **Import** command from the front panel and then inserting the data cartridge into the mailslot.



Exporting Cartridges. Unload tape cartridges from the ValueLoader by using the **Export** command from the front panel. The selected cartridge automatically ejects.

Loading Cartridges. Load tape cartridges from the ValueLoader slots into the tape drive by using the **Load Cartridge** command from the front panel.

Unloading Cartridges. Unload tape cartridges from the tape drive to the ValueLoader slots by using the **Unload Cartridge** command from the front panel.

Cleaning the Tape Drive. Clean the tape drive when the Clean Drive LED is illuminated. Use the **Clean Drive** command from the front panel to import a cleaning cartridge into the ValueLoader and begin the cleaning operation.

Ordering Media. To prolong the life of the ValueLoader tape drive, use ValueLoader storage media. ValueLoader tape cartridges and cleaning cartridges have been designed in conjunction with the ValueLoader tape drive. For purchase information, go to www.Quantum.com.

Menu: ValueLoader DLT VS80/VS160

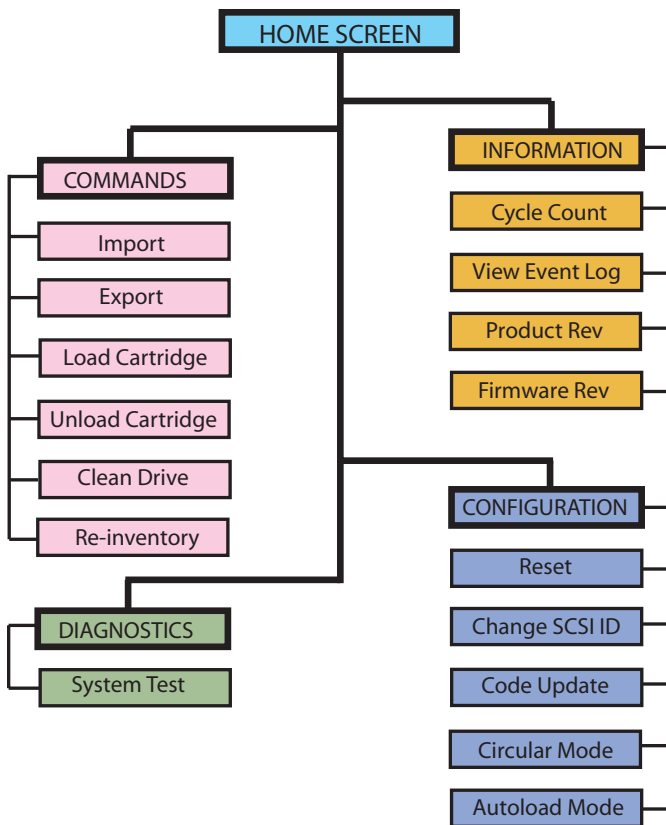

Menu: ValueLoader LTO-1/LTO-2/SDLT 320

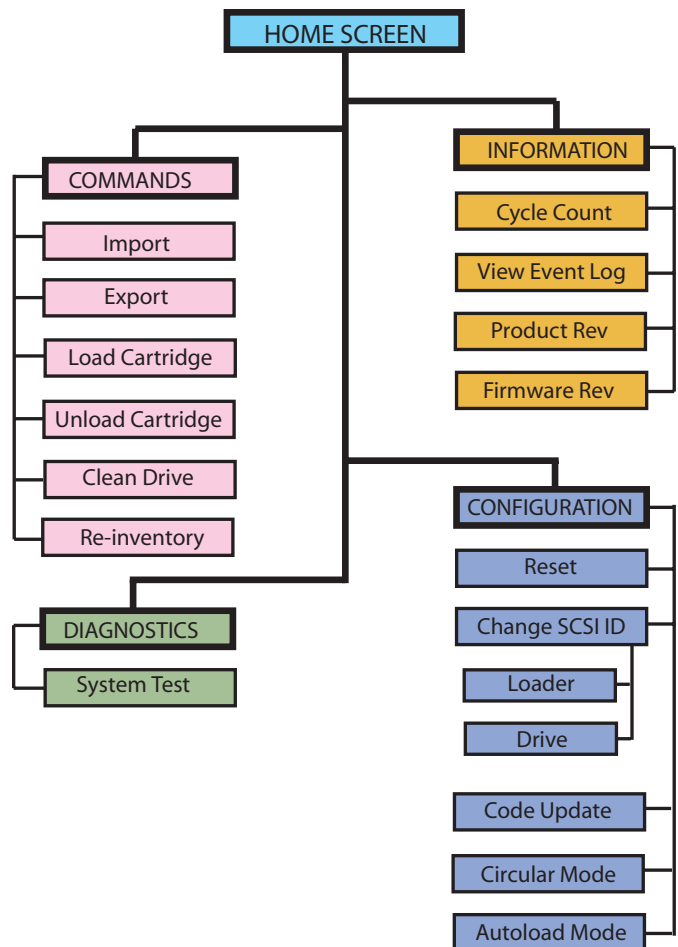

For more information,
visit our Web site at
www.Quantum.com

United States of America
Quantum Corporation
Storage Systems
141 Innovation Drive
Irvine, CA 92612
U.S.A.
phone 949.856.7800
fax 949.856.7799

Europe
7 Lindenwood
Chineham Business Park
Basingstoke, RG24 8QY
United Kingdom
phone +44 1256 818300
fax +44 1256 848700

Asia Pacific
Level 3
200 Creek Street
Brisbane, Qld 4000
Australia
phone +61 7 3839 0950
fax +61 7 3839 0955