

SuperLoader™ Slide Rail Kit Installation Quick Start Guide

This Quick Start Guide contains a sequence of steps recommended for unpacking and installing a slide rail kit for the SuperLoader.

For additional information, visit www.quantum.com, refer to the *Quantum Superloader Automated Tape Library User Manual* installed as a PDF (portable document format) file on the enclosed CD, or contact Quantum Technical Support and Customer Service by calling 1-800-284-5101.

Note: Adobe® Acrobat® Reader is required to view and print PDF documents. To download a free copy of Adobe Acrobat Reader, go to www.adobe.com.

Step 1: Unpack the Slide Rail Kit

- a. Look for markings on the shipping carton that indicate the top. If necessary, position the carton so that it is top-side up.
- b. Using scissors, a utility knife, or other appropriate tool, carefully cut the packing tape along the length and ends of the carton. Fold open the carton flaps.
- c. Remove the following from the carton:
 - Plastic bag containing instructions and warranty information
 - Slide rail shelf (#70-60583-00)
 - Slide rail hardware kit

Step 2: Prepare Parts and Tools

- a. Make sure you have the following parts:
 - One shelf assembly with slides attached (#70-60583-00)
 - Two rack-mounting brackets (#74-60674-00)
 - Four rear-mounting slide brackets (two short, two long)
 - 12 pan-head PHILLIPS® screws (10-32 x .38)
 - Four pan-head PHILLIPS screws (10-32 x .25)
 - Four locking nuts (10-32)
 - Six threaded flat plates (10-32)

Note: Clips, nuts, and attachment screws are not provided. Due to possible differences in cabinet design, you must use cabinet-specific hardware components.

- b. Make sure you have the following tools:
 - #2 PHILLIPS screwdriver

Step 3: Install the Slide Rail

Caution: If the SuperLoader shelf assembly is extended, make sure that you always use a cabinet anti-tip device if one is provided with the cabinet.

- a. Identify the correct mounting holes on the vertical rail, making sure that the holes are all on the same level.



b. Separate the outer pieces of the slides from the shelf assembly. The slides are made up of three telescoping pieces. If you pull on the outer slide, the pieces extend, making the slide longer.

c. From the front, mount the outer pieces of the slides into the cabinet (per previously located holes) using the screws and threaded plates. To do this:

- (1)** Select the long or short rear-mounting slide brackets, depending on the rail-to-rail spacing in the side of the cabinet.
- (2)** Secure the rear-mounting brackets to the slide using the screws and nuts or the treaded flat plate.

Note: Do not fully tighten the mounting screws. This allows for adjustment while inserting the shelf assembly into the mounted slides.

d. Attach the shelf assembly to the slide rails. To do this, extend the slide rails on both sides and then attach the shelf to the rails.

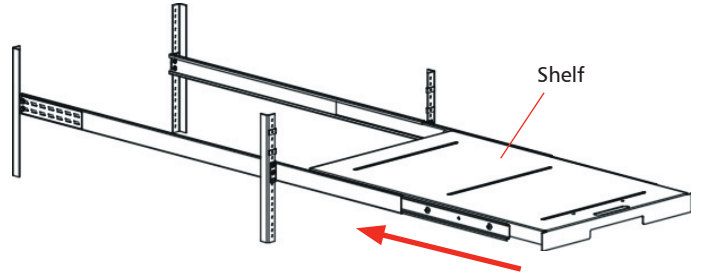

e. After inserting the shelf onto the rails, slide the shelf slowly in and out of the cabinet a few times (to make sure it moves freely) and then tighten all slide screws.

f. Push the shelf all the way into the cabinet in preparation for the next step.

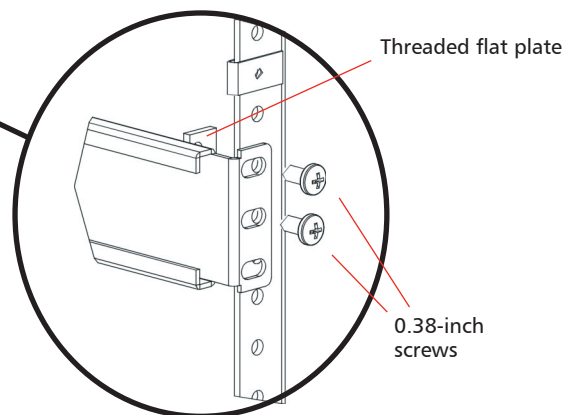
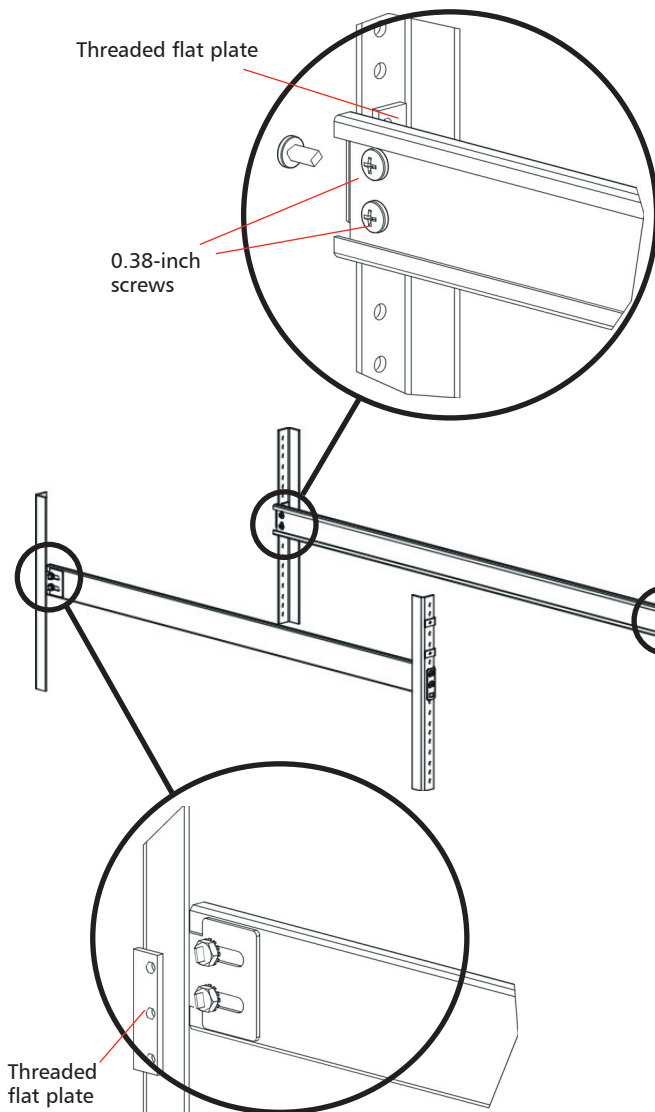
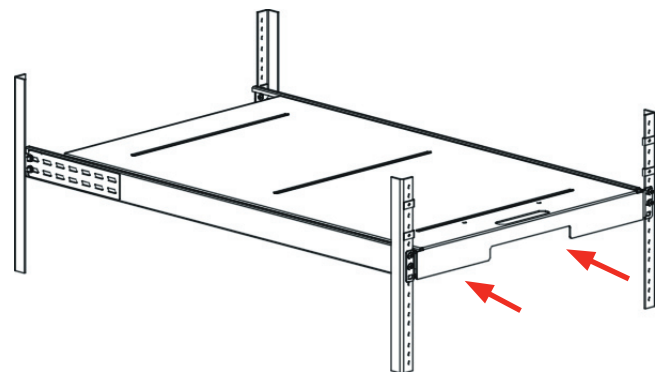

Warning: To avoid injury or equipment damage, it is recommended that two persons lift the SuperLoader and place it on the slide rail shelf.

- g. With the help of a second person, place the SuperLoader on the shelf. Push the SuperLoader to the back of the shelf.
- h. At the back of the cabinet, attach the SuperLoader to the shelf using the two brackets (#74-60674-00), four short pan head screws (#10-32 x 0.25), and four long pan head screws (#10-32 x 0.38) as follows:

Note: Make sure that you use the 0.25-inch screws in the vertical holes, not the 0.38-inch screws. Use the 0.38-inch screws in the horizontal holes.

- (1) Line up the vertical screw holes on a bracket with the vertical screw holes on one of the rear corners of the SuperLoader. Using two short pan head screws, secure the bracket to the SuperLoader.
- (2) Repeat the previous step to attach a bracket to the other side of the SuperLoader.
- (3) Using the long pan head screws, attach both brackets to the shelf using the horizontal screw holes.

- i. At the front of the cabinet, install 4 clip nuts (provided with the cabinet) so that they are level with the screw holes (two per side) in the SuperLoader mounting flanges.
- j. Use four cabinet attachment screws (provided with the cabinet) to lock the SuperLoader in place in the cabinet.

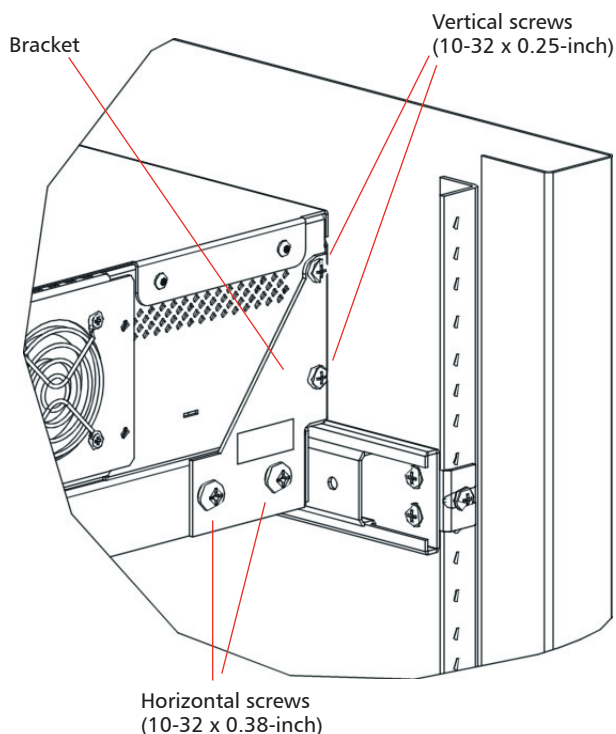
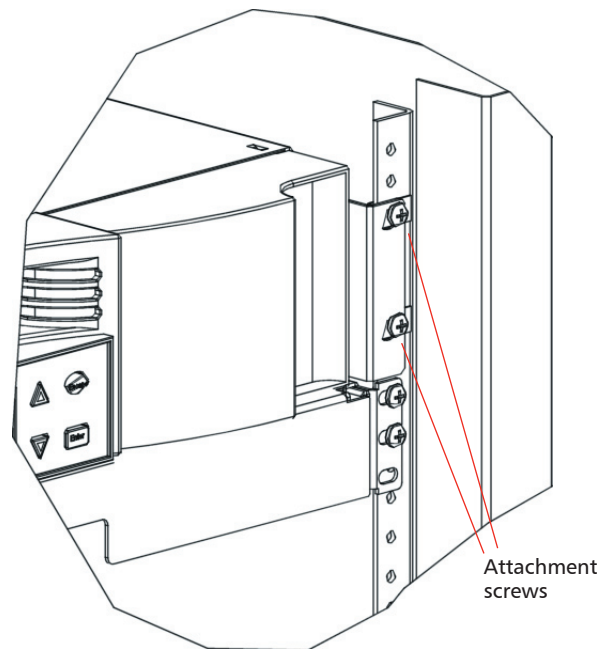

For more information,
visit our Web site at
www.quantum.com

United States of America
Quantum Corporation
Storage Solutions Group
141 Innovation Drive
Irvine, CA 92612
U.S.A.
phone 949.856.7800
fax 949.856.7799

Europe
7 Lindenwood
Chineham Business Park
Basingstoke, RG24 8QY
United Kingdom
phone +44 1256 818300
fax +44 1256 848700

Asia Pacific
Level 3
200 Creek Street
Brisbane, Qld 4000
Australia
phone +61 7 3839 0950
fax +61 7 3839 0955

© 2004 Quantum Corporation. All rights reserved. DLTape, the DLTape logo, Quantum, the Quantum logo, SuperDLTape, the Super DLTape logo, and SuperLoader are trademarks of Quantum Corporation registered in the U.S.A. and other countries. Products mentioned herein are for identification purposes only and may be registered trademarks or trademarks of their respective companies. All other brand names or trademarks are the property of their respective owners.