



# A-Series Tape Drives Quick Start Guide

This document provides basic installation and configuration instructions for the Quantum A-Series Tape Drives.

- SDLT 600A
- LTO-3A

For more information, see the *A-Series Tape Drives User's Guide* (81-81487) and the *A-Series FTP File Server User's Guide* (81-81800) on the documentation CD provided with your tape drive.

- 1 Inspect the shipping box and contents of the box for damage. If you find any damage, report it to the shipping company or contact Quantum immediately.
- 2 Verify that the Ethernet cables are compatible with the connectors on the host computer.

This guide uses the following conventions:

**Note:** Notes emphasize important information related to the main topic.

**Caution:** Cautions indicate potential hazards to equipment and are included to prevent damage to equipment.

The A-Series tape drives are available in two configurations, tabletop and rackmount. Follow the installation procedures appropriate to your tape drive (see [Installing the Tabletop Tape Drive](#) or [Installing the Rackmount Tape Drive](#)). Refer to [figure 1](#) for an example of an A-Series tabletop drive.

**Note:** It is recommended that you review this entire document prior to beginning the installation.

## Contents

Taking ESD Precautions.....	2
Installing the Tabletop Tape Drive....	3
Connecting the Tape Drive.....	4
Installing the Rackmount Tape Drive	5
Connecting the Tape Drive.....	5
Configuring the A-Series Tape Drive	7
The Java Plug-in .....	7
Certificate of Security .....	8
Using the FTP Client .....	8
FTP Client Tab .....	8
File Panes .....	10
File Transfers.....	10
Formatting Media Cartridges .....	11

Figure 1 SDLT 600A Tabletop Drive.



## Taking ESD Precautions

Some components within the tape drive contain static-sensitive parts. To avoid damaging these parts while performing installation procedures, always observe the following precautions:

- Ensure that the work area is free from conditions that could cause electrostatic discharge (ESD).
- Discharge static electricity from your body by touching a known grounded surface, such as your computer's metal chassis.
- Use an antistatic wrist strap.
- Keep static-sensitive parts in their original shipping containers until ready for installation. Look for the ESD sticker to identify static sensitive parts.



- Avoid touching connectors and other components.

**Note:** Dry climates and cold-weather heating environments have lower relative humidity and are more likely to produce static electricity.

## Installing the Tabletop Tape Drive

To check that the tabletop tape drive works and is not damaged:

- 1 Connect one end of the power cord to the tape drive power cord connector on the rear of the tape drive; connect the other end of the cord to an AC outlet.
- 2 Power on the tape drive using the switch on the rear panel (see [figure 2](#)).

Figure 2 Checking the Tabletop Tape Drive

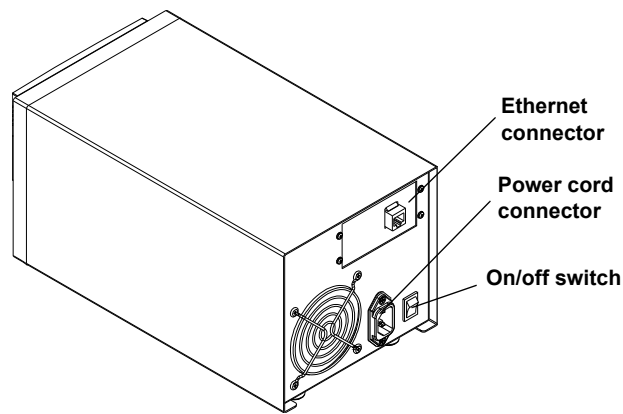

The tape drive performs a self-diagnostic test, called a power on self-test (POST), each time you power it on. The sequence varies depending on the drive type.

Table 1 POST Sequence

A-Series Tape Drive	POST Sequence
SDLT 600A	Each LED lights in sequence. Upon successful completion, the middle LED remains On. All others turn Off.
LTO-3A	The LEDs flash a few times. Upon successful completion, the top LED remains On. All others turn Off.

## Connecting the Tabletop Tape Drive

Connect the tabletop tape drive to the host computer through the network port:

- 1 Connect one end of an Ethernet cable (use either a straight cable or crossover cable) to the network port located on the rear of the tape drive. The system will auto-configure based on the type of cable used.
- 2 Connect the other end to a network switch or router (see [figure 3](#))

The drive may be connected directly to a computer host network port; no external network is necessary.

**Note:** The GigE network port is backward compatible with 100BaseT and 10BaseT networks. To get the full performance of your A-Series tape drive, it is advisable to use a GigE network.

- 3 Proceed to [Configuring the A-Series Tape Drive](#).

Figure 3 Connecting to the Network Port

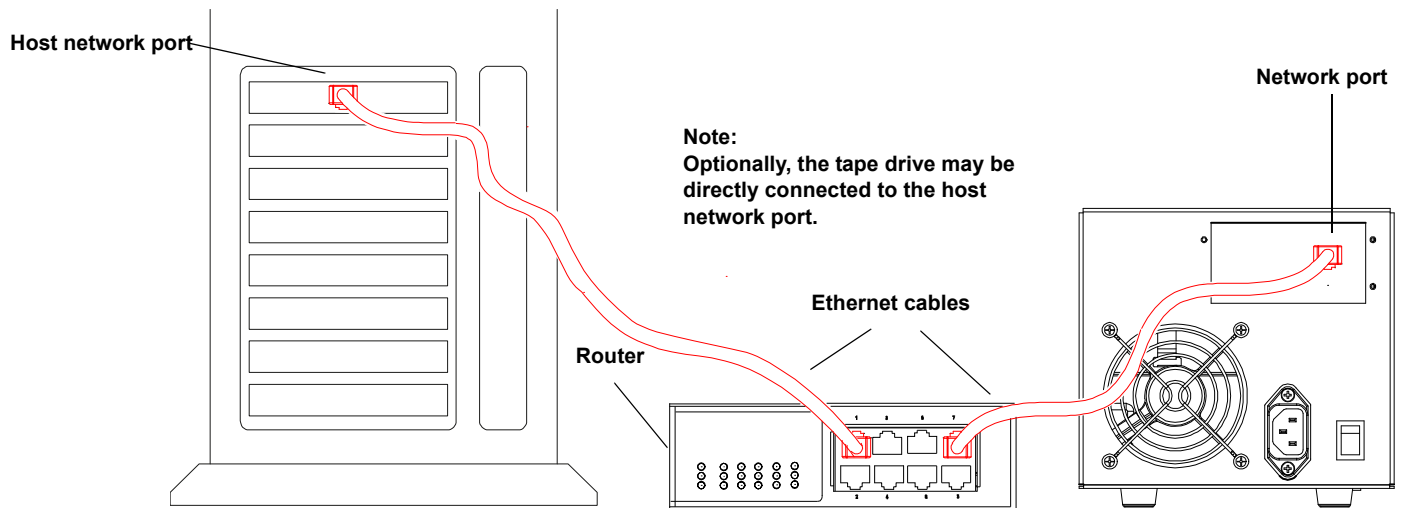

## Installing the Rackmount Tape Drive

To check that the rackmount tape drive works and is not damaged:

- 1 Connect one end of the power cord to the tape drive power cord connector and plug the other end of the power cord into an AC outlet (see [figure 6](#)).
- 2 Power on the tape drive using the switch on the front panel (see [figure 4](#)).

Figure 4 Checking the Rackmount Tape Drive

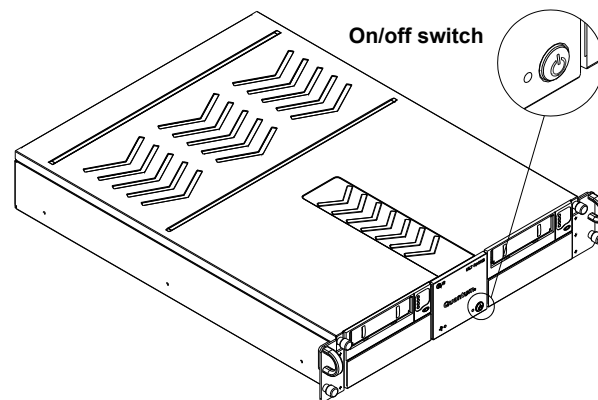

The tape drive performs a self-diagnostic test, called a power on self-test (POST), each time you power it on. The sequence varies depending on the drive type (see [table 1](#)).

### Connecting the Rackmount Tape Drive

Install the rackmount tape drive in a rack and then connect the drive to a network through the network (GigE) port located on the rear of the drive:

- 1 Slide the rackmount tape drive into the equipment rack (see [figure 5](#)).

Figure 5 Installing the Rackmount Tape Drive

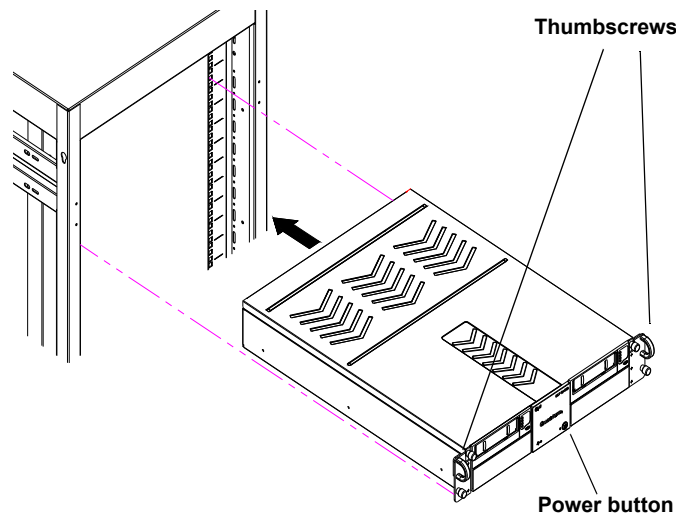

- 2 Secure the unit to the rack with the thumbscrews.
- 3 Connect the power cable to the rear of the rackmount A-Series tape drive (see [figure 6](#)).

Figure 6 Connecting the Power and Network Cables

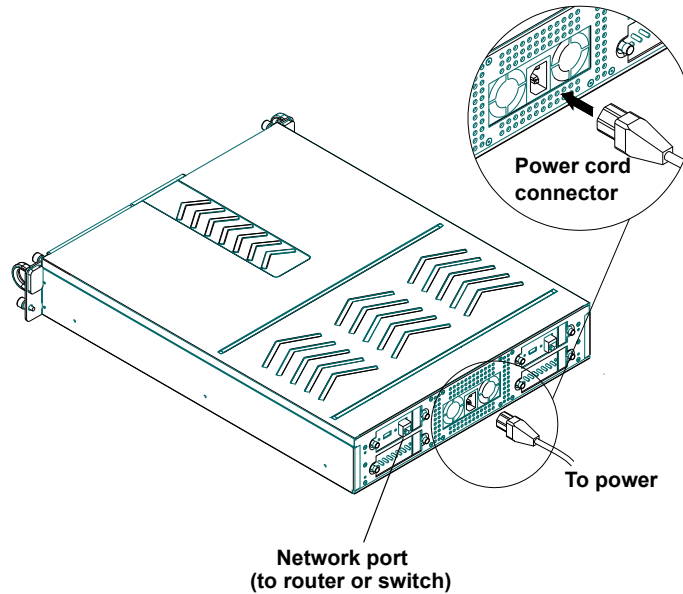

- 4 Connect one end of the Ethernet cable to the network port located on the rear of the A-Series tape drive and connect the other end to a network switch or router.
- 5 Power on the tape drive using the switch on the front panel of the rackmount unit.
- 6 Proceed to [Configuring the A-Series Tape Drive](#).

## Configuring the A-Series Tape Drive

A-Series tape drives have a default IP configured to 10.10.10.10 and can be accessed at that address through any Web browser or FTP client.

Complete instructions for configuring any computer to communicate with A-Series systems and for changing A-Series IP addresses may be found in the *A-Series FTP File Server User's Guide* (81-81800).

To access the drive, type in the IP address of the drive (**http://10.10.10.10**) in the address line of any browser.

**Note:** If you require additional assistance when changing IP settings, you may need to consult either your network administrator or an authority on IP policies and standards.

**Caution:** Any change of the IP address could result in the loss of the device; always double-check that the IP number is entered correctly.

### The Java™ Plug-in

The only software required on your system is a browser and the **Java Plug-in**. The **Java Plug-in** is the virtual machine software that allows the execution of Java applets.

The Java FTP client needs the Java Virtual Machine to run. This **Java Plug-in** is provided by Sun Microsystems.

The Java FTP client will install immediately. When you load the Java FTP client for the first time, a display window may ask you to download and install the Java plug-in. If you need that plug-in you can just follow the instructions on the screen or go to [www.java.com](http://www.java.com) to download it.

If you have **Java Plug-in** version 1.5 or later or the **Java Runtime Environment** version 1.5 or later installed on your computer, you should not need to download new software. The plug-in should activate on your Web browser automatically once installed. For Mac OS® X, the supported JRE version is 1.4.2 and later.

## Certificate of Security

Since the Java FTP client reaches the local directories of your computer, a certificate of security is required. When the Java FTP client is loaded, the **Java Plug-in** displays a window prompting you to accept our certificate of security.

Figure 7 Certificate of Security



## Using the FTP Client

The A-Series Client/FTP client allows you to transfer files to and from the tape drive, partially restore MXF files, and view the MXF metadata.

### FTP Client Tab

In the **Home** page, **FTP Client** is the main tab view with a standard FTP client interface, providing two file panes. The left pane displays your local disk directory and the right pane shows the A-Series directory.

When the FTP client loads, it attempts to open a connection with the A-Series server (see [figure 8](#)).

The default, factory-set login information for the A-Series server is:

- name: **root**
- password: **password**



Figure 8 FTP Client Login Dialog



After successfully entering the login information you will be connected through this FTP Client Java applet to the A-Series drive and be presented with a screen similar to the one shown in [figure 9](#) below.

This screen offers menu selections in the left-most column and shows two panes containing file listings for your local hard drive and for the tape in the A-Series drive on the right side of the page.

Once connected, you can disconnect from the A-Series server by clicking the **Disconnect** button.

Figure 9 A-Series FTP Client

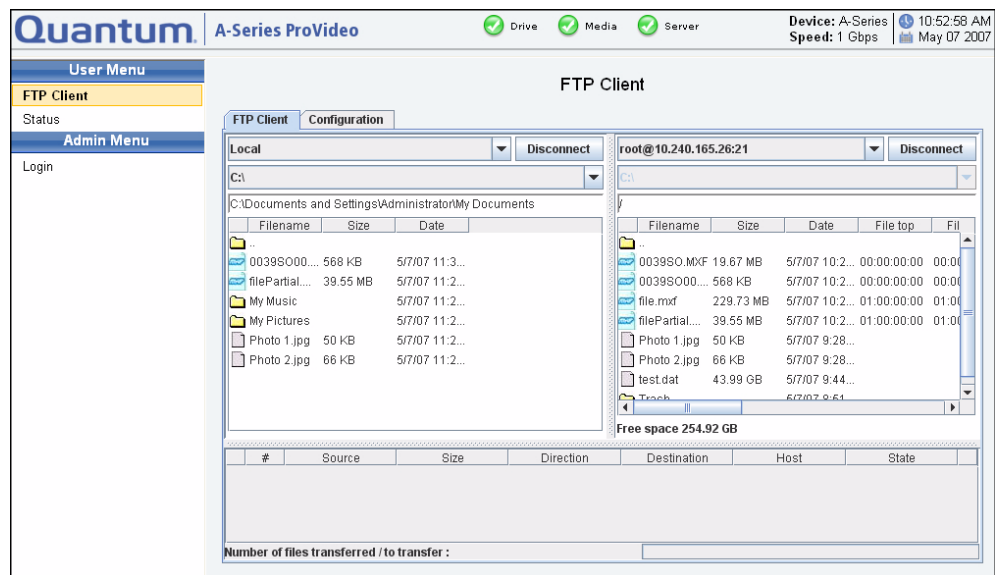

---

## File Panes

---

There are three text zones on the top of each pane:

- The first zone allows you to select the system or server.
- The second zone allows you to select the drive letter (only available on **Local** when connected to Windows systems).
- The third zone displays the currently navigated path and allows you to type the path within the address bar.

The panes can be local or remote views and you can interact with the system as follows:

- Double-click a folder to expand it to view the enclosed folders and files.
- Double-click the up-arrow folder at the top followed by leader dots that lead toward the parent folder.
- Click an item (file or folder) to select it.
- Right-click to see the **Contextual** menu (<Ctrl>+click under Mac OSX).

Consult the *A-Series FTP File Server User's Guide* (81-81800) for more information on selection and display control.

---

## File Transfers

---

The A-Series FTP client allows you to transfer files from a:

- Local PC to/from an A-Series server
- Local PC to/from a non-A-Series server (e.g. Filezilla)
- A-Series server to/from a non-A-Series server
- A-Series server to/from another A-Series server (FXP transfer)

To transfer files, select one or more items in one pane, then drag and drop them to the other pane.

When transferring files of 4 MB and larger, maximum native transfer rates may be achieved. When transferring files of less than 4 MB, you may see degraded drive transfer rates.

Once a transfer is initiated, the Transfer List at the bottom of the page shows all files queued for transfer and progress bars show the transfer progress – when the indicator is moving back and forth or striped, the tape is seeking, and once data copying actually begins the bar shows the progress.

The queue lists the files to transfer as well as the status of the transfer. By selecting a file from the list and then right-clicking it, you can stop file copies, remove files from the list, and see detailed information about any errors which may have occurred.

When the queue is completed, the Transfer File list view automatically switches to Summary View and provides a summary report of the transfer. For more information, consult the *A-Series FTP File Server User's Guide* (81-81800).

---

**Formatting Media Cartridges**

---

To format a media (data) cartridge:

- 1 Insert the appropriate media cartridge into the A-Series tape drive.

**Note:** When the cartridge is new or unformatted, formatting begins automatically with no prompt.

If the tape drive does not recognize a compatible media cartridge (e.g. SDLTtape I or VS160), an error message displays and the cartridge is ejected.

If the tape drive recognizes a valid media cartridge containing data that is not A-Series compatible, a warning message displays.

**Caution:** When formatting with the A-Series tape drive, all existing data on the media cartridge will be overwritten.

- 2 Click **Yes** to start formatting.

**Note:** The initial formatting of a media cartridge takes approximately 30 – 40 seconds.



81-81488-04 A01



For assistance contact Quantum Technical Assistance center:  
North America **+1-800-284-5101**  
UK, France, and Germany **00800 4 QUANTUM**  
EMEA **+44 1256 848 766**

For worldwide support: [www.quantum.com/contactsupport](http://www.quantum.com/contactsupport)

**Quantum**<sup>®</sup>  
**Backup. Recovery. Archive. It's What We Do.**

©2008 Quantum Corporation. All rights reserved. Quantum, the Quantum logo, and all other logos are registered trademarks of Quantum Corporation or their respective owners.

Quantum Corp. (NYSE: QTM) is the leading global storage company specializing in backup, recovery and archive. Combining focused expertise, customer-driven innovation, and platform independence, Quantum provides a comprehensive range of disk, tape, media, and software solutions supported by a world-class sales and service organization. As a long-standing and trusted partner, the company works closely with a broad network of resellers, OEMs, and other suppliers to meet customer's evolving data protection needs.