

# A-Series Tape Drives

## A-Series Tape Drives

Quantum A-Series Tape Drives User's Guide, 81-81487-04 A01, July 2008.

Quantum Corporation provides this publication "as is" without warranty of any kind, either express or implied, including but not limited to the implied warranties of merchantability or fitness for a particular purpose. Quantum Corporation may revise this publication from time to time without notice.

### **COPYRIGHT STATEMENT**

Copyright 2008 by Quantum Corporation. All rights reserved.

Your right to copy this manual is limited by copyright law. Making copies or adaptations without prior written authorization of Quantum Corporation is prohibited by law and constitutes a punishable violation of the law.

### **TRADEMARK STATEMENT**

Quantum, DLT, DLTtape, The Quantum Logo, and The DLTtape Logo are all registered trademarks of Quantum Corporation. SuperLoader, SDLT, and Super DLTtape are trademarks of Quantum Corporation.

Mac and Mac OS are trademarks of Apple Inc., registered in the U.S. and other countries.

Other trademarks may be mentioned herein which belong to other companies.

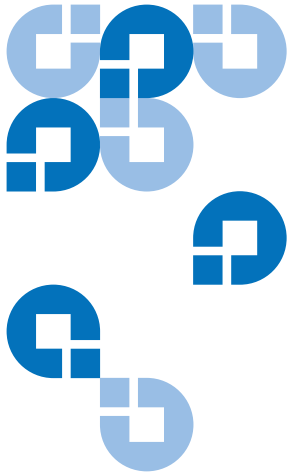

# Contents

---

---

|                |           |
|----------------|-----------|
| <b>Preface</b> | <b>xi</b> |
|----------------|-----------|

---

|                  |                        |          |
|------------------|------------------------|----------|
| <b>Chapter 1</b> | <b>Introduction</b>    | <b>1</b> |
|                  | Overview .....         | 1        |
|                  | Product Features ..... | 3        |

---

|                  |   |          |
|------------------|---|----------|
| <b>Chapter 2</b> | <b>Getting Started</b>                    | <b>5</b> |
|                  | Java™ Plug-in.....                        | 6        |
|                  | The Java Plug-in.....                     | 6        |
|                  | Certificate of Security.....              | 6        |
|                  | Resetting System Defaults .....           | 7        |
|                  | SDLT 600A Drive Reset .....               | 8        |
|                  | LTO-3A Drive Reset .....                  | 8        |
|                  | Warranty Note.....                        | 9        |
|                  | Safety, Handling, and ESD Protection..... | 9        |
|                  | Safety Precautions .....                  | 9        |
|                  | Handling .....                            | 10       |
|                  | Electrostatic Discharge Protection.....   | 11       |

---

**Chapter 3****Using Your Tape Drive****12**

|   |    |
|---|----|
| Front Panel LEDs and Tape Eject .....             | 13 |
| SDLT 600A .....                                   | 13 |
| LTO-3A.....                                       | 16 |
| A-Series Data Cartridges.....                     | 18 |
| Write-Protect Switch .....                        | 18 |
| Write Protecting a SDLT 600A Data Cartridge ..... | 18 |
| Write Protecting an Ultrium Data Cartridge .....  | 20 |
| Loading a Data Cartridge.....                     | 20 |
| Unloading a Data Cartridge.....                   | 21 |
| Data Cartridge Care and Maintenance .....         | 22 |
| Power On Self-Test (POST) Troubleshooting .....   | 23 |
| POST Operation .....                              | 23 |
| POST Troubleshooting Tips .....                   | 25 |
| Over Temperature Condition .....                  | 26 |
| Frequently Asked Questions.....                   | 26 |

---

**Appendix A****Specifications****27**

|   |    |
|---|----|
| A-Series SDLT 600A Tape Drive.....                      | 28 |
| Laser Guided Magnetic Recording .....                   | 28 |
| Pivoting Optical Servo .....                            | 28 |
| Magneto Resistive Cluster Heads .....                   | 28 |
| Advanced Partial Response Maximum Likelihood .....      | 29 |
| Advanced Metal Powder Media.....                        | 29 |
| Positive Engagement Tape Leader Buckling Mechanism..... | 29 |
| Modular Design .....                                    | 29 |
| Data Control Module .....                               | 31 |
| Tape Control Module .....                               | 31 |
| Front Panel Module.....                                 | 32 |
| Electronic Interface Module .....                       | 33 |
| Super DLTtape II Data Cartridge .....                   | 33 |
| Product Specifications .....                            | 34 |
| Positive Engagement Tape Leader Buckling Mechanism..... | 34 |
| Functional Specifications .....                         | 34 |
| Performance Data .....                                  | 34 |
| Shock and Vibration Specifications.....                 | 35 |
| Current and Power Requirements .....                    | 38 |
| SDLT 600A Tape Drive Recording Method .....             | 41 |
| Environmental Specifications.....                       | 41 |

|   |    |
|---|----|
| Air Flow Requirements .....                                 | 41 |
| Temperature and Humidity .....                              | 41 |
| Storage and Shipment .....                                  | 42 |
| Altitude .....  | 43 |
| Recording Media Specifications.....                         | 43 |
| Media Structure.....  | 43 |
| Physical Data Cartridge .....                               | 44 |
| Media Shipping, Operating, and Storage Specifications ..... | 45 |
| A-Series LTO-3A Tape Drive .....                            | 46 |
| Power Specifications.....                                   | 46 |
| Drive Performance Specifications.....                       | 47 |
| Environmental Requirements .....                            | 49 |
| Reliability Specifications .....                            | 50 |
| Mean Time Between Failures.....                             | 50 |
| Mean Time to Replace.....                                   | 51 |
| LTO Cartridge Specifications .....                          | 51 |
| Environmental Considerations .....                          | 51 |
| Cartridge Memory .....                                      | 52 |
| Cartridge Reliability .....                                 | 52 |

---

## Appendix B

|   |           |
|---|-----------|
| <b>Data Cartridges</b>                                    | <b>53</b> |
| Using Data Cartridges for the SDLT 600A .....             | 53        |
| Data Cartridge Handling Guidelines.....                   | 54        |
| Data Cartridge Inspection Procedure .....                 | 56        |
| Data Cartridge Write-Protect Switch .....                 | 60        |
| Using Data Cartridges for the LTO-3A.....                 | 62        |
| Loading a Tape Cartridge.....                             | 62        |
| Unloading a Tape Cartridge .....                          | 62        |
| Write Protecting a Tape Cartridge .....                   | 63        |
| Tape Cartridge Care and Maintenance .....                 | 64        |
| Cleaning the Tape Mechanism.....                          | 65        |
| Occasional Cleaning of Tape Head .....                    | 65        |
| SDLT 600A .....   | 65        |
| Life Expectancy of the Cleaning Tape .....                | 65        |
| Compatibility of the Cleaning Tape.....                   | 66        |
| Loading the Cleaning Tape Into a Tabletop Tape Drive..... | 66        |
| LTO-3A .....  | 66        |
| Performing an Emergency Reset and Cartridge Eject .....   | 68        |
| Loading a Data Cartridge .....                            | 69        |
| Unloading a Data Cartridge .....                          | 70        |

---

**Appendix C****Regulatory Compliance****71**

|   |    |
|---|----|
| SDLT 600A .....                                       | 72 |
| Safety Certifications.....                            | 72 |
| Electromagnetic Field Specifications .....            | 72 |
| Electromagnetic Emissions.....                        | 72 |
| Electromagnetic Interference Susceptibility .....     | 73 |
| Immunity and ESD Limits.....                          | 73 |
| Acoustic Noise Emissions.....                         | 74 |
| LTO-3A .....  | 75 |
| Environmental Compliance.....                         | 77 |
| Perchlorate Material .....                            | 77 |
| Disposal of Electrical and Electronic Equipment ..... | 78 |

---

**Glossary****79**

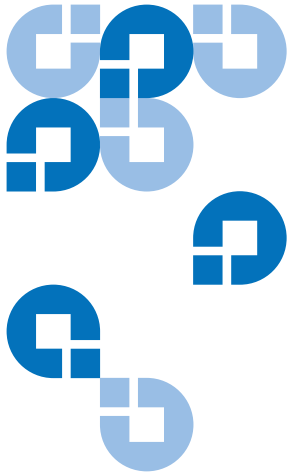

# Figures

---

|           |   |    |
|-----------|---|----|
| Figure 1  | SDLT 600A Tabletop Drive.....                             | 2  |
| Figure 2  | Certificate of Security .....                             | 7  |
| Figure 3  | SDLT 600A Front Panel Display .....                       | 13 |
| Figure 4  | LTO-3A Front Panel Display .....                          | 16 |
| Figure 5  | Super DLTtape II Data Cartridge .....                     | 18 |
| Figure 6  | Write-protect Switch on Super DLTtape II Data Cartridge . | 19 |
| Figure 7  | Write-protect Switch on Ultrium Data Cartridge.....       | 20 |
| Figure 8  | Loading a Super DLTtape II Data Cartridge.....            | 21 |
| Figure 9  | SDLT 600A Tape Drive Front Panel LEDs.....                | 24 |
| Figure 10 | SDLT 600A Tape Drive Modular Design.....                  | 30 |
| Figure 11 | Multiple Layers Comprise Super DLTtape II Media .....     | 44 |
| Figure 12 | Super DLTtape II Data Cartridge .....                     | 44 |
| Figure 13 | Super DLTtape II Media Shipping Limits .....              | 45 |
| Figure 14 | Super DLTtape II Data Cartridge .....                     | 54 |
| Figure 15 | Bottom View of Super DLTtape II Data Cartridge.....       | 57 |
| Figure 16 | Super DLTtape II Data Cartridge Reel Locks .....          | 58 |
| Figure 17 | Opening the Super DLTtape II Data Cartridge Door .....    | 58 |

|           |   |    |
|-----------|---|----|
| Figure 18 | Problems to Look for Inside the Data Cartridge Door.....  | 59 |
| Figure 19 | Write-Protect Switch on Super DLTtape II Data Cartridge . | 60 |
| Figure 20 | Ultrium Tape Cartridge Write-Protect Switch.....          | 63 |
| Figure 21 | Loading a Super DLTtape II Data Cartridge.....            | 69 |



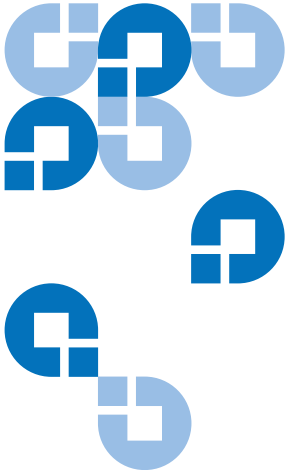

# Tables

---

|          |   |    |
|----------|---|----|
| Table 1  | Storage Capacity and Transfer Rates .....                 | 3  |
| Table 2  | SDLT 600A LED Codes .....                                 | 14 |
| Table 3  | LTO-3A LED Codes .....                                    | 17 |
| Table 4  | LED Lighting Pattern During Power-On Self-Test (POST)..   | 23 |
| Table 5  | Troubleshooting Chart .....                               | 25 |
| Table 6  | SDLT 600A Tape Drive Performance Data.....                | 34 |
| Table 7  | Non-operating Shock Specifications (Unpackaged) .....     | 35 |
| Table 8  | Non-Operating Shock Specifications (Packaged, Drop).....  | 36 |
| Table 9  | Non-Operating Vibration Specifications (Unpackaged) ..... | 36 |
| Table 10 | Non-Operating Vibration Specifications (Packaged).....    | 37 |
| Table 11 | Operating Shock and Vibration Specifications .....        | 37 |
| Table 12 | Current Requirements – SCSI Interface .....               | 38 |
| Table 13 | Power Requirements – SCSI Interface.....                  | 40 |
| Table 14 | Temperature and Humidity Specification.....               | 42 |
| Table 15 | Tape Drive Storage and Shipment Specifications .....      | 42 |
| Table 16 | Super DLTtape II Media Specifications .....               | 43 |
| Table 17 | Super DLTtape II Media Operating Limits .....             | 45 |

|          |   |    |
|----------|---|----|
| Table 18 | Super DLTtape II Media Storage Limits .....         | 45 |
| Table 19 | LTO-3A Physical Specifications .....                | 46 |
| Table 20 | Drive Performance Specifications .....              | 47 |
| Table 21 | Environmental Requirements.....                     | 49 |
| Table 22 | Reliability Specifications .....                    | 50 |
| Table 23 | Environmental Tolerances .....                      | 51 |
| Table 25 | Write-Protect Switch Positions.....                 | 61 |
| Table 26 | EMI Regulations and Certifications.....             | 73 |
| Table 27 | Immunity and ESD Failure Level Limits .....         | 73 |
| Table 28 | Acoustic Noise Emissions, Nominal.....              | 74 |
| Table 29 | Safety Compliance.....                              | 75 |
| Table 30 | Electromagnetic Compatibility (EMC) Compliance..... | 76 |

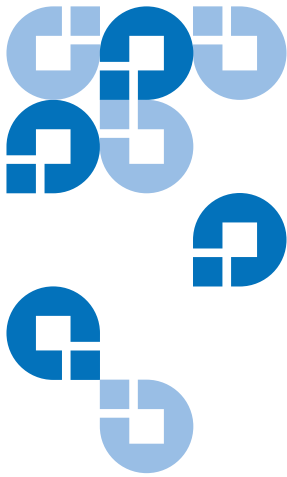

# Preface

---

This document serves as an easy-to-use information source to familiarize Quantum customers and systems professionals with the A-Series tape drives.

---

## **Audience**

---

The primary audience for this document consists of end users installing and using the tape drive.

---

## **Purpose**

---

This document provides information on the A-Series tape drives including:

- Product features
- Safety, handling, and ESD protection
- Resetting system defaults
- The Java Plug-in
- Front panel LEDs
- Regulatory compliance and statements

---

## Document Organization

---

This document is organized as follows:

- [Chapter 1, Introduction](#), provides an overview of the tape drive and product features.
- [Chapter 2, Getting Started](#), includes information on the Java Plug-in, resetting system defaults, and warranty, safety, handling, and ESD precautions.
- [Chapter 3, Using Your Tape Drive](#), provides information on the front panel controls and LEDs, data cartridges, and POST.
- [Appendix A, Specifications](#), provides product, functional, environmental, and recording media specifications.
- [Appendix B, Data Cartridges](#), provides information on recognizing, handling, inspecting, write-protecting, loading, and unloading cartridges.
- [Appendix C, Regulatory Compliance](#), provides electromagnetic field specifications, acoustic noise emissions, and environmental compliance.

This document concludes with a glossary.

---

## Notational Conventions

---

This document uses the following conventions:

**Note:** Notes emphasize important information related to the main topic.

**Caution:** Cautions indicate potential hazards to equipment and are included to prevent damage to equipment.

**Warning:** Warnings indicate potential hazards to personal safety and are included to prevent injury.

This document uses the following:

- Right side of the tape drive – Refers to the right side as you face the component being described.
- Left side of the tape drive – Refers to the left side as you face the component being described.
- Power cycle – Means to turn the tape drive or system on, then turn them off (or off, then on).
- Dimensions in figures – All dimensions are shown with no units specified (Inches understood unless otherwise specified).

---

## Related Documents

---

Documents related to the Quantum A-Series Tape Drives User's Guide are shown below:

| Document No. | Document Title                         | Document Description  |
|--------------|--|---|
| 81-81488     | A-Series Tape Drives Quick Start Guide | Provides "quick" instructions on how to install and run the tape drive. |
| 81-81800     | A-Series FTP File Server User's Guide  | Provides information on how to use the FTP file server.                 |

---

## Contacts

---

Quantum company contacts are listed below.

### Quantum Corporate Headquarters

To order documentation on this or other Quantum products, contact:

Quantum Corporation (*Corporate Headquarters*)  
1650 Technology Drive, Suite 700  
San Jose, CA 95110-1382

### Technical Publications

To comment on existing documentation send e-mail to:

[doc-comments@quantum.com](mailto:doc-comments@quantum.com)

## Quantum Home Page

Visit the Quantum home page at:

[www.quantum.com](http://www.quantum.com)

---

### Getting More Information or Help

---

StorageCare™, Quantum's comprehensive service approach, leverages advanced data access and diagnostics technologies with cross-environment, multi-vendor expertise to resolve backup issues faster and at lower cost.

Accelerate service issue resolution with these exclusive Quantum StorageCare services:

- **Service and Support Website** - Register products, license software, browse Quantum Learning courses, check backup software and operating system support, and locate manuals, FAQs, firmware downloads, product updates and more in one convenient location. Benefit today at: [www.quantum.com/support](http://www.quantum.com/support).
- **eSupport** - Submit online service requests, update contact information, add attachments, and receive status updates via email. Online Service accounts are free from Quantum. That account can also be used to access Quantum's Knowledge Base, a comprehensive repository of product support information. Sign up today at: [www.quantum.com/support](http://www.quantum.com/support).

For further assistance, or if training is desired, contact Quantum Technical Assistance Center:

|                        |  |
|------------------------|--|
| North America:         | +1-800-284-5101  |
| UK, France and Germany | 00800 4 QUANTUM  |
| EMEA                   | +44 1256 848 766   |
| For worldwide support: | <a href="http://www.quantum.com/contactsupport">www.quantum.com/contactsupport</a> |

For the most up to date information on Quantum Global Services, please visit [www.quantum.com/support](http://www.quantum.com/support).

---

## Software License

---

The A-Series Tape Drives use *edtFTPj 1.4.5* Java API which is under the GNU Lesser General Public License (LGPL) and hence can be freely used in commercial or non-commercial products.

It should be noted, however, that under the LGPL, *edtFTPj* must be used as a library and not directly incorporated into codebase.

- *edtFTPj* Web site: [www.enterprisedt.com/products/edtftpj/overview.html](http://www.enterprisedt.com/products/edtftpj/overview.html)
- GNU Lesser General Public License: [www.gnu.org/licenses/lgpl.html](http://www.gnu.org/licenses/lgpl.html)





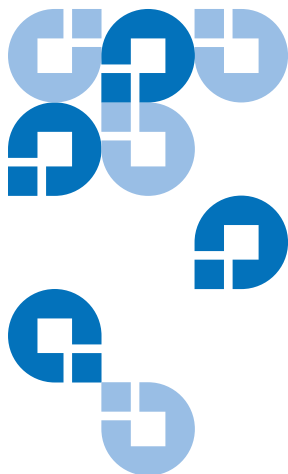

## Chapter 1

# Introduction

---

The Quantum A-Series Tape Drives:

- SDLT 600A
- LTO-3A

This chapter describes the features of the tape drives and covers the following topics:

- [Overview](#) describes a basic overview of the A-Series tape drives.
- [Product Features](#) lists product features of the A-Series tape drives.

---

## Overview

The Quantum A-Series Tape Drives are an extension to the family of products with video professionals in mind. Using the built-in FTP client in conjunction with a standard Web browser, Material Exchange Format (MXF) files can be stored and retrieved. A Gigabit Ethernet (GigE) interface allows these drives to be quickly connected and accessed on your network.

The A-Series tape drives are ideal for serving a full range of video applications; from hand-carrying video content out to a truck for live production to facility-wide, long-term, secure archive.

The A-Series tape drives are available in two configurations, tabletop (as shown in [figure 1](#)) and rackmount.

---

Figure 1 SDLT 600A Tabletop Drive



## Product Features

The A-Series tape drives offer the following product features:

Table 1 Storage Capacity and Transfer Rates

| A-Series Tape Drive | Maximum Storage Capacity | Maximum Native Data Transfer Rate |
|---------------------|--------------------------|-----------------------------------|
| SDLT 600A           | 300 GB                   | 36 MB/sec                         |
| LTO-3A              | 400 GB                   | 68 MB/sec                         |

- The SDLT 600A tape drive allows for over 6 hours of HD (high definition) and over 25 hours of SD (standard definition) storage on a single Super DLTtape II media cartridge.
- The LTO-3A tape drive allows for over 8 hours of HD and over 33 hours of SD storage on a single Ultrium 3 media cartridge.

**Note:** There is a limitation on the number of files that can be stored on a media cartridge based on the size of the files and the size of the filenames stored on the table of contents (TOC) region of the tape. For example, the A-Series SDLT 600A tape drive can hold approximately 8,000 files. This limit can be significantly smaller if the filenames are long and/or there are many MXF files.

- Convergent technology – the benefits of file-based data tape storage and the accessibility of video tape.
- Built-in Gigabit Ethernet (GigE) interface.
- Access to metadata and clip content by timecode-indexed in and out points through a web-based interface.
- A standard 5.25-inch full-height form factor to simplify integration into system and tape library solutions.
- iTalk (and Pocket DLTSage iTalk) – Infrared (wireless) interface on the SDLT 600A that provides a remote testing base allowing customers and integrators to access system diagnostic information from the front of the tape drive.

- For more information on the SDLT tape products and other product information, go to [www.dlftape.com](http://www.dlftape.com).

This Web page provides information that is constantly updated as needed. Refer to this Web site often to obtain the most current information.

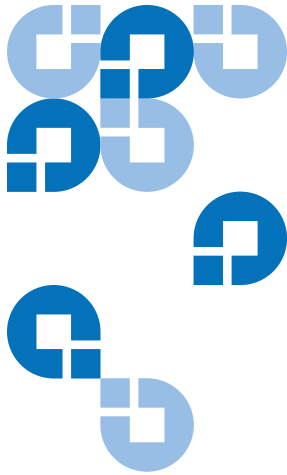

## Chapter 2 Getting Started

---

This chapter provides pointers to information you need to install and configure your A-Series tape drive and also to access and use the A-Series FTP file server.

**Note:** For information on installing and configuring the Quantum A-Series Tape Drive, see the *Quantum A-Series Tape Drives Quick Start Guide* (81-81488).

**Note:** For information on accessing and using the Quantum A-Series FTP File Server, see the *Quantum A-Series FTP File Server User's Guide* (81-81800).

This chapter covers the following topics:

- [Java™ Plug-in](#) provides information about the only software required on your system.
- [Resetting System Defaults](#) provides information on what to do should you lose the IP address of the A-Series tape drive.
- [Warranty Note](#) provides basic warranty information
- [Safety, Handling, and ESD Protection](#) describes appropriate safeguards to use when working with the tape drive.

---

## Java™ Plug-in

The A-Series tape drive utilizes a Web-based interface allowing you to manage the tape drive from a remote workstation on the same network.

The tape drive is configured and managed through Web pages accessible by Internet browser software installed on the host computer.

The only software required on your system is the Java Plug-in. The **Java Plug-in** is the virtual machine software that allows the execution of Java applets.

---

### The Java Plug-in

---

The Java FTP client needs the Java Virtual Machine to run. This **Java Plug-in** is provided by Sun Microsystems.

The Java FTP client will install immediately. When you load the Java FTP client for the first time, a display window may ask you to download and install the Java plug-in. If you need that plug-in you can just follow the instructions on the screen or go to [www.java.com](http://www.java.com) to download it.

If you have **Java Plug-in** version 1.5 or later or the **Java Runtime Environment** version 1.5 or later installed on your computer, you should not need to download new software. The plug-in should activate on your Web browser automatically once installed. For Mac OS® X, the supported JRE version is 1.4.2.

---

### Certificate of Security

---

Since the Java FTP client reaches the local directories of your computer, a certificate of security is required. When the Java FTP client is loaded, the **Java Plug-in** displays a window prompting you to accept our certificate of security (see [figure 2](#)).

Figure 2 Certificate of Security



## Resetting System Defaults

As there is no access to the A-Series tape drive other than the Ethernet port, a mechanism has been implemented to reset the settings to their default values. This is useful if an end user loses the IP address of the A-Series tape drive.

The system defaults are as follows:

| Name              | Password/Setting |
|-------------------|------------------|
| Static IP address | 10.10.10.10      |
| Netmask           | 255.255.255.0    |
| Main login        | admin            |
| Username          | root             |
| Default password  | password         |

---

### SDLT 600A Drive Reset

---

To reset an SDLT 600A tape drive back to default values:

- 1 Disconnect the network cable from the drive.
- 2 Switch off your tape drive.
- 3 Insert a write protected cartridge into the drive.
- 4 Switch on the tape drive (after approximately one minute, the cartridge will be ejected).
- 5 Repeat steps 2 – 4 above two more times.
- 6 After the third cycle, switch off your tape drive.
- 7 Reconnect your network cable and switch on the tape drive.
- 8 Set your cartridge write protection on or off (as you need it) and reinsert the tape (or another tape).
- 9 Access the drive from a browser at the default IP address (10.10.10.10) to reconfigure to your desired settings.

---

### LTO-3A Drive Reset

---

To reset an LTO-3A tape drive back to default values:

- 1 Disconnect the network cable from the drive.
- 2 Insert a write protected cartridge into the drive (wait approximately 30 seconds for tape to load and lights to stop flashing).
- 3 Switch off your tape drive for 10 seconds.
- 4 Switch on the tape drive (after approximately three minutes, the cartridge will be ejected and reloaded; after an additional 30 seconds lights will stop flashing).
- 5 Repeat steps 2 – 4 above two more times.
- 6 After the third cycle, press the eject button on the drive to eject the tape and switch off the drive.
- 7 Reconnect your network cable and switch on the tape drive.
- 8 Set your cartridge write protection on or off (as you need it) and reinsert the tape (or another tape).
- 9 Access the drive from a browser at the default IP address (10.10.10.10) to reconfigure to your desired settings.



---

## Warranty Note

See the warranty before installing your tape drive. Certain actions taken during installation could void the warranty if not properly conducted.

Generally, the Limited Product and Limited Repair Warranties are contingent upon proper use in the application for which the product is intended; and do not cover the product if you perform any of the following actions:

- Modify the product without the manufacturer's written approval.
- Subject the product to unusual physical, environmental, or electrical stress, including damage caused by handling or shipping in unapproved containers or packaging.
- Disturb any warranty labels, or the integrity of the product in any other way.
- Remove or damage the serial number label to the extent that warranty status of the product cannot be determined.

---

## Safety, Handling, and ESD Protection

Inappropriate or careless handling of the A-Series tape drives may result in damage to the product. Follow the precautions and directions to prevent damaging the tape drive.

---

### Safety Precautions

---

For your safety, follow all safety procedures described here and in other sections of the manual.

- 1** Power off the system before installing or removing the tape drive to prevent the possibility of electrical shock or damage to the tape drive. Unplug the unit that contains – or is to contain – the tape drive from AC power to provide an added measure of safety.
- 2** Read, understand, and observe all label warnings.

- 3 The Pivoting Optical Servo (POS) uses a Class I laser product. This laser product complies with 29 CFR 1200 and 29 CFR 1910 as applicable on the date of manufacture.

**Warning:** If you open the tape drive chassis, you may become exposed to invisible laser emission which could be harmful if you are directly exposed to the beam.

---

## Handling

---

Damage to the tape drive can occur as the result of careless handling, vibration, shock, or electrostatic discharge (ESD). For more details about ESD, see [Electrostatic Discharge Protection](#).

**Caution:** Always handle the A-Series tape drive with care to avoid damage to the precision internal components. Hold the tape drive only by its sides. Never hold the tape drive by inserting fingers into the receiver area on the front of the tape drive. Damage to the receiver area may occur if you lift or carry it in this manner.

Follow these guidelines to avoid damage to the tape drive:

- Always observe prescribed ESD precautions.
- Keep the external tape drive in its anti-static bag until ready to install.
- Always use a properly fitted wrist strap or other suitable ESD protection when handling the tape drive.
- Hold the tape drive only by its sides.
- Do not bump, jar, or drop the tape drive. Use care when transporting the tape drive.
- Always handle the tape drive carefully and gently. A drop of ¼ inch onto a bench or desktop may damage a tape drive.
- Never place the tape drive so that it rests on its front bezel. Always gently place the tape drive flat, bottom side down, on an appropriate ESD-protected work surface to avoid the tape drive being accidentally knocked over.
- Do not pack other materials with the tape drive in its anti-static bag.
- Place the tape drive in the anti-static bag before placing it in a shipping container.
- Do not stack objects on the tape drive.

- Do not expose the tape drive to moisture.
- Do not place foreign objects inside the tape drive's receiver area.

---

## Electrostatic Discharge Protection

---

Several electrical components of the A-Series tape drive are sensitive to static electricity and electrostatic discharge (ESD). Even a static buildup or discharge that is too slight to feel can be sufficient to destroy or degrade a component's operation.

To minimize the possibility of ESD-related damage to the system, the drive's manufacturer strongly recommends using both a workstation anti-static mat and an ESD wrist strap. When correctly installed and properly used, these devices reduce the buildup of static electricity that might harm the system.

Observe the following precautions to avoid ESD-related problems:

- Leave the tape drive in its anti-static bag until you are ready to install it in the system.
- Always use a properly fitted and grounded wrist strap or other suitable ESD protection when handling the tape drive and observe proper ESD grounding techniques.
- Hold the tape drive only by its sides.
- Place the tape drive on a properly grounded anti-static work surface pad when it is out of its protective anti-static bag.
- Do not use the bag as a substitute for the work surface anti-static pad. The outside surface of the bag may not have the same anti-static properties as the inside surface. It could actually increase the possibility of ESD problems.
- Do not remove covers to use any test equipment to check components on the PCBAs. There are no user-serviceable components on the tape drive.

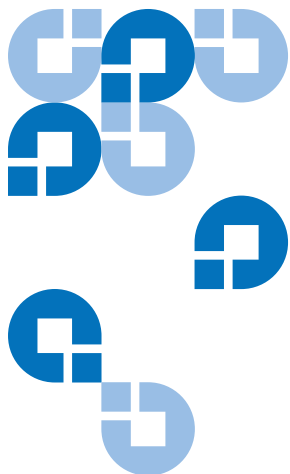

## Using Your Tape Drive

---

This chapter provides information about the LEDs and buttons on the front panels of the A-Series tape drives, A-Series data cartridges, formatting tape media cartridges, updating the firmware, cleaning the A-Series tape mechanism, and troubleshooting.

For information on the A-Series FTP file server, see the *Quantum A-Series FTP File Server User's Guide* (81-81800).

This chapter covers the following topics:

- [Front Panel LEDs and Tape Eject](#) describes the functionality of the front panel controls and LEDs.
- [A-Series Data Cartridges](#) provides information about write protecting, loading and unloading, and data cartridge care and maintenance.
- [Power On Self-Test \(POST\) Troubleshooting](#) provides basic troubleshooting information.

## Front Panel LEDs and Tape Eject

All LEDs are on the front panel of the A-Series tape drives along with the manual tape cartridge eject button. Use these LEDs to monitor the activity of your A-Series tape drive as necessary.

- [SDLT 600A](#)
- [LTO-3A](#)

### SDLT 600A

As shown in [figure 3](#), the SDLT 600A tape drive front panel display has three LED indicators that reflect the operating condition of the drive:

The left LED is dual color (green/orange). This LED is the density indicator. When you insert a Super DLTtape II data cartridge, this LED illuminates green.

[Table 2](#) describes control and LED functionality.

Figure 3 SDLT 600A Front Panel Display

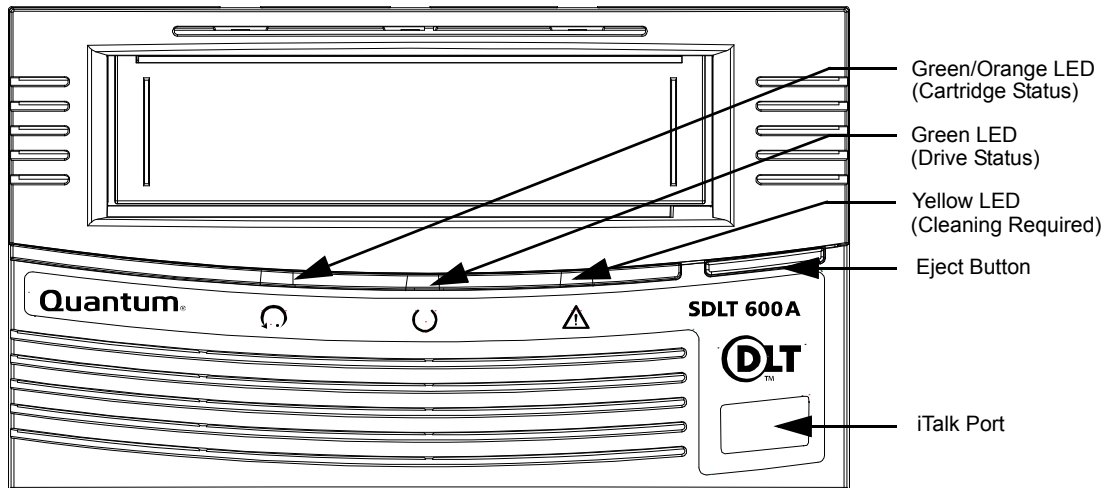





Table 2 SDLT 600A LED  
Codes

| LED/Button/<br>Port Title | Color/<br>Symbol   | Action     | Explanation  |
|---------------------------|--|------------|--|
| All LEDs                  | All LEDs illuminate briefly and then illuminate in sequence until the reset completes        |            | SDLT 600A tape drive reset   |
| No LED                    | No LEDs illuminate   |            | No data cartridge is inserted  |
| Cartridge Status LED      | Green<br>   | Remains On | Super DLTtape II data cartridge ejected  |
|                           |  | Remains On | Blank Super DLTtape II data cartridge inserted   |
|                           |  | Remains On | SDLT 600A tape drive formatted Super DLTtape II data cartridge inserted  |
| Cartridge Status LED      | Orange<br>  | On/Off     | Incorrect cartridge inserted   |
| Drive Status LED          | Green<br> | Flashing   | The tape drive is in use. This includes functions such as: <ul style="list-style-type: none"> <li>• The tape is moving.</li> <li>• The tape drive is calibrating, reading, writing, or rewinding the tape.</li> <li>• The tape drive is loading, unloading, or rewinding.</li> </ul> |
|                           |  | On         | The tape drive is idle. There may or may not be a data cartridge in the tape drive.  |
|                           |  | Off        | The tape drive has not been powered on or is not plugged into a power source.  |

| LED/Button/<br>Port Title         | Color/<br>Symbol  | Action | Explanation  |
|-----------------------------------|---|--------|--|
| Cleaning<br>Required LED          | Yellow<br> | On     | Cleaning is required. See <a href="#">Cleaning the Tape Mechanism</a> for cleaning information.  |
|                                   |   | Off    | Cleaning is not required.  |
| Eject Button                      |   | Press  | Use the <b>Eject</b> button to eject the tape data cartridge from the tape drive. When you press the button, the tape drive completes any active writing of data to the tape, then ejects the data cartridge.<br><br><b>Note:</b> A tape cartridge can be unloaded during an active FTP session only by using the built-in FTP client. Right-click within the right pane of the FTP client window to display the <b>Contextual</b> menu, then click <b>Eject tape</b> .<br><br>See the applicable data cartridge appendix for detailed data cartridge handling procedures. |
| Infrared<br>Communication<br>Port |   |        | This infrared port, also known as iTalk, provides a wireless remote testing base for customers and integrators to access system diagnostic information. See your Quantum sales representative for more information.  |

**Note:** Whenever the tape drive resets, all LEDs illuminate briefly and then illuminate in sequence until the reset completes. Whenever the tape drive encounters an error, all LEDs flash together.

---

**LTO-3A**

---

As shown in [figure 4](#), the LTO-3A tape drive front panel display has four LED indicators that reflect the operating condition of the drive:

The green **POWER** LED is on whenever power is applied to the drive.

The green **ACTIVITY** LED, the orange **ERROR** LED, and the amber **STATUS** LED are either on steady or blinking at different rates in various combinations to indicate the various drive conditions as shown in [table 3](#).

---

Figure 4 LTO-3A Front Panel Display

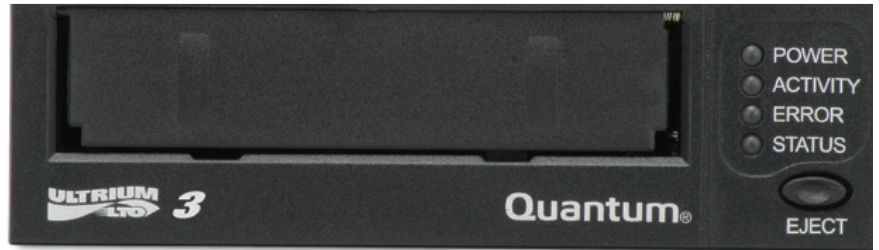

In [table 3](#):

| This indication . . . | Signifies that the LED is . . .                          |
|-----------------------|--|
| On                    | illuminated continuously in a steady state.              |
| Slow                  | blinking on and off at a rate of one cycle per second.   |
| Fast                  | blinking on and off at a rate of four cycles per second. |



Table 3 LTO-3A LED Codes

| <b>Drive Condition</b>  | <b>Activity LED (Green)</b> | <b>Error LED (Orange)</b> | <b>Status LED (Amber)</b> |
|---|-----------------------------|---------------------------|---------------------------|
| Cleaning Request  |                             |                           | On                        |
| Cleaning cartridge present  | On                          |                           | On                        |
| Cleaning cartridge at EOT   | On                          |                           | Fast                      |
| Cleaning failure or media error                                   |                             | Fast                      | Fast                      |
| Hardware error  |                             | Fast                      |                           |
| Manual intervention required                                      |                             | On                        |                           |
| Microcode download  | Fast                        | Slow                      | Fast                      |
| Microcode download error  | Fast                        | Fast                      | Fast                      |
| Positioning - loading, unloading, rewinding, spacing, or locating | Slow                        |                           |                           |
| Power On Self Test (POST) in progress                             | Slow                        | Slow                      | Slow                      |
| Power On Self Test (POST) failure                                 |                             | Fast                      | On                        |
| Servo initialization  | Slow                        |                           | Slow                      |
| Tape Active - writing, reading, or verifying                      | Slow                        |                           |                           |

## A-Series Data Cartridges

By following general handling procedures, conducting careful visual inspections of data cartridges on a regular, ongoing basis, and being certain to store data cartridges within their environmental limits, you will greatly reduce any chance that you will experience problems with your data cartridges or cause damage to your A-Series tape drive.

Please refer to [Appendix B](#) for further information about data cartridges.

**Note:** Always remove the data cartridge from the drive prior to powering down the drive. This ensures that the file system stored on the tape is consistent and that the tape in the tape path is not damaged when the unit is powered up.

### Write-Protect Switch

Each data cartridge has a write-protect switch that you can use to prevent accidental erasure of data. Before inserting the data cartridge into the tape drive, position the write-protect switch on the front of the data cartridge according to the type of operations you expect to perform.

### Write Protecting a SDLT 600A Data Cartridge

The Super DLTtape II data cartridge is dark blue and has a keying feature that prevents insertion into the older generation DLT tape drives, as shown in [figure 5](#).

Figure 5 Super DLTtape II Data Cartridge

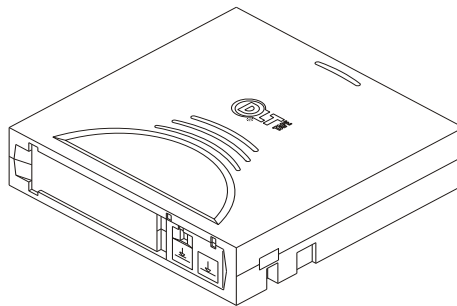

**Note:** The Super DLTtape II data cartridge has a keying feature to ensure you cannot load it into a previous generation DLT tape drive.

Figure 6 Write-protect Switch on Super DLTtape II Data Cartridge

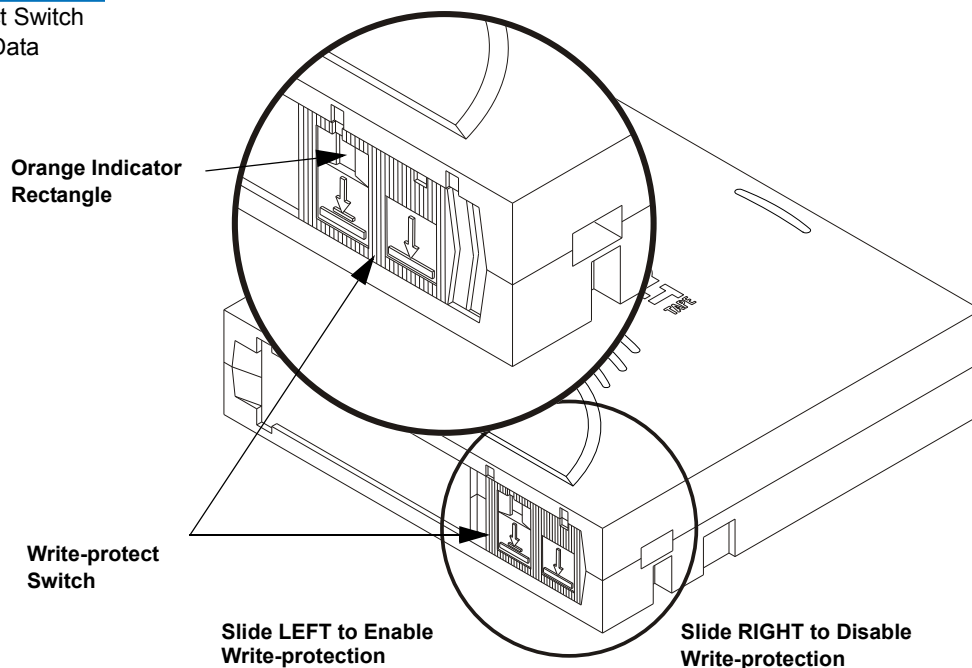

- Slide the write-protect switch to the left to *enable* write protection (you can read existing data; however, you cannot write over existing data on the media, nor append additional data to the media). When you move the write-protect switch to the left, a small orange rectangle is visible. This is your visual reminder that you cannot write data to the media.
- Slide the write-protect switch to the right to *disable* write protection (you can write over existing data on the media, and you can append additional data to the media unless the data cartridge is write-protected via firmware). When write-protection is disabled, no orange rectangle is visible.

## Write Protecting an Ultrium Data Cartridge

Ultrium tape cartridges have a sliding write-protect switch at the right-rear corner as shown in [figure 7](#).

| Sliding the write-protect switch toward the . . . | Enables data to be . . .  |
|---|---|
| center of the cartridge (the Locked position),    | read from the cartridge, but not written to it. (This is the write-protected position.) |
| corner of the cartridge (the Unlocked position),  | both read from and written to the cartridge. (This is the write-enabled position.)      |

Figure 7 Write-protect Switch on Ultrium Data Cartridge

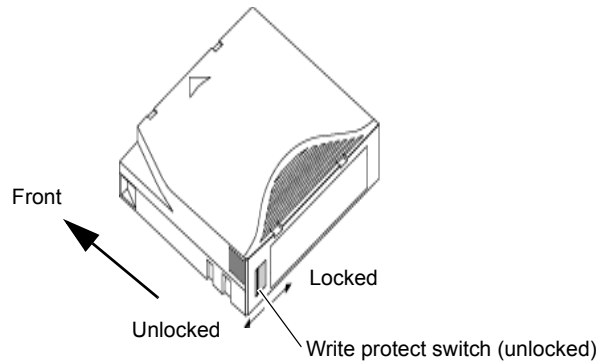

## Loading a Data Cartridge

To load a data cartridge into the front of the A-Series tape drive:

- 1 Insert the data cartridge into the front of the tape drive, as shown in [figure 8](#).
- 2 Push the data cartridge into the tape drive until the drive senses the cartridge and automatically completes the load operation.

The **Drive Status** LED flashes to show that the media is loading. When the media reaches the Beginning of Tape (BOT) marker, the LED lights steadily. The data cartridge is now ready for use.

Figure 8 Loading a Super  
DLTtape II Data Cartridge

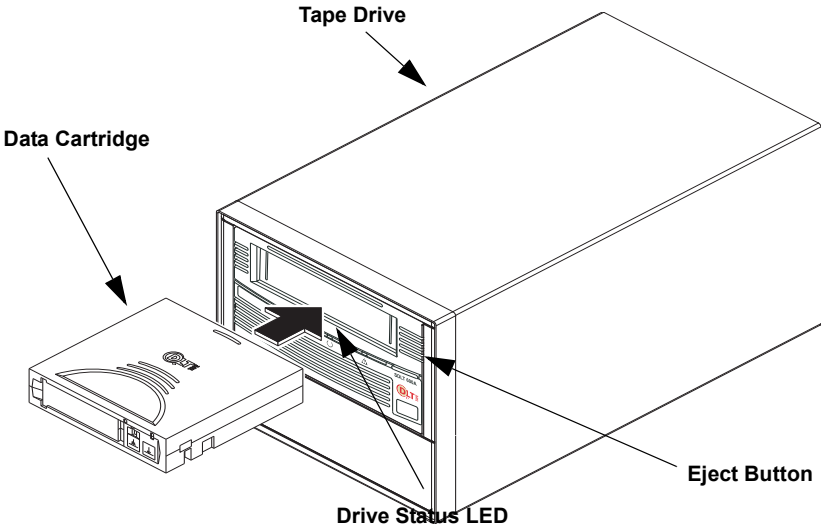

### Unloading a Data Cartridge

Follow these steps to unload a data cartridge:

- 1 Press the **Eject** button (or issue an appropriate system software command). The tape drive completes any active writing of data to the media, then rewinds. The **Drive Status** LED flashes as the media rewinds.

When the media is finished rewinding, the tape drive ejects the data cartridge and the **Drive Status** LED lights steadily.

**Note:** A tape cartridge can be unloaded during an active FTP session only by using the built-in FTP client. Right-click within the right pane of the FTP client window to display the **Contextual** menu, then click **Eject tape**.

**Caution:** Eject the data cartridge from the tape drive *before* turning off host power. Failure to remove a data cartridge may result in data cartridge or tape drive damage.

- 2 Remove the data cartridge from the tape drive and return the data cartridge to its plastic case to protect it from damage.

---

## Data Cartridge Care and Maintenance

---

Observe the following precautions to protect your data:

|                |  |
|----------------|--|
| <b>Always:</b> | <ul style="list-style-type: none"><li>• Remove the cartridge from the drive when not in use and store it in its protective case.</li><li>• Avoid dropping the cartridge. This can damage components inside the cartridge, possibly rendering the tape unusable. If you drop a tape cartridge, open the cartridge door and make sure that the leader pin is in the correct position.</li><li>• Re-tension a dropped cartridge before using.</li><li>• Keep the cartridge away from:<ul style="list-style-type: none"><li>• Direct sunlight and heat sources, such as radiators, heaters, or warm air ducts.</li><li>• Sources of electromagnetic fields, such as telephones, computer monitors, dictation equipment, mechanical or printing calculators, motors, magnetic tools, and bulk erasers.</li></ul></li></ul>  |
| <b>Do not:</b> | <ul style="list-style-type: none"><li>• Expose the cartridge to dirt, dust or moisture.</li><li>• Touch the tape media within the cartridge.</li><li>• Bulk erase Ultrium tape cartridges. LTO tape cartridges have prewritten servo patterns that cannot be reformatted by the tape drive. A bulk erase operation would make them unusable.</li><li>• Use tape cartridges outside the specified operating conditions: 10° C to 40° C, 20% to 80% relative humidity.</li></ul> <p>If a tape cartridge has been exposed to conditions outside the specified range, recondition the tape before using in the operating environment by exposing it to the operating environment for a time equal to or greater than the time it was outside the operating environment, up to a maximum of 24 hours. Then re-tension the tape to stabilize the tape pack for better performance.</p> |

## Power On Self-Test (POST) Troubleshooting

This section provides troubleshooting information that might be helpful should the system fail its power on self-test (POST).

See the data cartridge appendices in this document ([Data Cartridges](#)) for complete visual inspection instructions for Super DLTtape II data cartridges.

The Web site [www.dlftape.com](http://www.dlftape.com) also includes valuable information about SDLT systems.

### POST Operation

The A-Series tape drive performs a power on self-test (POST) each time the tape drive is powered on. POST normally completes in 10 to 15 seconds – when a data cartridge is not in the tape drive – when the unit is powered on. However, if a data cartridge is in the tape drive when the unit is powered on, POST duration is longer, depending on how much tape in the data cartridge may be loaded in the tape drive.

See [Front Panel LEDs and Tape Eject](#) to help familiarize yourself with the LEDs on the front panel.

For the SDLT 600A tape drive, Stage 3 in the following table provides the sequence of operations to expect when power is turned on.

Table 4 LED Lighting Pattern During Power-On Self-Test (POST)

| Stage        | What You Observe   |
|--------------|--|
| 1 (Power On) | All LEDs illuminate for approximately one second.  |
| 2            | The LEDs flash on, then off in a progressing pattern from left to right. Stages 1 and 2 generally complete within approximately five seconds.                  |
| 3            | The right LEDs remain off, the left LED illuminates steadily, and the middle LED flashes until POST completes. This stage typically lasts for 5 to 10 seconds. |

| Stage  | What You Observe   |
|--|--|
| 4  | When POST is complete, the middle LED stops flashing and remains illuminated; the left LED turns off, and right LED remains off. |
| POST Failure   | If POST fails, the middle and right LEDs illuminate steadily and the left LED flashes.   |
| <p><b>Note:</b> If a data cartridge is in place when power is turned on, all stages remain the same except Stage 3. It may take a considerably longer time for Stage 3 to complete due to tape rewind and searching operations that occur during that stage.</p> |  |

Figure 9 SDLT 600A Tape Drive Front Panel LEDs

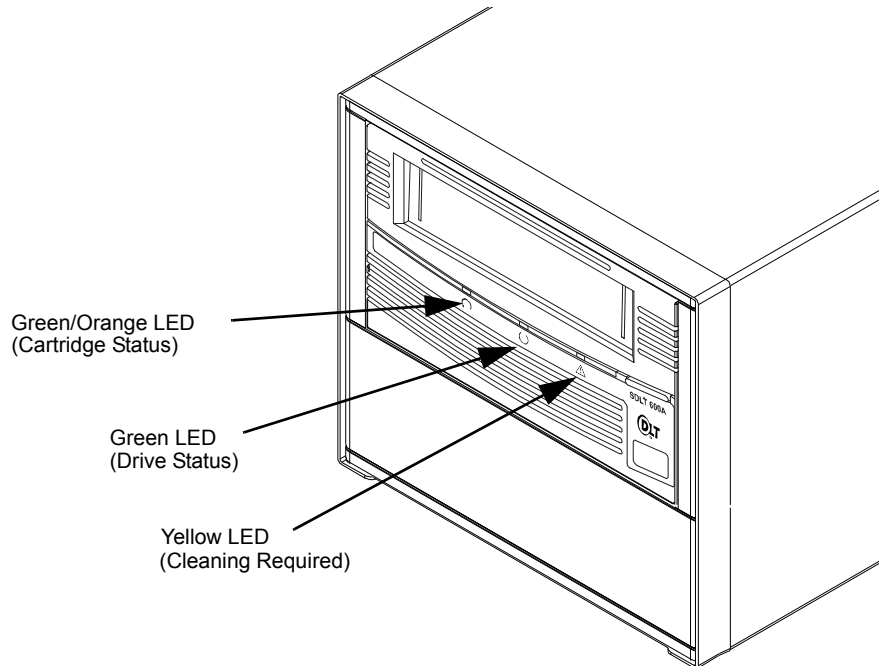



## POST Troubleshooting Tips

[Table 5](#) provides troubleshooting tips that you will find useful in the event that your tape drive fails its POST.

If, after attempting the recommended actions listed in the table, the problem still exists or recurs, a hardware failure may be the cause. Contact your service representative.

Table 5 Troubleshooting Chart

| If...  | Then...   | You should...  |
|--|---|--|
| The system does not recognize the tape drive.      | Host computer may not be configured to recognize the network. | Configure system to recognize the tape drive's ID.   |
|  | Network/IP parameters may not be correct.                     | Configure network/IP parameters.   |
|  | Network cable may be loose.                                   | Ensure that the network cable is fully seated at each connector end.                           |
| The tape drive does not power on.                  | No power is reaching the tape drive.                          | Check the tape drive's power cable connection at the back of the system.                       |
| You are experiencing reduced drive transfer rates. | Check your operating environment (host PC) and cabling.       | Update the cable to CAT-5E or CAT-6. If the problem persists, please contact customer support. |

---

### Over Temperature Condition

---

The tape drive has a thermal sensor located in the tape path. This sensor, which is used to accurately monitor the air temperature in the tape path, issues a TapeAlert warning at 47 degrees C, and detects an overtemp condition when the temperature in the tape path reaches 50 degrees C. When the tape path temperature sensor detects an overtemp condition, the tape rewinds, unloads, and ejects from the tape drive. (As long as the tape drive is not mounted in a tape automation library, the tape ejects.)

If the tape drive is mounted in a tape automation library, the data cartridge rewinds to BOT and unbuckles in preparation for unloading, but does not automatically eject.

---

### Frequently Asked Questions

---

For the latest FAQs, go to [www.quantum.com](http://www.quantum.com) and click **Knowledgebase/FAQs** under **Service and Support**.

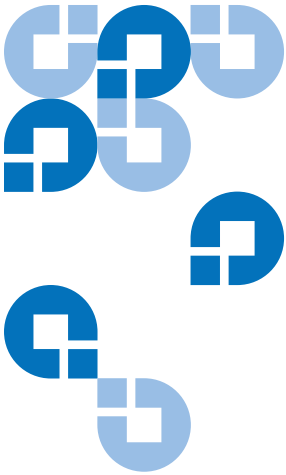

## Appendix A Specifications

---

This appendix describes the technology behind the drives as well as the various specifications that apply to the A-Series tape drives.

- [A-Series SDLT 600A Tape Drive](#)
- [A-Series LTO-3A Tape Drive](#)

This chapter describes the technology behind the drives as well as the various specifications that apply to the Quantum A-Series Tape Drives.

A Gigabit Ethernet (GigE) interface allows the drive to be quickly connected and accessed on your network.

The built-in FTP client or a standard FTP client can be used to store and retrieve MXF (Material Exchange Format) files to (and from) tape.

---

# A-Series SDLT 600A Tape Drive

The SDLT 600A tape drive incorporates various new state-of-the-art technologies that contribute to the SDLT architecture. Some of these ideas are trademarked, others are patented. The following subsections introduce the important technologies that together, comprise the SDLT 600A tape drive.

---

## Laser Guided Magnetic Recording

---

The SDLT 600A tape drives are based on Laser Guided Magnetic Recording (LGMR) technology. LGMR provides a unique combination of the best optical and magnetic technologies, which results in dramatically higher capacities by substantially increasing the number of recording tracks on the data-bearing surface of the media. By recording data magnetically on the data-bearing side of the media and using servo movement optically on the backside, LGMR optimizes highly proven technologies to deliver the most efficient, reliable, and scalable data retrieval solution to the mid-range market.

---

## Pivoting Optical Servo

---

Pivoting Optical Servo (POS) is a Quantum-invented, optically-encoded servo system, that combines high-density magnetic read/write data recording with laser servo guiding. The POS provides high-duty-cycle applications, which decreases cost and increases user convenience. The POS enables the head to track dynamic variations in tape motion which allows Quantum to provide a track count with an order of magnitude increase over previous products.

---

## Magneto Resistive Cluster Heads

---

Magneto Resistive Cluster (MRC) heads are a densely packed array of small, cost-effective Magneto Resistive (MR) tape heads precisely positioned using advanced thin-film processing technology. SDLT MRC heads provide high wafer usage efficiency resulting in low head costs, are less susceptible to variations in tape speed, yield higher track density and capacity, and provide a multi-channel architecture for increased transfer rate and performance.

---

**Advanced Partial  
Response Maximum  
Likelihood**

---

Improving on Partial Response Maximum Likelihood (PRML) technology traditionally used in disk drives and communication systems, advanced PRML channel technology, co-developed with Lucent Technologies, brings new levels of performance and capacity to high-performance linear tape products. This provides high-encoding efficiency recording densities for greater capacity and performance that enables SDLT to increase transfer rates and capacity substantially.

---

**Advanced Metal Powder  
Media**

---

Advanced Metal Powder (AMP) media is a state-of-the-art media using durable metal powder technology for recording very high densities of data. The back side of the AMP media receives a specially formulated coating to accept the optical servo tracks. Because the servo information is on the back side of the media, the entire data-bearing side of the media is available for recording data and eliminates the need for pre-formatting. In addition, AMP media meets the needs of multiple generations of the SDLT technology.

---

**Positive Engagement  
Tape Leader Buckling  
Mechanism**

---

The positive engagement tape leader buckling mechanism is a highly robust mechanism that increases data cartridge life and supports the extensive duty-cycle environments found in high-end and automation environments.

This mechanism engages the tape leader upon data cartridge load and disengages it upon data cartridge unload. It uses a solid metal pin attached to the drive leader to link with molded clips permanently attached to the tape leader inside the data cartridge. The Positive Leader Link design makes the buckling of Super DLT tape media a totally reliable mechanical process.

---

## Modular Design

The SDLT 600A tape drive is designed as a total system. The system includes a complex interaction of a number of important components including such items as the tape path, tape heads, media, data cartridge, and host interface.

As shown in [figure 10](#), the SDLT 600A tape drive consists of five distinct modules:

- Data Control Module (DCM)
- Tape Control Module (TCM)
- Front Panel Module (FPM)
- Electronic Interface Module (EIM)
- Super DLTtape II Data Cartridge (Data Cartridge).

The modular concept makes the SDLT 600A tape drive easy to manufacture and configure. Each module is optimized to perform a specific set of functions and designed to interface with the other modules in a well defined and flexible manner.

The following subsections provide a brief overview of each module.

Figure 10 SDLT 600A Tape Drive Modular Design

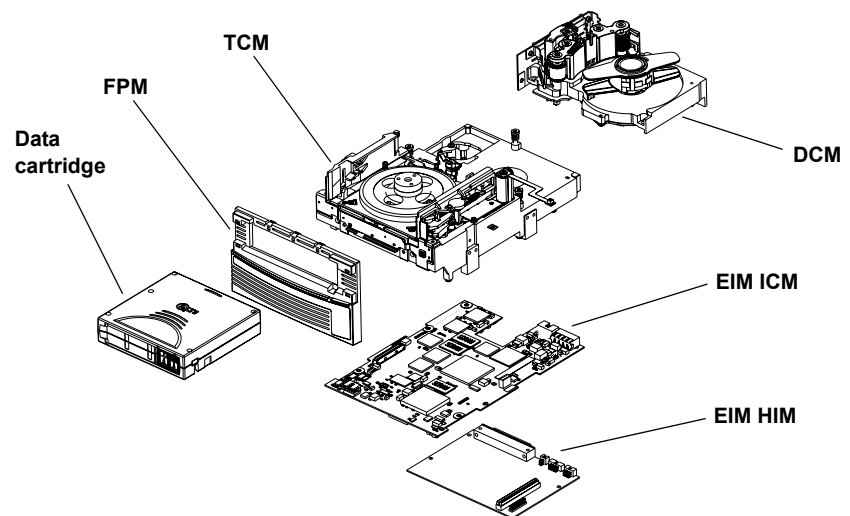

**Note:** Despite the deliberate modularity of each module, with the exception of the FPM, individual users should not **swap** modules. The FPM is the only module that is field replaceable. Customer adjustments to the TCM, DCM, or EIM will void the tape drive's warranty.

---

## Data Control Module

---

The Data Control Module (DCM) contains several of the functions and features of LGMR technology, which is at the heart of the SDLT technology. Of the five technologies that constitute the LGMR technology, two are in the DCM. These are the POS and the MRC heads.

The main functions of the DCM are to provide the path and guides for all tape motion inside the tape drive and to write data to and read data from the tape. In addition to the POS and MRC heads described in [Pivoting Optical Servo](#) and [Magneto Resistive Cluster Heads](#), the DCM contains a number of components that interact to perform these functions. These components include:

- Advanced head guide assembly
- Take-up reel
- Drive motor
- Optical servo system
- Tape heads.

In addition to its mechanical components, the DCM also contains printed circuit boards that control the functions of the DCM and the tape heads.

---

## Tape Control Module

---

The Tape Control Module (TCM) implements the functions required to buckle and unbuckle the tape and control the tape motion. The TCM consists of a variety of components:

- TCM Printed Circuit Board Assembly (PCBA)
- Base Plate
- Data Cartridge Receiver
- Positive Engagement Tape Leader Buckling Mechanism
- Tape supply motor assembly
- Floor plate assembly.

### TCM PCBA

The TCM has its own PCBA that controls the functions of the TCM and interfaces with the main controller board in the EIM. By designing the TCM as a distinct module, it allows manufacturing and testing the TCM

as a stand-alone module, simplifying the design, manufacturing, and troubleshooting processes.

### **Base Plate**

The SDLT 600A tape drive base plate is an aluminum die casting with precisely machined surfaces. The casting acts as the support platform for the other modules and for the tape drive enclosure. The base plate also includes the precision mounting holes used to install SDLT 600A tape drives into a server or tape library. The SDLT 600A tape drive base plate, and therefore the entire SDLT 600A tape drive, conforms to the 5.25 inch, full-height form factor.

### **Data Cartridge Receiver**

On tape insertion, the data cartridge receiver assembly guides the tape into its operating position, opens the data cartridge door, unlocks the data cartridge brakes, engages the data cartridge drive motor, and secures the tape for operation. On tape ejection, the data cartridge receiver assembly reverses the process and automatically ejects the tape a fixed distance from the front of the tape drive.

### **Positive Engagement Tape Leader Buckling Mechanism**

The buckling mechanism is responsible for engaging the tape leader upon data cartridge load and disengaging it on data cartridge unload. See [Positive Engagement Tape Leader Buckling Mechanism](#) on page 29 for more information.

---

### **Front Panel Module**

---

The Front Panel Module (FPM) of the system (sometimes referred to as the bezel) performs a number of functions:

- Protecting the front of the TCM from physical damage
- Channeling airflow through the system
- Aligning the data cartridge when it is inserted into the system
- Providing system status and information through LEDs
- Enabling data cartridge ejection



- Delivering the overall cosmetic look of the system.

The FPM is a single module with lenses for the system's LEDs and a button to activate the drive eject switch. The SDLT 600A tape drive front panel contains no electronics.

---

## Electronic Interface Module

---

The Electronic Interface Module (EIM) is the electronic heart of the tape drive. It provides the main control function for the system and the interface from the system to the host computer, library, or autoloader. The EIM provides the Advanced PRML feature of Quantum's SDLT technology. See [Advanced Partial Response Maximum Likelihood](#) on page 29 for a brief description of PRML.

The EIM consists of two major boards: the Integrated Controller Module (ICM), and a separate Host Interface Module (HIM), see [figure 10](#). The ICM contains the main controller and servo microprocessor, the custom-designed SDLT ASICs, and the cache memory while the HIM implements the interface between the host system and the tape drive. This allows easy configuration of the tape drive to match different host interfaces by simply substituting the appropriate HIM card.

As with the other major modules of the SDLT technology, the EIM is manufactured and tested as a distinct module.

---

## Super DLTtape II Data Cartridge

---

As with all tape technologies, the Super DLTtape II data cartridge is a key part of the overall system. The main function of the data cartridge is to provide the magnetic recording media used by the system to store customer information. The data cartridge also provides the protective casing that allows safe media movement and storage.

From the outside, the Super DLTtape II data cartridge looks very similar to the Super DLTtape I and DLTtape VS1 data cartridges. The basic geometry, write protection switch, and label space are the same. This simplifies the integration of the SDLT 600A tape drive into existing operating environments and into automated tape libraries. The Super DLTtape II data cartridge is easy to recognize; it has a different color than the Super DLTtape I and DLTtape VS1 data cartridges, and contains a distinctive pattern molded into the shell. The DLTtape logo and the product name are also molded into the shell, which ensure you have a genuine Quantum Super DLTtape II data cartridge.

## Product Specifications

The following subsections contain product specifications for the SDLT 600A tape drive.

### Positive Engagement Tape Leader Buckling Mechanism

This buckling mechanism engages the tape leaders upon data cartridge load and disengages them upon data cartridge unload.

Component level tests of buckle arm components have shown at least 250,000 cycles on the tape drive without failure, breakage, or binding; this includes the take-up leader, the supply leader, and the media itself.

## Functional Specifications

The following subsections contain functional specifications for the SDLT 600A tape drive.

### Performance Data

[Table 6](#) provides performance data for the tape drive.

Table 6 SDLT 600A Tape Drive Performance Data

| Item                            | Specification                            |
|---------------------------------|--|
| Drive Read/Write Transfer Rate* | 36 MB/second, native                     |
| Maximum Throughput*             | 11 MB/second, native                     |
| Tracks                          | 40 logical tracks<br>640 physical tracks |
| Track Density                   | 1502 tracks per inch (tpi)               |
| Linear Bit Density              | 233 Kbits per inch (Kbpi)                |
| Read/Write Tape Speed           | 108 inches per second (ips)              |

| Item                             | Specification   |
|----------------------------------|---|
| Rewind Tape Speed                | 160 ips   |
| Linear Search Tape Speed         | 160 ips   |
| Average Rewind Time**            | 77 seconds  |
| Maximum Rewind Time**            | 156 seconds   |
| Average Access Time** (from BOT) | 79 seconds  |
| Maximum Access Time** (from BOT) | 190 seconds   |
| Load to BOT**                    | 18 seconds (typical)<br>63 seconds (unformatted tape)             |
| Unload from BOT**                | 19 seconds  |
| Nominal Tape Tension             | Stationary: $3.0 \pm 0.5$ oz<br>Operating Speed: $3.5 \pm 0.5$ oz |

\* Depending on data type and Ethernet network connection configuration. GigE is required for 36 MB/s.

\*\* Note that data is typical; times may be longer if error recovery time is necessary, or if the command times out for any reason.

## Shock and Vibration Specifications

The following tables provide non-operating and operating shock and vibration specifications for the SDLT 600 tape drive.

Table 7 Non-operating Shock Specifications (Unpackaged)

| Shock (Unpackaged) |                           |              |
|--------------------|---------------------------|--------------|
| Pulse Shape        | Square wave               | ½ sine pulse |
| Peak Acceleration  | 40 G                      | 140 G        |
| Duration           | 10 ms (180 inches/second) | 2 ms         |

**Shock (Unpackaged)**

|             |   |
|-------------|---|
| Application | X,Y,Z axes, twice in each axis (once in each direction) |
|-------------|---|

Table 8 Non-Operating Shock Specifications (Packaged, Drop)

| <b>Shock (Packaged, Drop)</b> | <b>Height of Drop</b> | <b>Number of Drops</b> | <b>Package Weight</b>              |
|-------------------------------|-----------------------|------------------------|------------------------------------|
| Drop                          | 42 inches             | 16 drops total         | 0 lbs. < package weight ≤ 20 lbs.  |
|                               | 36 inches             | 16 drops total         | 20 lbs. < package weight ≤ 50 lbs. |

Table 9 Non-Operating Vibration Specifications (Unpackaged)

**Vibration (Unpackaged)**

| <b>Type</b>        | <b>Sine</b>              | <b>Sweep</b>   |
|--------------------|--------------------------|--|
| Frequency Range    | 5 to 500 to 5 Hz         | Upward and downward sweep  |
| Acceleration Level | 0.02" DA<br>1.0 G        | Between 5 and 31 Hz (crossover)<br>Between 31 and 500 Hz (crossover) |
| Application        | X,Y,Z axes               | Sweep rate = ½ octave/minute   |
| <b>Type</b>        | <b>Random</b>            |  |
| Frequency Range    | 10 to 500 Hz             |  |
| Acceleration Level | 2.0 G                    |  |
| PSD Envelope       | 0.008 G <sup>2</sup> /Hz |  |
| Application        | X,Y,Z axes               | Sweep rate = 60 minutes/axis   |

Table 10 Non-Operating  
Vibration Specifications  
(Packaged)

| <b>Vibration (Packaged)</b> |   |
|-----------------------------|---|
| <b>Type</b>                 | <b>Random</b>   |
| Frequency Range             | Truck Profile* (0.5 Grms)<br>Air Profile* (1.0 Grms)  |
| Application                 | X,Y,Z axes (30 minutes, each profile and each axis, for a total of 3 hours)   |
| <b>Type</b>                 | <b>Sine, Sweep, and Dwell</b>   |
| Frequency Range             | 5 to 150 to 5 Hz; 0.5 octave/minute, 0.5 G  |
| Application                 | X,Y,Z axes; dwell at lowest resonant frequency in axis for 30 minutes. Additional 30 minutes for each additional resonance; up to 4 resonances total. |

\* Air and truck profiles are specified in ASTM D4728, Standard Test Method for Random Vibration Testing of Shipping Containers.

Table 11 Operating Shock and  
Vibration Specifications

| <b>Shock</b>       |   |   |
|--------------------|---|---|
| <b>Pulse Shape</b> | <b>½ sine pulse</b>                                     |   |
| Peak Acceleration  | 10 G  |   |
| Duration           | 10 ms   |   |
| Application        | X,Y,Z axes, twice in each axis (once in each direction) |   |
| <b>Vibration</b>   |   |   |
| <b>Type</b>        | <b>Sine</b>   | <b>Sweep</b>  |
| Frequency Range    | 5 to 500 to 5 Hz  | Upward and downward sweep                                   |
| Acceleration Level | 0.25 G<br>0.010" DA                                     | Between 22 and 500 Hz<br>Between 5 and 22 Hz<br>(crossover) |

---

**Shock**

---

|             |            |                                    |
|-------------|------------|------------------------------------|
| Application | X,Y,Z axes | Sweep rate = 1.0 octave/<br>minute |
|-------------|------------|------------------------------------|

---



---

**Current and Power Requirements**

---

The tape drive draws the highest current (and power) during the native write modes. *Standby* is measured with the tape loaded and tensioned or untensioned, and *Idle* is measured with power on with no tape loaded. (The power drawn in these two modes is similar enough that they are listed together.)

**Note:** In [table 12](#), the current and DC power values pertain to the internal tape drive, while the AC power values apply to the tabletop tape drive.

---

Table 12 Current Requirements — SCSI Interface

| Mode                                     | 5 V Current (A)    |                      |                  | 12 V Current (A)   |                      |                  | DC Power (W)     |                  | AC Power (W)     |                  |
|--|--------------------|----------------------|------------------|--------------------|----------------------|------------------|------------------|------------------|------------------|------------------|
|  | MaxPk <sup>1</sup> | MaxMean <sup>2</sup> | Typ <sup>3</sup> | MaxPk <sup>1</sup> | MaxMean <sup>2</sup> | Typ <sup>3</sup> | Max <sup>4</sup> | Typ <sup>5</sup> | Max <sup>6</sup> | Typ <sup>7</sup> |
| Standby/Idle                             | 2.5                | 2.5                  | 2.5              | 0.7                | 0.7                  | 0.7              | 2.5              | 2.5              | 2.5              | 0.7              |
| Media Loading/<br>Unloading              | 3.8                | 3.8                  | 3.4              | 2.2                | 2.1                  | 1.7              | 3.8              | 3.8              | 3.4              | 2.2              |
| 600A Write –<br>Motor Start <sup>8</sup> | 3.4                | 3.4                  | 3.3              | 2.0                | 1.2                  | 1.1              | 3.4              | 3.4              | 3.3              | 2.0              |
| 600A Write –<br>Streaming                | 3.7                | 3.7                  | 3.5              | 2.0                | 1.1                  | 1.1              | 3.7              | 3.7              | 3.5              | 2.0              |

| Mode  | 5 V Current (A)    |                      |                  | 12 V Current (A)   |                      |                  | DC Power (W)     |                  | AC Power (W)     |                  |
|---|--------------------|----------------------|------------------|--------------------|----------------------|------------------|------------------|------------------|------------------|------------------|
|   | MaxPk <sup>1</sup> | MaxMean <sup>2</sup> | Typ <sup>3</sup> | MaxPk <sup>1</sup> | MaxMean <sup>2</sup> | Typ <sup>3</sup> | Max <sup>4</sup> | Typ <sup>5</sup> | Max <sup>6</sup> | Typ <sup>7</sup> |
| Max for SDLT 600A tape drive Modes <sup>9</sup> | N/A                | 3.8                  | N/A              | N/A                | 2.1                  | N/A              | N/A              | 3.8              | N/A              | N/A              |

1. The Max-Peak value represents short current spikes drawn for durations of < 50ms. On the 12V supply, the peaks correspond to the pulse-width-modulated switching of the motors. These values are calculated from the average of Peak-ripple-current + 2 sigma, measured at nominal DC voltage.
2. The Max-Mean value is the average of the maximum RMS current drawn during this operating mode. These values are calculated from the average of RMS current + 3 sigma, measured at nominal DC voltage.
3. The typical current is calculated from the average of all RMS current drawn during this operating mode, measured at nominal DC voltage.
4. The Max DC power is calculated from the typical DC power + 3 sigma, measured at nominal DC voltage. This value takes into account that the peak currents on the 5V and 12V do not occur at the same time.
5. The Typical DC power is calculated from the average RMS DC power drawn during this operating mode, measured at nominal DC voltage. This value also takes into account that the peak currents on the 5V and 12V do not occur at the same time.
6. The Max AC power is calculated from the typical AC power in tabletop tape drives + 3 sigma.
7. The Typical AC power is calculated from the average of AC power drawn in tabletop tape drives.
8. These events last < 1 second and occur at a duty cycle of less than 25%.
9. The Max values for each mode are based on the Max-Mean values, since the peak values are of very short duration.

**(Common Notes)**

- (1) Voltage tolerance: 5V  $\pm$ 5%, 12V  $\pm$ 5%; Room temperature 24 °C. AC power measured at 117 V, 60 Hz.
- (2) DC Current, MaxMean, and DC/AC Power Max refer to the statistically calculated maximum average requirement based on a sample population of tape drives. These values do not reflect the peak current or power requirement; this amount is given by the DC MaxPk current.
- (3) These results were from the DVT data taken by Percept Technology. Reference the “Power Consumption & Characterization Test Report” dated 11/28/2005.
- (4) Test data set included 12 measurements: 3 measurements of 4 drives.
- (5) The 5V “MaxPK” calculated to less than MaxRMS, which does not at first glance make sense. (MaxPK is calculated at 5.25V, and the switching power supplies need less input current to the same input current.) Instead, the MaxRMS value was substituted.

Table 13 Power Requirements  
— SCSI Interface

| Mode  | DC Power           |                  | AC Power (W)     |                  |
|---|--------------------|------------------|------------------|------------------|
|   | MaxPk <sup>1</sup> | Typ <sup>2</sup> | Max <sup>3</sup> | Typ <sup>4</sup> |
| Standby/Idle                                    | 21                 | 21               | 51               | 46               |
| Media Loading/Unloading                         | 43                 | 37               | 83               | 73               |
| 600A Write - Motor Start <sup>5</sup>           | 32                 | 29               | 78               | 71               |
| 600A Write - Streaming                          | 32                 | 31               | 73               | 64               |
| Max for SDLT 600A tape drive Modes <sup>6</sup> | 43                 | N/A              | 83               | N/A              |

1. The Max-Peak value represents short current spikes drawn for durations of < 50ms. On the 12V supply, the peaks correspond to the pulse-width-modulated switching of the motors. These values are calculated from the average of Peak-ripple-current + 2 sigma, measured at nominal DC voltage.
2. The typical current is calculated from the average of all RMS current drawn during this operating mode, measured at nominal DC voltage.
3. The Max AC power is calculated from the typical AC power in tabletop tape drives + 3 sigma.
4. The Typical AC power is calculated from the average of AC power drawn in tabletop tape drives.
5. These events last < 1 second and occur at a duty cycle of less than 25%.
6. The Max values for each mode are based on the Max-Mean values, since the peak values are of very short duration.

**(Common Notes)**

- (1) Voltage tolerance: 5V  $\pm$ 5%, 12V  $\pm$ 5%; Room temperature 24 °C. AC power measured at 117 V, 60 Hz.
- (2) DC Current, MaxMean, and DC/AC Power Max refer to the statistically calculated maximum average requirement based on a sample population of tape drives. These values do not reflect the peak current or power requirement; this amount is given by the DC MaxPk current.
- (3) These results were from the DVT data taken by Percept Technology. Reference the “Power Consumption & Characterization Test Report” dated 11/28/2005.
- (4) Test data set included 12 measurements: 3 measurements of 4 drives.
- (5) The 5V “MaxPK” calculated to less than MaxRMS, which does not at first glance make sense. (MaxPK is calculated at 5.25V, and the switching power supplies need less input current to the same input current.) Instead, the MaxRMS value was substituted.



---

### SDLT 600A Tape Drive Recording Method

---

The SDLT 600A tape drive uses the Partial Response Maximum Likelihood (PRML) 32/33 encoding method for reading/writing SDLT 600A tape drive format. It uses the same algorithm for reading SDLT 220, SDLT 320, and the DLT VS160 tape drive formats.

---

## Environmental Specifications

The SDLT 600A tape drive operates in environments that include general offices and work spaces with systems capable of maintaining standard comfort levels.

The following subsections provide the environmental specifications for the SDLT 600A tape drives (both the internal and the tabletop configurations). For long-term trouble-free operation, the manufacturer strongly recommends that SDLT 600A tape drives be used in a clean, smoke-free environment.

---

### Air Flow Requirements

---

The internal tape drive requires adequate air flow to dissipate the heat resulting from continuous drive operation. Specifically, the air flow must be sufficient to keep the tape path temperature below 50 °C.

To allow enough air into the tape drive to keep the tape path below this temperature, it is important to keep the cooling holes in the rear and the grill in the front of the tape drive clear of any obstructions that may hinder the air flow.

**Note:** It is also important to limit the ambient air temperature to no greater than 40 °C.

---

### Temperature and Humidity

---

The ambient operating environment for the tape drive may not exceed the limits shown in [table 14](#).

Table 14 Temperature and Humidity Specification

| Specification              | Operating Limits                     | Non-Operating Limits (Power On, No Tape Loaded) |
|----------------------------|--------------------------------------|---|
| Wet Bulb Temperature       | 25 °C (77 °F)                        | 25 °C (77 °F)                                   |
| Dry Bulb Temperature Range | 10 °C to 40 °C<br>(50 °F to 104 °F)  | 10 °C to 40 °C<br>(50 °F to 104 °F)             |
| Temperature Gradient       | 11 °C (20 °F)/hour<br>(across range) | 15 °C (27 °F)/hour<br>(across range)            |
| Relative Humidity          | 20% to 80%<br>(non-condensing)       | 10% to 90%<br>(non-condensing)                  |
| Humidity Gradient          | 10%/hour                             | 10%/hour  |

## Storage and Shipment

The ambient storage and shipment environment for the tape drive may not exceed the limits shown in [table 15](#).

Table 15 Tape Drive Storage and Shipment Specifications

| Specification*       | Storage (Unpacked or Packed)          | Shipping                              |
|----------------------|---------------------------------------|---------------------------------------|
| Wet Bulb Temperature | 46 °C (114 °F)                        | 46 °C (114 °F)                        |
| Dry Bulb Temperature | -40 °C to 66 °C<br>(-40 °F to 150 °F) | -40 °C to 66 °C<br>(-40 °F to 150 °F) |
| Temperature Gradient | 20 °C (36 °F)/hour<br>(across range)  | 20 °C (36 °F)/hour<br>(across range)  |
| Relative Humidity    | 10 to 95%<br>(non-condensing)         | 10 to 95%<br>(non-condensing)         |
| Humidity Gradient    | 10%/hour                              | 10%/hour                              |

**Note:** These specifications apply to the tape drive only. Media specifications are listed in [Recording Media Specifications](#) on page 43.

---

**Altitude**

---

Both the internal and tabletop tape drives operate in normal pressures from -500 to 10,000 feet when operated within the ambient operating environments specified in [Temperature and Humidity](#) on page 41.

The SDLT 600A tape drive will operate to 30,000 feet for temperatures within  $15 \pm 5$  °C.

---

## Recording Media Specifications

Super DLTtape II media differs slightly from previous generations of Super DLTtape media. [Table 16](#) shows overall specifications for Super DLTtape II media.

---

Table 16 Super DLTtape II  
Media Specifications

| Characteristic         | Specification |
|------------------------|---------------|
| Overall tape thickness | 8.0 µm        |
| Media length, total    | 2066 feet     |
| Media length, usable   | 1957 feet     |

---

**Media Structure**

---

Super DLTtape II media comprises several layers, as shown in [figure 11](#).

Figure 11 Multiple Layers  
Comprise Super DLTtape II  
Media

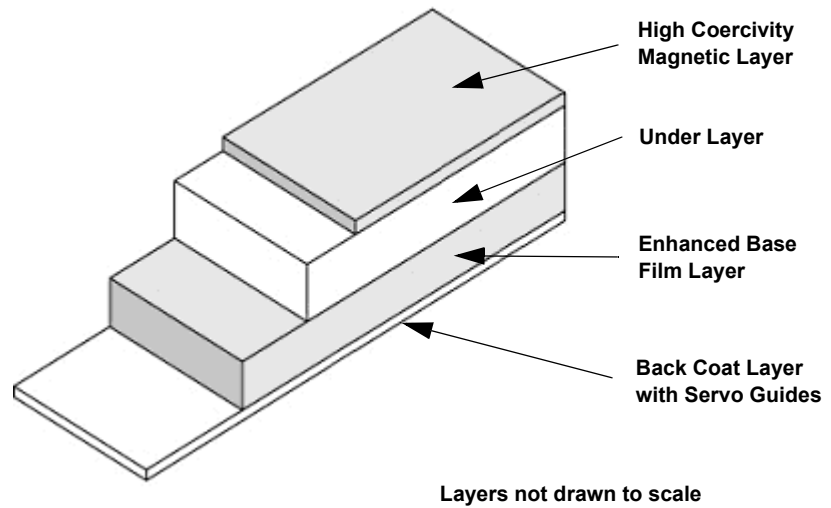

## Physical Data Cartridge

A durable plastic case encloses the Super DLTtape II media, as shown in [figure 12](#).

Figure 12 Super DLTtape II  
Data Cartridge

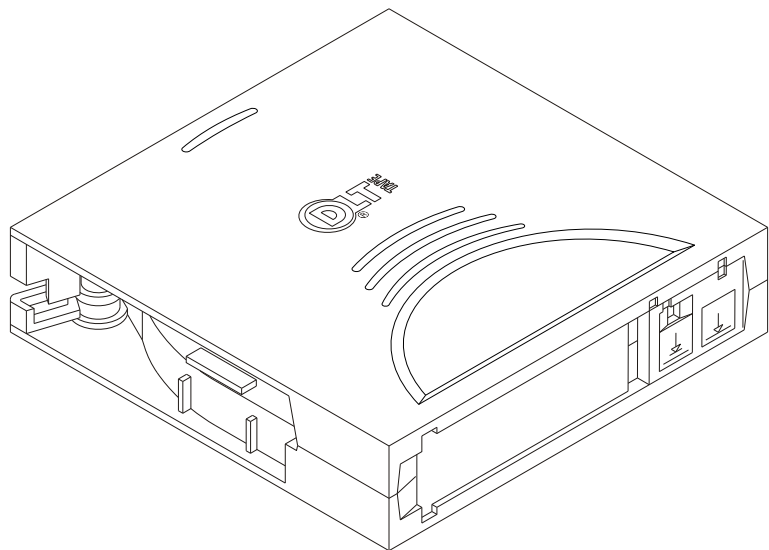

## Media Shipping, Operating, and Storage Specifications

The optimum media shipping conditions are described in [table 13](#).

Figure 13 Super DLTtape II  
Media Shipping Limits

| Shipping Conditions          |                                  |
|------------------------------|----------------------------------|
| Temperature                  | -18 °C to 49 °C (0 °F to 120 °F) |
| Relative Humidity            | 20 to 80% (non-condensing)       |
| Maximum Wet Bulb Temperature | 26 °C (79 °F)                    |
| Maximum Dew Point            | 2 °C (36 °F)                     |

Table 17 Super DLTtape II  
Media Operating Limits

| Operating Conditions |                                |
|----------------------|--------------------------------|
| Temperature          | 10 ° to 40 °C (50 ° to 104 °F) |
| Relative Humidity    | 20% to 80% (non-condensing)    |

[Table 18](#) describes the optimum media storage conditions.

Table 18 Super DLTtape II  
Media Storage Limits  
(Continued)

| Storage Conditions | Archival                         | Non Archival                     |
|--------------------|----------------------------------|----------------------------------|
| Temperature        | 18 ° to 28 °C<br>(64 ° to 82 °F) | 16 ° to 32 °C<br>(60 ° to 90 °F) |
| Relative Humidity  | 40% to 60%<br>(non-condensing)   | 20% to 80%<br>(non-condensing)   |

## A-Series LTO-3A Tape Drive

[Table 19](#) lists the physical specifications of the A-Series LTO-3A tabletop tape drive.

Table 19 LTO-3A Physical Specifications

| Dimension | Value                      |
|-----------|----------------------------|
| Width     | 6.88 inches<br>(174.75 mm) |
| Height    | 6.48 inches<br>(164.46 mm) |
| Depth     | 12.6 inches<br>(320 mm)    |
| Weight    | 14.0 lbs.<br>(6.35 kg)     |

## Power Specifications

The tabletop LTO-3A tape drive has a built-in automatic switching power supply, requiring 100 - 240 VAC input at 50/60 HZ.

Current draw is 0.4 - 0.6 amps.

## Drive Performance Specifications

[Table 20](#) lists the performance specifications of the LTO-3 Half-Height Tape Drive.

Table 20 Drive Performance Specifications

| Specification  | Value  |
|--|--|
| Average data access time (650-m tape) from BOW (beginning of wrap)     | 60 seconds   |
| Average rewind time (650-m tape)                                       | ≥ 51 seconds   |
| Max rewind time (650-m tape)   | ≤ 120 seconds  |
| Capacity<br>LTO Ultrium 3 (680 m)                                      | 400 Gbytes (native)  |
| Cartridge unload time (if Table of Contents does not require updating) | 25 seconds   |
| Read Table of Contents   | 30 – 90 seconds (depending on size)  |
| Error recovery   | Read-after-write Reed Solomon ECC (2 levels)   |
| Flux density   | 10249 cells per mm   |
| Head configuration   | 2 bumps<br>16 thin-film write heads per bump<br>16 MR read heads per bump<br>2 MR servo heads per bump |
| Maximum data access time (650-m tape) from BOW                         | 120 seconds  |

| <b>Specification</b>                 | <b>Value</b>                       |
|--------------------------------------|------------------------------------|
| Maximum rewind time<br>(650-m tape)  | ≤ 115 seconds                      |
| Recording density                    | 5,120 RLL-encoded ONEs per mm      |
| Recording format                     | Ultrium 16-channel (U-316)         |
| Recording method                     | 0, 13/11 RLL                       |
| Recording undetectable errors        | Less than 1 in $10^{27}$ data bits |
| Recording unrecoverable errors       | Less than 1 in $10^{17}$ data bits |
| Synchronous transfer rate<br>(burst) | 160 Mbytes per sec max             |
| Tape drive type                      | LTO (Ultrium)                      |
| Tape speed                           | Up to 4.53 meters per second       |
| Track density                        | 70 tracks per mm                   |
| Transfer rate (sustained)            | 68 Mbytes/second (max, native)     |



# Environmental Requirements

[Table 21](#) lists the environmental specifications of the LTO-3 Half-Height Tape Drive.

Table 21 Environmental Requirements

| Specification                         | Operational  | Non-operational   |
|---------------------------------------|--|---|
| Acoustic level idling (A-wt sum)      | 52 dBA maximum 5.0 LwA Bels  | –   |
| Acoustic level operational (A-wt sum) | 57 dBA maximum 5.5 LwA Bels  | –   |
| Airflow requirements                  | Internal: 9 CFM (front to back)  | N/A   |
| Altitude                              | max 10,000 feet MSL (at 25°C)  | 40,000 feet (power off)   |
| Humidity gradient                     | 10% per hour   | 10% per hour  |
| Relative humidity                     | 20% to 80% non-condensing  | 10% to 95% non-condensing   |
| Shock (1/2 sine wave)                 | 10 Gs peak, 11 msec  | 40 Gs peak, 11 msec   |
| Temperature                           | +50° to +104°F (+10° to + 40°C)  | –40° to +149°F (–40° to + 66°C)   |
| Thermal gradient                      | 11°C per hour (10-40°C)  | 11°C per hour (10-40°C)   |
| Vibration (sweep test)                | 0.005 inches DA (5-27 Hz)<br>0.20 G peak (27-1000 Hz)<br>Sweep rate 5-1000 Hz<br>1.0 octave per minute | 0.1 inches (5-14 Hz)<br>1.0 G (14-500 Hz)<br>1.0 octave per minute<br>2.0 G random (5-500 Hz) |

## Reliability Specifications

The LTO-3 Half-Height Tape Drive is designed for maximum reliability and data integrity. [Table 22](#) lists the reliability specifications.

Table 22 Reliability Specifications

| Specification                     | Description  |
|-----------------------------------|--|
| Cartridge load/unload             | 100,000 cartridge load/unload cycles (no thread)   |
| Error recovery and control        | <ul style="list-style-type: none"> <li>• Error correction code techniques (C1 and C2 ECC)</li> <li>• Read-after-write (RAW)</li> <li>• Error monitoring and reporting (error log)</li> <li>• Retry on</li> </ul> |
| Mean time between failures (MTBF) | 250,000 hours MTBF at 100% duty cycle: power applied and tape moving continuously (tabletop drive; 50,000 hours at full load and 25°C)   |
| Mean time to replace (MTTR)       | Less than 30 minutes   |
| Nonrecoverable error rate         | Less than 1 in $10^{17}$ bits  |

### Mean Time Between Failures

The mean time between failures (MTBF) for the internal drive is specified at 250,000 hours minimum. This specification includes all power-on and operational time but excludes maintenance periods. Operational time is assumed to be 100% of the power-on time. Operational time is the time the tape is loaded.

The MTBF for the tabletop drive power supply is 50,000 hours with the unit operated at full load and 25°C.

**Note:** The MTBF rating does not represent any particular drive, but is derived from a large database of test samples. Actual rates may vary from unit to unit.

### Mean Time to Replace

The mean time to replace (MTTR) is the average time required by a qualified service technician to diagnose a defective drive and to install a replacement drive. The MTTR for LTO products is less than 0.5 hour (30 minutes).

The Quantum LTO drives are field-replaceable units. If a problem occurs with a subassembly or component in the drive, you should replace the entire unit. Return the drive to the factory in its original packaging. Contact your distributor, dealer, your computer system company or your Quantum sales representative to arrange the return.

## LTO Cartridge Specifications

### Environmental Considerations

The basic environmental tolerances for LTO Ultrium cartridges are listed in [table 23](#).

Table 23 Environmental Tolerances

| Specification                                       | Value                                       |
|---|---|
| Maximum localized temperature-permanent tape damage | Greater than 52°C                           |
| Operating temperature                               | 10°C to 40°C                                |
| Relative humidity                                   | 10% to 80% storage,<br>20% to 80% operating |
| Wet bulb temperature                                | 26° C max                                   |

If during storage and/or transportation a cartridge has been exposed to conditions outside the specified values, it must be conditioned before use in the operating environment. The conditioning shall be exposure to the operating environment for a time equal to, or greater than, the time away from the operating environment, up to a maximum of 24 hours. There shall be no deposit of moisture anywhere on or in the cartridge.

The stray magnetic field at any point on the tape shall not exceed 4000 A/m.

---

### Cartridge Memory

---

Each Ultrium cartridge has 4 Kbytes of nonvolatile memory:

- 3 Kbytes are used to store tape-directory and hardware specific information.
- 1 Kbyte is available for application and OEM use.

The cartridge memory is powered, read, and written to via a radio-frequency link.

---

### Cartridge Reliability

---

After 5,000 load/unload cycles, replace the cartridge to insure data integrity.

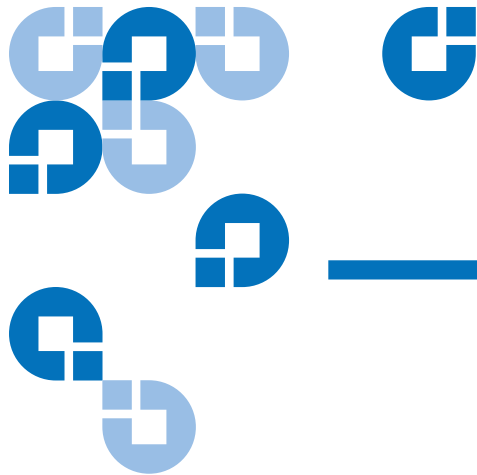

## Appendix B Data Cartridges

---

This appendix provides data cartridge information for the following A-Series tape drives:

- [Using Data Cartridges for the SDLT 600A](#)
- [Using Data Cartridges for the LTO-3A](#)

---

### Using Data Cartridges for the SDLT 600A

The Super DLTtape II data cartridge is dark blue and has a keying feature that prevent insertion into the older generation DLT tape drives, as shown in [figure 14](#).

Figure 14 Super DLTtape II  
Data Cartridge

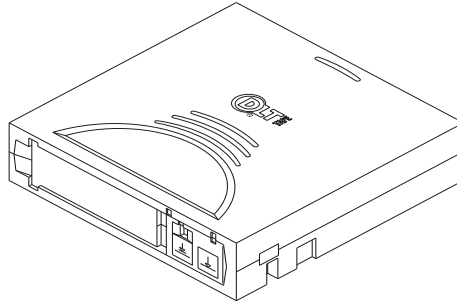

**Note:** The Super DLTtape II data cartridge has a keying feature to ensure you cannot load it into a previous generation DLT tape drives.

## Data Cartridge Handling Guidelines

By following general handling procedures, conducting careful visual inspections of data cartridges on a regular, ongoing basis, and being certain to store data cartridges within their environmental limits, you will greatly reduce any chance that you will experience problems with your data cartridges or cause damage to your Super DLTtape system. *Respect your media as much as you do your data.*

Following these general handling guidelines:

- Always keep each data cartridge in its protective plastic case when it is not in the tape drive.
- When carrying data cartridges in their cases, always orient the cases so that the grooves in the cases interlock. This prevents the cases from slipping apart and falling.
- Never stack the data cartridges in a stack of more than five.
- When placing data cartridges in archival storage, be certain you stand each data cartridge vertically.

- Do not carry data cartridges loosely in a box or any other container. Allowing data cartridges to jostle together exposes them to unnecessary physical shock.
- Always observe the proper environmental conditions for storing data cartridges. Refer to the data cartridge reference card supplied with each data cartridge. The ambient operating environment for the data cartridge is

|                   |                                  |
|-------------------|----------------------------------|
| Temperature       | 10 °C to 40 °C (50 °F to 104 °F) |
| Relative Humidity | 20% to 80% (non-condensing)      |

**Note:** If storage or transportation of a data cartridge has exposed it to conditions outside the ambient values shown above, you should condition the data cartridge to its operating environment for a 24-hour period.

- Maintain clean and smoke-free operating and storage environments.
- Never expose the data cartridge to moisture or direct sunlight.
- Do not place data cartridges on or near devices that may produce magnetic fields, such as computer monitors, motors, or video equipment. Such exposure can alter or erase data on the media.
- Avoid unnecessary opening of the data cartridge door; this may expose the media to contamination or physical damage.
- Do not touch or allow direct contact with the media or tape leader. Dust or natural skin oils can contaminate the data cartridge and impact media performance.
- A dropped data cartridge may have dislodged, loosened, or damaged internal components. If you drop a data cartridge, give it a thorough visual inspection, as described in [Data Cartridge Inspection Procedure](#).
- Never apply adhesive labels or “sticky” notes on the top, side, or bottom of your Super DLTape II data cartridge. Only use the slide-in type label provided with each data cartridge and slide it into the label slot on the data cartridge.
- Do not use graphite pencils, water-soluble felt pens, or other debris-producing writing instruments on your labels. Never erase a label – replace it.

- Be certain you place the unused data cartridge labels in the protective box so that you do not inadvertently pick them up along with the data cartridge during subsequent usage. A static electricity charge on a data cartridge may cause a label to cling to the data cartridge. A label that is accidentally inserted into the tape drive along with a data cartridge can prevent the hub reel and drive gear from meshing.
- Follow all data cartridge handling instructions that accompany your data cartridges or tape drive.

**Note:** Always remove the data cartridge from the drive prior to powering down the drive. This ensures that the file system stored on the tape is consistent and that the tape in the tape path is not damaged when the unit is powered up.

---

## Data Cartridge Inspection Procedure

Follow the Visual Mechanical Inspection (VMI) procedures described in this subsection. These steps will help you identify any potential data cartridge problems, and will prevent accidental loss of data or damage to your tape drive.

You should do an inspection if any of these conditions occur:

- As a general practice whenever you change or load a new data cartridge.
- If a data cartridge is dropped or subjected to some hard physical shock.
- If the SDLT 600A tape drive becomes inoperable after loading a data cartridge.
- If you receive a shipment of data cartridges that show any sign of shipping damage.

Follow these steps to visually inspect a Super DLTtape II data cartridge:

- 1 Remove the data cartridge from its protective plastic case.



- 2 Check for loose debris attached to the shell, and for other contamination (oily, slimy, or sticky substances) that may have built up on the surface of the shell.
- 3 Check the data cartridge for any obvious cracks or other physical damage to the shell. Rotate the data cartridge in your hands, looking for broken or missing parts.
- 4 Grasp the data cartridge to view the bottom as shown in [figure 15](#). (The media access door is on the top edge and the write protect switches are on the bottom edge.)

Figure 15 Bottom View of Super DLTtape II Data Cartridge

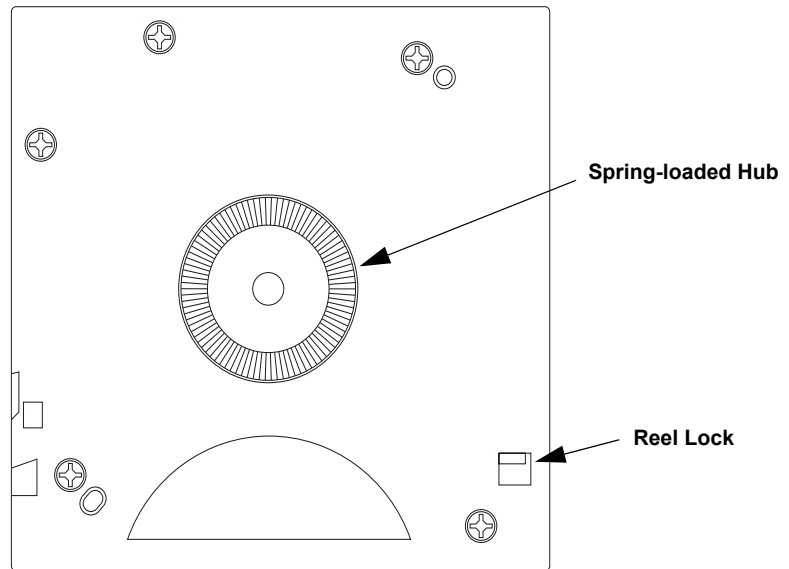

- 5 See [figure 16](#) and check the reel lock openings to ensure the small plastic tabs inside are partially visible. The reel locks are black. The reel locks can break if you drop the data cartridge. *If the reel lock tabs are not visible, do not use the data cartridge.*

Figure 16 Super DLTtape II  
Data Cartridge Reel Locks

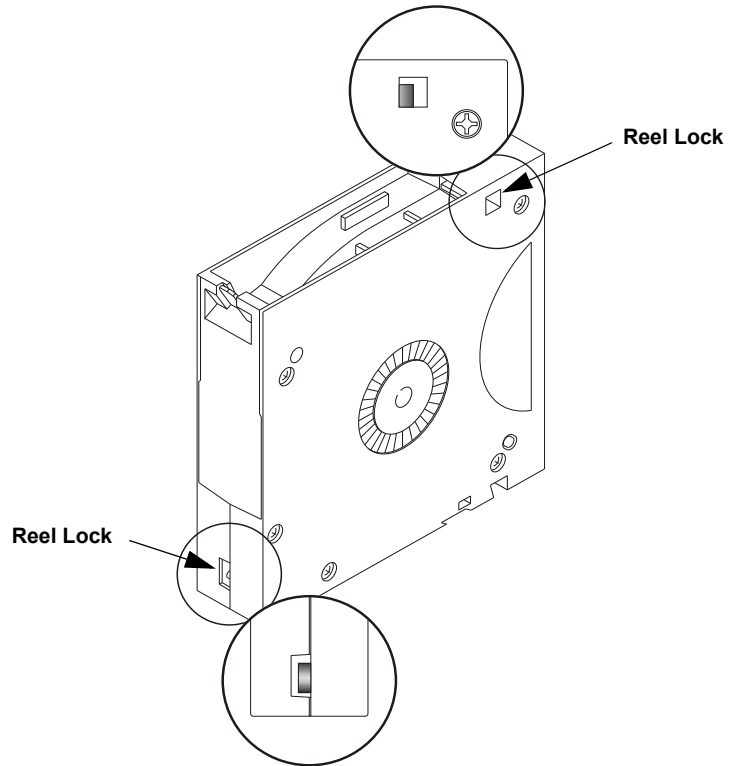

- 6 Once again, look at the end of the data cartridge, holding it as shown in [figure 17](#).

Figure 17 Opening the Super  
DLTtape II Data Cartridge Door

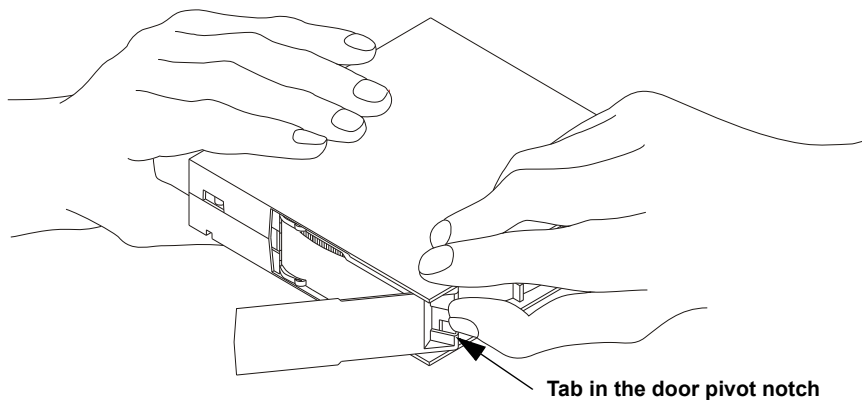

- 7 Open the data cartridge door by pressing on the tab in the door pivot notch as shown in [figure 17](#). Use care that you do not touch the tape leader.
- 8 Compare what you see inside the data cartridge door to [figure 18](#). Look for damage to the data cartridge clips, including:
  - Bent or towed-in appearance on one or both clips
  - Improper seating (clips should be fully retracted towards the left side of the opening)
  - Bending of the leader bar that supports the clips.

Figure 18 Problems to Look for Inside the Data Cartridge Door

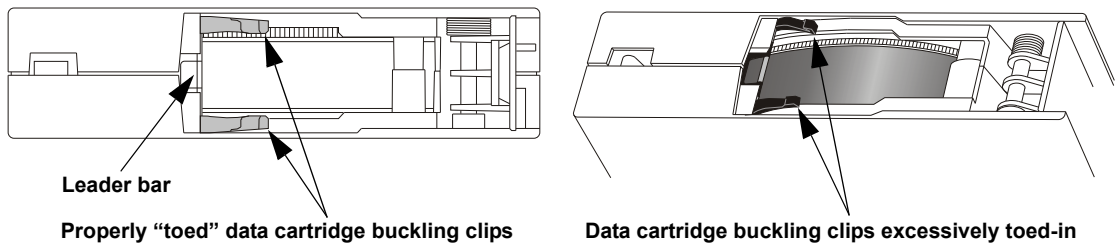

- 9 Examine the visible tape leader for excessive debris, oily or sticky residue, condensed droplets of moisture, or any other signs of contamination.
- 10 Finally, check for proper operation of the data cartridge's write-protect switch (see [figure 19](#)). This sliding switch, located on the end of the data cartridge used for the label, should snap smartly back and forth, and the orange tab should be visible when the data cartridge is set to provide write protection (you cannot write over the data already on the media).

## Data Cartridge Write-Protect Switch

Each data cartridge has a write-protect switch that you can use to prevent accidental erasure of data. Before inserting the data cartridge into the tape drive, position the write-protect switch on the front of the data cartridge ([figure 19](#)) according to the type of operations you expect to perform.

Figure 19 Write-Protect Switch on Super DLTtape II Data Cartridge

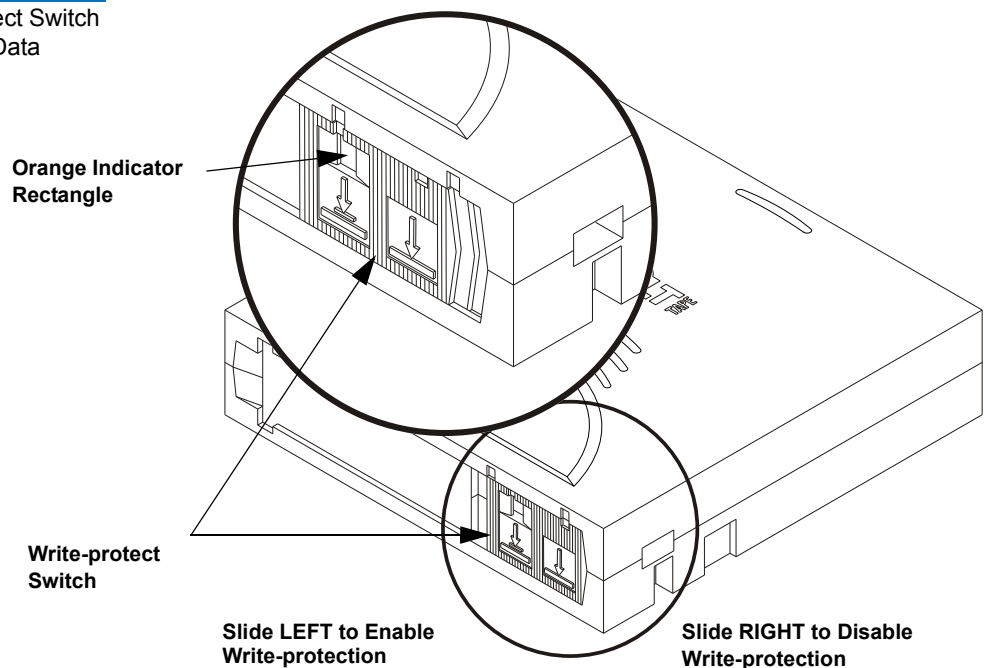

- Slide the write-protect switch to the left to *enable* write protection (you can read existing data; however, you cannot write over existing data on the media, nor append additional data to the media). When you move the write-protect switch to the left, a small orange rectangle is visible. This is your visual reminder that you cannot write data to the media.

- Slide the write-protect switch to the right to *disable* write protection (you can write over existing data on the media, and you can append additional data to the media unless the data cartridge is write-protected via firmware). When write-protection is disabled, no orange rectangle is visible.

For more details about the write-protect switch, see [table 25](#).

Table 25 Write-Protect Switch Positions

| Write-protect Switch Position  | Orange Write-protect Indicator | Result   |
|--|--------------------------------|--|
| <b>Before Loading the Data Cartridge</b>   |                                |  |
| Enabled<br>(Slide switch to left)  | Visible                        | You cannot write data to the media. You cannot overwrite existing data on the media. You cannot append additional data to the media.   |
| Disabled<br>(Slide switch to right)  | Not Visible                    | Unless the data cartridge is write-protected via firmware: <ul style="list-style-type: none"> <li>- You can write data to the media.</li> <li>- You can overwrite existing data on the media.</li> <li>- You can append additional data to the media.</li> </ul> |
| <b>After Loading the Data Cartridge and During Operation</b>   |                                |  |
| If you move the write-protect switch from its right (disabled) position to its left (enabled) position | Visible                        | If the tape drive is currently writing to a data cartridge, the write-protect feature does not take effect until <i>after</i> the current write operation completes.   |

| Write-protect Switch Position  | Orange Write-protect Indicator | Result  |
|--|--------------------------------|---|
| If you move the write-protect switch from its left (enabled) position to its right (disabled) position | Not Visible                    | The data cartridge becomes write-enabled <i>after</i> a variable amount of seconds. |

## Using Data Cartridges for the LTO-3A

### Loading a Tape Cartridge

To load an Ultrium tape cartridge into the A-Series LTO-3A tape drive, gently insert the cartridge into the slot:

- Push the cartridge further into the drive until the drive senses the cartridge and automatically completes the load operation.

Please refer to [Loading a Data Cartridge](#).

### Unloading a Tape Cartridge

To unload an Ultrium tape cartridge from the A-Series LTO-3A tape drive, either:

- Use a library or host command to unload the tape.
- Press the load/unload button on the front panel of the drive.

Please refer to [Unloading a Data Cartridge](#).

**Caution:** After you press the load/unload button, several minutes can elapse before the drive ejects the cartridge. Do not power down the tape drive or the host computer until the drive has completely ejected the cartridge.

## Write Protecting a Tape Cartridge

Ultrium tape cartridges have a sliding write-protect switch at the right-rear corner as shown in [figure 20](#).

| Sliding the write-protect switch toward the . . . | Enables data to be . . .  |
|---|---|
| center of the cartridge (the Locked position),    | read from the cartridge, but not written to it. (This is the write-protected position.) |
| corner of the cartridge (the Unlocked position),  | both read from and written to the cartridge. (This is the write-enabled position.)      |

Figure 20 Ultrium Tape Cartridge Write-Protect Switch

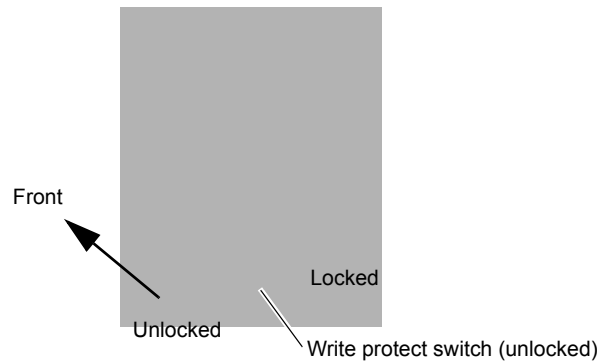

## Tape Cartridge Care and Maintenance

Observe the following precautions to protect the data on your Ultrium tape cartridges:

|                |   |
|----------------|---|
| <b>Always:</b> | <ul style="list-style-type: none"> <li>• Remove the cartridge from the drive when not in use and store it in its protective case.</li> <li>• Avoid dropping the cartridge. This can damage components inside the cartridge, possibly rendering the tape unusable. If you drop a tape cartridge, open the cartridge door and make sure that the leader pin is in the correct position.</li> <li>• Re-tension a dropped cartridge before using.</li> <li>• Keep the cartridge away from:             <ul style="list-style-type: none"> <li>• Direct sunlight and heat sources, such as radiators, heaters, or warm air ducts.</li> <li>• Sources of electromagnetic fields, such as telephones, computer monitors, dictation equipment, mechanical or printing calculators, motors, magnetic tools, and bulk erasers.</li> </ul> </li> </ul>   |
| <b>Do not:</b> | <ul style="list-style-type: none"> <li>• Expose the cartridge to dirt, dust or moisture.</li> <li>• Touch the tape media within the cartridge.</li> <li>• Bulk erase Ultrium tape cartridges. LTO tape cartridges have prewritten servo patterns that cannot be reformatted by the tape drive. A bulk erase operation would make them unusable.</li> <li>• Use tape cartridges outside the specified operating conditions: 10° C to 40° C, 20% to 80% relative humidity.</li> </ul> <p>If a tape cartridge has been exposed to conditions outside the specified range, recondition the tape before using in the operating environment by exposing it to the operating environment for a time equal to or greater than the time it was outside the operating environment, up to a maximum of 24 hours. Then re-tension the tape to stabilize the tape pack for better performance.</p> |



---

# Cleaning the Tape Mechanism

This section discusses the tape drive cleaning tape, maintenance considerations, and important compatibility issues.

**Note:** When the **Cleaning Required** LED is lit (see [Front Panel LEDs and Tape Eject](#)), use the appropriate cleaning tape (SDLT or LTO) to clean the unit. Do not clean the tape drive unless the tape drive specifically indicates cleaning is necessary.

---

## Occasional Cleaning of Tape Head

---

A-Series Tape Drives occasionally require preventive cleaning. The amount of ambient pollution and particulates in the environment, to a large degree, dictates the cleaning frequency.

Clean your tape drive only when cleaning is necessary. The alert LED located on the front bezel of the tape drive will notify you when to clean the tape drive. The location of this LED (and other front bezel LEDs) is shown in [Front Panel LEDs and Tape Eject](#).

Clean the SDLT 600A tape drive with the SDLT cleaning tape and the LTO-3A tape drive with the LTO cleaning tape.

**Caution:** Use *only* the SDLT or LTO Cleaning Tape. Other cleaning tapes are incompatible with the A-Series tape drive heads.

---

## SDLT 600A

---

The SDLT 600A tape drive uses a built-in tape cleaning algorithm in conjunction with a cleaning tape. The SDLT CleaningTape is packaged in a plastic case, and is light gray in color.

A yellow LED located on the front bezel of the SDLT 600A tape drive indicates when cleaning is needed; [Front Panel LEDs and Tape Eject](#) shows the location of this LED (and other front bezel LEDs).

---

## Life Expectancy of the Cleaning Tape

---

Each SDLT Cleaning Tape is good for 20 uses. Use one of the labels that is supplied with the tape to track the number of uses. If the cleaning LED stays lit after you clean the drive, the tape life has expired. Acquire a new cleaning tape and repeat the cleaning process.

---

## Compatibility of the Cleaning Tape

The SDLT CleaningTape is intended for use in SDLT 600A tape drives. Alternatively stated, the SDLT CleaningTape only cleans the SDLT MRC heads.

---

## Loading the Cleaning Tape Into a Tabletop Tape Drive

---

Follow these steps to load an SDLT CleaningTape into an SDLT 600A tape drive:

- 1 Insert the cleaning tape, with the Front Slide Label Slot facing outward, into the tape drive until the tape drive engages with the cleaning tape and begins to take up the cleaning media. The green **Drive Status** LED flashes and the cleaning cycle begins automatically.
- 2 When the cleaning cycle completes, the cleaning tape automatically ejects from the tape drive and the yellow alert LED turns off.

**Note:** On the last cleaning, the cleaning tape will not eject. Use the **Eject** button on the front of the tape drive to eject the expired cleaning tape and dispose of the cleaning tape.

Remove the cleaning tape, place it back into its plastic case, and mark the label after each cleaning.

---

## LTO-3A

---

Excessive tape debris or other material can accumulate on the tape heads if the drive is:

- Used with non-approved media
- Operated in a hot, dusty environment

When this happens, the drive can experience excessive errors while reading or writing, and illuminate the amber Status LED continuously during operation. This means that the drive needs to be cleaned.

The LTO cleaning cartridge has the same dimensions as the tape cartridge and contains an LTO Cartridge Memory (LTO-CM), but is loaded with cleaning media instead of recording media. Always keep the LTO cleaning cartridge in its protective case when not in use.

To clean the A-Series LTO-3A tape drive:

- 1 Load an LTO cleaning cartridge into the tape drive.

- 2 Observe that both the Status and Activity LEDs are on steady during the cleaning process.

**Note:** If the A-Series LTO-3A tape drive does not recognize the cartridge as an LTO cleaning cartridge, the drive stops the cleaning process and ejects the cartridge.

- 3 After the cleaning process completes, depending on the drive configuration, either:
  - a The drive automatically ejects the LTO cleaning cartridge, or
  - b You must press the tape load/unload button to eject the LTO cleaning cartridge.
- 4 Write the date on the cartridge label for future reference.

Each time you use the LTO cleaning cartridge, the cleaning media advances to a new, unused section. After approximately 50 cleanings, all of the media will be used up and the A-Series LTO-3 tape drive:

- Turns on the green **Activity** LED
- Fast flashes the amber **Status** LED
- Ejects the LTO cleaning cartridge

Always discard used-up LTO cleaning cartridges.

**Note:** If the amber **Status** LED comes on continuously within 24 hours after a cleaning cycle, perform the cleaning procedure again. If, after three cleaning cycles in a 72-hour period, the amber **Status** LED comes on again, contact Quantum Technical Support.

## Performing an Emergency Reset and Cartridge Eject

If the A-Series LTO-3A tape drive stops communicating with the host computer, use the following procedure to reset the drive and eject a cartridge (if necessary).

**Caution:** When you perform an emergency reset and cartridge eject, any data in the drive or host buffers will not be written to the tape and the tape record may not be correctly terminated with an end-of-data mark. If the end-of-data mark is not written to the tape, you will not be able to append any data to that tape unless you overwrite the existing data on the tape.

To perform an emergency reset, hold down the load/unload button between 5 to 15 seconds, and then release it.

| IF there is . . .     | Then the tape drive firmware . . .  |
|-----------------------|---|
| no tape in the drive, | restarts the drive and begins the Power On Self Test function.  |
| a tape in the drive,  | ignores all outstanding SCSI commands, ejects the tape, restarts the drive, and begins the Power On Self Test function. |

**Caution:** When you power down the LTO-3A drive, keep the drive in the power off condition for at least 10 seconds before re-applying power.

## Loading a Data Cartridge

Complete this subsection to load a data cartridge into the front of the tape drive; see [figure 21](#) as needed.

- 1 Insert the data cartridge into the front of the tape drive, as shown in [figure 21](#).
- 2 Push the data cartridge fully into the tape drive.

The **Drive Status** LED flashes to show that the media is loading. When the media reaches the Beginning of Tape (BOT) marker, the LED lights steadily. The data cartridge is now ready for use.

Figure 21 Loading a Super DLTtape II Data Cartridge

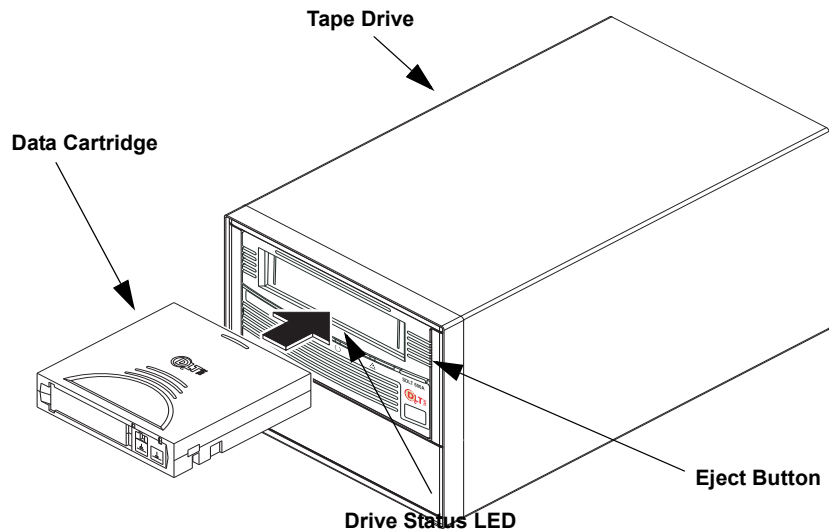

## Unloading a Data Cartridge

**Note:** A tape cartridge can be unloaded during an active FTP session only by using the built-in FTP client. Right-click within the right pane of the FTP client window to display the **Contextual** menu, then click **Eject tape**.

Follow these steps to unload a data cartridge; see [figure 21](#) as needed.

**Caution:** Remove the data cartridge from the tape drive *before* turning off host power. Failure to remove a data cartridge may result in data cartridge or tape drive damage.

Do *not* rush removal of the data cartridge. Wait until the tape drive ejects the data cartridge and the **Drive Status** LED lights steady before removing the data cartridge.

- 1 Press the **Eject** button (or issue an appropriate system software command); the tape drive completes any active writing of data to the media, then rewinds. The **Drive Status** LED flashes as the media rewinds.

When the media is finished rewinding, the tape drive ejects the data cartridge and the **Drive Status** LED lights steadily.

- 2 Remove the data cartridge from the tape drive and return the data cartridge to its plastic case to protect it from damage.

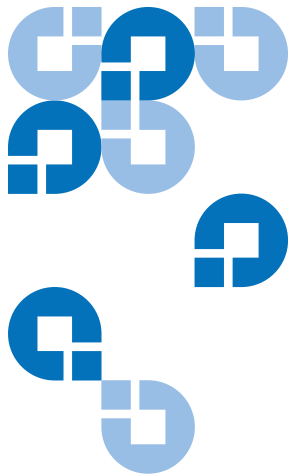

Appendix C

# Regulatory Compliance

---

This chapter describes various regulations that apply to the A-Series tape drives:

- [SDLT 600A](#)
- [LTO-3A](#)

---

# SDLT 600A

This section lists the safety regulations that the A-Series SDLT 600A Tape Drive meets or exceeds.

---

## Safety Certifications

---

The SDLT 600A tape drive meets or exceeds the following safety requirements:

- UL 60950: Information Technology Including Electrical Business Equipment (USA)
- EN60950/IEC 950: Information Technology Including Electrical Business Equipment (Europe)
  - EN60825-1 Information Technology Equipment

The SDLT 600A tape drive is also certified to bear the GS mark.

The SDLT 600A tape drive is a Class I laser product that complies with 21 CFR 1040.10 as applicable on the date of manufacture.

---

## Electromagnetic Field Specifications

---

SDLT 600A tape drives are electrical devices; as such, this equipment generates, uses, and may emit radio frequency energy. The tape drives may emit energy in other frequencies, as well, as discussed in the following subsections.

---

## Electromagnetic Emissions

---

The internal version of the SDLT 600A tape drive complies with FCC Class A limits in a standard enclosure; the tabletop version also complies with FCC Class A limits.



## Electromagnetic Interference Susceptibility

Table 26 EMI Regulations and Certifications

[Table 26](#) provides regulations and certifications held by the SDLT 600A tape drive for Electromagnetic Interference (EMI).

| Type                    | Regulation/Certification     |
|-------------------------|------------------------------|
| EEC Directive 89/336 CE | EN55022 (EU)<br>EN55024 (EU) |
| CFR 47/ICES-003         | FCC Rules Part 15B Class A   |
| ICES-003                | Canada                       |

## Immunity and ESD Limits

Table 27 Immunity and ESD Failure Level Limits

[Table 27](#) lists the immunity and ESD failure level limits to which the SDLT 600A tape drive has been tested.

| Test Name   | Test Specification | Required Performance |
|---|--------------------|----------------------|
| <b>EN55022: 1998 Radiated and Conducted Emissions</b> |                    |                      |
| Radiated Electromagnetic Emissions                    | EN55022: 1998      | Class A              |
| Conducted Electromagnetic Emissions                   |                    |                      |
| <b>Current Harmonics and Flicker Emissions Tests</b>  |                    |                      |
| AC Power Supply Harmonic Emissions                    | EN61000-3-2        | As per the standard  |
| AC Power Supply Voltage Flicker                       | EN61000-3-3        | As per the standard  |
| <b>EN55024: 1998 Immunity Tests</b>                   |                    |                      |
| Electrostatic Discharge Immunity                      | EN61000-4-2        | Criteria A           |

| Test Name                                  | Test Specification | Required Performance |
|--|--------------------|----------------------|
| Radiated Electromagnetic Immunity          | EN61000-4-3        | Criteria A           |
| Electrical Fast Transient / Burst Immunity | EN61000-4-4        | Criteria B           |
| Electrical Surge Immunity                  | EN61000-4-5        | Criteria B           |
| Conducted Electromagnetic Immunity         | EN61000-4-6        | Criteria A           |
| Power Frequency Magnetic Field Immunity    | EN61000-4-8        | Criteria A           |
| AC Voltage Dips and Interrupts Immunity    | EN61000-4-11       | Criteria B           |

## Acoustic Noise Emissions

Acoustic noise emission levels are listed in [table 28](#), both as noise power and sound pressure, for the SDLT 600A tape drive. The table provides the preliminary declared values per ISO 9296 and ISO 7779/EN27779.

Table 28 Acoustic Noise Emissions, Nominal

| Mode      | Noise Power Emission Level (LNPEc) |          | Sound Pressure Level (LPAc)* |          |
|-----------|------------------------------------|----------|------------------------------|----------|
|           | Internal                           | Tabletop | Internal                     | Tabletop |
| Idle      | Not applicable                     | 5.4 Bel  | Not applicable               | 42 dB    |
| Streaming | 5.9 Bel                            | 5.9 Bel  | 47 dB                        | 53 dB    |

\* Sound pressure level measured at front of tape drive.

## LTO-3A

The A-Series LTO-3 tape drive complies with the safety standards listed in [table 29](#) and the EMC regulations listed [table 30](#).

Table 29 Safety Compliance

| Country                  | Regulatory Organization   | Compliant to:   |
|--------------------------|---|---|
| Canada                   | Canadian Standards Association (CSA)  | CSA C22.2 No. 60950-1-03, 1st Ed.   |
| EU member nations        | Comité Européen de Normalisation Electrotechnique – the European Committee for Electrotechnical Standardization (CENELEC)   | IEC 950 / EN60950 (including amendments A1, A2, A3, A4, A11)                        |
| Germany                  | GS  | EN 60950-1, First Ed.   |
| Member nations of IECEE* | IECEE* International Electrotechnical Commission on Electrical Equipment (IECEE) for Mutual Recognition of Test Certificates for Electrical Equipment “CB Scheme” | CB Scheme per IEC 950 / EN60950 with details and exceptions for each member country |
| Russia                   | GOSSTANDART (GOST)  | CB Scheme   |
| United States            | Underwriters Laboratories (UL)  | UL-60950-1, 1st Ed.   |

\* Member nations of the IECEE include Austria, Australia, Belgium, Canada, China (PR), Czech Republic, Denmark, Finland, France, Germany, Hungary, India, Ireland, Israel, Italy, Japan, South Korea, Netherlands, Norway, Poland, Russian Federation, Singapore, Slovakia, Slovenia, South Africa, Spain, Switzerland, United Kingdom, USA, Yugoslavia.

Table 30 Electromagnetic  
Compatibility (EMC)  
Compliance

| Country           | Regulatory Organization  | Compliant to:   |
|-------------------|--|---|
| Australia         | Standards Australia Spectrum Management "C-Tick"                                       | AS/NZS 3548 (same as CISPR 22), Class B   |
| Canada            | Industry Canada Digital Apparatus - Interference-Causing Equipment Standard (ICES-003) | ICES-003: 2004 Class B: Digital Apparatus   |
| EU member nations | CE   | Emissions per CISPR 22:1997 - EN55022:1998 and Immunity per CISPR 24:1997 - EN55024:1998      |
| Japan             | Voluntary Control Council for Interface (VCCI)   | VCCI: 2006-04 Class B   |
| New Zealand       | Standards Australia Spectrum Management "C-Tick"                                       | AS/NZS 3548 (same as CISPR 22), Class B   |
| Russia            | GOSSTANDART (GOST)   | CISPR-22, Class B   |
| United States     | Federal Communications Commission (FCC)  | Title 47: Code of Federal Regulations, Part 15, Subpart B, Class B: Digital Device (47CFR15B) |

**Note:** Use the LTO-3 Half-Height Tape Drive only in equipment where the combination has been determined to be suitable by an appropriate certification organization (for example, Underwriters Laboratories Inc. or the Canadian Standards Association in North America).

Also consider the following safety points:

- Install the drive in an enclosure that limits the user's access to live parts, gives adequate system stability and provides the necessary grounding for the drive.
- Provide the correct voltages (+5 VDC and +12 VDC) based on the regulation applied – Extra Low Voltage (SELV) for UL and CSA, and Safety Extra Low Voltage for BSI and VDE (if applicable).

---

## Environmental Compliance

Quantum is committed to providing quality products in an environmentally sound manner and to comply with all applicable environmental laws, rules and regulations.

This product was designed, manufactured and made available with consideration to worldwide laws, rules and regulations applicable to the product and the electronics industry including the European Union Directives 2002/95/EC & 2002/96/EC (RoHS and WEEE).

For further information on Quantum's Environmental Compliance and Global Citizenship, please consult the following Web site at <http://qcare.quantum.com>.

---

### Perchlorate Material

---

Perchlorate Material – special handling may apply, see [www.dtsc.ca.gov/hazardouswaste/perchlorate](http://www.dtsc.ca.gov/hazardouswaste/perchlorate).

The foregoing notice is provided in accordance with California Code of Regulations Title 22, Division 4.5 Chapter 33, Best Management Practices for Perchlorate Materials. This product/part includes a lithium battery which contains a perchlorate substance.

## Disposal of Electrical and Electronic Equipment

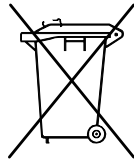

This symbol on the product or on its packaging indicates that this product should not be disposed of with your other waste. Instead, it should be handed over to a designated collection point for the recycling of electrical and electronic equipment. The separate collection and recycling of your waste equipment at the time of disposal will help to conserve natural resources and ensure that it is recycled in a manner that protects human health and the environment. For more information about where you can drop off your waste equipment for recycling, please visit our Web site at <http://qcare.quantum.com> or contact your local government authority, your household waste disposal service or the business from which you purchased the product.

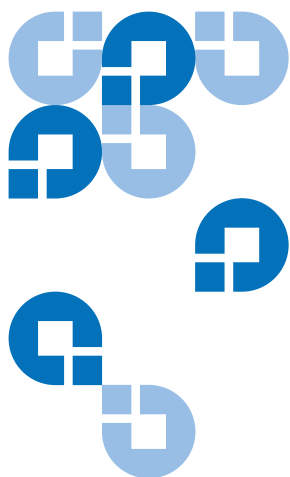

# Glossary

---

The following is an alphabetical list of specialized words and technical terms with their definitions, commonly used in the tape drive and tape media industry.

---

## A

- Access** (v.) To read, write, or update information on a storage medium, such as magnetic media. (n.) The operation of reading, writing, or updating stored information.
- Access Time** The interval between the time a request for data is made by the system and the time the data is available from the tape drive.
- Advanced PRML** Advanced Partial Response Maximum Likelihood. The advanced PRML channel technology provides high-encoding efficiency recording densities for greater capacity and performance.
- Allocation** The process of assigning particular areas of the media to particular data or instructions.
- AMP Media** Advanced Metal Powder Media. A state-of-the-art media first designed for Super DLTtape. It incorporates durable metal powder technology for high-density data storage and embedded non-magnetic information for head tracking.
- API** Application Programming Interface.

- Applet** Java applets are small Java programs that get downloaded to the client computer and then run from a web browser when a web page that uses Java is loaded.
- Archiving** The removal or copying of data from the computer system onto secondary storage media that is safely stored away.
- ASIC** Application Specific Integrated Circuit.
- ASTM** American Society for Testing and Materials.
- A/V** A/V or Audio/Video is a generic term used to describe products and services associated with audio and video.

---

**B**

- Bad Data Block** A block that cannot reliably hold data because of a media flaw or damaged format markings.
- Base Plate** An aluminum die casting that acts as the support platform for the other modules and for the tape drive enclosure. The base plate includes the precision mounting holes used to install SDLT tape drives into a server or tape library.
- Bezel** (Also known as the faceplate.) A plastic panel that extends the face of a tape drive so that it covers a computer's tape drive bay opening. The internal model of SDLT 600A has two bezels: a library bezel and an internal bezel.
- BIOS** Basic Input/Output System. A set of routines that work closely with the hardware to support the transfer of information between various elements of the system, such as memory, disks, and peripheral devices.
- Block** A sector or group of sectors. SDLT 600A supports block sizes up to 16 MB.
- BOM or BOT** Beginning of Media or Beginning of Tape. The physical beginning of the media.
- BSMI** Bureau of Standards, Metrology, and Inspection (Taiwan).
- Buckling Mechanism** The buckling mechanism engages the media leaders on cartridge load and disengages them on cartridge unload.
- Buffer** An area of RAM reserved for temporary storage of data that is waiting to be sent to a device. The data is usually on its way to or from the tape drive or some other peripheral device.



---

**C**

- C** The degree Celsius (°C) is a unit of temperature.
- Cache** Specialized RAM used as a buffer between a fast CPU or I/O channel and storage which has a relatively slow access time (for example, cartridge or diskette), to avoid slowing down the former.
- Cartridge** Tape cartridge. Super DLT tape II or SDLTtape 600A.
- Cartridge Receiver** At media insertion, the cartridge receiver assembly is responsible for guiding the media into its operating position, opening the door, unlocking the cartridge brakes, and securing the media for operation. At media ejection, the cartridge receiver assembly reverses the process and automatically ejects the cartridge a fixed distance from the front of the tape drive.
- CE** Council of Europe.
- CFR** Code of Federal Regulations (United States).
- Client** This could be a standard FTP client or the built-in FTP client embedded in the SDLT 600A firmware.
- CSA** Canadian Standards Association, also known as CSA International.
- CTM** Cartridge Tape Module. The main function of the CTM is to provide the magnetic recording media used by the tape drive to store customer information. The CTM also provides the protective cartridge, which allows the media to be removed and stored safely.
- CUP** Code Update (a firmware update).

---

**D**

- Data Compression** A process that reduces the amount of storage space required to hold a particular block of data. Data transfer speed and total media capacity are affected by the data compression achieved. In accordance with industry practice, a typical compression ratio is 2:1 of data storage. Actual compression ratios achieved depend on the redundancy of data files being written.
- dB** A Decibel is a logarithmic unit of sound intensity; 10 times the logarithm of the ratio of the sound intensity to some reference intensity.
- DC** Direct Current is the continuous flow of electricity through a conductor such as a wire from high to low potential.

- DCM** The Data Control Module provides the path and guides for all media motion inside the tape drive and to write data to and read data from the media.
- Device Driver** A low-level (usually kernel-mode) operating system component that enables a PC to communicate with peripheral devices such as printers, CD-ROMs, and tape drives. Each kind of device requires a different driver.
- DHCP** Dynamic Host Configuration Protocol – This is a protocol that lets network administrators centrally manage and automate the assignment of IP Addresses on the corporate network.
- DLT** Digital Linear Tape.
- DLT/ce** Quantum’s firmware compliance management function of DLTsage, which provides secure archival functionality to the SDLT 600A tape drive and DLTtape II cartridges.
- DLTSage** Quantum’s suite of preventative maintenance diagnostic software tools that enables users to more simply manage tape storage environments.
- DLZ** Digital Lempel-Ziv 1 Algorithm is named after Abraham Lempel and Jacob Ziv. It is a data compression technique used in all SDLT tape drives.

---

**E**

- EEC** European Economic Community.
- EEPROM** Electronically Erasable Programmable Read-Only Memory. An integrated circuit memory chip that can store programs and data in a non-volatile state. These devices store firmware in DLT and SDLT tape drives, and can be erased and reprogrammed with new data.
- EIM** The Electronic Interface Module provides the main control function for the system and the interface from the system to the host computer, library, or autoloader.
- eMAM** Enhanced Media Auxiliary Memory - The memory on a cartridge associated with the file system table of contents.
- EMC** Electromagnetic Compatibility.
- EMI** Electromagnetic Interference.
- EN** EN standards are voluntary technical standards of the European Union and European Economic Area.

- Encoding** (n.) Characters (or bytes) of information converted to magnetic patterns on the media. (v.) The process of converting to the desired pattern.
- EOD** End of Data. Location on media where the last session stopped.
- EOM or EOT** End of Media or End of Tape. Logical EOM allows space to complete a write operation; physical EOM signifies that the media is completely used.
- Erase** The removal of data from media.
- Error** A message that occurs when there is a loss of ability to interpret recorded data; usually because of magnetic issues or defects in or on the media.
- ESD** An Electrostatic Discharge is a sudden flow of electric current through a material that is normally an insulator.
- ETH** Ethernet 1Gb; GigE; Gigabit Ethernet
- EU** European Union.

---

**F**

- F** Fahrenheit is a temperature scale where a degree Fahrenheit (°F) is 5/9ths of a kelvin (or of a degree Celsius).
- FCC** Federal Communications Commission (United States).
- Fibre Channel** A high-speed serial architecture that allows either optical or electrical connections at data rates from 265 MB to 2 Gb per second. Fibre Channel is sometimes abbreviated FC.
- File system** This is the file system embedded in the SDLT 600A firmware. File system information is saved into a table of contents and also into the eMAM.
- Firmware** Permanent or semi-permanent instructions and data programmed directly into the circuitry of a programmable read-only memory or electronically erasable programmable read-only memory chips. Used for controlling the operation of the computer or tape drive. Distinct from software, which is stored in random access memory and can be altered with ease.
- FPM** The Front Panel Module (also known as the bezel) is a plastic panel that extends the face of a tape drive so that it covers a computer's tape drive bay opening.
- FTP** File Transfer Protocol - A way of transferring files over the Internet from one computer to another.
- FUP** Firmware Update.

---

|          |           |  |
|----------|-----------|--|
| <b>G</b> | <b>GB</b> | Gigabyte<br>SI – 1,000,000,000 bytes or $10^9$ . This is the International System of Units (SI) definition commonly used by telecommunications and storage manufacturers.<br>GiB – 1,073,741,824 bytes, equal to $1024^3$ , or $2^{30}$ . This is the definition often used in computer science, computer programming, and in the majority of computer operating systems documentation. This measurement can be abbreviated as GiB (gibibyte) to avoid ambiguity, as defined in IEC 60027-2.<br><b>Note:</b> For the purpose of this document, SI is used. |
|          | <b>GS</b> | German Safety.   |

---

|          |             |  |
|----------|-------------|--|
| <b>H</b> | <b>Head</b> | The tiny electromagnetic coil and metal pole used to create and read back the magnetic patterns on the media. Also known as the read/write head.   |
|          | <b>HiFN</b> | An ASIC (Application Specific Integrated Circuit) for the SDLT that handles data compression.  |
|          | <b>HIM</b>  | The Host Interface Module implements the interface between the host system and the tape drive.   |
|          | <b>HRE</b>  | Hard Read Error.   |
|          | <b>HTTP</b> | HyperText Transfer Protocol - The protocol for moving hypertext files across the Internet. Requires a HTTP client program on one end, and an HTTP server program on the other end. HTTP is the most used protocol on the Internet. |
|          | <b>HWE</b>  | Hard Write Error.  |

---

|          |                  |   |
|----------|------------------|---|
| <b>I</b> | <b>ICM</b>       | The Integrated Controller Module contains the main controller and servo microprocessor, the custom-designed SDLT ASICs, and the cache memory.   |
|          | <b>IEC</b>       | The International Electrotechnical Commission is a standards organization that prepares and publishes international standards for all electrical, electronic, and related technologies. |
|          | <b>IEEE</b>      | Institute of Electrical and Electronics Engineers   |
|          | <b>Interface</b> | A hardware or software protocol – contained in the electronics of the media controller and tape drive – that manages the exchange of data between the tape drive and computer.          |
|          | <b>IP</b>        | Internet Protocol.  |

**ISO** The International Organization for Standardization is an international non-governmental standard-setting body made up of representatives from national standards bodies.

**ISV** Independent Software Vendor.

---

**K**

**KB** A kilobyte is a unit of measure equal to 1 thousand (1024) bytes. SI – 1 000 000 bytes or  $10^6$  bytes. Computer usage – 1024 bytes.

---

**L**

**LED** Light Emitting Diode.

**LGMR** Laser Guided Magnetic Recording.

---

**M**

**μM** A Micrometer is an SI unit of length. It is defined as one millionth of a metre ( $1 \times 10^{-6}$  m), equivalent to one thousandth of a millimeter.

**MAM** Medium Auxiliary Memory (MAM) is an SDLT 600A tape drive feature that provides information on the status and prior use history of a Super DLTtape cartridge.

**MB** Megabyte  
 SI – 1 000 000 bytes or  $10^6$  bytes. This is the International System of Units (SI) definition used by telecommunications engineers and storage manufacturers.  
 1 048 576 bytes -  $1024^2$ , or  $2^{20}$ . This definition is often used in computer science and computer programming, when talking about the size of files or computer memory. The reason is that computers use the binary numeral system internally.  
**Note:** For the purpose of this document, SI is used.

**MRC Heads** Magneto Resistive Cluster Heads. A cluster of small, cost-effective Magneto Resistive (MR) media heads packed densely together.

**ms** A Millisecond is equal to one thousandth of a second.

**MTBF** Mean Time Between Failures.

**MXF** Material eXchange Format, is a file format designed to improve data and metadata exchange. The targeted objective is the interoperability between content creation mainframes, work stations and peripherals.

This wrapper file format was designed to make use of current and forthcoming data formats. It also permits conveyance of metadata following standardized schemes. This metadata is used

first to describe the structure of the file and its play out *structural metadata* but also to let the user specify its own metadata annotating the content of the file *descriptive metadata*.

This format is also designed to ensure the interchange of data in a streaming environment such as data tape storage or networked communications.

---

**N**

**Native Capacity** The capacity of a given media product in its basic recording format (without the use of data compression).

**Native Mode** Refers to the uncompressed storage capacity of a media subsystem. (See Native Capacity.)

---

**O**

**Op1a** The simplest and most common *operational pattern* containing a single *source package* which is played as is by the unique *material package*. Files produced by the Evtr from Sony are an extension of the *Op1a*.

**OpAtom** This *operational pattern* embeds a single *source package* which consists in a single source (only video or audio). However, the *material package* may allow building complex editing (*Op1a*, *Op1b*, *Op2a*, and *Op2b*) by referencing *source packages* from other *OpAtom* files.

**Operational Pattern** This term is used to designate the complexity of an MXF file. It describes the possibilities for building the *material packages*.

---

**P**

**Parity** A method of generating redundant information that can be used to detect errors in stored or transmitted data.

**Peripheral** A device added to a system as a complement to the basic central processing unit (CPU), such as a disk drive, tape drive, or printer.

**Positive Engagement Buckling Mechanism** A highly robust, solidly engineered media leader-buckling mechanism for heavy-duty-cycle automated environments.

**POST** Power-on Self-Test. When power is applied to the tape drive, it performs a POST.

**PRML** Partial Response Maximum Likelihood is a method for converting the weak analog signal from the head of a magnetic disk drive into a digital signal. Also see <Link>Advanced PRML.

**PWA** Printed Wiring Assembly - Commonly known as PCB(A) for Printed Circuit Board (Assembly).

---

**Q**

**QEZ** An Application Specific Integrated Circuit (ASIC) for the tape drive.

---

**R**

**Restore** To replace data on the hard drive with data obtained from another media device.

**RoHS** Restrictions on Hazardous Substances is an EU directive that restricts, and in some cases bans, the use of certain compounds in the manufacture of electronic equipment. RoHS mandates that new electrical and electronic equipment put on the market does not contain lead, mercury, cadmium, hexavalent chromium, poly-brominated biphenyls (PBB), or poly-brominated diphenyl ethers (PBDE).

---

**S**

**SAN** Storage Area Network.

**SDLT** Super Digital Linear Tape.

**Seek** The movement of a read/write head to a specific data track.

**Server** This is a FTP server embedded in the SDLT 600A firmware.

**Shelf Life** The length of time that media can be stored without losing its magnetic strength. For Super DLTtape II media, this period is 30 years or more.

**SI** The International System of Units.

**SITE** This command is used for site-specific commands. Compliant to FTP norm.

**SRAM** Static RAM. A memory chip that requires power to hold its content.

---

**T**

**Take-up Reel** The reel inside every tape drive onto which DLTtape or Super DLTtape media is wound. The in-the-tape drive take-up reel enables DLTtape and Super DLTtape systems to operate using a single-reel cartridge and thereby pack more media and data into every cartridge.

- Tape** Tape cartridge.
- TapeAlert™** A firmware feature that monitors and returns the results of the tape drive's on-going self-diagnosis activity.
- Tape Path** The path through which media moves from the cartridge, past the read/write head, and onto the take-up reel.
- TCM** The Tape Control Module implements the functions required to buckle and unbuckle the media and control the media motion.
- Timecode** Timecode information can be recorded within an MXF file. Given that an MXF file can have several outputs (MXF terminology: *material package*), each of them can be set to a different timecode.
- TOC** Table Of Contents - Contains file system information.
- Track** A linear or angled pattern of data written on a media surface. SDLT tape drives write information on multiple tracks simultaneously.
- Transfer Rate** The speed at which the data moves between a host (that is, tape drive) and a recorded device. Usually expressed as bytes/sec or bits/sec.
- TUR** Test Unit Ready (see also <Link>Take-up Reel).

---

**U**

- UL** Underwriters Laboratories is a testing laboratory, which develops standards for consumer products, chiefly dealing with product safety.
- Unformatted Capacity** The total number of usable bytes on the media, including the space that will be required later to record location, boundary definitions, and timing information. (See also Native Capacity.)
- URL** Uniform Resource Locator - The address of a site on the Internet.
- USB** Universal Serial Bus is a serial bus standard for connecting devices to a computer.

---

**V**

- V** A Volt is the potential difference across a conductor when a current of one ampere dissipates one watt of power.
- VCCI** Voluntary Control Council for Interference by Information Technology Equipment (Japan).



**Virtual file** A kind of edit list used only for the partial restore of .mxr files. Storing a file means creating a copy of a file from your local disk and transferring it to tape. Retrieving a file is the reverse operation. A transfer can be a store or a retrieve.

---

**W**

**W** The Watt is the SI derived unit of power.

**Web server** A computer that stores Web documents and makes them available to other computers via a web browser. A server may be dedicated, meaning its sole purpose is to be a Web server, or non-dedicated, meaning it can be used for basic computing in addition to acting as a server.

**WEEE** Waste Electronic and Electrical Equipment is an EU directive that mandates that producers of electronic goods assume the responsibility of recycling WEEE and create sustainable development programs to design more easily reusable and recyclable products.

**WORM** Write Once Read Many is a functionality, which provides secure archived records needed for government compliance.

---

**X**

**XEZ** An Application Specific Integrated Circuit (ASIC) used in SuperDLT tape drives.

**XML** eXtensible Markup Language.