



Product Manual

Product Manual

Product Manual

Product Manual

Tape Drive

SDIT 600

SDLT 600 Product Manual, 81-81184-03 A01, December 2005, Made in USA.

Quantum Corporation provides this publication “as is” without warranty of any kind, either express or implied, including but not limited to the implied warranties of merchantability or fitness for a particular purpose. Quantum Corporation may revise this publication from time to time without notice.

COPYRIGHT STATEMENT

Copyright 2005 by Quantum Corporation. All rights reserved.

Your right to copy this manual is limited by copyright law. Making copies or adaptations without prior written authorization of Quantum Corporation is prohibited by law and constitutes a punishable violation of the law.

TRADEMARK STATEMENT

Quantum, DLT, DLTtape, the Quantum logo, and the DLTtape logo are all registered trademarks of Quantum Corporation.

Quantum, DLT, DLTtape, the Quantum logo, and DLTtape logo are all registered trademarks of Quantum Corporation. SDLT and Super DLTtape are trademarks of Quantum Corporation.

Other trademarks may be mentioned herein which belong to other companies.

Contents

Preface	xi
----------------	-----------

Chapter 1	Tape Drive Product Information	1
	Overview	2
	Product Features.....	3
	Tape Drive Technology	4
	Laser Guided Magnetic Recording.....	4
	Pivoting Optical Servo.....	5
	Magneto Resistive Cluster Heads.....	5
	Advanced Partial Response Maximum Likelihood	5
	Advanced Metal Powder Media	5
	Positive Engagement Tape Leader Buckling Mechanism	5
	Modular Design.....	6
	Data Control Module.....	7
	Tape Control Module	8
	Front Panel Module	9
	Electronic Interface Module.....	9
	Super DLTtape II Data Cartridge	10
	Quantum Diagnostics Tools	10
	TapeAlert.....	11

Chapter 2	SDLT 600 Tape Drive Specifications	13
	Product Specifications	13
	Host Interface.....	13
	Physical Interface	16
	Physical Dimensions and Weights	16
	Compression	17
	Storage Capacity.....	18
	Data Integrity	18
	Maximum Data Transfer Rate	19
	Head Life and MTBF	20
	Media Durability	20
	Data Cartridge Life Expectancy	20
	Positive Engagement Tape Leader Buckling Mechanism	21
	Functional Specifications.....	21
	Performance Data.....	21
	Shock and Vibration Specifications	23
	Current and Power Requirements.....	25
	SDLT 600 Tape Drive System Recording Method.....	30
	Environmental Specifications	30
	Air Flow Requirements	30
	Temperature and Humidity	31
	Storage and Shipment.....	31
	Altitude.....	32
	Recording Media Specifications	32
	Media Structure	33
	Physical Data Cartridge	34
	Media Shipping, Operating, and Storage Specifications.....	34
	Backward-Read Compatibility Transfer Rates	36

Chapter 3	Installing Your Tape Drive	37
	Warranty Note	38
	Safety, Handling, and ESD Protection	38
	Safety Precautions	39
	Handling.....	39
	Electrostatic Discharge Protection	40
	Pre-Installation Guidelines	41
	Configuring and Installing an Internal Tape Drive with SCSI Interface.....	42
	Setting the Internal Tape Drive SCSI ID	42
	Configuring the Internal SCSI Tape Drive for TERMPWR.....	46
	Installing the Internal SCSI Tape Drive	47

Configuring and Installing an Internal Tape Drive with Fibre	
Channel Interface	55
Fibre Channel Introduction	55
Secure the Tape Drive.....	58
Connect the Power	58
Optional Loader Connector	59
Connect the Fibre Channel Cable	59
Configuring and Installing a Tabletop Tape Drive with SCSI Interface	60
Configuring the SCSI Tape Drive	60
Installing the SCSI Tabletop Tape Drive.....	62
Configuring and Installing a Tabletop Tape Drive with SCSI Interface	65
Tabletop Fibre Channel Tape Drive Model.....	65
Confirming the Installation.....	68

Chapter 4 Using Your Tape Drive 69

Power-On Self-Test	70
Performing a Trial Back-up.....	71
Updating the Firmware	72
Update the Firmware Using the SCSI Bus.....	72
Create a CUP/FUP Data Cartridge	73
Using a CUP/FUP Data Cartridge	73
Firmware (Code) Update Troubleshooting.....	75
Cleaning the Tape Mechanism	75
Occasional Cleaning of Tape Head	75
When to Use the Cleaning Tape.....	76
Life Expectancy of the Cleaning Tape.....	76
Compatibility of the Cleaning Tape	76
Loading the Cleaning Tape Into a Tabletop Tape Drive	76
Front Panel Controls and LEDs.....	77
Troubleshooting.....	80
POST Troubleshooting	80
Over Temperature Condition.....	82

Chapter 5 Regulatory Compliance 83

Safety Regulations	83
Safety Certifications	83

Electromagnetic Field Specifications	84
Electromagnetic Emissions	84
Electromagnetic Interference Susceptibility	84
Immunity and ESD Limits	85
Acoustic Noise Emissions	86
Class A Statements (Internal Tape Drive).....	86
Class B Statements (Tabletop Tape Drive).....	89
Environmental Compliance	91
Disposal of Electrical and Electronic Equipment	91

Appendix A	Super DLTtape I and Super DLTtape II Data Cartridges	92
	Recognizing Quantum Super DLTtape I and II Data Cartridges.....	93
	Data Cartridge Handling Guidelines	94
	Data Cartridge Inspection Procedure.....	96
	Data Cartridge Write-protect Switch.....	99
	Loading a Data Cartridge.....	102
	Unloading a Data Cartridge	103

Appendix B	DLTtape VS1 Data Cartridge	104
	Data Cartridge Handling Guidelines	105
	Data Cartridge Inspection Procedure.....	106
	Data Cartridge Write-Protect Switch.....	112
	Loading a Data Cartridge.....	113
	Unloading a Data Cartridge	114

Glossary		115
-----------------	--	------------

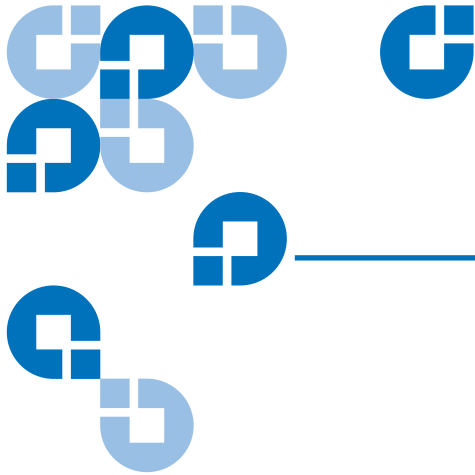

Figures

Figure 1	SDLT 600 Tape Drive Systems	3
Figure 2	SDLT 600 Tape Drive Modular Design.....	7
Figure 3	Multiple Layers Comprise Super DLTtape II Media	33
Figure 4	Super DLTtape II Data Cartridge	34
Figure 5	Detail of the Empty SCSI ID Jumper Block	43
Figure 6	10-pin SCSI ID Jumper Block on Rear of Tape Drive	45
Figure 7	TERMPWR Jumper Block on Rear of Tape Drive	47
Figure 8	Internal SCSI Tape Drive Front and Rear View	48
Figure 9	Internal Tape Drive Mounting Locations - Front, Side, and Bottom Dimensions.....	49
Figure 10	Connectors on the Rear Panel of Internal SCSI Tape Drive.....	51
Figure 11	Internal Fibre Channel Tape Drive Connectors and Jumpers.....	57
Figure 12	Connecting the Fiber Optic Cable	59
Figure 13	Rear Panel of the SCSI Tabletop Model.....	60
Figure 14	SCSI ID Selector Switch for the SCSI Tape Drive Tabletop Model	61

Figure 15	Cabling Options for the SCSI Tape Drive Tabletop Model	62
Figure 16	AC Power Cord Connector Types	64
Figure 17	Connecting the Fiber Optic Cable to a Tabletop Fibre Channel Tape Drive	66
Figure 18	AC Power Cord Connector Types	67
Figure 19	Front Panel LEDs	71
Figure 20	SDLT 600 Tape Drive Front Panel	77
Figure 21	Super DLTtape Data Cartridges Read by SDLT 600 Tape Drive.....	93
Figure 22	Bottom View of Super DLTtape II Data Cartridge	97
Figure 23	Super DLTtape II Data Cartridge Reel Locks	98
Figure 24	Opening the Super DLTtape II Data Cartridge Door	98
Figure 25	Problems to Look for Inside the Data Cartridge Door	99
Figure 26	Write-Protect Switch on Super DLTtape II Data Cartridge...	100
Figure 27	Loading a Super DLTtape II Data Cartridge	102
Figure 28	Bottom View of DLTtape VS1 Data Cartridge.....	107
Figure 29	DLTtape VS1 Data Cartridge Reel Locks	108
Figure 30	Faulty Data Cartridge Spring-loaded Reel Hub.....	109
Figure 31	Opening the DLTtape VS1 Data Cartridge Door	109
Figure 32	End View of DLTtape VS1 Data Cartridge (Tape Leader Loop in its Correct Position)	110
Figure 33	DLTtape VS1 Data Cartridges with Visible Damage.....	111
Figure 34	Write-Protect Switch on DLTtape VS1 Data Cartridge	112
Figure 35	Loading a DLTtape VS1 Data Cartridge.....	114

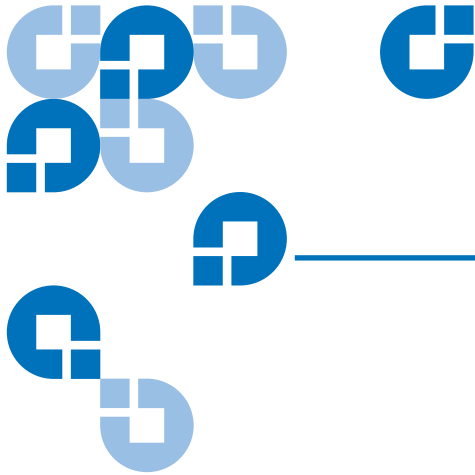

Tables

Table 1	SDLT 600 Tape Drive Interface Versions Speeds and Options	14
Table 2	SDLT 600 Tape Drive Interface	16
Table 3	SDLT 600 Tape Drive Physical Dimensions	16
Table 4	SDLT 600 Tape Drive Shipping Weight	17
Table 5	SDLT 600 Tape Drive Storage Capacity	18
Table 6	Date Transfer Error Rates	18
Table 7	Maximum Data Transfer Rates	19
Table 8	SDLTtape II Data Cartridge Media Durability	20
Table 9	Loading and Unloading the Data Cartridge (Maximum)	21
Table 10	SDLT 600 Tape Drive Performance Data	22
Table 11	Non-operating Shock Specifications (Unpackaged)	23
Table 12	Non-Operating Shock Specifications (Packaged, Drop)	23
Table 13	Non-Operating Vibration Specifications (Unpackaged)	23
Table 14	Non-Operating Vibration Specifications (Packaged)	24
Table 15	Operating Shock and Vibration Specifications	25
Table 16	Current and Power Requirements (SCSI Interface)	26
Table 17	Current and Power Requirements (Fibre Channel Interface)	28

Table 18	Temperature and Humidity Specification	31
Table 19	Tape Drive Storage and Shipment Specifications	31
Table 20	Super DLTtape II Media Specifications	32
Table 21	Super DLTtape II Media Shipping Limits	34
Table 22	Super DLTtape II Media Operating Limits	35
Table 23	Super DLTtape II Media Storage Limits	35
Table 24	SDLT 600 Tape Drive Backward-Read Compatibility (BRC) Transfer Rates	36
Table 25	SCSI ID Address Selections (Graphical Format)	44
Table 26	SCSI ID Address Selections (Tabular Format)	45
Table 27	MSE and SE Mode SCSI Connector Pin Assignments	52
Table 28	MSE LVD SCSI Connector Pin Assignments	53
Table 29	4-Pin Power Connector Pin Assignments	55
Table 30	8-Pin Loader Connector Pin Assignments	55
Table 31	LED Lighting Pattern During Power-On Self-Test (POST)	70
Table 32	Dual-Color Drive Density LED Appearance for Type of Data Cartridge Loaded	78
Table 33	How to Interpret the Front Panel LEDs and Other Controls	79
Table 34	Troubleshooting Chart	81
Table 35	EMI Regulations and Certifications	84
Table 36	Acoustic Noise Emissions, Nominal	86
Table 37	Write-Protect Switch Positions	101

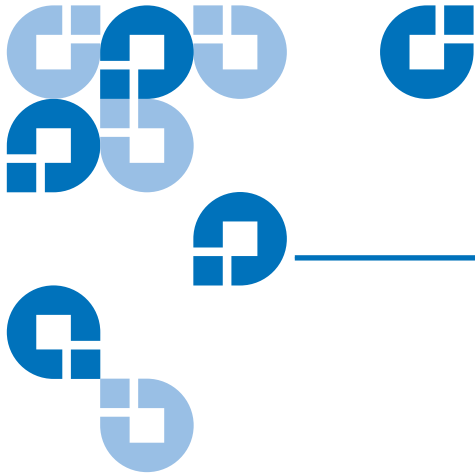

Preface

This document serves as an easy-to-use information source and product catalog to familiarize Quantum customers and systems professionals with the SDLT 600 tape drive system. The SDLT 600 tape drive is an extension of the Quantum Digital Linear Tape (DLT[®]) product family.

Audience

The primary audience for this document consists of end users installing and using the tape drive. The information in this document applies to the internal tape drive, the library tape drive, and the tabletop tape drive.

Purpose

This document provides information on the SDLT 600 tape drive including:

- Product description
- Installation instructions
- Operation instructions
- Regulatory compliance

Document Organization

This document is organized as follows:

- [Chapter 1, Tape Drive Product Information](#), provides an overview of the tape drive system, including features, tape drive technology, tape drive design, and diagnostic tools.
- [Chapter 2, SDLT 600 Tape Drive Specifications](#), provides the product, functional, environmental, and recording media specifications of the tape drive.
- [Chapter 3, Installing Your Tape Drive](#), describes warranty, safety, SCSI settings, and all the steps you need to follow to install the tape drive.
- [Chapter 4, Using Your Tape Drive](#), provides information that you need to use the tape drive, including POST, updating the firmware, cleaning the tape drive, front panel controls, and general troubleshooting guidelines.
- [Chapter 5, Regulatory Compliance](#), lists all the regulatory compliance for the tape drive.
- [Appendix A, Super DLTtape I and Super DLTtape II Data Cartridges](#), provides information on recognizing, handling, inspecting, write-protecting, loading, unloading, and “icing” cartridges.
- [Appendix B, DLTtape VS1 Data Cartridge](#), provides information about the diagnostic tools to use with SDLT 600 tape drives.

This document concludes with a glossary.

Notational Conventions

This document uses the following conventions:

Note: Notes emphasize important information related to the main topic.

Caution: Cautions indicate potential hazards to equipment and are included to prevent damage to equipment.

Warning: Warnings indicate potential hazards to personal safety and are included to prevent injury.

This document uses the following:

- **Tape Drive System** – Refers to the complete system including the cartridge.

- Tape Drive – Refers to just the tape drive and does not include the cartridge.
- Right side of the tape drive – Refers to the right side as you face the component being described.
- Left side of the tape drive – Refers to the left side as you face the component being described.
- Power cycle – Means to turn the tape drive or system on, then turn them off (or off, then on).
- Dimensions in figures – All dimensions are shown with no units specified (Inches understood unless otherwise specified).

Related Documents

The following documents are related to the SDLT 600 tape drive:

Document No.	Document Title	Document Description
81-81218-xx	SDLT 600 Product Specification	Provides hardware, performance, environment, shock and vibration, and regulatory specifications for the tape drive
81-81196-xx	SDLT 600 Design and Integration Guide	Provides information that helps you install the tape drive into a larger system
81-81283-xx	SDLT 600 Quick Start Guide	Provides “quick” instructions on how to install and run the tape drive
81-81297-xx	DLTSage and DLTIce User’s Guide	Provides information on DLTSage™ and DLTIce™, a suite of preventative maintenance diagnostic software tools that enables users to more simply manage tape storage environments.

Document No.	Document Title	Document Description
81-81220-xx	SDLT 600 User Reference Guide	Provides instructions on how to install, run the tape drive, hardware, performance, environment, shock and vibration, and regulatory specifications for the tape drive
81-81305-xx	SDLT 600 Quick Start Guide	Provides brief instructions on how to install the tape drive
81-81202-xx	SDLT 600 Fibre Channel Interface Guide	Provides Fibre Channel command information specific to the tape drive.
81-81200-xx	SDLT 600 SCSI Interface Guide	Provides SCSI command information specific to the tape drive.
6464162-xx	SDLT DLTtape Interactive Library Interface Specification	Provides information specific to the library tape drive.
81-81252-xx	Bezel Replacement Guide	Provides instructions on how to replace the bezel on the tape drive

Current SCSI standards documents available from www.t10.org

- SCSI Architecture Model (SAM-3)
- SCSI Primary Commands (SPC-3)
- SCSI Parallel Interface (SPI-5)
- SCSI Stream Commands (SSC-3)
- Fibre Channel Protocol (FCP-2)
- Fibre Channel Framing and Signaling (FC-FS-2)
- Fibre Channel Arbitrated Loop (FC-AL-2)
- Fibre Channel General Services (FC-GS-5)

See the appropriate documentation for information on the tape drive and cartridges.

SCSI Standards

Copies of the approved version of the SCSI standards may be obtained from:

Global Engineering Documents
15 Inverness Way, East
Englewood, CO 80112
(800) 854-7179 or (303) 397-2740

Contacts

Quantum company contacts are listed below.

Quantum Corporate Headquarters

To order documentation on this or other Quantum products, contact:

Quantum Corporation
141 Innovation Drive
Irvine, CA 92617
(949) 856-7800
(800) 284-5101

Technical Publications

To comment on existing documentation send e-mail to:

doc-comments@quantum.com

Quantum Home Page

Visit the Quantum home page at:

<http://www.quantum.com>

Customer Support

The Quantum Customer Support Department provides a 24-hour help desk that can be reached at:

North/South America: (949) 725-2100 or (800) 284-5101

Asia/Pacific Rim: (International Code) + 61 7 3839 0988

Europe/Middle East/Africa: (International Code) + 44 (0) 1256 848748

Send faxes for the Customer Support Department to:

North/South America: (949) 725-2176

Asia/Pacific Rim: (International Code) + 61 7 3839 0955

Europe/Middle East/Africa: (International Code) + 44 (0) 1256 848777

Send e-mail for the Customer Support Department to:

North/South America: http://www.quantum.com/am/service_support/Index.aspx

Asia/Pacific Rim: apachelp@quantum.com

Europe/Middle East/Africa: eurohelp@quantum.com

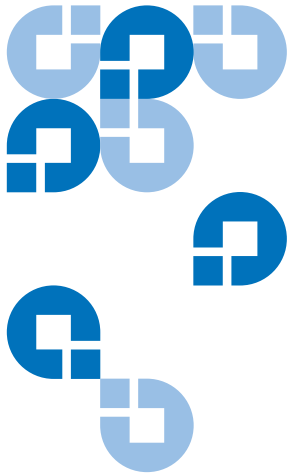

Chapter 1

Tape Drive

Product Information

This chapter describes the features of the Quantum SDLT 600 tape drive system. This chapter covers the following topics:

- [Overview](#) describes basic features of the system.
- [Product Features](#) lists key features of the SDLT 600 tape drives.
- [Tape Drive Technology](#) includes photographs of the tape drive, and introduces important basic features.
- [Modular Design](#) introduces tape drive components such as the tape heads, media, data cartridge, and host interface.
- [Quantum Diagnostics Tools](#) describes tools and utilities that provide the ability to run diagnostics and test for drive functionality.
- [TapeAlert](#) describes a built-in tape device status monitoring and messaging utility.
- [Medium Auxiliary Memory](#) introduces an SDLT 600 tape drive feature that provides key input for the DLTSage suite of maintenance diagnostics software.

Overview

The Quantum SDLT 600 tape drive system is a highly scalable tape drive designed for multiple product generations. It is a follow-on to the DLT product family. The SDLT 600 tape drive system comprises both the tape drive and the data cartridge. The system is available in three models: a tabletop (or external) unit, an internal unit for server installation, and a library model for installing in tape automation systems. The model SDLT 600 tape drive system provides 300 Gigabyte (GB) of storage capacity with a transfer speed of 36 Megabyte per second (MB/sec) native; 600 GB of storage capacity with a transfer speed of 72 MB/sec compressed.

[Figure 1](#) shows pictures of the internal and tabletop models. The library model (not shown) is identical to the internal, but with a different front bezel.

For detailed engineering specifications, see [chapter 2, SDLT 600 Tape Drive Specifications](#)

Figure 1 SDLT 600 Tape Drive Systems



Product Features

The SDLT 600 tape drive system offers the following product features:

- A streaming tape drive that uses half-inch wide Super Digital Linear Tape (Super DLTtape II) media.
- A standard 5.25-inch full-height form factor to simplify integration into system and tape library solutions.

- Backward read compatibility for SDLT 220 and SDLT 320 tape drive formats with the Super DLTtape I data cartridge type; and the DLT VS160 tape drive format with DLTtape[®] VS1 data cartridge type.
- DLTSage iTalk (and Pocket DLTSage iTalk)—Infrared (wireless) interface that provides a remote testing base allowing customers and integrators to access system diagnostic information from the front of the SDLT 600 tape drive system.
- The SDLT 600 tape drive is available in either Ultra 160 or Fibre Channel interface versions.
- For more information on the SDLT 600 tape drive features and other product information, you can access the Web site at:

<http://www.dlftape.com/Home.htm>

This web page provides information that is constantly updated as needed. Refer to this Web site often to obtain the most current information.

Tape Drive Technology

The SDLT 600 tape drive incorporates various new state-of-the-art technologies that contribute to the SDLT architecture. Some of these ideas are trademarked, others are patented. The following subsections introduce the important technologies that together, comprise the SDLT 600 tape drive system.

Laser Guided Magnetic Recording

The SDLT 600 tape drive systems (shown in [figure 1](#)) are based on Quantum's Laser Guided Magnetic Recording (LGMR) technology. LGMR provides a unique combination of the best optical and magnetic technologies, which results in dramatically higher capacities by substantially increasing the number of recording tracks on the data-bearing surface of the media. By recording data magnetically on the data-bearing side of the media and using servo movement optically on the backside, LGMR optimizes highly proven technologies to deliver the most efficient, reliable, and scalable data backup solution to the mid-range market.

Pivoting Optical Servo

Pivoting Optical Servo (POS) is a Quantum-invented, optically-encoded servo system, that combines high-density magnetic read/write data recording with laser servo guiding. The POS provides high-duty-cycle applications, which decreases cost and increases user convenience. The POS enables the head to track dynamic variations in tape motion which allows Quantum to provide a track count with an order of magnitude increase over previous products.

Magneto Resistive Cluster Heads

Magneto Resistive Cluster (MRC) heads are a densely packed array of small, cost-effective Magneto Resistive (MR) tape heads precisely positioned using advanced thin-film processing technology. SDLT MRC heads provide high wafer usage efficiency resulting in low head costs, are less susceptible to variations in tape speed, yield higher track density and capacity, and provide a multi-channel architecture for increased transfer rate and performance.

Advanced Partial Response Maximum Likelihood

Improving on Partial Response Maximum Likelihood (PRML) technology traditionally used in disk drives and communication systems, Quantum's advanced PRML channel technology, co-developed with Lucent Technologies, brings new levels of performance and capacity to high-performance linear tape products. This provides high-encoding efficiency recording densities for greater capacity and performance that enables SDLT to increase transfer rates and capacity substantially.

Advanced Metal Powder Media

Advanced Metal Powder (AMP) media is a state-of-the-art media using durable metal powder technology for recording very high densities of data. The back side of the AMP media receives a specially formulated coating to accept the optical servo tracks. Because the servo information is on the back side of the media, the entire data-bearing side of the media is available for recording data and eliminates the need for pre-formatting. In addition, AMP media meets the needs of multiple generations of the SDLT technology.

Positive Engagement Tape Leader Buckling Mechanism

The positive engagement tape leader buckling mechanism is a highly robust mechanism that increases data cartridge life and supports the

extensive duty-cycle environments found in high-end and automation environments.

This mechanism engages the tape leader upon data cartridge load and disengages it upon data cartridge unload. It uses a solid metal pin attached to the drive leader to link with molded clips permanently attached to the tape leader inside the data cartridge. The Positive Leader Link design makes the buckling of Super DLTtape media a totally reliable mechanical process.

Modular Design

The SDLT 600 tape drive is designed as a total system. The system includes a complex interaction of a number of important components including such items as the tape path, tape heads, media, data cartridge, and host interface.

As shown in [figure 2](#), the SDLT 600 tape drive consists of five distinct modules:

- Data Control Module (DCM)
- Tape Control Module (TCM)
- Front Panel Module (FPM)
- Electronic Interface Module (EIM)
- Super DLTtape II Data Cartridge (Data Cartridge).

The modular concept makes the SDLT 600 tape drive system easy to manufacture and configure. Each module is optimized to perform a specific set of functions and designed to interface with the other modules in a well defined and flexible manner.

The following subsections provide a brief overview of each module.

Figure 2 SDLT 600 Tape Drive
Modular Design

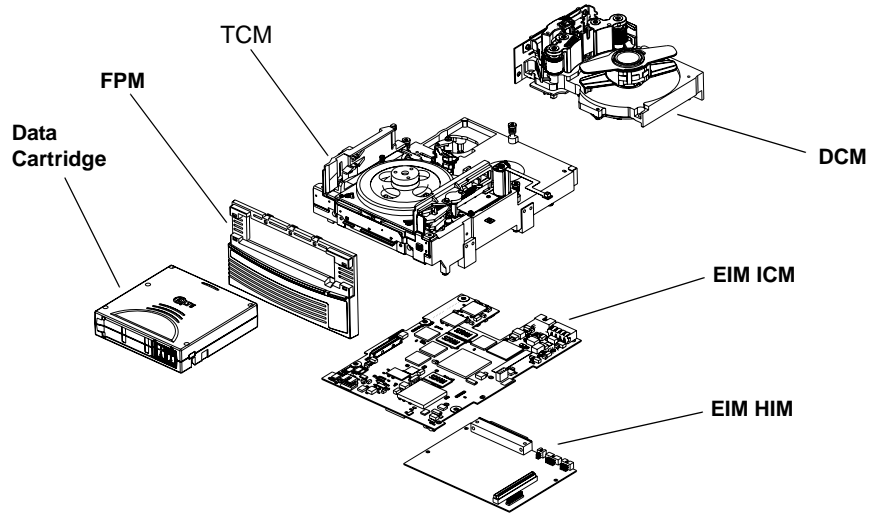

Note: Despite the deliberate modularity of each module, with the exception of the FPM, individual users should not **swap** modules. The FPM is the only module that is field replaceable. Customer adjustments to the TCM, DCM, or EIM will void the tape drive's warranty.

Data Control Module

The Data Control Module (DCM) contains several of the functions and features of LGMR technology, which is at the heart of the SDLT technology. Of the five technologies that constitute the LGMR technology, two are in the DCM. These are the POS and the MRC heads.

The main functions of the DCM are to provide the path and guides for all tape motion inside the tape drive and to write data to and read data from the tape. In addition to the POS and MRC heads described in [Pivoting Optical Servo](#) and [Magneto Resistive Cluster Heads](#), the DCM contains a number of components that interact to perform these functions. These components include:

- Advanced head guide assembly
- Take-up reel
- Drive motor
- Optical servo system

- Tape heads.

In addition to its mechanical components, the DCM also contains printed circuit boards that control the functions of the DCM and the tape heads.

Tape Control Module

The Tape Control Module (TCM) implements the functions required to buckle and unbuckle the tape and control the tape motion. The TCM consists of a variety of components:

- TCM Printed Circuit Board Assembly (PCBA)
- Base Plate
- Data Cartridge Receiver
- Positive Engagement Tape Leader Buckling Mechanism
- Tape supply motor assembly
- Floor plate assembly.

TCM PCBA

The TCM has its own PCBA that controls the functions of the TCM and interfaces with the main controller board in the EIM. By designing the TCM as a distinct module, it allows manufacturing and testing the TCM as a stand-alone module, simplifying the design, manufacturing, and troubleshooting processes.

Base Plate

The SDLT 600 tape drive base plate is an aluminum die casting with precisely machined surfaces. The casting acts as the support platform for the other modules and for the tape drive enclosure. The base plate also includes the precision mounting holes used to install SDLT 600 tape drives into a server or tape library. The SDLT 600 tape drive base plate, and therefore the entire SDLT 600 tape drive, conforms to the 5.25 inch, full-height form factor.

Data Cartridge Receiver

On tape insertion, the data cartridge receiver assembly guides the tape into its operating position, opens the data cartridge door, unlocks the data cartridge brakes, engages the data cartridge drive motor, and secures the tape for operation. On tape ejection, the data cartridge receiver assembly reverses the process and automatically ejects the tape a fixed distance from the front of the tape drive.

Positive Engagement Tape Leader Buckling Mechanism

The buckling mechanism is responsible for engaging the tape leader upon data cartridge load and disengaging it on data cartridge unload. See [Positive Engagement Tape Leader Buckling Mechanism](#) for more information.

Front Panel Module

The Front Panel Module (FPM) of the system (sometimes referred to as the bezel) performs a number of functions:

- Protecting the front of the TCM from physical damage
- Channeling airflow through the system
- Aligning the data cartridge when it is inserted into the system
- Providing system status and information through LEDs
- Enabling data cartridge ejection
- Delivering the overall cosmetic look of the system.

The FPM is a single module with lenses for the system's LEDs and a button to activate the drive eject switch. The SDLT 600 tape drive front panel contains no electronics.

Electronic Interface Module

The Electronic Interface Module (EIM) is the electronic heart of the SDLT 600 tape drive system. It provides the main control function for the system and the interface from the system to the host computer, library, or autoloader. The EIM provides the Advanced PRML feature of Quantum's SDLT technology. See [Advanced Partial Response Maximum Likelihood](#) on page 5 for a brief description of PRML.

The EIM consists of two major boards: the Integrated Controller Module (ICM), and a separate Host Interface Module (HIM). The ICM contains the main controller and servo microprocessor, the custom-designed SDLT ASICs, and the cache memory while the HIM implements the interface between the host system and the tape drive. This allows easy configuration of the tape drive to match different host interfaces by simply substituting the appropriate HIM card.

As with the other major modules of the SDLT technology, the EIM is manufactured and tested as a distinct module.

Super DLTtape II Data Cartridge

As with all tape technologies, the Super DLTtape II data cartridge is a key part of the overall system. The main function of the data cartridge is to provide the magnetic recording media used by the system to store customer information. The data cartridge also provides the protective casing that allows safe media movement and storage.

From the outside, the Super DLTtape II data cartridge looks very similar to the Super DLTtape I and DLTtape VS1 data cartridges. The basic geometry, write protection switch, and label space are the same. This simplifies the integration of the SDLT 600 tape drive into existing operating environments and into automated tape libraries. The Super DLTtape II data cartridge is easy to recognize; it has a different color than the Super DLTtape I and DLTtape VS1 data cartridges, and contains a distinctive pattern molded into the shell. The DLTtape logo and the product name are also molded into the shell, which ensure you have a genuine Quantum Super DLTtape II data cartridge.

Quantum Diagnostics Tools

Quantum frequently provides new and updated tools to use with its tape drives. These tools include such items as upgrades for product software and firmware, and diagnostic software that may be newly developed. All these tools are available on the Quantum Web site.

<p>Note: These tools are only available to registered Quantum customers.</p>

Refer to the following procedure to access these tools.

- 1 Go to the Quantum Web site: <http://www.quantum.com>.
- 2 Click **SERVICE AND SUPPORT** in the upper menu bar. This opens the Service and Support window.
- 3 Explore the various pages that comprise Service and Support until you find what you need.

New tools and utilities get added frequently, so check back often.

TapeAlert

SDLT 600 tape drives are delivered with TapeAlert™ features built in. The internal SDLT firmware constantly monitors the device's hardware and media, checking for errors and potential difficulties. It flags any problems identified on the SCSI log page, where 64 bytes are reserved for use by TapeAlert.

After a backup, the TapeAlert-compatible backup application automatically reads the device's TapeAlert SCSI log page to check for any problems. If an error is flagged, your backup software displays a clear warning message on your screen, and adds the TapeAlert messages to its logs. These messages are standard across all applications that support TapeAlert, and give clear explanation of the problem and suggested resolution. For example, if you were attempting to back up onto an expired tape, you would see the following message:

Warning: The data cartridge has reached the end of its useful life:
Copy any data you need to another tape. Discard the old tape.

Medium Auxiliary Memory

Medium Auxiliary Memory (MAM) is a feature in the SDLT 600 tape drive that produces various attributes about the data cartridge and records them in a log file on the media itself. These attributes provide the underlying information for the DLTSage suite of predictive and preventive maintenance diagnostics software.

For more information about MAM, see the *SDLT 600 SCSI Interface Guide (81-81200-xx)* or the *SDLT 600 Fibre Channel Interface Guide (81-81202-xx)*. For more information about DLTSage, see the *DLTSage Implementation Guide (81-81201-xx)*.

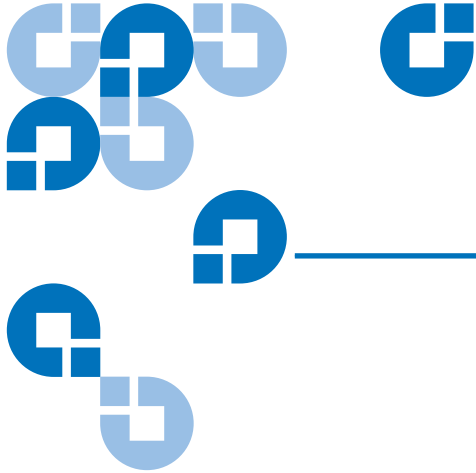

Chapter 2

SDLT 600 Tape Drive Specifications

This chapter describes various specifications that apply to the Quantum SDLT 600 tape drive system:

- [Product Specifications](#) provides tape drive specifications
- [Functional Specifications](#) provides functional specifications for the tape drive
- [Environmental Specifications](#) provides environmental specifications for operating the tape drive
- [Recording Media Specifications](#) provides media specifications for Super DLTtape II data cartridges.

Product Specifications

The following subsections contain full product specifications for the Quantum SDLT 600 tape drive.

Host Interface

The Ultra 160 SCSI and Fibre Channel interfaces are available in both the internal and tabletop models.

Table 1 SDLT 600 Tape Drive Interface Versions Speeds and Options

Interface Versions	Speeds	Protocol Options
Fibre Channel	<ul style="list-style-type: none"> • 100 MB/second • 200 MB/second 	<ul style="list-style-type: none"> • Class3 • Connect to N port, NL port, FL port • FC-MI • FC-AL-2 • FCP-2 • FC-FS • SCSI-3 (SAM-2, SPC-2, or SSC)
Ultra 160	<ul style="list-style-type: none"> • 160 MB/second maximum burst speed ** 	<ul style="list-style-type: none"> • Multi-mode Single-Ended (MSE) provides one of two differential senses: <ul style="list-style-type: none"> - Low Voltage Differential (LVD) running up to 160 MB/second, or - Single Ended (SE) running up to 40 MB/second • Ultra 160 2/FAST-20/ Asynchronous • SCSI-3 (SAM-2, SPC-2, and SSC) • Supports up to 15 hosts

** The SCSI bus itself limits this speed, not the design of SDLT 600 tape drive or Super DLTape II media.

Ultra 160 SCSI Interface

The Ultra 160 SCSI interface provides a low-voltage differential (LVD) mode running up to 160 MB/second and a single-ended (SE) mode running up to 40 MB/second.

Note: The host computer's SCSI controller card may limit these speeds. To achieve the best performance, make sure the SCSI controller card can operate at 160 MB/second.

The tape drive automatically senses the SCSI bus mode and switches between LVD and SE accordingly. Although the tape drive defaults to LVD, it switches to SE if the SCSI bus operates in SE mode. For example, if the SCSI controller card is SE (or multimode set to SE), the tape drive automatically switches to SE mode. Also, if any device on the SCSI bus is SE, the entire bus switches to SE, including the tape drive.

In SE mode, the SCSI bus can support up to 7 devices using cable lengths up to 3 meters. In LVD mode, the SCSI bus can support up to 15 devices using cable lengths up to 25 meters.

For more information about the SCSI interface, see the *SDLT 600 SCSI Interface Guide (81-81200-xx)*.

Fibre Channel Interface

The Fibre Channel interface runs at speeds up to either 1 Gb/second or 2 Gb/second, depending on the configuration you choose during installation.

Fibre Channel can support up to 126 devices in a loop configuration. Longwave transceivers (with fiber optic cable) support distances up to 10 kilometers; shortwave transceivers (with fiber optic cable) support distances up to 500 meters.

For more information about the Fibre Channel interface, see the *SDLT 600 Fibre Channel Interface Guide (81-81202-xx)*.

Physical Interface

The SDLT 600 tape drive has the interfaces shown in [table 2](#) available from the back panel (per type, per port).

Table 2 SDLT 600 Tape Drive Interface

Interface Versions	Physical Characteristics
Fibre Channel	Topology-constrained (force point-to-point)
	1 Gbit or 2 Gbit interface (selectable at time of installation)
	850 nanometer LC connector transceiver (optional)
Parallel SCSI	MSE, LVD
	Ultra 160
	SCSI ID (user selectable at time of installation)
	TERMPWR connector style: 4-pin
	Connector style: 68-pin high density SCSI

Physical Dimensions and Weights

[Table 3](#) provides physical dimensions for the SDLT 600 tape drive system.

Table 3 SDLT 600 Tape Drive Physical Dimensions

	Internal Version	Library Version	Tabletop Version
Height	82.55 mm (3.25 in.) without front bezel	82.55 mm (3.25 in.) without front bezel	164.46 mm (6.48 in.)
	85.73 mm (3.38 in.) with front bezel	85.73 mm (3.38 in.) with front bezel	
Width	146.05 mm (5.75 in.) behind front bezel	146.05 mm (5.75 in.) behind front bezel	174.75 mm (6.88 in.)
	148.59 mm (5.85 in.) with front bezel	148.59 mm (5.85 in.) with front bezel	

	Internal Version	Library Version	Tabletop Version
Depth	203.20 mm (8.00 in.) from back of front bezel 215.40 mm (8.48 in.) including front bezel	203.20 mm (8.00 in.) from back of front bezel 212.22 mm (8.36 in.) including front bezel	320.04 mm (12.60 in.)
Mounting hole pattern for the bottom and sides of the system is industry standard.			

[Table 4](#) shows the weights of the SDLT 600 tape drive.

Table 4 SDLT 600 Tape Drive
Shipping Weight

	Internal Version	Tabletop Version
Weight*	2.38 kg (5 lbs. 4 oz)	6.27 kg (13 lbs. 13 oz)
Shipping Weight*	3.77 kg (8 lbs. 5 oz)	9.90 kg (21 lbs. 13 oz)
* Weights depend on configuration. The packaging used may change the shipping weight.		

Compression

The tape drive contains on-board hardware to compress and decompress data using a DLZ algorithm. The default setting for data compression is on.

Storage Capacity

[Table 5](#) provides native and compressed capacity ranges for the Super DLTtape II data cartridge:

Table 5 SDLT 600 Tape Drive Storage Capacity

Mode	Capacity
Native Storage Capacity	300 GB
Compressed Storage Capacity	600 GB (2:1 compression ratio)

In accordance with industry practice, a typical compression ratio of 2:1 is quoted. The redundancy and type of data files being written determine the actual compression ratios achieved.

Data Integrity

SDLT 600 tape drive data transfer errors are extremely rare; [table 5](#) shows data integrity for the overall SDLT 600 tape drive system.

Table 6 Date Transfer Error Rates

Error Type	Frequency
Detected, Recoverable (ECC) READ	< 1 error in 10^6 bytes read
Detected, Unrecoverable READ	< 1 error in 10^{17} bits read
Undetected READ	< 1 error in 10^{27} bits read
Rewrite of Data	< 1 per 10^6 bytes written

Maximum Data Transfer Rate

[Table 7](#) shows the maximum sustained (and burst) data transfer rates for the SDLT 600 tape drive.

Table 7 Maximum Data Transfer Rates

Configuration	Native	Compressed*	Burst Max**
SCSI Ultra 160 (MSE LVD mode)	36 MB/sec	72 MB/sec	160 MB/sec
SCSI Ultra 160 (SE mode)	36 MB/sec	40 MB/sec	40 MB/sec
Fibre Channel (1 Gbps)	36 MB/sec	72 MB/sec	100 MB/sec
Fibre Channel (2 Gbps)	36 MB/sec	72 MB/sec	200 MB/sec

* The compression rates shown assume an industry standard 2:1 compression ratio. Actual compression ratios achieved depend on the redundancy of data files being recorded. For non-compressible (expanding) data, this results in a reduction in capacity and transfer rate for the data. Fully random data is the worst case for compressibility.

** The SCSI bus limits burst speeds, not the design of SDLT 600 tape drive or Super DLTtape II media.

Note: Cable lengths and cable type may limit attainable transfer rate; for details, see the *SDLT 600 Design and Integration Guide (81-81196-xx)*.

Head Life and MTBF

The projected mean time between failures (MTBF) for the overall SDLT 600 tape drive system is 250,000 hours, not including the heads. Head life is a minimum of 30,000 tape motion hours and an average of 50,000 media motion hours.

Note: The manufacturer does not warrant that predicted MTBF is representative of any particular unit installed for customer use. Actual figures vary from unit to unit.

Media Durability

[Table 8](#) shows the number of media passes and full media uses to expect from a Super DLTtape II data cartridge.

Table 8 SDLTape II Data Cartridge Media Durability

	Media Durability
Media passes*	1,000,000
Full media uses**	250

* A media pass occurs with any movement (in either direction) of the surface of the media over the tape head.

** A full media use is an operation that reads or writes (with verify off) the full capacity of the data cartridge.

Data Cartridge Life Expectancy

[Table 9](#) shows the number of load and unload cycles you can expect before the data cartridges need to be replaced.

Table 9 Loading and Unloading the Data Cartridge (Maximum)

	Super DLTtape II Data Cartridge
Data cartridge load/unload cycles*	5,000
Media insertions**	20,000

* A load/unload cycle is when a data cartridge is inserted into the receiver, loaded to BOT, calibrated, and then unloaded.

** An insertion is when a data cartridge is inserted into the receiver and then unloaded.

Positive Engagement Tape Leader Buckling Mechanism

This buckling mechanism engages the tape leaders upon data cartridge load and disengages them upon data cartridge unload.

Component level tests of buckle arm components have shown at least 250,000 cycles on an SDLT 600 tape drive without failure, breakage, or binding; this includes the take-up leader, the supply leader, and the media itself.

Functional Specifications

The following subsections contain functional specifications for the Quantum SDLT 600 tape drive.

Performance Data

[Table 10](#) provides performance data for the SDLT 600 tape drive system. For a comparison of SDLT 600 tape drive storage capacities, see [Storage Capacity](#) on page 18.

Table 10 SDLT 600 Tape Drive Performance Data

Feature	SDLT 600 Tape Drive
Drive Read/Write Transfer Rate*	36 MB/second, native 72 MB/second, compressed
Tracks	40 logical tracks 640 physical tracks
Track Density	1502 tracks per inch (tpi)
Linear Bit Density	233 Kbits per inch (Kbpi)
Read/Write Tape Speed	108 inches per second (ips)
Rewind Tape Speed	160 ips
Linear Search Tape Speed	160 ips
Average Rewind Time**	77 seconds
Maximum Rewind Time**	156 seconds
Average Access Time** (from BOT)	79 seconds
Maximum Access Time** (from BOT)	190 seconds
Load to BOT**	18 seconds (typical) 63 seconds (unformatted tape)
Unload from BOT**	19 seconds
Nominal Tape Tension	Stationary: 3.0 ± 0.5 oz Operating Speed: 3.5 ± 0.5 oz
<p>* Depending on data type and SCSI bus limitations/system configuration.</p> <p>** Note that data is typical; times may be longer if error recovery time is necessary, or if the command times out for any reason. For information on SCSI command timeout values, see the <i>SDLT 600 Design and Integration Guide, 81-81196-xx</i>.</p>	

Shock and Vibration Specifications

The following tables provide non-operating and operating shock and vibration specifications for the SDLT 600 tape drive system.

Table 11 Non-operating Shock Specifications (Unpackaged)

Shock (Unpackaged)		
Pulse Shape	Square wave	½ sine pulse
Peak Acceleration	40 G	140 G
Duration	10 ms (180 inches/second)	2 ms
Application	X,Y,Z axes, twice in each axis (once in each direction)	

Table 12 Non-Operating Shock Specifications (Packaged, Drop)

Shock (Packaged, Drop)	Height of Drop	Number of Drops	Package Weight
Drop	42 inches	16 drops total	0 lbs. < package weight ≤ 20 lbs.
	36 inches	16 drops total	20 lbs. < package weight ≤ 50 lbs.

Table 13 Non-Operating Vibration Specifications (Unpackaged)

Vibration (Unpackaged)		
Type	Sine	Sweep
Frequency Range	5 to 500 to 5 Hz	Upward and downward sweep
Acceleration Level	0.02" DA 1.0 G	Between 5 and 31 Hz (crossover) Between 31 and 500 Hz (crossover)

Vibration (Unpackaged)

Application	X,Y,Z axes	Sweep rate = ½ octave/minute
Type	Random	
Frequency Range	10 to 500 Hz	
Acceleration Level	2.0 G	
PSD Envelope	0.008 G ² /Hz	
Application	X,Y,Z axes	Sweep rate = 60 minutes/axis

Table 14 Non-Operating
Vibration Specifications
(Packaged)

Vibration (Packaged)

Type	Random
Frequency Range	Truck Profile* (0.5 Grms) Air Profile* (1.0 Grms)
Application	X,Y,Z axes (30 minutes, each profile and each axis, for a total of 3 hours)
Type	Sine, Sweep, and Dwell
Frequency Range	5 to 150 to 5 Hz; 0.5 octave/minute, 0.5 G
Application	X,Y,Z axes; dwell at lowest resonant frequency in axis for 30 minutes. Additional 30 minutes for each additional resonance; up to 4 resonances total.

* Air and truck profiles are specified in ASTM D4728, Standard Test Method for Random Vibration Testing of Shipping Containers.

Table 15 Operating Shock and Vibration Specifications

Shock		
Pulse Shape	½ sine pulse	
Peak Acceleration	10 G	
Duration	10 ms	
Application	X,Y,Z axes, twice in each axis (once in each direction)	
Vibration		
Type	Sine	Sweep
Frequency Range	5 to 500 to 5 Hz	Upward and downward sweep
Acceleration Level	0.25 G 0.010" DA	Between 22 and 500 Hz Between 5 and 22 Hz (crossover)
Application	X,Y,Z axes	Sweep rate = 1.0 octave/minute

Current and Power Requirements

[Table 16](#) lists the current and power requirements for the two versions of the SDLT 600 tape drive system (internal and tabletop) configured with the SCSI interface. [Table 17](#) lists the current and power requirements for the internal version of the SDLT 600 tape drive system configured with the Fibre Channel interface. The library version of the SDLT 600 tape drive uses the same amount of power as the internal version with both the SCSI and Fibre Channel interfaces. The tabletop version requires AC power.

The tape drive draws the highest current (and power) during the native write modes. *Standby* is measured with the tape loaded and tensioned or untensioned, and *Idle* is measured with power on with no tape loaded.

(The power drawn in these two modes is similar enough that they are listed together.)

Note: In [table 16](#) and [table 17](#), the current and DC power values pertain to the internal tape drive, while the AC power values apply to the tabletop tape drive.

Table 16 Current and Power Requirements (SCSI Interface)

Mode	5 V Current (A)			12 V Current (A)			DC Power (W)		AC Power (W)	
	MaxPk ¹	MaxMean ²	Typ ³	MaxPk ¹	MaxMean ²	Typ ³	Max ⁴	Typ ⁵	Max ⁶	Typ ⁷
Standby/Idle	2.6	2.6	2.4	0.2	0.1	0.1	14	14	47	45
Media Loading/ Unloading	6.2	5.3	3.4	2.7	0.9	0.7	30	26	64	56
600 Write- Motor Start ⁸	4.3	4.0	3.7	1.3	0.3	0.3	23	22	51	48
600 Write- Streaming	5.4	5.1	4.9	0.7	0.5	0.4	30	30	65	63

Mode	5 V Current (A)			12 V Current (A)			DC Power (W)		AC Power (W)	
	MaxPk ¹	MaxMean ²	Typ ³	MaxPk ¹	MaxMean ²	Typ ³	Max ⁴	Typ ⁵	Max ⁶	Typ ⁷
Max for SDLT 600 tape drive Modes ⁹	n/a	5.3	n/a	n/a	0.9	n/a	30	n/a	70	n/a

1. The Max-Peak value represents short current spikes drawn for durations of < 50ms. On the 12V supply, the peaks correspond to the pulse-width-modulated switching of the motors. These values are calculated from the average of Peak-ripple-current + 2 sigma, measured at nominal DC voltage.
2. The Max-Mean value is the average of the maximum RMS current drawn during this operating mode. These values are calculated from the average of RMS current + 3 sigma, measured at nominal DC voltage.
3. The typical current is calculated from the average of all RMS current drawn during this operating mode, measured at nominal DC voltage.
4. The Max DC power is calculated from the typical DC power + 3 sigma, measured at nominal DC voltage. This value takes into account that the peak currents on the 5V and 12V do not occur at the same time.
5. The Typical DC power is calculated from the average RMS DC power drawn during this operating mode, measured at nominal DC voltage. This value also takes into account that the peak currents on the 5V and 12V do not occur at the same time.
6. The Max AC power is calculated from the typical AC power in tabletop tape drives + 3 sigma.
7. The Typical AC power is calculated from the average of AC power drawn in tabletop tape drives.
8. These events last < 1 second and occur at a duty cycle of less than 25%.
9. The Max values for each mode are based on the Max-Mean values, since the peak values are of very short duration.

(Common Notes)

- (1) Voltage tolerance: 5V ±5%, 12V ±5%; Room temperature 24 °C. AC power measured at 117 V, 60 Hz.
- (2) DC Current, MaxMean, and DC/AC Power Max refer to the statistically calculated maximum average requirement based on a sample population of tape drives. These values do not reflect the peak current or power requirement; this amount is given by the DC MaxPk current.

Table 17 Current and Power Requirements (Fibre Channel Interface)

Mode	5 V Current (A)			12 V Current (A)			DC Power (W)		AC Power (W)	
	MaxPk ¹	MaxMean ²	Typ ³	MaxPk ¹	MaxMean ²	Typ ³	Max ⁴	Typ ⁵	Max ⁶	Typ ⁷
Standby/Idle	3.5	3.5	3.1	0.2	0.1	0.1	18	17	n/a	n/a
Media Loading/Unloading	5.4	4.4	4.4	2.7	0.7	0.7	30	30	n/a	n/a
600 Write- Motor Start ⁸	4.6	4.3	4.2	1.3	0.3	0.3	25	25	n/a	n/a
600 Write- Streaming	5.9	5.6	5.5	0.7	0.5	0.4	33	33	n/a	n/a

Mode	5 V Current (A)			12 V Current (A)			DC Power (W)		AC Power (W)	
	MaxPk ¹	MaxMean ²	Typ ³	MaxPk ¹	MaxMean ²	Typ ³	Max ⁴	Typ ⁵	Max ⁶	Typ ⁷
Max for SDLT 600 tape drive Modes ⁹	n/a	5.6	n/a	n/a	0.7	n/a	33	n/a	n/a	n/a

1. The Max-Peak value represents short current spikes drawn for durations of < 50ms. On the 12V supply, the peaks correspond to the pulse-width-modulated switching of the motors. These values are calculated from the average of Peak-ripple-current + 2 sigma, measured at nominal DC voltage.
2. The Max-Mean value is the average of the maximum RMS current drawn during this operating mode. These values are calculated from the average of RMS current + 3 sigma, measured at nominal DC voltage.
3. The typical current is calculated from the average of all RMS current drawn during this operating mode, measured at nominal DC voltage.
4. The Max DC power is calculated from the typical DC power + 3 sigma, measured at nominal DC voltage. This value takes into account that the peak currents on the 5V and 12V do not occur at the same time.
5. The Typical DC power is calculated from the average RMS DC power drawn during this operating mode, measured at nominal DC voltage. This value also takes into account that the peak currents on the 5V and 12V do not occur at the same time.
6. The Max AC power is calculated from the typical AC power in tabletop tape drives + 3 sigma.
7. The Typical AC power is calculated from the average of AC power drawn in tabletop tape drives.
8. These events last < 1 second and occur at a duty cycle of less than 25%.
9. The Max values for each mode are based on the Max-Mean values, since the peak values are of very short duration.

(Common Notes)

- (1) Voltage tolerance: 5V ±5%, 12V ±5%; Room temperature 24 °C. AC power measured at 117 V, 60 Hz.
- (2) DC Current, MaxMean, and DC/AC Power Max refer to the statistically calculated maximum average requirement based on a sample population of tape drives. These values do not reflect the peak current or power requirement; this amount is given by the DC MaxPk current.

SDLT 600 Tape Drive System Recording Method

The SDLT 600 tape drive system uses the Partial Response Maximum Likelihood (PRML) 32/33 encoding method for reading/writing SDLT 600 tape drive format. It uses the same algorithm for reading SDLT 220, SDLT 320, and the DLT VS160 tape drive formats.

Environmental Specifications

The SDLT 600 tape drive system operates in environments that include general offices and work spaces with systems capable of maintaining standard comfort levels.

The following subsections provide the environmental specifications for the SDLT 600 tape drive systems (both the internal and the tabletop configurations). For long-term trouble-free operation, the manufacturer strongly recommends that SDLT 600 tape drives be used in a clean, smoke-free environment.

Air Flow Requirements

The internal tape drive requires adequate air flow to dissipate the heat resulting from continuous drive operation. Specifically, the air flow must be sufficient to keep the tape path temperature below 50 °C.

To allow enough air into the tape drive to keep the tape path below this temperature, it is important to keep the cooling holes in the rear and the grill in the front of the tape drive clear of any obstructions that may hinder the air flow. For more details about airflow, see the *SDLT 600 Design and Integration Guide (81-81196-xx)*.

Note: It is also important to limit the ambient air temperature to no greater than 40 °C.

Temperature and Humidity

The ambient operating environment for the tape drive may not exceed the limits shown in [table 18](#). (The specifications shown in the table are valid for both the internal and tabletop tape drives.)

Table 18 Temperature and Humidity Specification

Specification	Operating Limits	Non-Operating Limits (Power On, No Tape Loaded)
Wet Bulb Temperature	25 °C (77 °F)	25 °C (77 °F)
Dry Bulb Temperature Range	10 °C to 40 °C (50 °F to 104 °F)	10 °C to 40 °C (50 °F to 104 °F)
Temperature Gradient	11 °C (20 °F)/hour (across range)	15 °C (27 °F)/hour (across range)
Relative Humidity	20% to 80% (non-condensing)	10% to 90% (non-condensing)
Humidity Gradient	10%/hour	10%/hour

Storage and Shipment

The ambient storage and shipment environment for the tape drive may not exceed the limits shown in [table 19](#). (The specifications shown in the table are valid for both the internal and tabletop tape drives.)

Table 19 Tape Drive Storage and Shipment Specifications

Specification*	Storage (Unpacked or Packed)	Shipping
Wet Bulb Temperature	46 °C (114 °F)	46 °C (114 °F)
Dry Bulb Temperature	-40 °C to 66 °C (-40 °F to 150 °F)	-40 °C to 66 °C (-40 °F to 150 °F)
Temperature Gradient	20 °C (36 °F)/hour (across range)	20 °C (36 °F)/hour (across range)

Relative Humidity	10 to 95% (non-condensing)	10 to 95% (non-condensing)
Humidity Gradient	10%/hour	10%/hour
Note: These specifications apply to the tape drive only. Media specifications are listed in Recording Media Specifications .		

Altitude

Both the internal and tabletop tape drives operate in normal pressures from -500 to 10,000 feet when operated within the ambient operating environments specified in [Temperature and Humidity](#).

The SDLT 600 tape drive will operate to 30,000 feet for temperatures within 15 ± 5 °C.

Recording Media Specifications

Super DLTtape II media differs slightly from previous generations of Super DLTtape media. [Table 20](#) shows overall specifications for Super DLTtape II media.

Table 20 Super DLTtape II Media Specifications

Characteristic	Specification
Overall tape thickness	8.0 μm
Media length, total	2066 feet
Media length, usable	1957 feet

Media Structure

Super DLTtape II media comprises several layers, as shown in [figure 3](#).

Figure 3 Multiple Layers
Comprise Super DLTtape II
Media

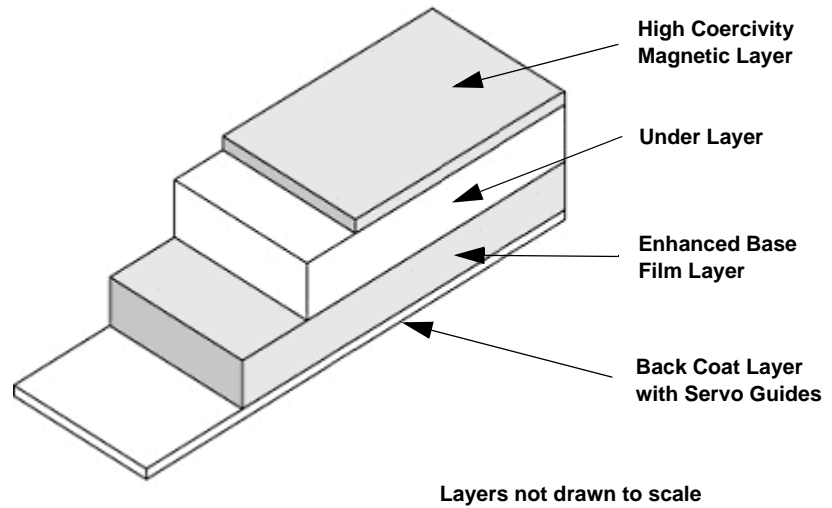

Physical Data Cartridge

A durable plastic case encloses the Super DLTtape II media, as shown in [figure 4](#).

Figure 4 Super DLTtape II
Data Cartridge

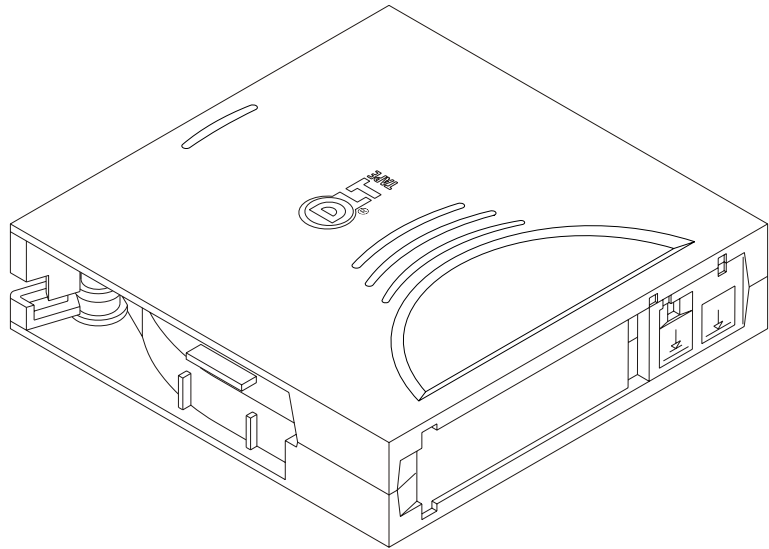

Media Shipping, Operating, and Storage Specifications

The optimum media shipping conditions are described in [table 21](#).

Table 21 Super DLTtape II
Media Shipping Limits

Shipping Conditions	
Temperature	-18 °C to 49 °C (0 °F to 120 °F)
Relative Humidity	20 to 80% (non-condensing)
Maximum Wet Bulb Temperature	26 °C (79 °F)
Maximum Dew Point	2 °C (36 °F)

Table 22 Super DLTtape II
Media Operating Limits

Operating Conditions	
Temperature	10 ° to 40 °C (50 ° to 104 °F)
Relative Humidity	20% to 80% (non-condensing)

[Table 23](#) describes the optimum media storage conditions.

Table 23 Super DLTtape II
Media Storage Limits

Storage Conditions	Archival	Non Archival
Temperature	18 ° to 28 °C (64 ° to 82 °F)	16 ° to 32 °C (60 ° to 90 °F)
Relative Humidity	40% to 60% (non-condensing)	20% to 80% (non-condensing)

**Backward-Read
Compatibility Transfer
Rates**

The SDLT 600 tape drive system features a backward-read compatibility (BRC) mode. When in BRC mode, the SDLT 600 tape drive is capable of reading SDLT 220 and SDLT 320 tape formats in a Super DLTtape I data cartridge, as well as the DLT VS160 tape format in the DLTtape VS1 data cartridge.

[Table 24](#) lists the BRC transfer rates for the SDLT 600 tape drive.

Table 24 SDLT 600 Tape Drive Backward-Read Compatibility (BRC) Transfer Rates

Format	Data Cartridge Type	Native Capacity	BRC Transfer Rate (80% of Native Read Transfer Rate)*
SDLT 320 Tape Drive	Super DLTtape I	160 GB	12.8 MB/sec**
SDLT 220 Tape Drive	Super DLTtape I	110 GB	8.8 MB/sec**
DLT VS160 Tape Drive	DLTtape VS1	80 GB	6.4 MB/sec**

* The manufacturer strives to operate BRC transfer rate at 100% of native read transfer rate, but guarantees 80%.

** Transfer rates shown are nominal based on 80% of actual native read transfer rate of uncompressed data.

Note: SDLT 600 tape drive will eject a data cartridge written in DLT formats other than DLT VS160.



Chapter 3 Installing Your Tape Drive

This chapter describes how to install the SDLT 600 tape drive. This includes configuration jumper settings, connector pin assignments, installation instructions, power and signal cabling descriptions, and operating instructions. This chapter also includes information on configuring and connecting the tabletop version of the tape drive into a system.

This chapter covers the following topics:

- [Warranty Note](#) provides a general reminder of certain precautions to follow so that you do not void your warranty.
- [Safety, Handling, and ESD Protection](#) describes appropriate safeguards to use when working with the SDLT 600 tape drive system.
- [Pre-Installation Guidelines](#) describes proper steps to take before installing the tape drive in a system. This includes recording the model and serial numbers, and checking that the proper SCSI (or Fibre Channel) controller and cable have been delivered.
- [Configuring and Installing an Internal Tape Drive with SCSI Interface](#) describes how to configure and install an internal tape drive with the SCSI interface into a system.
- [Configuring and Installing an Internal Tape Drive with Fibre Channel Interface](#) describes how to configure and install an internal tape drive with the Fibre Channel interface into a system.

- [Configuring and Installing a Tabletop Tape Drive with SCSI Interface](#) describes how to configure and install the tabletop version of the tape drive.
- [Confirming the Installation](#) describes how to confirm that the tape drive has been installed correctly.

Warranty Note

Please refer to the warranty before installing your tape drive. Certain actions taken during installation could void the warranty if not properly conducted.

Generally, the Limited Product and Limited Repair Warranties are contingent upon proper use in the application for which the product is intended; and do not cover the product if you perform any of the following actions:

- Modify the product without the manufacturer's written approval.
- Subject the product to unusual physical, environmental, or electrical stress, including damage caused by handling or shipping in unapproved containers or packaging.
- Disturb any warranty labels, or the integrity of the product in any other way.
- Remove or damage the serial number label to the extent that warranty status of the product cannot be determined.

Safety, Handling, and ESD Protection

Inappropriate or careless handling of SDLT 600 tape drive systems may result in damage to the product. Follow the precautions and directions to prevent damaging the SDLT 600 tape drive system. In addition, follow the steps in [Pre-Installation Guidelines](#) on page 41 to ensure that you have the correct hardware for your system configuration.

Safety Precautions

For your safety, follow all safety procedures described here and in other sections of the manual.

- 1 Power off the system before installing or removing the tape drive to prevent the possibility of electrical shock or damage to the tape drive. Unplug the unit that contains – or is to contain – the tape drive from AC power to provide an added measure of safety.
- 2 Read, understand, and observe all label warnings.
- 3 The POS uses a Class I laser product. This laser product complies with 29 CFR 1200 and 29 CFR 1910 as applicable on the date of manufacture.

Warning: If you open the tape drive chassis, you may become exposed to invisible laser emission which could be harmful if you are directly exposed to the beam.

Handling

Damage to the SDLT 600 tape drive system can occur as the result of careless handling, vibration, shock, or electrostatic discharge (ESD). For more details about ESD, see [Electrostatic Discharge Protection](#).

Caution: Always handle the SDLT 600 tape drive system with care to avoid damage to the precision internal components. Hold the internal tape drive by the sides, or the tabletop tape drive by the bottom. Never hold either tape drive by inserting fingers into the receiver area on the front of the tape drive. Damage to the receiver area may occur if you lift or carry it in this manner.

Follow these guidelines to avoid damage to the tape drive:

- Always observe prescribed ESD precautions.
- Keep the internal tape drive in its anti-static bag until ready to install.
- Always use a properly fitted wrist strap or other suitable ESD protection when handling the tape drive.
- Hold the internal tape drive only by its sides.
- Do not bump, jar, or drop the tape drive. Use care when transporting the tape drive.

- Always handle the tape drive carefully and gently. A drop of ¼ inch onto a bench or desktop may damage a tape drive.
- Never place the tape drive so that it rests on its front bezel. Always gently place the tape drive flat, printed circuit board (PCB) side down, on an appropriate ESD-protected work surface to avoid the tape drive being accidentally knocked over.
- Do not pack other materials with the tape drive in its anti-static bag.
- Place the tape drive in the anti-static bag before placing it in a shipping container.
- Do not stack objects on the tape drive.
- Do not expose the tape drive to moisture.
- Do not place foreign objects inside the tape drive's receiver area.

Electrostatic Discharge Protection

Several electrical components of the SDLT 600 tape drive system are sensitive to static electricity and electrostatic discharge (ESD). Even a static buildup or discharge that is too slight to feel can be sufficient to destroy or degrade a component's operation.

To minimize the possibility of ESD-related damage to the system, the drive's manufacturer strongly recommends using both a workstation anti-static mat and an ESD wrist strap. When correctly installed and properly used, these devices reduce the buildup of static electricity that might harm the system.

Observe the following precautions to avoid ESD-related problems:

- Leave the tape drive in its anti-static bag until you are ready to install it in the system.
- Always use a properly fitted and grounded wrist strap or other suitable ESD protection when handling the SDLT 600 tape drive system and observe proper ESD grounding techniques.
- Hold the tape drive only by its sides.
- Place the tape drive on a properly grounded anti-static work surface pad when it is out of its protective anti-static bag.
- Do not use the bag as a substitute for the work surface anti-static pad. The outside surface of the bag may not have the same anti-static properties as the inside surface. It could actually increase the possibility of ESD problems.

- Do not remove covers to use any test equipment to check components on the PCBAs. There are no user-serviceable components on the tape drive.

Pre-Installation Guidelines

Before you begin, check the contents of the box and record the applicable numbers. Since the tape drive may be *either* SCSI or Fibre Channel interface type (*never both*), check for SCSI (or Fibre Channel) controller and associated cable compatibility. Also confirm software and operating system compatibility. Finally, check the tape drive to be certain it is operating properly before installing it in a system.

- 1** Unpack and review the contents of the box for any physical damage. If you find damaged items, contact your tape drive provider.
- 2** Record the model and serial number of the SDLT 600 tape drive system. These numbers provide specific information about the SDLT 600 tape drive system and will be very helpful if you must contact technical support. You can find these numbers on the bottom of the tape drive enclosure.

The Model Number is a character string usually beginning with the letters "TR."

Model Number: TR_____

The Serial Number is a character string beginning with the letters "RB."

Serial Number: RB_____

- 3** Check the enclosed SCSI (or Fibre Channel) cable to ensure it is compatible with the SCSI (or Fibre Channel) controller card in the host computer.
- 4** Check the SCSI (or Fibre Channel) interface on the host computer to ensure that it is compatible with the tape drive. See [table 2](#) on page 16 for a list of the possible interfaces that are available and the various options with each. Remember that a single ended or low voltage differential tape drive will only work with a system that has an MSE controller card installed.

- 5 Confirm that your back-up software and operating system are compatible with the tape drive. See www.dlittape.com for the most up-to-date compatibility information.

Configuring and Installing an Internal Tape Drive with SCSI Interface

This section provides information for configuring and installing a tape drive with SCSI interface into a system. See [Configuring and Installing a Tabletop Tape Drive with SCSI Interface](#) on page 60 for information on configuring and installing a tabletop tape drive.

Caution: Before you begin, review the safety, ESD, and handling precautions described at the beginning of this chapter to avoid personal injury or damage to equipment.

Configuring the SDLT 600 tape drive system with SCSI interface includes the following tasks:

- Setting the SCSI ID for the tape drive (default = SCSI ID 5)
- Configuring the tape drive to provide TERMPWR
- Setting the configuration jumper (default = wide SCSI enabled).

If you want to change any of the settings, refer to the applicable subsection; otherwise proceed directly to the tape drive's installation procedures in [Installing the Internal SCSI Tape Drive](#) on page 47.

Setting the Internal Tape Drive SCSI ID

Each device on the SCSI bus must have a unique SCSI ID address assigned to it. For specific recommendations for assigning SCSI IDs, refer to your system or SCSI controller documentation.

Set the SCSI ID by using jumpers on a set of pins at the rear of the tape drive. This section discusses setting the SCSI ID on the internal tape drive via the jumper block. [Table 25](#) and [table 26](#) show the SCSI ID address and jumper settings.

[Figure 5](#) shows the empty 10-pin jumper block that you use to set the SCSI ID. [Figure 6](#) shows the location of the 10-pin SCSI ID block on the back of the tape drive.

If you decide it is necessary to change the tape drive's SCSI ID, use your fingers to move the jumpers to the pattern corresponding to the ID you want (see [figure 5](#) and the related table of SCSI jumper settings in [table 25](#) and [table 26](#)).

Figure 5 Detail of the Empty SCSI ID Jumper Block

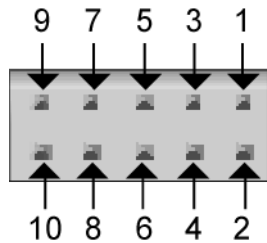









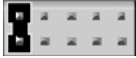







You can configure internal tape drives for SCSI ID addresses that range from 0 to 15 in one of two ways:

- Jumper the 10-pin SCSI ID block located on the back of the tape drive ([figure 6](#)).
- Set the SCSI ID through firmware in a library setting. (The firmware default = SCSI ID 5 and assumes no jumpers are installed on the jumper block.)

The default setting for the tape drive is 5; the host adapter setting is typically SCSI ID 7. If you choose to omit all jumpers from the SCSI ID block, the tape drive will use the default setting of 5.

Table 25 SCSI ID Address
 Selections (Graphical Format)

SCSI ID	0	1	2	3
Jumper Block				
SCSI ID	4	5 (default)	6	7
Jumper Block				
SCSI ID	8	9	10	11
Jumper Block				
SCSI ID	12	13	14	15
Jumper Block				

Note: The computer system and the tape drive SCSI IDs are only checked at power-on. To change the SCSI ID after installation, power off both the system and the tape drive, change the tape drive's SCSI ID, power on the tape drive, and then power on the system.

Figure 6 10-pin SCSI ID Jumper Block on Rear of Tape Drive

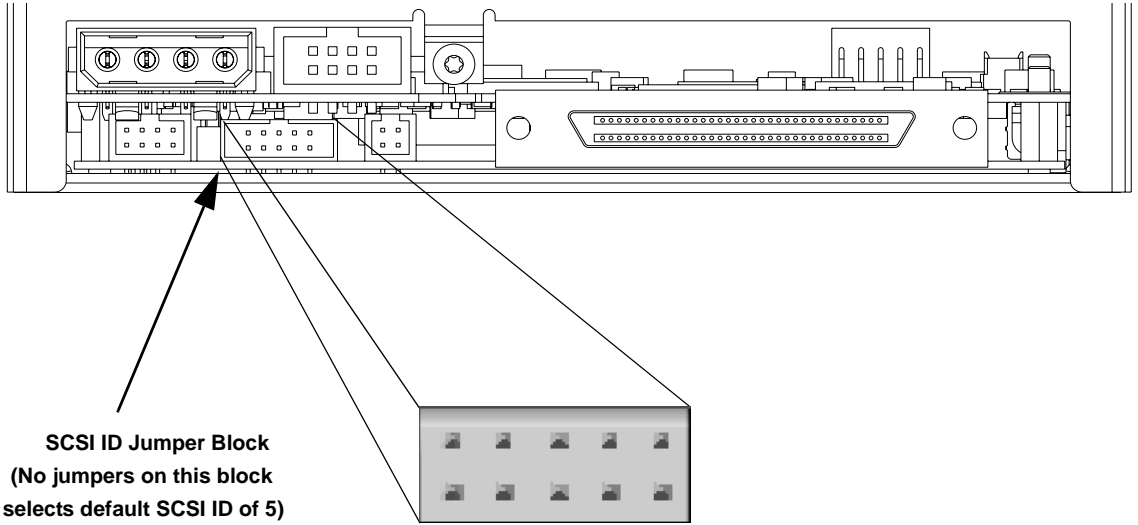

Table 26 SCSI ID Address Selections (Tabular Format)

SCSI ID	Jumper Across Pins				
	9-10*	7-8	5-6	3-4	1-2
0	1	0	0	0	0
1	1	0	0	0	1
2	1	0	0	1	0
3	1	0	0	1	1
4	1	0	1	0	0
5 (default)	0	0	0	0	0
6	1	0	1	1	0
7	1	0	1	1	1
8	1	1	0	0	0

SCSI ID	Jumper Across Pins				
	1	2	3	4	5
9	1	1	0	0	1
10	1	1	0	1	0
11	1	1	0	1	1
12	1	1	1	0	0
13	1	1	1	0	1
14	1	1	1	1	0
15	1	1	1	1	1

0 = No Jumper installed, 1 = Jumper installed

* Jumpering Pins 9-10 forces the tape drive to ignore the firmware value and read the value jumpered on the block.

Configuring the Internal SCSI Tape Drive for TERMPWR

You must terminate a SCSI bus at each end of the bus. Terminate all signals not defined as RESERVED, GROUND, or TERMPWR exactly once at each end of the bus. At least one device must supply terminator power (TERMPWR).

To enable TERMPWR, install the jumper across Pins 1 and 2 (see [figure 7](#)) on the TERMPWR jumper block. Remove the jumper to disable TERMPWR. Pins 3 and 4 on this block are reserved and require no jumper.

Figure 7 TERMPWR Jumper
Block on Rear of Tape Drive

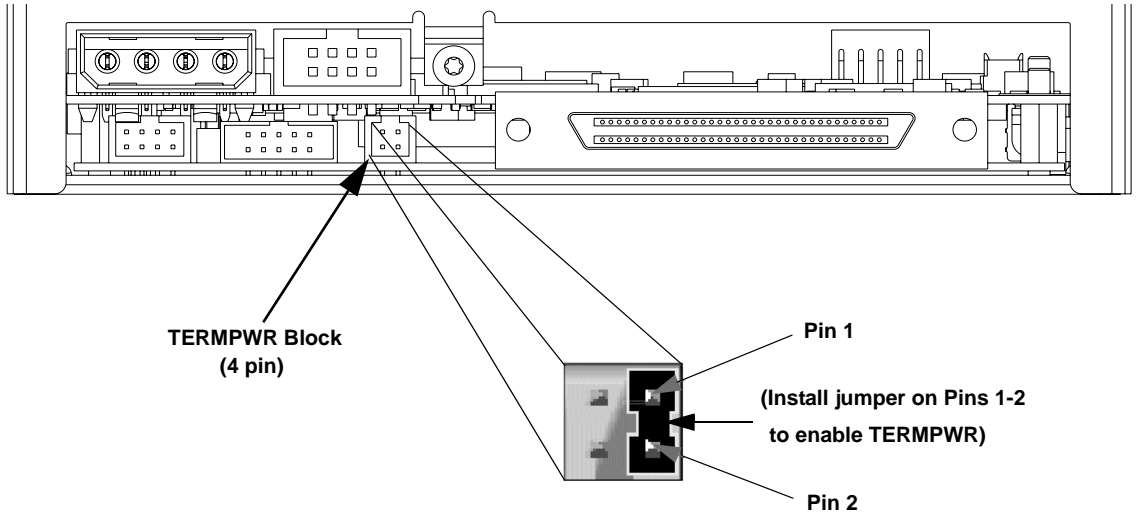

Installing the Internal SCSI Tape Drive

[Securing the Internal Tape Drive](#) describes installing the tape drive by securing the tape drive in its bay or chassis and connecting the SCSI bus (or Fibre Channel) and power cables. When you have finished mounting and installing the tape drive, proceed directly to [Confirming the Installation](#) on page 68 to confirm the installation.

[Figure 8](#) shows two perspective views of the internal tape drive.

Figure 8 Internal SCSI Tape Drive
Front and Rear View

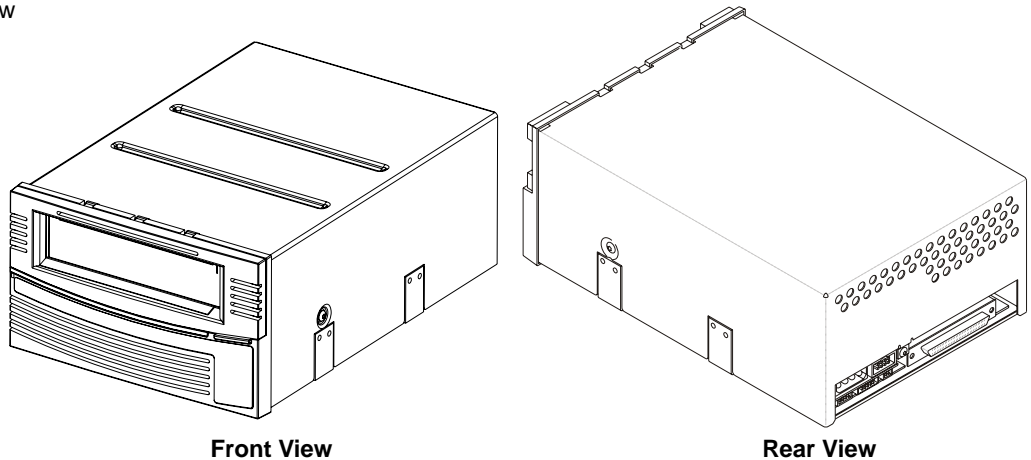

Securing the Internal Tape Drive

This section describes how to mount and secure the tape drive in the system.

Note: In some system configurations, it may be more convenient to connect the SCSI bus and power cables to the tape drive before securing it in the system.

Because of the variety of mounting possibilities for tape drives, the instructions presented here are general in nature. Use these instructions only as a guide for mounting the tape drive in your system.

Mount the tape drive in the system by performing the following steps:

- 1 Position the tape drive in the system and align the tape drive mounting holes (side or bottom) with those in the system. [Figure 9](#) shows the mounting locations and dimensions for the tape drive.

Caution: The screws used to mount the tape drive must be M3 x 8mm long. This type of screw is exactly the proper length and will not damage the tape drive.

- 2 Using four M3 x 8mm long screws, secure the tape drive in the bay or chassis.

Figure 9 Internal Tape Drive
 Mounting Locations – Front, Side,
 and Bottom Dimensions

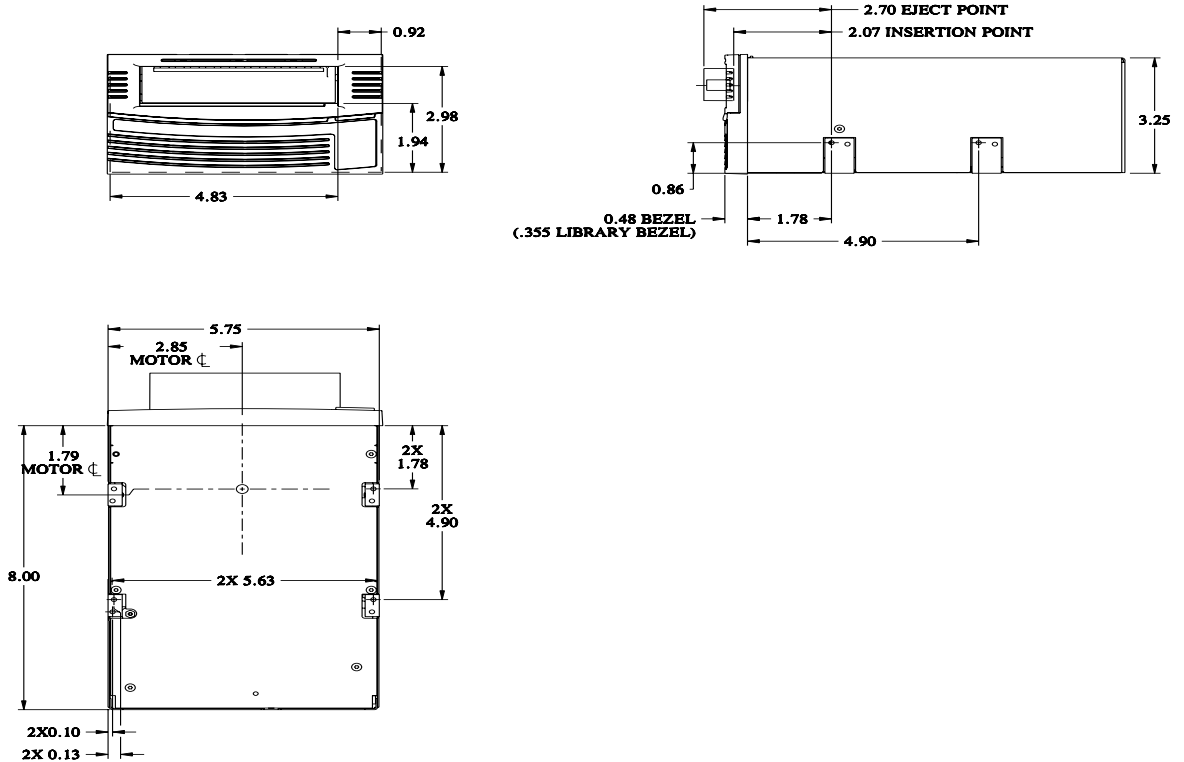

Connecting the Internal Tape Drive Cables

This section discusses three connectors on the back of the internal SDLT 600 tape drive: 1) SCSI, 2) power, and 3) optional library/loader connectors. [Figure 10](#) shows some typical AC power cord connectors used for the tabletop model.

SCSI and Power Connectors [Figure 13](#) on page 60 shows the pin orientation for the 68-pin SCSI connector and 4-pin power connector located on the back of the internal tape drive.

The tables list pin assignments for the two possible SCSI connectors: Multi-mode Single-Ended (MSE)/Single Ended (SE) mode in [table 27](#),

and MSE Low Voltage Differential (LVD) mode in [table 28](#) on page 53. Pin assignments for the power connector are listed in [table 29](#) on page 55.

- 1 Before connecting the SDLT 600 tape drive to the host computer, be certain the tape drive and computer are powered off.
- 2 Ensure that your SCSI cables and terminators are SPI-3 (or SPI-4) compatible. SPI refers to SCSI Parallel Interface; you can learn more about this standard at the Web site <http://www.t10.org>.
- 3 If you are connecting several devices to the SCSI bus, connect only the tape drive to the host computer at this time. Confirm that the host computer and tape drive are communicating correctly before adding additional devices.
- 4 The SCSI bus must be terminated at each end. You may need to terminate this tape drive if one of the following conditions exist:
 - The SDLT 600 tape drive is the only device connected to the SCSI bus.
 - The SDLT 600 tape drive is one of several devices connected to the SCSI bus, and it is the last device connected to the SCSI bus.
- 5 If either condition exists in step 4, attach a Y adaptor cable to the tape drive's SCSI connector; then attach the SCSI cable to one leg of the "Y" and attach the terminator to the other leg. Carefully connect the cables, to avoid bending or damaging the connector pins.

Note: You must supply the Y adaptor cable to connect both the SCSI connector and the terminator to the tape drive.

- 6 Attach the power cables to the tape drive. Check the SCSI cable and termination connections and ensure that they are attached correctly and seated firmly.

Optional Loader Connector

The 8-pin optional loader connector provides signals to be used when the tape drive is part of a loader/library configuration. [Figure 11](#) on page 57 shows the location of this connector; [Table 30](#) on page 55 lists the pin assignments for the loader connector.

Figure 10 Connectors on the Rear Panel of Internal SCSI Tape Drive

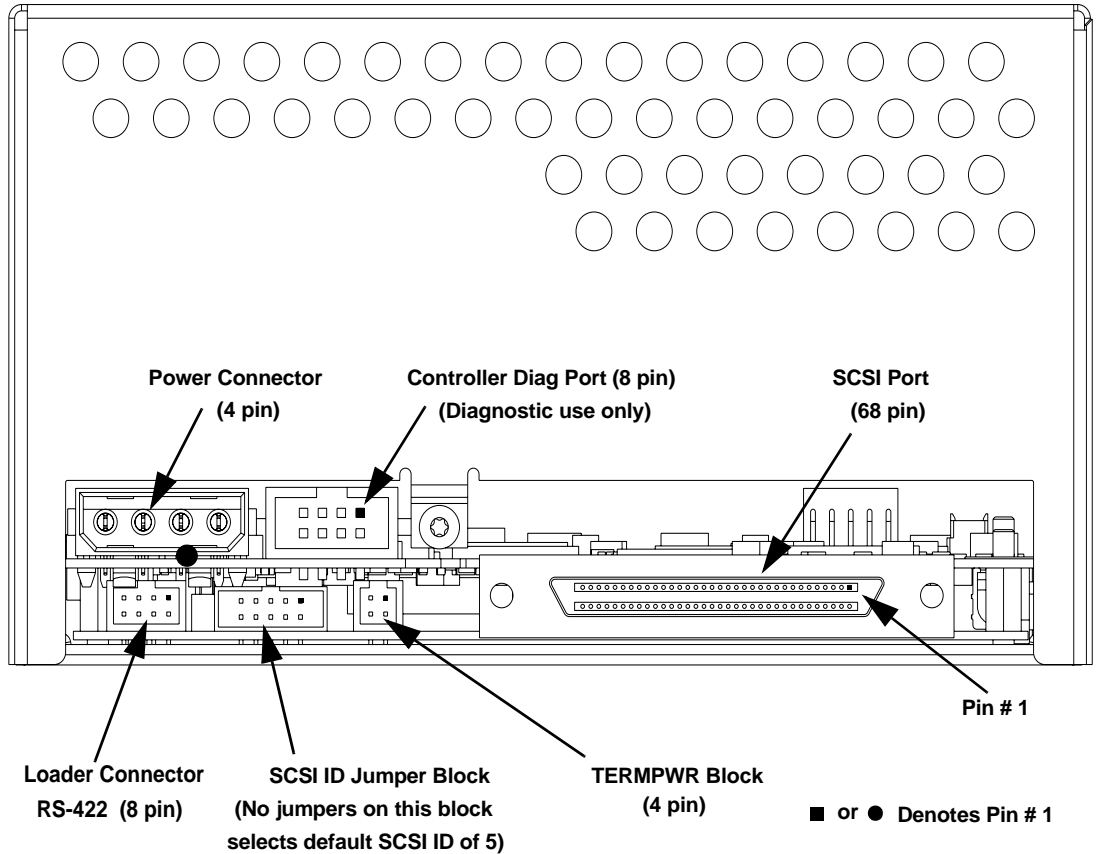

Table 27 MSE and SE
 Mode SCSI Connector Pin
 Assignments

Signal Name	Pin Number	Pin Number	Signal Name
Ground	1	35	-DB(12)
Ground	2	36	-DB(13)
Ground	3	37	-DB(14)
Ground	4	38	-DB(15)
Ground	5	39	-DB(P1)
Ground	6	40	-DB(0)
Ground	7	41	-DB(1)
Ground	8	42	-DB(2)
Ground	9	43	-DB(3)
Ground	10	44	-DB(4)
Ground	11	45	-DB(5)
Ground	12	46	-DB(6)
Ground	13	47	-DB(7)
Ground	14	48	-DB(P0)
Ground	15	49	Ground
DIFFSENS	16	50	Ground
TERMPWR	17	51	TERMPWR
TERMPWR	18	52	TERMPWR
Reserved	19	53	Reserved
Ground	20	54	Ground
Ground	21	55	-ATN
Ground	22	56	Ground
Ground	23	57	-BSY
Ground	24	58	-ACK

Signal Name	Pin Number	Pin Number	Signal Name
Ground	25	59	-RST
Ground	26	60	-MSG
Ground	27	61	-SEL
Ground	28	62	-C/D
Ground	29	63	-REQ
Ground	30	64	-I/O
Ground	31	65	-DB(8)
Ground	32	66	-DB(9)
Ground	33	67	-DB(10)
Ground	34	68	-DB(11)

Note: The minus sign (-) next to a signal indicates active low.

Table 28 MSE LVD SCSI
 Connector Pin Assignments

Signal Name	Pin Number	Pin Number	Signal Name
+DB(12)	1	35	-DB(12)
+DB(13)	2	36	-DB(13)
+DB(14)	3	37	-DB(14)
+DB(15)	4	38	-DB(15)
+DB(P1)	5	39	-DB(P1)
+DB(0)	6	40	-DB(0)
+DB(1)	7	41	-DB(1)
+DB(2)	8	42	-DB(2)
+DB(3)	9	43	-DB(3)
+DB(4)	10	44	-DB(4)
+DB(5)	11	45	-DB(5)

Signal Name	Pin Number	Pin Number	Signal Name
+DB(6)	12	46	-DB(6)
+DB(7)	13	47	-DB(7)
+DB(P)	14	48	-DB(P)
Ground	15	49	Ground
DIFFSENS	16	50	Ground
TERMPWR	17	51	TERMPWR
TERMPWR	18	52	TERMPWR
Reserved	19	53	Reserved
Ground	20	54	Ground
+ATN	21	55	-ATN
Ground	22	56	Ground
+BSY	23	57	-BSY
+ACK	24	58	-ACK
+RST	25	59	-RST
+MSG	26	60	-MSG
+SEL	27	61	-SEL
+C/D	28	62	-C/D
+REQ	29	63	-REQ
+I/O	30	64	-I/O
+DB(8)	31	65	-DB(8)
+DB(9)	32	66	-DB(9)
+DB(10)	33	67	-DB(10)
+DB(11)	34	68	-DB(11)

Table 29 4-Pin Power
 Connector Pin Assignments

Pin Number	Signal Name
1	+12 VDC
2	Ground (+12V return)
3	Ground (+5V return)
4	+5 VDC

Table 30 8-Pin Loader
 Connector Pin Assignments

Signal Name	Pin Number	Pin Number	Signal Name
Ground	1	5	SEND_TO_LOADER_H
REC_FROM_LOADER_H	2	6	SEND_TO_LOADER_L
REC_FROM_LOADER_L	3	7	Ground
Ground	4	8	LOADER_PRESENT_L

Configuring and Installing an Internal Tape Drive with Fibre Channel Interface

This section provides information for configuring and installing a tape drive with the Fibre Channel interface into a system.

Fibre Channel Introduction

Fibre Channel is the name of an integrated set of standards developed by the American National Standards Institute (ANSI). The intention of the Fibre Channel specification is to develop a practical, inexpensive, yet expandable means of quickly transferring data between workstations, mainframes, supercomputers, desktop computers, storage devices, display terminals, and other peripherals.

Fibre Channel is an open T11 and ANSI standard based on a block-oriented serial network protocol that brings together some of the best features of the channel world and the network world. Fibre Channel is full-duplex (meaning that data can travel in both directions simultaneously), and offers a variety of different cabling options.

Fibre Channel is a high performance serial link transport protocol that supports higher level protocols such as the FDDI, SCSI, HIPPI, and IPI. Fibre Channel addresses the need for very fast transfers of large amounts of information. The majority of Fibre Channel devices available in the market today operate at speeds of 1 to 2 Gb/s.

For complete information on how Fibre Channel is implemented in the Quantum SDLT 600 tape drive, see the *SDLT 600 Fibre Channel Interface Guide (81-81202-xx)*.

Note: Fibre Channel interface is ONLY available with the internal model, it is not available with the tabletop model.

Caution: Before you begin, review the safety, ESD, and handling precautions described in [Safety, Handling, and ESD Protection](#) on page 38 to avoid personal injury or damage to equipment.

[Figure 11](#) shows the SDLT 600 Fibre Channel connectors and jumper blocks located on the rear of the unit.

Figure 11 Internal Fibre Channel
Tape Drive Connectors and
Jumpers

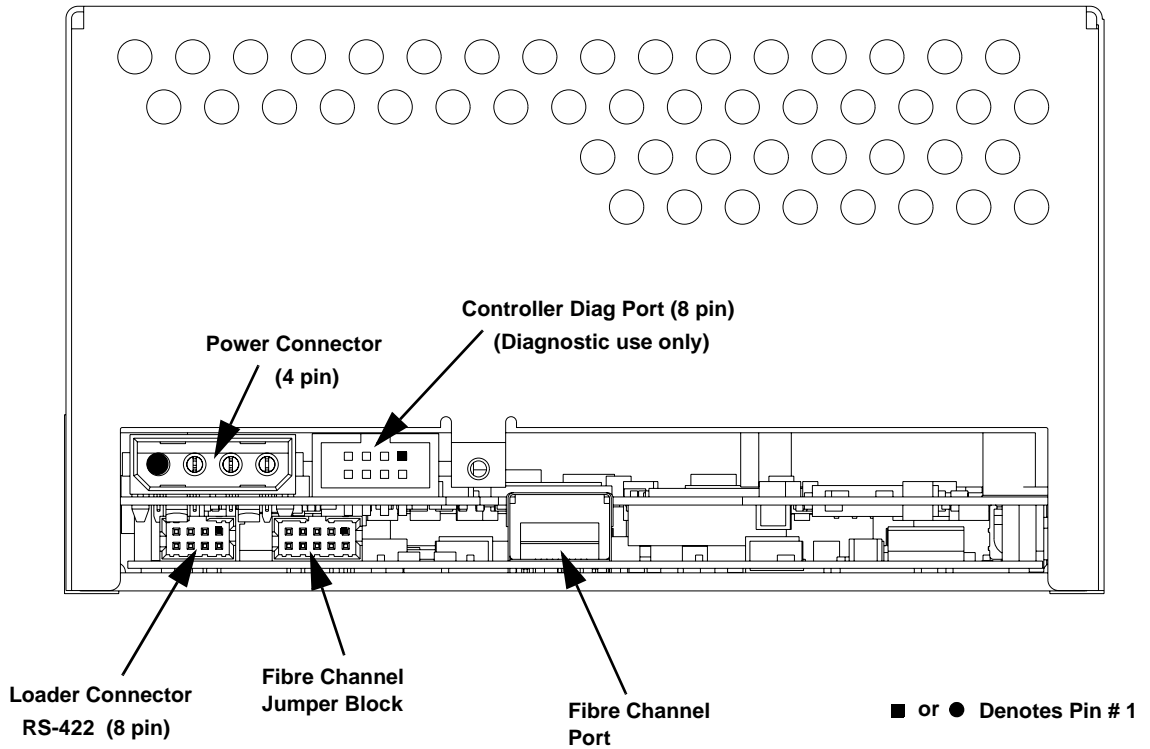

Follow these steps to connect a Fibre Channel tape drive:

- 1 Secure the tape drive.
- 2 Connect the power.
- 3 Connect the library/loader (optional).
- 4 Connect the Fibre Channel cable.

Each of these steps is discussed in the subsections that follow.

Secure the Tape Drive

This section describes how to mount and secure the tape drive in the system.

Note: In some system configurations it may be more convenient to connect the Fibre Channel and power cables to the tape drive before securing it in the system.

Because of the variety of mounting possibilities for tape drives, the instructions presented here are general in nature. Use them only as a guide for mounting the tape drive in your system.

Mount the tape drive in the system by performing the following steps:

- 1 Make sure the host computer and all peripheral devices are powered off.
- 2 Position the tape drive in the system and align the mounting holes (side or bottom) with those in the system. [Figure 9](#) on page 49 shows the mounting locations and dimensions for the tape drive.

Caution: The screws used to mount the tape drive must be M3 x 8mm long. This type of screw is exactly the proper length and will not damage the tape drive.

- 3 Using four M3 x 8mm long screws, secure the tape drive in the bay or chassis.

Connect the Power

[Figure 11](#) shows the location of this connector; pin assignments for the power connector are listed in [table 29](#) on page 55.

- 1 Before connecting the SDLT 600 tape drive to the host computer, be certain the tape drive and computer are powered off.
- 2 If you are connecting several devices to the system, connect only the tape drive to the host computer at this time. Confirm that the host computer and tape drive are communicating correctly before adding additional devices.
- 3 Attach the power cable to the tape drive.
- 4 Check all cable and termination connections and ensure that they are attached correctly and seated firmly before you power on the system.

Optional Loader Connector

The 8-pin optional loader connector provides signals to be used when the tape drive is part of a loader/library configuration. [Figure 11](#) shows the location of this connector; [table 30](#) on page 55 lists pin assignments for the loader connector.

Note: When connecting to the Fibre Channel port, make sure to use a 50 μ M Fiber core fiber optic cable with an LC, Duplex connector.

Connect the Fibre Channel Cable

- 1 Fibre Channel cables are **hot-swappable**—meaning you may connect and disconnect them with unit power on. Therefore, unlike other systems, the tape drive and computer may remain on to connect the SDLT 600 tape drive to the host computer.
- 2 Insert the fiber optic cable into the Fibre Channel port on the back of the tape drive as shown in [figure 12](#). The connector is fully seated when it snaps into the port.

Figure 12 Connecting the Fiber Optic Cable

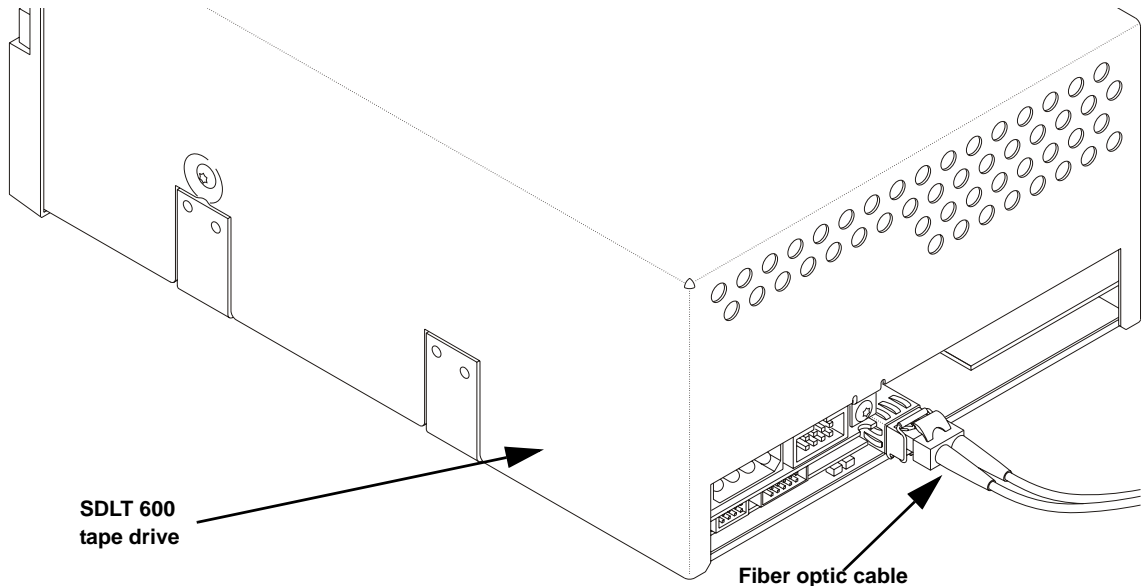

Configuring and Installing a Tabletop Tape Drive with SCSI Interface

This section provides instructions for configuring and installing the tabletop SCSI model of the SDLT 600 tape drive.

Configuring the SCSI Tape Drive

[Figure 13](#) shows the location of the controls and connectors for the tabletop tape drive. This model of tape drive is normally configured to meet customer specifications before leaving the factory, so should not require any internal configuration changes on site.

Figure 13 Rear Panel of the SCSI Tabletop Model

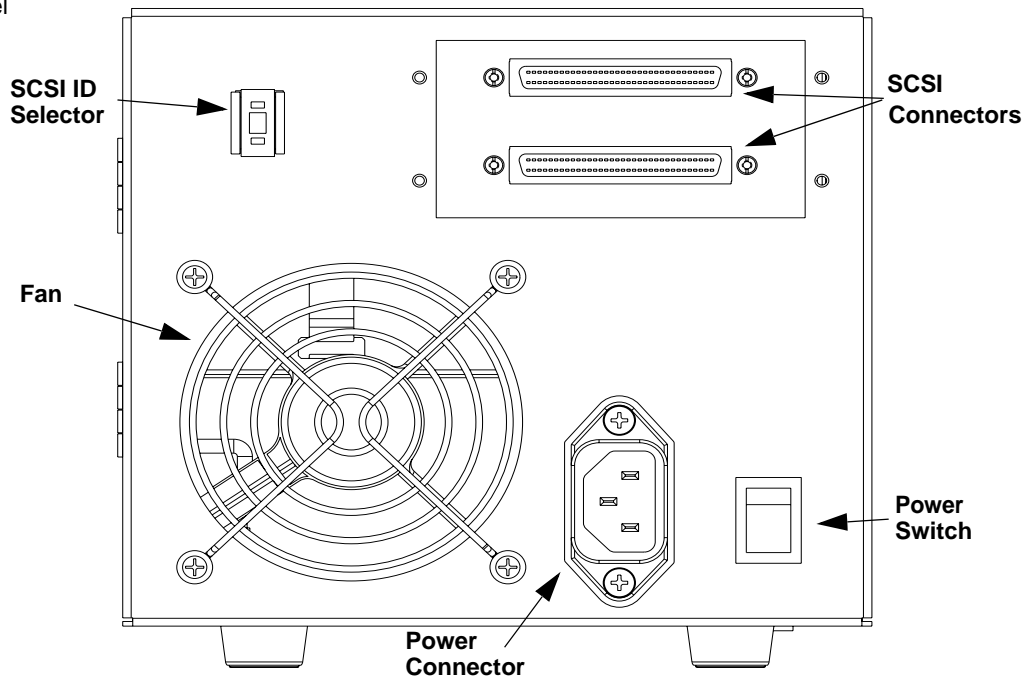

SCSI ID

The SCSI ID default for the tabletop tape drive is set to 3; you can configure the tape drive for SCSI ID addresses that range from 0 to 15 using the SCSI ID pushbutton. Press the button above or below the ID number display to set the desired SCSI ID. The top button increases the ID number, the bottom button decreases the ID number. [Figure 14](#) shows a close-up view of the SCSI ID switch and its location on the rear of the tabletop model of the SDLT 600 tape drive.

Figure 14 SCSI ID Selector Switch for the SCSI Tape Drive Tabletop Model

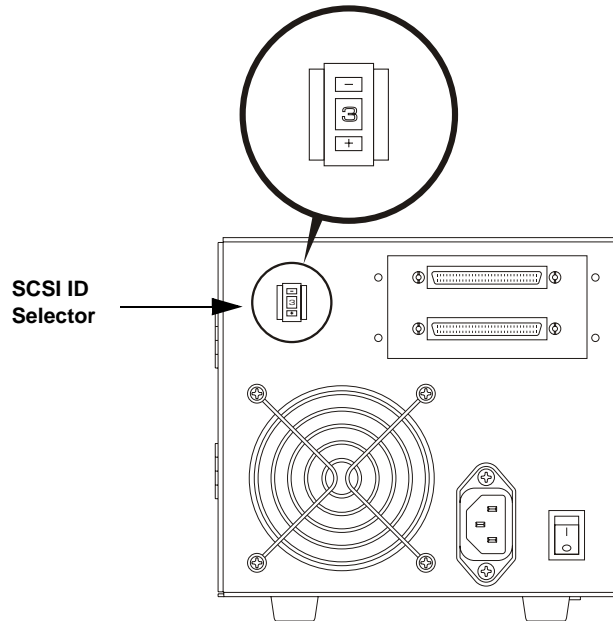

TERMPWR

The factory preconfigures the TERMPWR setting for the tabletop tape drive according to specific customer requirements. You can not select TERMPWR on site.

Installing the SCSI Tabletop Tape Drive

Tabletop tape drive installation consists of connecting SCSI bus and power cables.

[Figure 13](#) shows the location of the two SCSI bus connectors and power connector on the back of the tabletop tape drive.

SCSI Cables

You can connect the SCSI bus cable leading from the host adapter to either of the tape drive SCSI connectors. If the tape unit is the last device on the bus, then you should install a SCSI terminator on the open connector. If the bus continues from the tape drive to another SCSI device, then install a SCSI bus cable between the open connector and the next device on the bus. [Figure 15](#) illustrates these two connection methods.

Figure 15 Cabling Options for the SCSI Tape Drive Tabletop Model

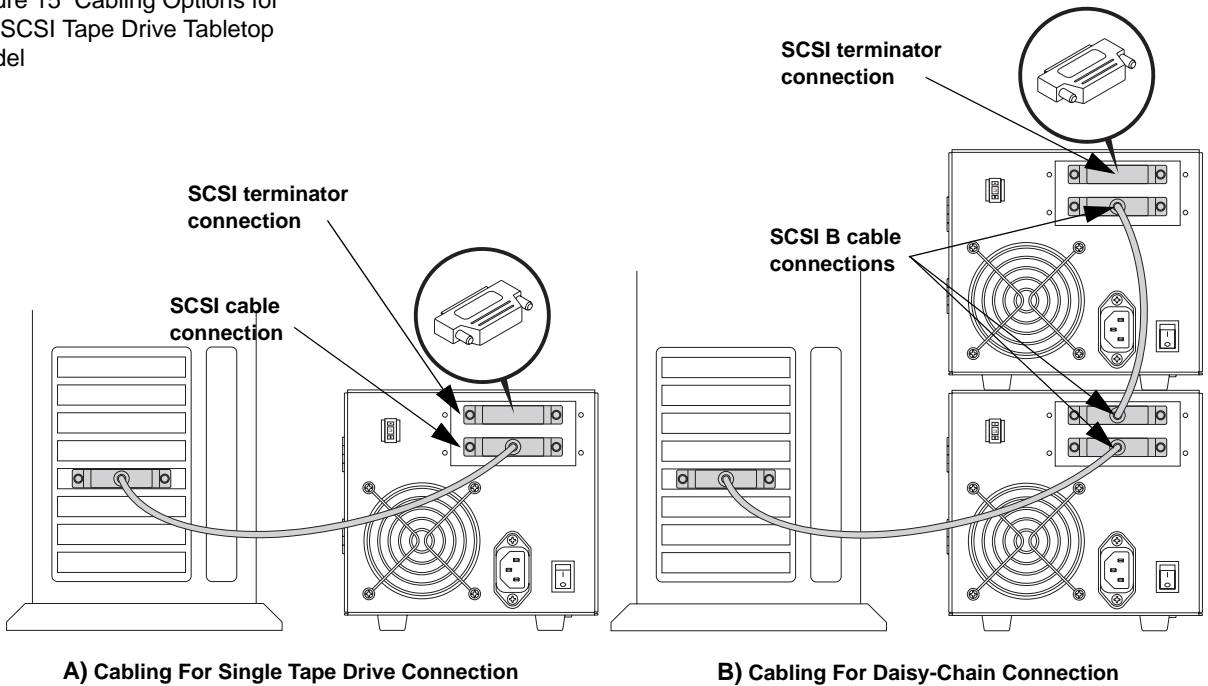

- 1 Prior to connecting the SDLT 600 tape drive to the host computer, be certain the tape drive and computer are turned off.
- 2 If you are connecting several devices to the SCSI bus, connect only the tape drive to the host computer at this time. Confirm that the host computer and tape drive are communicating correctly before adding additional devices.
- 3 You must terminate the SCSI bus at each end. To install the SCSI terminator, place it into the unused SCSI connector on the rear of the tabletop tape drive and tighten the screws to secure it.
 - If the SDLT 600 tape drive is the only device connected to the SCSI bus, attach the SCSI terminator to one of the connectors on the back of the tape drive (see [figure 15, A](#)).
 - If the SDLT 600 tape drive is one of several devices connected to the SCSI bus, and it is the last device connected to the SCSI bus, attach the SCSI terminator to one of the connectors on the back of the tape drive (see [figure 15, B](#)).
- 4 Align the appropriate SCSI cable to its matching connector on the tape drive. Carefully connect the cable, to avoid bending or damaging the connector pins. Check the SCSI cable and termination connections and ensure that they are attached correctly and seated firmly.
- 5 Snap the wire cable clamps into place to secure the cables.

AC Power Cable

An AC power cord is supplied with each tabletop unit. Carefully inspect the power cord and ensure that the cord is the appropriate cord for your country or region based on the criteria below.

Warning: Do not attempt to modify or use a tabletop 100–115 V AC power cord for 220–240 V AC input power. Modifying the power cord in any way can cause personal injury and severe equipment damage.

The AC power cord used with the tabletop unit must meet the following criteria:

- The power cord should be a minimum of 18/3 AWG, 60 °C, type SJT or SVT.

- UL and CSA certified cordage rated for use at 250 VAC with a current rating that is at least 125% of the current rating of the product.
- You must terminate the AC plug in a grounding-type male plug designed for use in your country or region. It must also have marks showing certification by an agency acceptable in your country or region.
- The tabletop unit cord connector must be an IEC type CEE-22 female connector.
- The cord must be no longer than 4.5 meters (14.5 feet).
- The cord must be FCC compliant with emissions specifications.

[Figure 16](#) shows the AC power cord plug-end types for 115 VAC and 220/240 VAC usage.

Figure 16 AC Power Cord Connector Types

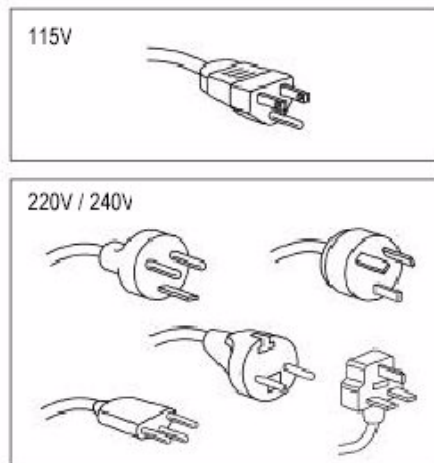

The tabletop unit power supply has an auto-sensing feature; it requires no adjustment or switch setting changes for different AC sources.

See [figure 13](#) on page 60 and [figure 16](#) for more details for the AC cord and AC cord connector. Connect one end of the AC cord into the power connector on the back of the tabletop tape drive; connect the other end of the cord to the AC outlet. Upon completion, proceed to the next section to confirm the installation.

Configuring and Installing a Tabletop Tape Drive with SCSI Interface

This section provides instructions for configuring and installing the tabletop Fibre Channel model of the SDLT 600 tape drive.

Tabletop Fibre Channel Tape Drive Model

Follow these steps to connect a tabletop Fibre Channel SDLT 600 tape drive:

- 1 Prior to connecting the SDLT 600 tape drive to the host computer, be certain the tape drive and computer are turned off.
- 2 Remove the Fibre Channel protective caps from the rear of the drive.
- 3 Remove the fiber optic cable protective caps and insert the fiber optic cables into the Fibre Channel connector, as shown in [figure 17](#). The connector is fully seated when it snaps into the port.

Note: You can connect a Fibre Channel connector while the tape drive is still powered on; this capability is known as “hot-swappable” or hot-pluggable.”
When connecting to the Fibre Channel port, make sure to use a 50µM Fiber core fiber optic cable with an LC, Duplex connector.

Figure 17 Connecting the Fiber Optic Cable to a Tabletop Fibre Channel Tape Drive

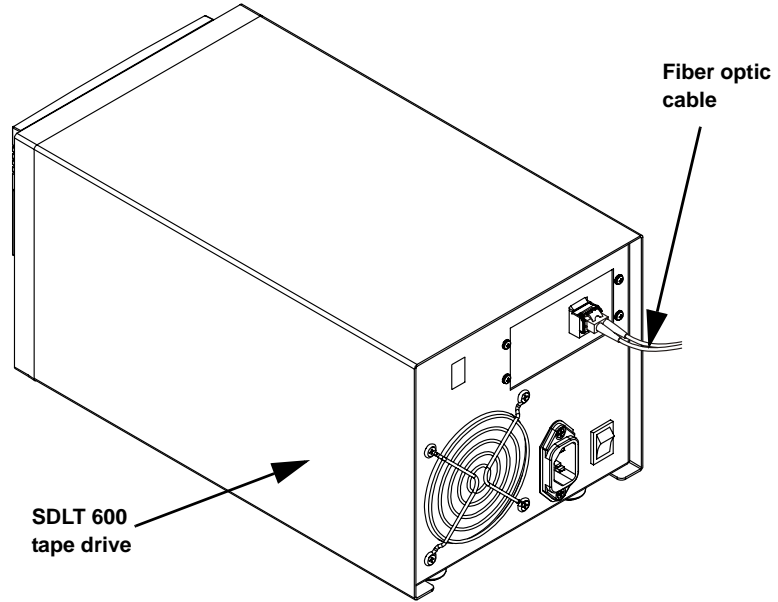

AC Power Cable

An AC power cord is supplied with each tabletop unit. Carefully inspect the power cord and ensure that the cord is the appropriate cord for your country or region based on the criteria below.

Warning: Do not attempt to modify or use a tabletop 100–115 V AC power cord for 220–240 V AC input power. Modifying the power cord in any way can cause personal injury and severe equipment damage.

The AC power cord used with the tabletop unit must meet the following criteria:

- The power cord should be a minimum of 18/3 AWG, 60 °C, type SJT or SVT.
- UL and CSA certified cordage rated for use at 250 VAC with a current rating that is at least 125% of the current rating of the product.

- You must terminate the AC plug in a grounding-type male plug designed for use in your country or region. It must also have marks showing certification by an agency acceptable in your country or region.
- The tabletop unit cord connector must be an IEC type CEE-22 female connector.
- The cord must be no longer than 4.5 meters (14.5 feet).
- The cord must be FCC compliant with emissions specifications.

[Figure 18](#) shows the AC power cord plug-end types for 115 VAC and 220/240 VAC usage.

Figure 18 AC Power Cord Connector Types

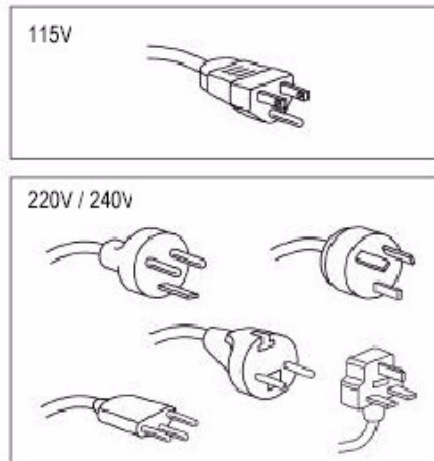

The tabletop unit power supply has an auto-sensing feature; it requires no adjustment or switch setting changes for different AC sources.

See [figure 17](#) and [figure 18](#) for more details for the AC cord and AC cord connector. Connect one end of the AC cord into the power connector on the back of the tabletop tape drive; connect the other end of the cord to the AC outlet. Upon completion, proceed to the next section to confirm the installation.

Confirming the Installation

To confirm the installation, power on the SDLT 600 tape drive system and the host computer. The screens displayed at power-on contain BIOS, operating system, and SCSI controller information. If the first screen displays host adapter and SCSI ID information, then the installation is successful. See [Troubleshooting](#) on page 80 if the installation is not successful.

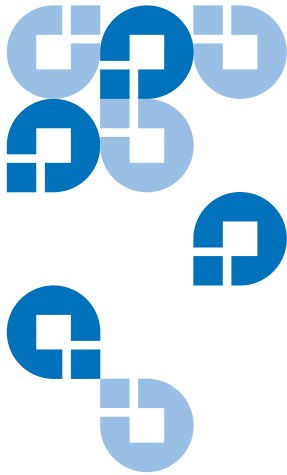

Using Your Tape Drive

This chapter describes how to start using your SDLT 600 tape drive system. This includes making a trial back-up, cleaning the tape mechanism, and various troubleshooting information. This chapter also includes information on the LEDs and buttons on the front panel of the system.

This chapter covers the following topics:

- [Power-On Self-Test](#) describes the sequence of activities that occur when power is first applied to the tape drive.
- [Performing a Trial Back-up](#) describes how to back up a sample file to ensure proper operation of the system.
- [Updating the Firmware](#) describes how to update the firmware (microcode) that resides inside the tape drive and controls its behavior.
- [Cleaning the Tape Mechanism](#) describes the considerations to keep in mind when using SDLT cleaning tapes.
- [Front Panel Controls and LEDs](#) describes the functionality of the front panel controls and LEDs.
- [Troubleshooting](#) lists troubleshooting tips and diagnostic tools to use if the tape drive system fails.

Power-On Self-Test

The SDLT 600 tape drive system performs a Power-On Self-Test (POST) each time the tape drive is powered on. POST normally completes in 10 to 15 seconds—when a data cartridge is not in the tape drive—when the unit is powered on. However, if a data cartridge is in the tape drive when the unit is powered on, POST duration is longer, depending on how much tape in the data cartridge may be loaded in the tape drive.

While POST is running, the SDLT 600 tape drive system responds BUSY to SCSI commands. The SDLT 600 tape drive system also responds to various SCSI messages during POST.

During this time, if a host tries to negotiate Synchronous or Wide transfers, the SDLT 600 tape drive system negotiates to Asynchronous or Narrow. It may take longer than the duration of POST for the tape drive to become ready.

[Table 31](#) provides the sequence of operation to expect when power is turned on. See [figure 19](#) to help familiarize yourself with the LEDs on the front panel.

Table 31 LED Lighting Pattern During Power-On Self-Test (POST)

Stage	What You Observe
1 (Power On)	All LEDs illuminate for approximately one second.
2	The LEDs flash on, then off in a progressing pattern from left to right. Stages 1 and 2 generally complete within approximately five seconds.
3	The right LEDs remain off, the left LED illuminates steadily, and the middle LED flashes until POST completes. This stage typically lasts for 5 to 10 seconds.
4	When POST is complete, the middle LED stops flashing and remains illuminated; the left LED turns off, and right LED remains off.
POST Failure	If POST fails, the middle and right LEDs illuminate steadily and the left LED flashes.

Stage	What You Observe
Note:	If a data cartridge is in place when power is turned on, all stages remain the same except stage 3. It may take a considerably longer time for stage 3 to complete due to tape rewind and searching operations that occur during that stage.

Figure 19 Front Panel LEDs

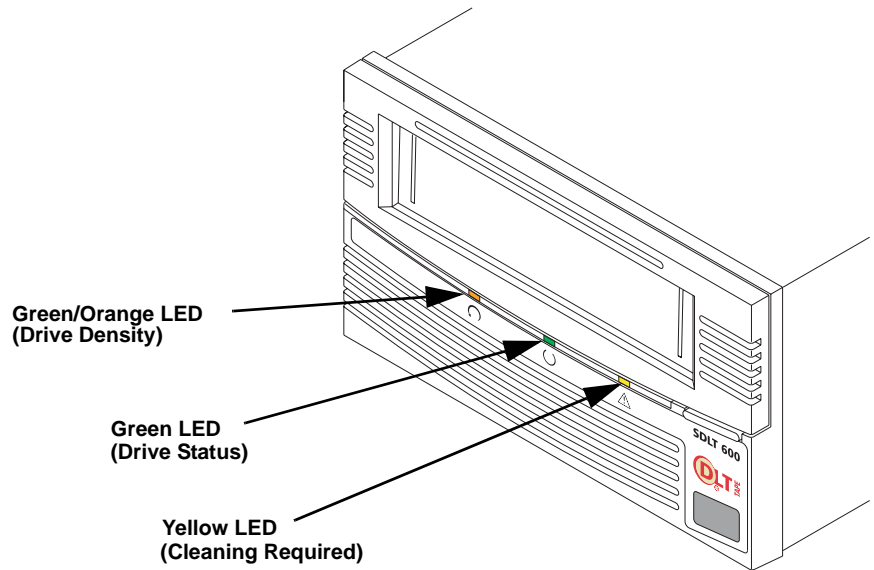

Performing a Trial Back-up

Complete the following steps to perform a trial backup and verify correct tape drive installation:

- Insert a data cartridge. Push the data cartridge completely into the system. The tape will load automatically.
- Choose a sample file set from the host computer.
- Create a backup file and then restore the file set. If the backup file completely restores, without any errors, you installed the system correctly.

- If you experience errors, doublecheck the tape drive's configuration and setup, using the ideas provided in [Troubleshooting](#) on page 80.
- After you have exhausted all troubleshooting alternatives, contact your service representative.
- Press the **Eject** button to unload the data cartridge. If you are unsure which button is the **Eject** button, see [figure 20](#) on page 77.

Note: You can review specific instructions for loading a data cartridge in the [appendix A, Super DLTtape I and Super DLTtape II Data Cartridges](#) and [appendix B, DLTtape VS1 Data Cartridge](#).

Updating the Firmware

When you need to update the firmware in a tape drive, you can do it either of two ways:

- By directly using the SCSI bus
- By creating a firmware image data cartridge (CUP/FUP) to use in either a manual firmware update or in a library setting.

DLTSage provides the tool that allows you to update the tape drive's firmware using the SCSI bus, or to create a CUP/FUP data cartridge for an SDLT 600 tape drive. DLTSage is available on the Quantum Web site, <http://www.quantum.com>. [Quantum Diagnostics Tools](#) on page 10 in [provides details on locating DLTSage in the Quantum Web site](#).

The following subsections briefly describe both methods of updating the tape drive firmware.

Update the Firmware Using the SCSI Bus

Quantum provides upgrades for product software and firmware that may be newly developed. These updates are available on the Quantum Web site.

Note: These tools are only available to registered Quantum customers.

Refer to the following procedure to access and download these updates.

- 1 Go to the Quantum Web site: <http://www.quantum.com>.
- 2 Click **SERVICE AND SUPPORT** in the upper menu bar. This opens the Service and Support window.
- 3 Explore the various pages that comprise Service and Support until you find the update you need.
- 4 Download the DLTSage package and refer to that tool's built-in online help for detailed instructions to use while updating the firmware.

Create a CUP/FUP Data Cartridge

To update your tape drive firmware you may create a CUP/FUP data cartridge from the update information found on the Quantum Web site.

<p>Note: These tools are only available to registered Quantum customers.</p>

Refer to the following procedure to access these updates for creating a CUP/FUP data cartridge.

- 1 Go to the Quantum Web site: <http://www.quantum.com>.
- 2 Click **SERVICE AND SUPPORT** in the upper menu bar. This opens the Service and Support window.
- 3 Explore the various pages that comprise Service and Support until you find the update you need.
- 4 Download the DLTSage package and refer to that tool's built-in online help for detailed instructions about how to create the data cartridge.

Using a CUP/FUP Data Cartridge

Follow these steps to use a CUP/FUP data cartridge:

- 1 Verify that the tape drive is turned on (power is applied), and the middle (Drive Status) LED on the front panel of the tape drive is on, but not flashing.
- 2 Verify that the tape drive's cartridge opening is empty. (In other words, if any other cartridge is in the tape drive, unload and eject it.)

- 3 Press and hold the Eject button for six seconds; after six seconds, the left (Drive Density) LED begins to flash.
- 4 Release the Eject button, then quickly press and release the Eject button again. At this point, the left (Drive Density) and middle (Drive Status) LEDs start flashing synchronously in a regular, rhythmic pattern. The tape drive is now in Firmware Upgrade mode.

You now have a “window” of one minute to insert the CUP/FUP data cartridge. If you do *not* insert a CUP/FUP data cartridge and the one minute time window expires, both LEDs stop flashing, although the middle (Drive Status) LED remains on (steadily illuminated). The tape drive is now out of Firmware Upgrade mode and can be used in a normal manner (once you insert a data cartridge). To put the tape drive back in Firmware Upgrade mode, repeat the previous steps 2, 3, and 4.

- 5 Insert the CUP/FUP data cartridge.
- 6 After you insert the CUP/FUP data cartridge, the left (Drive Density) and middle (Drive Status) LEDs change their pattern and start flashing in an alternating pattern. The tape drive is now performing the firmware upgrade.

<p>Note: The firmware upgrade fails the microcode update process if the firmware personalities do not match; the history log records this information, as well as the reason for the failure.</p>
--

- 7 Wait several minutes for the update process to complete. The left (Drive Density) and middle (Drive Status) LEDs flash the entire time that memory is being updated.
- 8 When the update is complete, the tape drive resets itself and goes through POST. The tape drive rewinds the CUP/FUP data cartridge, unloads it, and ejects it. SCSI status indicates that microcode has been updated (06h, 3F, 01).

<p>Note: If the tape drive is mounted in a tape automation library, the CUP/FUP data cartridge rewinds to BOT and unbuckles in preparation for unloading, but does not automatically eject.</p>
--

Firmware (Code) Update Troubleshooting

Try these remedial actions if the tape drive's code update fails:

- Updating the same revision

If you request a code update that is the same as the code revision already on the tape drive, the system updates the controller code but not the servo-specific code. The steps for this type of update are the same as for a normal update.

- Updating fails, which causes the tape drive to be reset; the problem can result from any of the following circumstances:
 - Data cartridge contains incompatible update image.
 - Data cartridge does not contain an update image.
 - No data cartridge in the tape drive.

Cleaning the Tape Mechanism

This section discusses the SDLT 600 tape drive cleaning tape, maintenance considerations, and important compatibility issues you need to be aware of.

Note: When your backup software indicates needed cleaning, or the yellow LED on the tape drive comes on, use the SDLT CleaningTape to clean the unit. Do not clean the tape drive unless the tape drive specifically indicates cleaning is necessary.

Occasional Cleaning of Tape Head

SDLT 600 tape drives occasionally require preventive cleaning. The amount of ambient pollution and particulates in the environment, to a large degree, dictates the cleaning frequency.

Clean your tape drive only when cleaning is necessary. Your backup software or the yellow alert LED located on the front bezel of the tape drive notify you if you need to clean the tape drive; the location of this LED (and other front bezel LEDs) is shown in [figure 20](#).

Clean the SDLT 600 tape drive with the SDLT CleaningTape, which is also used to clean the SDLT 220 and SDLT 320 tape drives.

Caution: Use ONLY the SDLT CleaningTape. Other cleaning tapes, such as CleaningTape III or DLT VS CleaningTape, are incompatible with the SDLT 600 tape drive heads.

When to Use the Cleaning Tape

The SDLT 600 tape drive uses a built-in tape cleaning algorithm in conjunction with a *cleaning tape*. The SDLT CleaningTape is packaged in a plastic case, and is light gray in color.

A yellow LED located on the front bezel of the SDLT 600 tape drive indicates when cleaning is needed; [figure 20](#) shows the location of this LED (and other front bezel LEDs).

Life Expectancy of the Cleaning Tape

Each SDLT CleaningTape is good for 20 uses. Use one of the labels that is supplied with the tape to track the number of uses.

Compatibility of the Cleaning Tape

The SDLT CleaningTape is intended for use in SDLT 600 tape drives, autoloaders, and libraries only. Alternatively stated, the SDLT CleaningTape only cleans the SDLT MRC heads.

Loading the Cleaning Tape Into a Tabletop Tape Drive

Follow these steps to load an SDLT CleaningTape into an SDLT 600 tabletop tape drive:

Note: To use the cleaning tape in an Autoloader or Library tape drive, refer to your owner's manual.

- 1 Insert the cleaning tape, with the Front Slide Label Slot facing outward, into the tape drive until the tape drive engages with the cleaning tape and begins to take up the cleaning media. The green Drive Status LED flashes and the cleaning cycle begins automatically.

- 2 When the cleaning cycle completes, the cleaning tape automatically ejects from the tape drive and the yellow alert LED turns off.

Note: On the last cleaning, the cleaning tape will not eject. Use the Eject button on the front of the tape drive to eject the expired cleaning tape and dispose of the cleaning tape.

- 3 Remove the cleaning tape, place it back into its plastic case, and mark the label after each cleaning.

Front Panel Controls and LEDs

All controls and LEDs are on the tape drive's front panel. See [figure 20](#) for details. Use these controls and LEDs to operate the tape drive and monitor the SDLT 600 tape drive system's activities. [Table 32](#) and [table 33](#) on page 79 describe Control and LED functionality.

Figure 20 SDLT 600 Tape Drive Front Panel

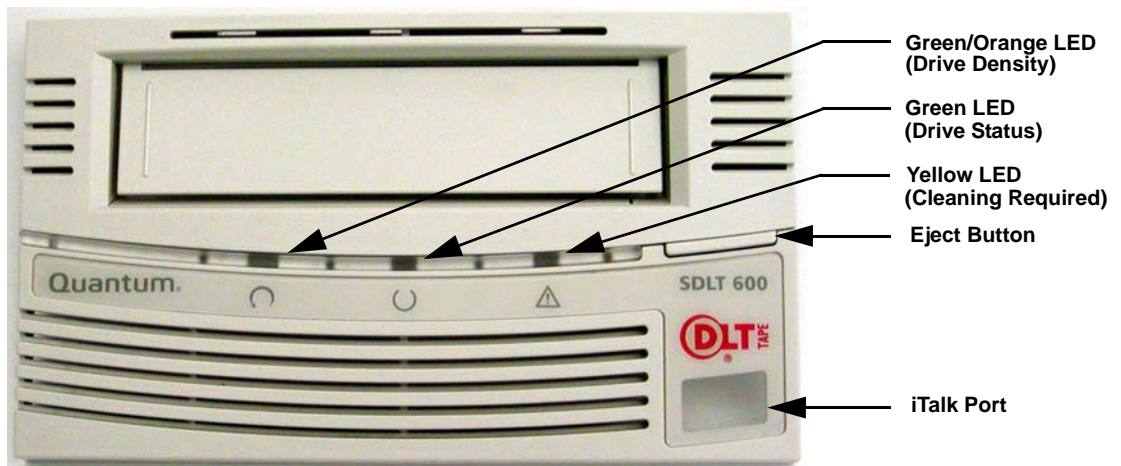



On the SDLT 600 tape drive, the leftmost LED is dual color (green/orange). This LED is the Density Indicator. When you insert a Super DLTtape II data cartridge, this LED illuminates green. When the tape drive detects a backward read compatible (BRC) data cartridge, this LED illuminates orange. (The SDLT 600 tape drive backward reads Super DLTtape I data cartridges formatted in an SDLT 220 or SDLT 320 tape drive, or DLTtape VS1 data cartridges formatted in a VS160 tape drive.)

If a DLTtape IV data cartridge is inserted, the Drive Density LED is off. [Table 32](#) summarizes these combinations.

Table 32 Dual-Color Drive
Density LED Appearance for
Type of Data Cartridge Loaded

Possible Data Cartridge Scenario	LED Color/State
No data cartridge is inserted	Off
SDLT 600 tape drive formatted Super DLTtape II data cartridge inserted	Green/On
Blank Super DLTtape II data cartridge inserted	Green/On
Super DLTtape II data cartridge ejected	Green/Remains On
SDLT 220 tape drive formatted Super DLTtape I data cartridge inserted	Orange/On
SDLT 320 tape drive formatted Super DLTtape I data cartridge inserted	Orange/On
Blank Super DLTtape I data cartridge inserted	Orange/On
Any Super DLTtape I data cartridge ejected	Off
DLT VS160 tape drive formatted DLTtape VS1 data cartridge inserted	Orange/On
Blank DLTtape VS1 data cartridge inserted	Orange/On
DLTtape VS1 data cartridge ejected	Off
Any DLTtape IV data cartridge inserted	Off
SDLT 600 tape drive reset	All LEDs illuminate briefly and then illuminate in sequence until the reset completes

Table 33 How to Interpret the Front Panel LEDs and Other Controls

LED/Button/ Port Title	Color/ Symbol	Action	Explanation
Drive Density LED	Orange/ Green 	On/Off	See table 32 .
Drive Status LED	Green 	Flashing	The tape drive is in use. This includes functions such as: <ul style="list-style-type: none"> • The tape is moving. • The tape drive is calibrating, reading, writing, or rewinding the tape. • The tape drive is loading, unloading, or rewinding.
		On	The tape drive is idle. There may or may not be a data cartridge in the tape drive.
		Off	The tape drive has not been powered on or is not plugged into a power source.
Cleaning Required LED	Yellow 	On	Cleaning is required. See Cleaning the Tape Mechanism on page 75 for cleaning information.
		Off	Cleaning is not required.
Eject Button		Press	Use the Eject button to eject the tape data cartridge from the tape drive. When you press the button, the tape drive completes any active writing of data to the tape, then ejects the data cartridge. Refer to the applicable data cartridge appendix for detailed data cartridge handling procedures.

LED/Button/ Port Title	Color/ Symbol	Action	Explanation
Infrared Communication Port			This infrared port, also known as iTalk, provides a wireless remote testing base for customers and integrators to access system diagnostic information. See your Quantum sales representative for more information.

Note: Whenever the tape drive resets, all LEDs illuminate briefly and then illuminate in sequence until the reset completes. Whenever the tape drive encounters an error, all LEDs flash together.

Troubleshooting

The following subsections provide troubleshooting information that might be helpful should the system fail its Power-On Self-Test (POST).

See the data cartridge appendices in this manual ([appendix A, Super DLTtape I and Super DLTtape II Data Cartridges](#) and [appendix B, DLTtape VS1 Data Cartridge](#)) for complete visual inspection instructions for Super DLTtape I & II, and DLTtape VS1 data cartridges.

The web site <http://www.dlftape.com> also includes valuable information about SDLT systems.

POST Troubleshooting

[Table 34](#) provides troubleshooting tips that you will find useful in the event that your SDLT 600 tape drive system fails its POST.

If, after attempting the recommended actions listed in the table, the problem still exists or recurs, a hardware failure may be the cause. Contact your service representative.

Table 34 Troubleshooting
Chart

If...	Then...	You should...
System does not recognize the SDLT 600 tape drive system.	System may not be configured to recognize the interface ID.	Configure system to recognize the SDLT 600 tape drive system's ID.
	Interface ID may not be unique.	Change the interface ID and reconfigure the system. The new ID becomes effective at the next power on or interface bus reset.
	Interface adapter parameters may not be correct.	Check interface adapter documentation.
	Interface signal cable may be loose.	Ensure interface cable is fully seated at each connector end.
	Interface terminator may be loose or not present on the bus.	Ensure correct, secure termination of bus.
	Interface bus may not be terminated correctly.	<p>If the SDLT 600 tape drive system is last or only device on bus (except for adapter), be certain the terminator is installed on the SDLT 600 tape drive system.</p> <p>If the SDLT 600 tape drive system is not the last or only device on the bus, check the cable connections and ensure that the bus is properly terminated at each end.</p>
	Interface terminator may not be at end of bus or more than two terminators may be present.	Ensure that a terminator is installed at each end of the bus. One terminator is usually installed at the host end of the bus.
	Interface bus may be too long.	Limit bus length to ANSI interface standard for the interface being used.

If...	Then...	You should...
System does not recognize the SDLT 600 tape drive system. (continued)	Too many devices on the bus.	Limit the number of devices on the bus (including the interface adapter) to match the limits of the interface being used.
	A device may not have been turned on and a valid interface ID may not have been configured before the system powering on and loading BIOS.	Turn the tape drive power on first, and then turn on power to the system. Do this so that the tape drive is properly recognized by the system.
The tape drive does not power on.	No power is reaching the tape drive.	Check the tape drive's power cable connection at the back of the system.
Nonfatal or fatal errors have occurred for which the cause cannot be determined.	Interface bus termination or the interface bus cable connections may be incorrect. The AC power source grounding may be incorrect (tabletop version).	Ensure the SCSI bus is terminated and that all connections are secure. Use an AC outlet for the tabletop tape unit on the same AC line used by the host system.

Over Temperature Condition

The SDLT 600 tape drive has a thermal sensor located in the tape path. This sensor, which is used to accurately monitor the air temperature in the tape path, issues a TapeAlert warning at 47 °C, and detects an overtemp condition when the temperature in the tape path reaches 50 degrees C. When the tape path temperature sensor detects an overtemp condition, the tape rewinds, unloads, and ejects from the tape drive. (As long as the tape drive is not mounted in a tape automation library, the tape ejects.) SCSI status indicates the tape drive is in the over temperature condition.

If the tape drive is mounted in a tape automation library, the data cartridge rewinds to BOT and unbuckles in preparation for unloading, but does not automatically eject. For more information, see the *SDLT 600 Design and Integration Guide (81-81196-xx)*.

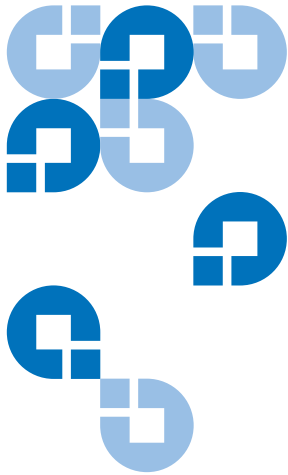

Regulatory Compliance

This chapter describes various regulations that apply to the SDLT 600 tape drive:

- [Safety Regulations](#)
- [Electromagnetic Field Specifications](#)
- [Acoustic Noise Emissions](#)
- [Class A Statements \(Internal Tape Drive\)](#)
- [Class B Statements \(Tabletop Tape Drive\)](#)
- [Environmental Compliance](#)
- [Disposal of Electrical and Electronic Equipment](#)

Safety Regulations

This section lists the safety regulations that the SDLT 600 tape drive meets or exceeds.

Safety Certifications

The SDLT 600 tape drive meets or exceeds the following safety requirements:

- UL 60950: Information Technology Including Electrical Business Equipment (USA)
- EN60950/IEC 950: Information Technology Including Electrical Business Equipment (Europe)
 - EN60825-1 Information Technology Equipment

The SDLT 600 tape drive is also certified to bear the GS mark.

The SDLT 600 tape drive is a Class I laser product that complies with 21 CFR 1040.10 as applicable on the date of manufacture.

Electromagnetic Field Specifications

SDLT 600 tape drives are electrical devices; as such, this equipment generates, uses, and may emit radio frequency energy. The tape drives may emit energy in other frequencies, as well, as discussed in the following subsections.

Electromagnetic Emissions

The internal version of the SDLT 600 tape drive system complies with FCC Class A in a standard enclosure; the tabletop version complies with FCC Class B limits.

Electromagnetic Interference Susceptibility

[Table 35](#) provides regulations and certifications held by the SDLT 600 tape drive for Electromagnetic Interference (EMI).

Table 35 EMI Regulations and Certifications

Type	Regulation/Certification
EEC Directive 89/336 CE	EN55022 (EU) EN55024 (EU)
CFR 47, 1995	FCC Rules Part 15B Class B
IECS-003	Canada
V-3/97.04	VCCI Class B (Japan)

Type	Regulation/Certification
CNS 13438	BSMI Class A (Taiwan)
AS/NZS 3548	Australia/New Zealand

Immunity and ESD Limits

[Table 36](#) lists the immunity and ESD failure level limits to which the SDLT 600 tape drive has been tested.

Test Name	Test Specification	Required Performance
-----------	--------------------	----------------------

EN55022: 1998 Radiated and Conducted Emissions

Radiated Electromagnetic Emissions	EN55022: 1998	Class B
Conducted Electromagnetic Emissions		

Current Harmonics and Flicker Emissions Tests

AC Power Supply Harmonic Emissions	EN61000-3-2	As per the standard
AC Power Supply Voltage Flicker	EN61000-3-3	As per the standard

EN55024: 1998 Immunity Tests

Electrostatic Discharge Immunity	EN61000-4-2	Criteria A
Radiated Electromagnetic Immunity	EN61000-4-3	Criteria A
Electrical Fast Transient / Burst Immunity	EN61000-4-4	Criteria B
Electrical Surge Immunity	EN61000-4-5	Criteria B
Conducted Electromagnetic Immunity	EN61000-4-6	Criteria A
Power Frequency Magnetic Field Immunity	EN61000-4-8	Criteria A

Test Name	Test Specification	Required Performance
AC Voltage Dips and Interrupts Immunity	EN61000-4-11	Criteria B

Acoustic Noise Emissions

[Table 36](#) lists acoustic noise emission levels, both as noise power and sound pressure, for the SDLT 600 tape drive. The table provides the preliminary declared values per ISO 9296 and ISO 7779/EN27779.

Table 36 Acoustic Noise Emissions, Nominal

Mode	Noise Power Emission Level (LNPEc)		Sound Pressure Level (LPAc)*	
	Internal	Tabletop	Internal	Tabletop
Idle	Not applicable	5.4 Bel	Not applicable	42 dB
Streaming	5.9 Bel	5.9 Bel	47 dB	53 dB

* Sound pressure level measured at front of tape drive.

Class A Statements (Internal Tape Drive)

FCC Statement

This equipment has been tested and found to comply with the limits for a Class A digital device, pursuant to Part 15 of the FCC Rules. These limits are designed to provide reasonable protection against harmful interference when the equipment is operated in a commercial environment. This equipment generates, uses, and can radiate radio frequency energy and, if not installed and used in accordance with the

instruction manual, may cause harmful interference to radio communications.

Any changes or modifications made to this equipment may void the user's authority to operate this equipment.

Operation of this equipment in a residential area may cause interference in which case the user at his own expense will be required to take whatever measures may be required to correct the interference.

This device complies with Part 15 of the FCC Rules. Operation is subject to the following conditions:

- 1 This device may not cause harmful interference, and
- 2 This device must accept any interference received, including interference that may cause undesired operation.

Note: Additional information on the need to interconnect the device with shielded (data) cables or the need for special devices, such as ferrite beads on cables, is required if such means of interference suppression was used in the qualification test for the device. This information will vary from device to device and needs to be obtained from the EMC (Electromagnetic Compatibility) group or product manager.

Canada (Digital Apparatus)

Reference: *Interference-Causing Equipment Standard*, ICES-003, Issue 2

This Class A digital apparatus complies with Canadian ICES-003.

Cet appareil numérique de la classe A est conforme à la norme NMB-003 du Canada.

CISPR-22 Warning!

This is a Class A product. In a domestic environment this product may cause radio interference in which case the user may be required to take adequate measures.

Achtung!

Dieses ist ein Gerät der Funkstörgrenzwertklasse A. In Wohnbereichen können bei Betrieb dieses Gerätes Rundfunkstörungen auftreten, in

welchen Fällen der Benutzer für entsprechende Gegenmaßnahmen verantwortlich ist.

Attention!

Ceci est un produit de Classe A. Dans un environnement domestique, ce produit risque de créer des interférences radioélectriques, il appartiendra alors à l'utilisateur de prendre les mesures spécifiques appropriées.

Taiwan (BSMI) Statement

警告使用者:

這是甲類的資訊產品，在居住的環境中使用時，可能會造成射頻干擾，在這種情況下，使用者會被要求採取某些適當的對策。

Japan (VCCI) Statement

この装置は、クラスA情報技術装置です。この装置を家庭環境で使用すると電波妨害を引き起こすことがあります。この場合には使用者が適切な対策を講ずるよう要求されることがあります。

VCCI- A

DEN-AN Notice (Japan)

すべての電源コードが同じ定格電流を使用するとは限りません。同封されている電源コードを他の製品と一緒に使用しないでください。また、家庭用の延長コードをQuantum製品と一緒に使用しないでください。複数の電源コードを必要とする製品の電源を完全に切るには、システムに接続しているすべての電源コードを外してください。

Class B Statements (Tabletop Tape Drive)

FCC Statement

This equipment has been tested and found to comply with the limits for a Class B digital device, pursuant to Part 15 of the FCC Rules. These limits are designed to provide reasonable protection against harmful interference when the equipment is operated in a residential environment.

This equipment generates, uses, and can radiate radio frequency energy and, if not installed and used in accordance with the instruction manual, may cause harmful interference to radio communications. However, there is no guarantee that interference will not occur in a particular installation. If this equipment does cause harmful interference to radio or television reception, which can be determined by turning the equipment off and on, the user is encouraged to try to correct the interference by one or more of the following measures:

- Reorient or relocate the receiving antenna.
- Increase the separation between the equipment and receiver.
- Connect the equipment into an outlet on a circuit different from that to which the receiver is connected.
- Consult the dealer or an experienced radio or TV technician for help.

Any changes or modifications made to this equipment may void the user's authority to operate this equipment.

Operation of this equipment in a residential area may cause interference in which case the user at his own expense will be required to take whatever measures may be required to correct the interference.

Note: Additional information on the need to interconnect the device with shielded (data) cables or the need for special devices, such as ferrite beads on cables, is required if such means of interference suppression was used in the qualification test for the device. This information will vary from device to device and needs to be obtained from the EMC (Electromagnetic Compatibility) group or product manager.

Canada (Digital Apparatus)

Reference: *Interference-Causing Equipment Standard, ICES-003, Issue 2*

This Class B digital apparatus complies with Canadian ICES-003.

Cet appareil numérique de la classe B est conforme à la norme NMB-003 du Canada.

Taiwan (BSMI) Statement

警告使用者:

這是甲類的資訊產品，在居住的環境中使用時，可能會造成射頻干擾，在這種情況下，使用者會被要求採取某些適當的對策。

Japan (VCCI) Statement



Environmental Compliance

Quantum is committed to providing quality products in an environmentally sound manner and to comply with all applicable environmental laws, rules and regulations.

This product was designed, manufactured and made available with consideration to worldwide laws, rules and regulations applicable to the product and the electronics industry including the European Union Directives 2002/95/EC & 2002/96/EC (RoHS and WEEE).

For further information on Quantum's Environmental Compliance and Global Citizenship, please consult the following Web site at <http://qcare.quantum.com>.

Disposal of Electrical and Electronic Equipment

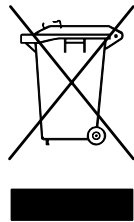

This symbol on the product or on its packaging indicates that this product should not be disposed of with your other waste. Instead, it should be handed over to a designated collection point for the recycling of electrical and electronic equipment. The separate collection and recycling of your waste equipment at the time of disposal will help to conserve natural resources and ensure that it is recycled in a manner that protects human health and the environment. For more information about where you can drop off your waste equipment for recycling, please visit the Quantum Web site at <http://qcare.quantum.com> or contact your local government authority, your household waste disposal service or the business from which you purchased the product.

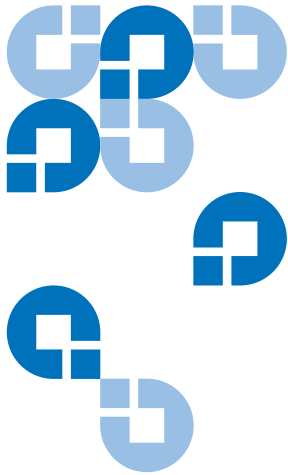

Appendix A

Super DLTtape I and Super DLTtape II Data Cartridges

This appendix discusses Super DLTtape I and Super DLTtape II data cartridge information. Information in this appendix includes the following topics:

- [Recognizing Quantum Super DLTtape I and II Data Cartridges](#)
- [Data Cartridge Handling Guidelines](#)
- [Data Cartridge Inspection Procedure](#)
- [Data Cartridge Write-protect Switch](#)
- [Loading a Data Cartridge](#)
- [Unloading a Data Cartridge.](#)

[Appendix B](#) for DLTtape VS1 data cartridge information.

Recognizing Quantum Super DLTtape I and II Data Cartridges

The Super DLTtape I data cartridge is dark green. The Super DLTtape II data cartridge is dark blue. Both data cartridges have a keying feature that prevent insertion into the older generation DLT tape drives.

Note: You cannot insert the Super DLTtape II data cartridge into an SDLT 220 or SDLT 320 tape drive; or any other earlier model Quantum tape drive.

Other than color differences, the basic geometry, write protection switch, and label space for the Super DLTtape I and Super DLTtape II, the data cartridges are basically the same. This simplifies the integration of the SDLT 600 tape drive into existing operating environments and into automated tape libraries.

The SDLT 600 tape drive is backward read compatible with Super DLTtape I data cartridges formatted in the SDLT 220 or SDLT 320 tape drive. [Figure 21](#) shows outside characteristic differences of the Super DLTtape I and Super DLTtape II data cartridges.

Figure 21 Super DLTtape Data Cartridges Read by SDLT 600 Tape Drive

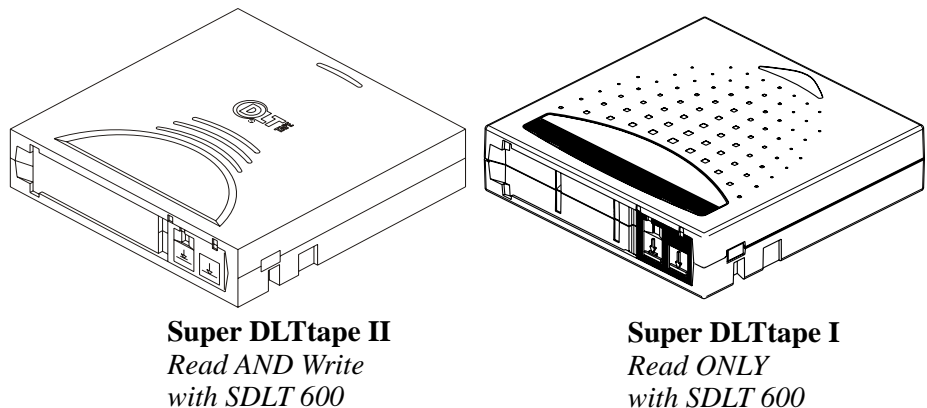

Note: The Super DLTtape I and Super DLTtape II data cartridges have a keying feature to ensure you cannot load them into a previous generation DLT tape drives.

Data Cartridge Handling Guidelines

By following general handling procedures, conducting careful visual inspections of data cartridges on a regular, ongoing basis, and being certain to store data cartridges within their environmental limits, you will greatly reduce any chance that you will experience problems with your data cartridges or cause damage to your Super DLTtape system. **Respect your media as much as you do your data.**

Ensure that your data cartridge backup solution performs reliably by following these general handling guidelines:

- Always keep each data cartridge in its protective plastic case when it is not in the tape drive.
- When carrying data cartridges in their cases, always orient the cases so that the grooves in the cases interlock. This prevents the cases from slipping apart and falling.
- Never stack the data cartridges in a stack of more than five.
- When placing data cartridges in archival storage, be certain you stand each data cartridge vertically.
- Do not carry data cartridges loosely in a box or any other container. Allowing data cartridges to jostle together exposes them to unnecessary physical shock.
- Always observe the proper environmental conditions for storing data cartridges. See the data cartridge reference card supplied with each data cartridge. The ambient operating environment for the data cartridge is

Temperature	10 °C to 40 °C (50 °F to 104 °F)
Relative Humidity	20% to 80% (non-condensing)

Note: If storage or transportation of a data cartridge has exposed it to conditions outside the ambient values shown above, you should **condition** the data cartridge to its operating environment for a 24-hour period.

- Maintain clean and smoke-free operating and storage environments.
- Never expose the data cartridge to moisture or direct sunlight.
- Do not place data cartridges on or near devices that may produce magnetic fields, such as computer monitors, motors, or video equipment. Such exposure can alter or erase data on the media.
- Avoid unnecessary opening of the data cartridge door; this may expose the media to contamination or physical damage.
- Do not touch or allow direct contact with the media or tape leader. Dust or natural skin oils can contaminate the data cartridge and impact media performance.
- A dropped data cartridge may have dislodged, loosened, or damaged internal components. If you drop a data cartridge, give it a thorough visual inspection, as described in “Data Cartridge Inspection Procedure” on page 96.
- Never apply adhesive labels or “sticky” notes on the top, side, or bottom of your Super DLTtape I or Super DLTtape II data cartridge. Only use the slide-in type label provided with each data cartridge and slide it into the label slot on the data cartridge.
- Do not use graphite pencils, water-soluble felt pens, or other debris-producing writing instruments on your labels. Never erase a label – replace it.
- Be certain you place the unused data cartridge labels in the protective box so that you do not inadvertently pick them up along with the data cartridge during subsequent usage. A static electricity charge on a data cartridge may cause a label to cling to the data cartridge. A label that is accidentally inserted into the tape drive along with a data cartridge can prevent the hub reel and drive gear from meshing.
- Follow all data cartridge handling instructions that accompany your data cartridges or tape drive.

Data Cartridge Inspection Procedure

Ensure your data cartridge backup solution performs reliably by following the Visual Mechanical Inspection (VMI) procedures described in this subsection. These steps will help you identify any potential data cartridge problems, and will prevent accidental loss of data or damage to your SDLT 600 tape drive system.

You should do an inspection if any of these conditions occur:

- As a general practice whenever you change or load a new data cartridge.
- If a data cartridge is dropped or subjected to some hard physical shock.
- If the SDLT 600 tape drive becomes inoperable after loading a data cartridge.
- If you receive a shipment of data cartridges that show any sign of shipping damage.

Follow these steps to visually inspect an Super DLTtape I or Super DLTtape II data cartridge:

- 1** Remove the data cartridge from its protective plastic case.
- 2** Check for loose debris attached to the shell, and for other contamination (oily, slimy, or sticky substances) that may have built up on the surface of the shell.
- 3** Check the data cartridge for any obvious cracks or other physical damage to the shell. Rotate the data cartridge in your hands, looking for broken or missing parts.
- 4** Grasp the data cartridge to view the bottom as shown in [figure 22](#). (The media access door is on the top edge and the write protect switches are on the bottom edge.)

Figure 22 Bottom View of Super DLTtape II Data Cartridge

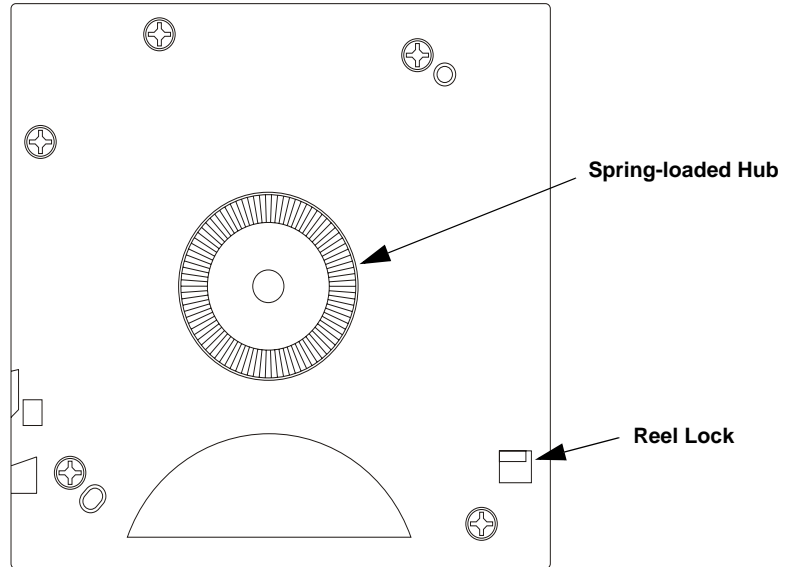

- 5 See [figure 23](#) and check the reel lock openings to ensure the small plastic tabs inside are partially visible. The reel locks are black. The reel locks can break if you drop the data cartridge. *If the reel lock tabs are not visible, do not use the data cartridge.*

Figure 23 Super DLTtape II Data Cartridge Reel Locks

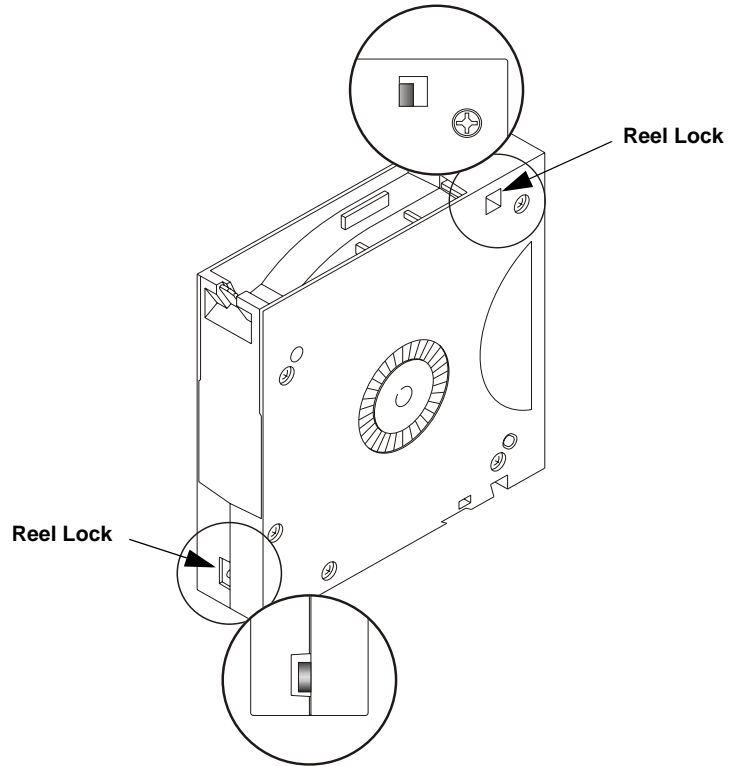

- 6 Once again, look at the end of the data cartridge, holding it as shown in [figure 24](#).

Figure 24 Opening the Super DLTtape II Data Cartridge Door

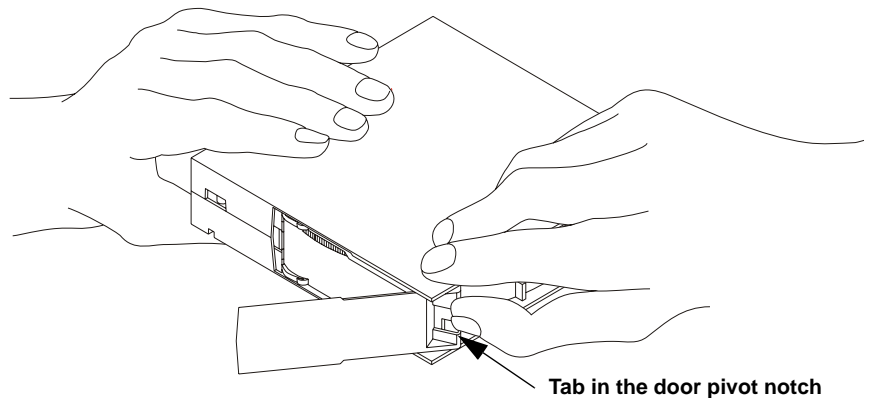

- 7 Open the data cartridge door by pressing on the tab in the door pivot notch as shown in [figure 24](#). Use care that you do not touch the tape leader.
- 8 Compare what you see inside the data cartridge door to [figure 25](#). Look for damage to the data cartridge clips, including:
 - Bent or towed-in appearance on one or both clips
 - Improper seating (clips should be fully retracted towards the left side of the opening)
 - Bending of the leader bar that supports the clips.

Figure 25 Problems to Look for Inside the Data Cartridge Door

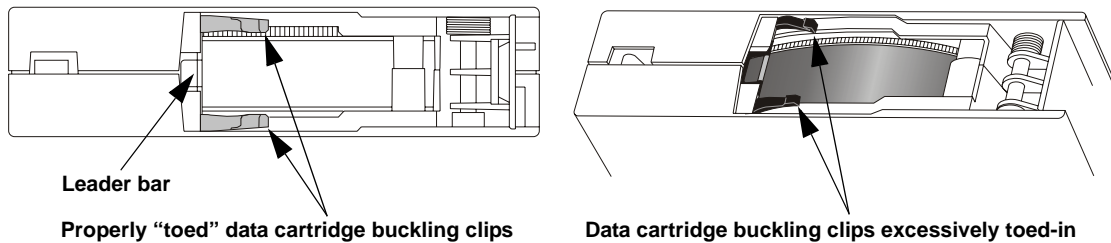

- 9 Examine the visible tape leader for excessive debris, oily or sticky residue, condensed droplets of moisture, or any other signs of contamination.
- 10 Finally, check for proper operation of the data cartridge's write-protect switch (see [figure 26](#)). This sliding switch, located on the end of the data cartridge used for the label, should snap smartly back and forth, and the orange tab should be visible when the data cartridge is set to provide write protection (you cannot write over the data already on the media).

Data Cartridge Write-protect Switch

Each data cartridge has a write-protect switch that you can use to prevent accidental erasure of data. Before inserting the data cartridge into the tape

drive, position the write-protect switch on the front of the data cartridge ([figure 26](#)) according to the type of operations you expect to perform.

Figure 26 Write-Protect Switch on Super DLTtape II Data Cartridge

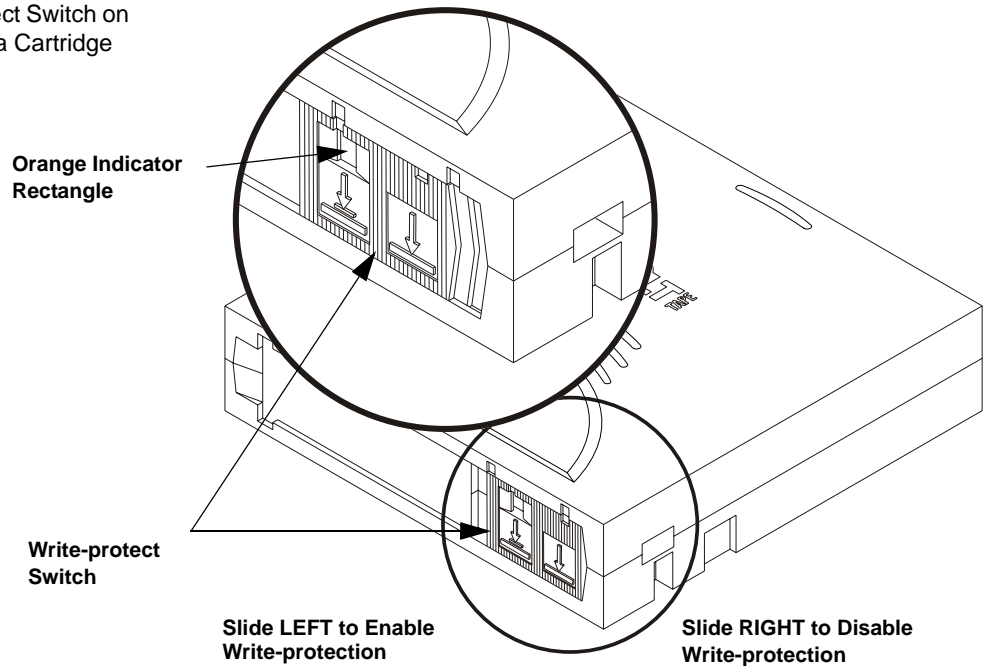

- Slide the write-protect switch to the left to **enable** write protection (you can read existing data; however, you cannot write over existing data on the media, nor append additional data to the media). When you move the write-protect switch to the left, a small orange rectangle is visible. This is your visual reminder that you cannot write data to the media.
- Slide the write-protect switch to the right to **disable** write protection (you can write over existing data on the media, and you can append additional data to the media unless the data cartridge is write-protected via firmware). When write-protection is disabled, no orange rectangle is visible.

For more details, see [table 37](#).

Table 37 Write-Protect Switch Positions

Write-protect Switch Position	Orange Write-protect Indicator	Result
Before Loading the Data Cartridge		
Enabled (Slide switch to left)	Visible	You cannot write data to the media. You cannot overwrite existing data on the media. You cannot append additional data to the media.
Disabled (Slide switch to right)	Not Visible	Unless the data cartridge is write-protected via firmware: <ul style="list-style-type: none"> - You can write data to the media. - You can overwrite existing data on the media. - You can append additional data to the media.
After Loading the Data Cartridge and During Operation		
If you move the write-protect switch from its right (disabled) position to its left (enabled) position	Visible	If the tape drive is currently writing to a data cartridge, the write-protect feature does not take effect until <i>after</i> the current write operation completes.
If you move the write-protect switch from its left (enabled) position to its right (disabled) position	Not Visible	The data cartridge becomes write-enabled <i>after</i> a variable amount of seconds.

Loading a Data Cartridge

Complete this subsection to load a data cartridge into the front of the tape drive; see [figure 27](#) as needed.

- 1 Insert the data cartridge into the front of the tape drive, as shown in [figure 27](#).
- 2 Push the data cartridge fully into the tape drive.

The Drive Status LED flashes to show that the media is loading. When the media reaches the Beginning of Tape (BOT) marker, the LED lights steadily. The data cartridge is now ready for use.

Figure 27 Loading a Super DLTtape II Data Cartridge

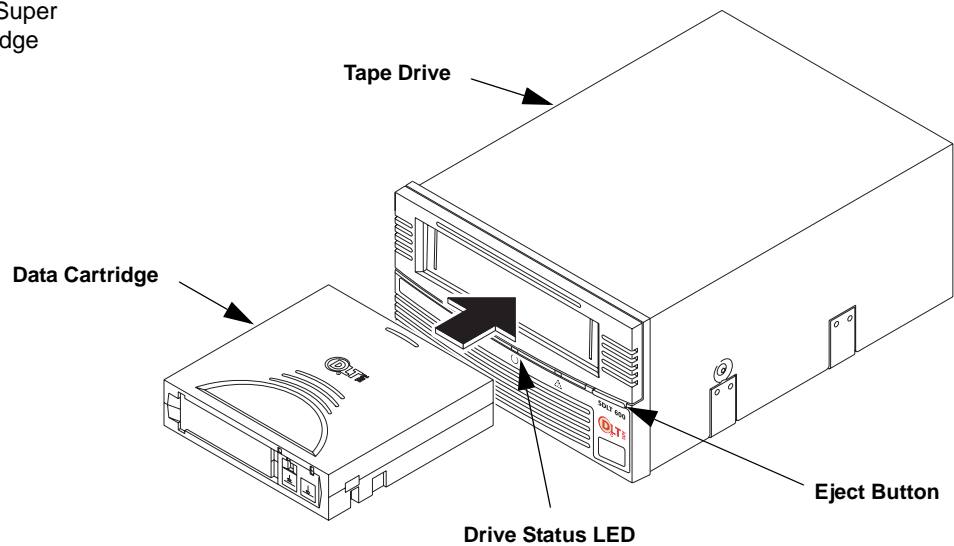

Unloading a Data Cartridge

Follow these steps to unload a data cartridge; see [figure 27](#) as needed.

Caution: Remove the data cartridge from the tape drive BEFORE turning off host power. Failure to remove a data cartridge may result in data cartridge or tape drive damage.

Do NOT rush removal of the data cartridge. Wait until the tape drive ejects the data cartridge and the Drive Status LED lights steady before removing the data cartridge.

- 1 Press the **Eject** button (or issue an appropriate system software command); the tape drive completes any active writing of data to the media, then rewinds. The Drive Status LED flashes as the media rewinds.

When the media is finished rewinding, the tape drive ejects the data cartridge and the Drive Status LED lights steadily.

- 2 Remove the data cartridge from the tape drive and return the data cartridge to its plastic case to protect it from damage.



Appendix B DLTtape VS1 Data Cartridge

The SDLT 600 tape drive is backward read compatible with DLTtape VS1 data cartridges formatted in the DLT VS 160 tape drive. Data backed up using a DLTtape VS1 data cartridge in a DLT VS160 tape drive is retrievable using the SDLT 600 tape drive.

By following general handling procedures, conducting careful visual inspections of data cartridges on a regular, ongoing basis, and being certain that you store data cartridges within their environmental limits, you will greatly reduce any chance that you will experience problems with your data cartridges or cause damage to your SDLT system. **Respect your media as much as you do your data.**

This appendix discusses the DLTtape VS1 data cartridge; for Super DLTtape I and Super DLTtape II data cartridge information, see [appendix A](#).

Information in this appendix includes the following topics:

- [Data Cartridge Handling Guidelines](#)
- [Data Cartridge Inspection Procedure](#)
- [Data Cartridge Write-Protect Switch](#)
- [Loading a Data Cartridge](#)
- [Unloading a Data Cartridge](#).

Data Cartridge Handling Guidelines

Ensure your data cartridge backup solution performs reliably by following these general handling guidelines:

- Always keep each data cartridge in its protective plastic case when it is not in the tape drive.
- When carrying data cartridges in their cases, always orient the cases so that the grooves in the cases interlock. This prevents the cases from slipping apart and falling.
- Never stack the data cartridges in a stack of more than five.
- When placing data cartridges in archival storage, be certain you stand each data cartridge vertically.
- Do not carry data cartridges loosely in a box or any other container. Allowing data cartridges to hit together exposes them to unnecessary physical shock.
- Always observe the proper environmental conditions for storing data cartridges. Refer to the data cartridge reference card supplied with each data cartridge. The ambient operating environment for the data cartridge is

Temperature	10 °C to 40 °C (50 °F to 104 °F)
Relative Humidity	20% to 80% (non-condensing)

Note: If storage or transportation of a data cartridge has exposed it to conditions outside the ambient values above, you should **condition** the data cartridge to its operating environment for a 24-hour period.

- Maintain clean operating, working, and storage environments.
- Do not expose the data cartridge to moisture or direct sunlight.
- Do not place data cartridges on or near devices that may produce magnetic fields, such as computer monitors, motors, or video equipment. Such exposure can alter or erase data on the media.
- Avoid unnecessary opening of the data cartridge door; this may expose the media to contamination or physical damage.

- Do not touch or allow direct contact with media or tape leader. Dust or natural skin oils can contaminate the data cartridge and impact media performance.
- Do not insert any data cartridge that has been dropped into the SDLT 600 tape drive without at least a thorough visual inspection, as described in [Data Cartridge Inspection Procedure](#) on page 106. A dropped data cartridge may have dislodged, loosened, or damaged internal components.
- Never apply adhesive labels or notes on the top, side, or bottom of your DLTtape VS1 data cartridge. Only use the user slide-in type label provided with each data cartridge and slide it into the label slot on the data cartridge.
- Do not use graphite pencils, water-soluble felt pens, or other debris-producing writing instruments on your labels. Never erase a label – replace it.
- Be certain you place the unused data cartridge labels in the protective box so that you do not inadvertently pick them up along with the data cartridge during subsequent usage. A static electricity charge on a data cartridge may cause a label to cling to the data cartridge. A label that is accidentally inserted into the tape drive along with a data cartridge can prevent the hub reel and drive gear from meshing.
- Follow all data cartridge handling instructions that accompany your data cartridges or tape drive.

Data Cartridge Inspection Procedure

Ensure your data cartridge backup solution performs reliably by following the Visual Mechanical Inspection (VMI) procedures described in this subsection. These steps help you identify any potential data cartridge problems, and prevent accidental loss of data or damage to your SDLT 600 tape drive system.

You should do an inspection if any of these conditions occur:

- As a general practice whenever you change or load a new data cartridge.

- If a data cartridge is dropped or subjected to some hard physical shock.
- If the SDLT 600 tape drive becomes inoperable after loading a data cartridge.
- If you receive a shipment of data cartridges that show any sign of shipping damage.

Follow these steps to visually inspect a DLTtape VS1 data cartridge:

- 1 Remove the data cartridge from its protective plastic case.
- 2 Gently shake the data cartridge. Listen for any rattling or sounds of any loose pieces inside the data cartridge. *If you hear anything loose inside, do not use the data cartridge.*
- 3 Check the data cartridge for any obvious cracks or other physical damage to the shell. Rotate the data cartridge in your hands, looking for broken or missing parts.
- 4 Grasp the data cartridge to view the bottom as shown in [figure 28](#). (The media access door is on the top edge and the write protect switches are on the bottom edge.)

Figure 28 Bottom View of DLTtape VS1 Data Cartridge

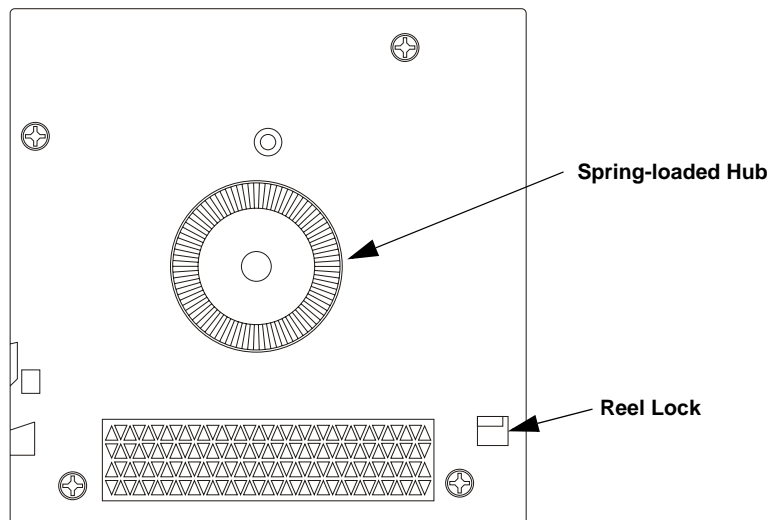

- 5 See [figure 29](#) and check the reel lock openings to ensure the small plastic tabs inside are partially visible. The reel locks are black. The reel locks can break if you drop the data cartridge. *If the reel lock tabs are not visible, do not use the data cartridge.*

Figure 29 DLtape VS1 Data Cartridge Reel Locks

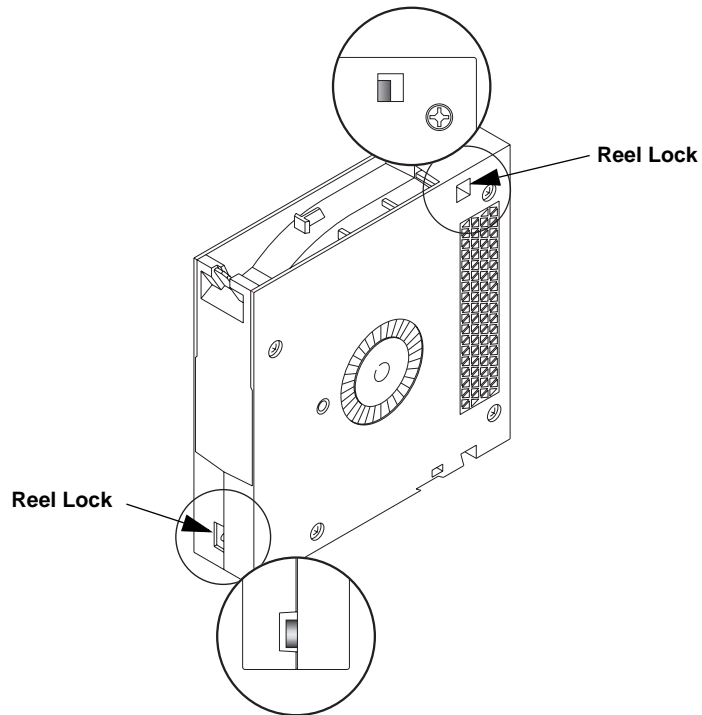

- 6 Look closely at the spring-loaded reel hub on the bottom of the data cartridge. Verify that the hub is centered within the circular opening in the data cartridge. Gently press the hub and be certain that it springs back into place—centered within its circular opening and completely flush with the plastic shell. [Figure 30](#) shows a defective spring-loaded reel hub. Do not use a data cartridge that fails this step.

Figure 30 Faulty Data Cartridge
Spring-loaded Reel Hub

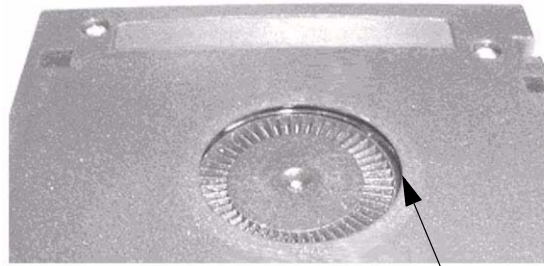

Data cartridge hub is recessed slightly, and when pressed, does not return to a position that is flush with the plastic shell

- 7 Once again, look at the end of the data cartridge, holding it as shown in [figure 31](#).

Figure 31 Opening the DLTape
VS1 Data Cartridge Door

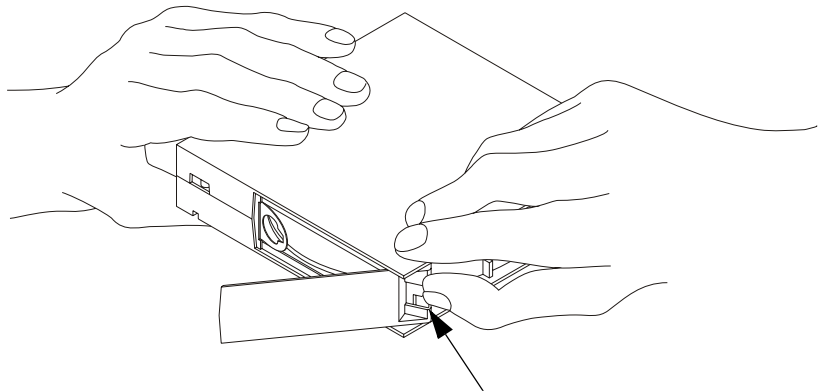

Tab in the door pivot notch

- 8 On the right side corner of the data cartridge is a small tab in a cut-out portion (the door pivot notch) of the data cartridge. Using your thumb, gently lift up on the tab and swing the door open as shown in [figure 31](#).
- 9 Look at the end of the data cartridge, holding it as shown in [figure 33](#). Use care that you do not touch the tape leader.

Figure 32 End View of DLTtape VS1 Data Cartridge (Tape Leader Loop in its Correct Position)

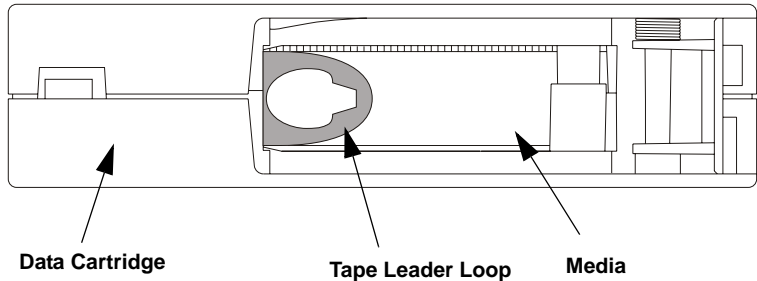

- 10** Inside the door, you will see the media and tape leader loop. The loop should stick up about an eighth of an inch when viewed from the edge; the loop must be a closed loop.
- 11** Examine the visible tape leader to ensure it is in the correct position as shown in [figure 32](#). *If the loop is torn, bent, pulled in, or not sticking up about an eighth of an inch, do not use the data cartridge.*
- 12** Examine the tape leader for any excessive debris, oily or sticky residue, condensed droplets of moisture, or any other signs of contamination.

Compare what you see inside the data cartridge door to illustrations in [figure 33](#). Look for faulty items including:

- A broken tape leader loop
- A swallowed tape leader loop
- Loose media inside the data cartridge.

Do not use a data cartridge that exhibit any of the type of problems shown in these examples.

Figure 33 DLTtape VS1 Data Cartridges with Visible Damage

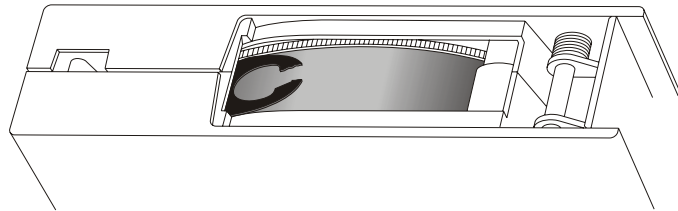

Broken tape leader loop

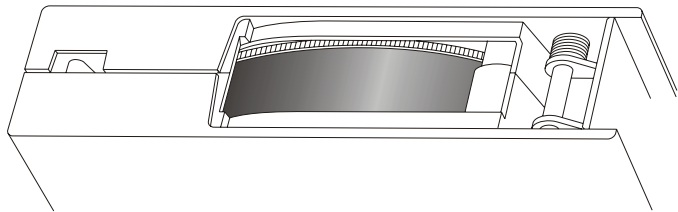

Swallowed tape leader loop

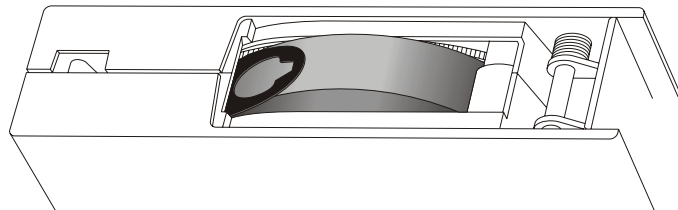

Loose media inside the data cartridge

- 13 Finally, check for proper operation of the data cartridge's write-protect switch (see [figure 35](#)). This sliding switch, located on the end of the data cartridge used for the label, should snap smartly back and forth, and the orange tab should be visible when the data cartridge is set to provide write protection (you cannot write over the data already on the media).

Data Cartridge Write-Protect Switch

Each data cartridge has a write-protect switch that you can use to prevent accidental erasure of data. Before inserting the data cartridge into the tape drive, position the write-protect switch on the front of the data cartridge (figure 34) according to the type of operations you expect to perform.

Since the DLTtape VS1 data cartridge is a read-only data cartridge when used in the SDLT 600 tape drive, the write-protect switch (in this configuration) does not apply.

Figure 34 Write-Protect Switch on DLTtape VS1 Data Cartridge

Slide LEFT to enable write-protection

Padlock "closed" indicating write-protection On

Write-protect Switch

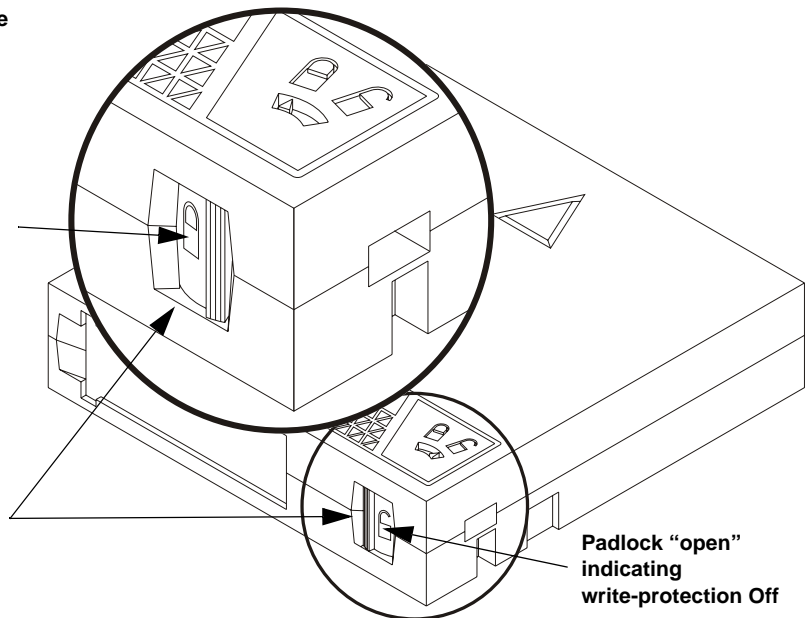

Padlock "open" indicating write-protection Off

Slide RIGHT to disable write-protection

- Slide the write-protect switch to the left to **enable** write protection (you can read existing data; however, you cannot write over existing data on the media, nor append additional data to the media). When

you move the write-protect switch to the left, a small **closed** padlock is visible. This is your visual reminder that you cannot write data to the media.

- Slide the write-protect switch to the right to **disable** write protection (you can write over existing data on the media, and you can append additional data to the media unless the data cartridge is write-protected via firmware). When write-protection is disabled, a small **open** padlock is visible.

Loading a Data Cartridge

Complete this subsection to load a data cartridge into the front of the tape drive; see [figure 35](#) as needed.

To load a data cartridge, follow these steps:

- 1 Insert the data cartridge into the front of the tape drive, as shown in [figure 35](#).
- 2 Push the data cartridge fully into the tape drive.

The Drive Status LED flashes to show that the media is loading. When the media reaches the Beginning of Tape (BOT) marker, the LED lights steadily. The data cartridge is now ready for use.

Figure 35 Loading a DLTape
VS1 Data Cartridge

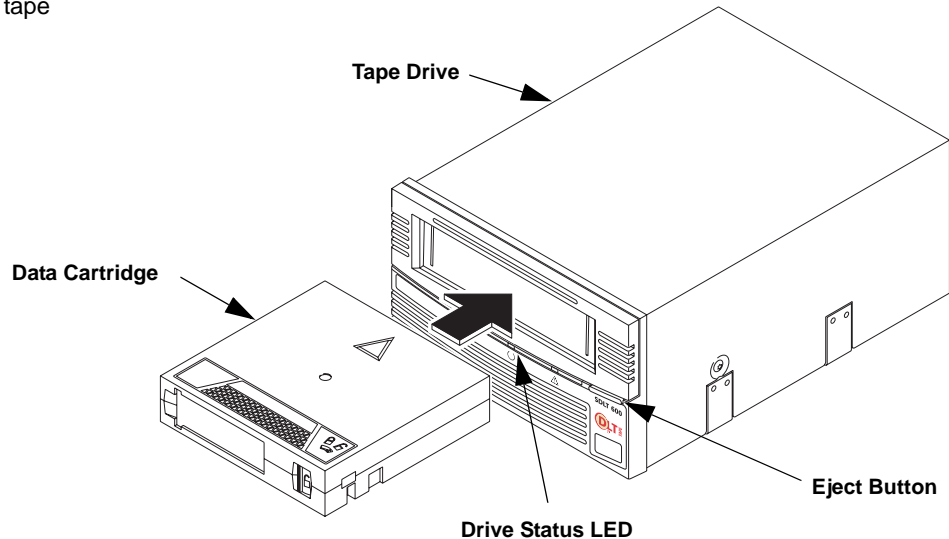

Unloading a Data Cartridge

Complete this subsection to unload a data cartridge; see [figure 35](#) as needed.

Caution: Remove the data cartridge from the tape drive BEFORE turning off host power. Failure to remove a data cartridge may result in data cartridge or tape drive damage.

Do NOT rush removal of the data cartridge: premature removal can cause tape leader failure. Wait until the tape drive ejects the data cartridge and the Drive Status LED lights steadily before removing the data cartridge.

- 1 Press the **Eject** button (or issue an appropriate system software command); the tape drive completes any active writing of data to the media. The Drive Status LED flashes as the media rewinds.
When the media is finished rewinding, the tape drive ejects the data cartridge and the Drive Status LED lights steadily.
- 2 Remove the data cartridge from the tape drive and return the data cartridge to its plastic case to protect the data cartridge from damage.

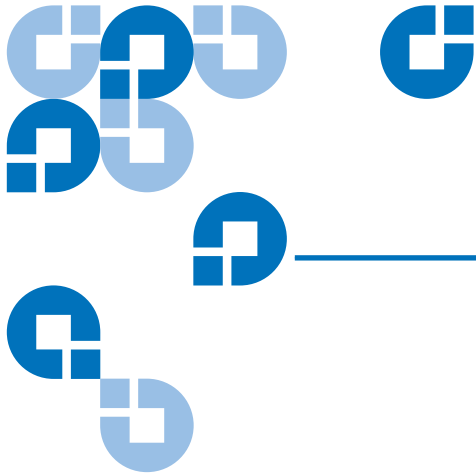

Glossary

The following is an alphabetical list of specialized words and technical terms with their definitions, commonly used in the tape drive and tape media industry.

A

Access (v.) To read, write, or update information on a storage medium, such as magnetic media. (n.) The operation of reading, writing, or updating stored information.

Access Time The interval between the time a request for data is made by the system and the time the data is available from the tape drive.

Advanced PRML Advanced Partial Response Maximum Likelihood. The advanced PRML channel technology provides high-encoding efficiency recording densities for greater capacity and performance.

Allocation The process of assigning particular areas of the media to particular data or instructions.

AMP Media Advanced Metal Powder Media. A state-of-the-art media first designed for Super DLTtape. It incorporates durable metal powder technology for high-density data storage and embedded non-magnetic information for head tracking.

Archiving The removal or copying of data from the computer system onto secondary storage media that is safely stored away.

ASIC Application Specific Integrated Circuit.

ASTM American Society for Testing and Materials.

B

Backup A copy of a file, directory, or volume on a separate storage device from the original, for the purpose of retrieval in case the original is accidentally erased, damaged, or destroyed.

Bad Data Block A block that cannot reliably hold data because of a media flaw or damaged format markings.

Base Plate An aluminum die casting that acts as the support platform for the other modules and for the tape drive enclosure. The base plate includes the precision mounting holes used to install SDLT tape drives into a server or tape library.

Bezel (Also known as the faceplate.) A plastic panel that extends the face of a tape drive so that it covers a computer's tape drive bay opening. The internal model of tape has two bezels: a library bezel and an internal bezel.

BIOS Basic Input/Output System. A set of routines that work closely with the hardware to support the transfer of information between various elements of the system, such as memory, disks, and peripheral devices.

Block A sector or group of sectors. SDLT 600 supports block sizes up to 16 MB.

BOM or BOT Beginning of Media or Beginning of Tape. The physical beginning of the media.

BRC Backward-read Compatibility is the ability of a current tape drive product to read cartridges written on earlier model tape drives.

BSMI Bureau of Standards, Metrology, and Inspection (Taiwan).

Buckling Mechanism The buckling mechanism engages the media leaders on cartridge load and disengages them on cartridge unload.

Buffer An area of RAM reserved for temporary storage of data that is waiting to be sent to a device. The data is usually on its way to or from the tape drive or some other peripheral device.

Bus The part of a chip, printed circuit board, or interface designed to send and receive data.

C

C The degree Celsius (°C) is a unit of temperature.

Cache Specialized RAM used as a buffer between a fast CPU or I/O channel and storage which has a relatively slow access time (for example, cartridge or diskette), to avoid slowing down the former.

Cartridge Receiver At media insertion, the cartridge receiver assembly is responsible for guiding the media into its operating position, opening the door, unlocking the cartridge brakes, and securing the media for operation. At media ejection, the cartridge receiver assembly reverses the process and automatically ejects the cartridge a fixed distance from the front of the tape drive.

CE Council of Europe.

Compressed Capacity Capacity after data has been processed, using either software or hardware, to reduce storage space while maintaining data integrity. (See also Data Compression.)

CFR Code of Federal Regulations (United States).

CSA Canadian Standards Association, also known as CSA International.

CTM Cartridge Tape Module. The main function of the SDLT's CTM is to provide the magnetic recording media used by the tape drive to store customer information. The CTM also provides the protective cartridge, which allows the media to be removed and stored safely.

CUP Code Update (a firmware update).

D

Data Compression A process that reduces the amount of storage space required to hold a particular block of data. Data transfer speed and total media capacity are affected by the data compression achieved. In accordance with industry practice, a typical compression ratio is 2:1 of data storage. Actual compression ratios achieved depend on the redundancy of data files being written.

dB A Decibel is a logarithmic unit of sound intensity; 10 times the logarithm of the ratio of the sound intensity to some reference intensity.

DC Direct Current is the continuous flow of electricity through a conductor such as a wire from high to low potential.

DCM The Data Control Module provides the path and guides for all media motion inside the tape drive and to write data to and read data from the media.

Device According to the SCSI specification, multiple SCSI devices can be connected to a single SCSI bus. Each SCSI device contains a SCSI ID number that can be set in the range 0 to 15.

Device Driver A low-level (usually kernel-mode) operating system component that enables a PC to communicate with peripheral devices such as printers, CD-ROMs, and tape drives. Each kind of device requires a different driver.

Differential A term referring to the electrical characteristics of the signal used on the SCSI bus interface. Differential signals minimize the effect of common mode signal noise and allow the SCSI bus to operate reliably over greater distances at a higher speed.

DLT Digital Linear Tape.

DLT/ce Quantum's firmware compliance management function of DLTsage, which provides secure archival functionality to the tape drive and tape cartridges.

DLTSage Quantum's suite of preventative maintenance diagnostic software tools that enables users to more simply manage tape storage environments.

DLZ Digital Lempel-Ziv 1 Algorithm is named after Abraham Lempel and Jacob Ziv. It is a data compression technique used in all SDLT tape drives.

E

EEC European Economic Community.

EEPROM Electronically Erasable Programmable Read-Only Memory. An integrated circuit memory chip that can store programs and data in a non-volatile state. These devices store firmware in DLT and SDLT tape drives, and can be erased and reprogrammed with new data.

EIM The Electronic Interface Module provides the main control function for the system and the interface from the system to the host computer, library, or autoloader.

EMC Electromagnetic Compatibility.

EMI Electromagnetic Interference.

EN EN standards are voluntary technical standards of the European Union and European Economic Area.

Encoding (n.) Characters (or bytes) of information converted to magnetic patterns on the media. (v.) The process of converting to the desired pattern.

EOD End of Data. Location on media where the last session stopped.

EOM or EOT End of Media or End of Tape. Logical EOM allows space to complete a write operation; physical EOM signifies that the media is completely used.

Erase The removal of data from media.

Error A message that occurs when there is a loss of ability to interpret recorded data; usually because of magnetic issues or defects in or on the media.

ESD An Electrostatic Discharge is a sudden flow of electric current through a material that is normally an insulator.

EU European Union.

F

F Fahrenheit is a temperature scale where a degree Fahrenheit (°F) is 5/9ths of a kelvin (or of a degree Celsius).

FCC Federal Communications Commission (United States).

Fibre Channel A high-speed serial architecture that allows either optical or electrical connections at data rates from 265 MB to 2 Gb per second. Fibre Channel is sometimes abbreviated FC.

Firmware Permanent or semi-permanent instructions and data programmed directly into the circuitry of a programmable read-only memory or electronically erasable programmable read-only memory chips. Used for controlling the operation of the computer or tape drive. Distinct from software, which is stored in random access memory and can be altered with ease.

FPM The Front Panel Module (also known as the bezel) is a plastic panel that extends the face of a tape drive so that it covers a computer's tape drive bay opening.

FUP Firmware Update.

G

GB Gigabyte

SI – 1,000,000,000 bytes or 10^9 . This is the International System of Units (SI) definition commonly used by telecommunications and storage manufacturers.

GiB – 1,073,741,824 bytes, equal to 1024^3 , or 2^{30} . This is the definition often used in computer science, computer programming, and in the majority of computer operating systems documentation. This measurement can be abbreviated as GiB (gibibyte) to avoid ambiguity, as defined in IEC 60027-2.

Note: For the purpose of this document we are using SI.

GS German Safety.

H

Head The tiny electromagnetic coil and metal pole used to create and read back the magnetic patterns on the media. Also known as the read/write head.

HiFN An ASIC (Application Specific Integrated Circuit) for the SDLT that handles data compression.

HIM The Host Interface Module implements the interface between the host system and the tape drive.

HRE Hard Read Error.

HWE Hard Write Error.

I

ICM The Integrated Controller Module contains the main controller and servo microprocessor, the custom-designed SDLT ASICs, and the cache memory.

IEC The International Electrotechnical Commission is a standards organization that prepares and publishes international standards for all electrical, electronic, and related technologies.

IEEE Institute of Electrical and Electronics Engineers

Interface A hardware or software protocol—contained in the electronics of the media controller and tape drive—that manages the exchange of data between the tape drive and computer. The most common interfaces for small computer systems are AT (IDE) and SCSI.

ISO The International Organization for Standardization is an international non-governmental standard-setting body made up of representatives from national standards bodies.

ISV Independent Software Vendor.

J

Jumper A tiny connector box that slips over two pins that protrude from a circuit board. While in place, the jumper connects the pins electrically. The jumper can be moved to change electrical connections.

K

KB A kilobyte is a unit of measure equal to 1 thousand (1024) bytes.

L

LED Light Emitting Diode.

LGMR Laser Guided Magnetic Recording.

LVD Low Voltage Differential signalling is an electrical signalling system that can run at high speeds over cheap, twisted-pair copper cables.

M

µM A Micrometer is an SI unit of length. It is defined as one millionth of a metre (1×10^{-6} m), equivalent to one thousandth of a millimeter.

MAM Medium Auxiliary Memory (MAM) is an SDLT 600 tape drive feature that provides information on the status and prior use history of an DLTtape cartridge.

MB Megabyte

SI – 1 000 000 bytes or 10^6 bytes. This is the International System of Units (SI) definition used by telecommunications engineers and storage manufacturers.

1 048 576 bytes - 1024^2 , or 2^{20} . This definition is often used in computer science and computer programming, when talking about the size of files or computer memory. The reason is that computers use the binary numeral system internally.

Note: For the purpose of this document we are using SI.

MRC Heads Magneto Resistive Cluster Heads. A cluster of small, cost-effective Magneto Resistive (MR) media heads packed densely together.

ms A Millisecond is equal to one thousandth of a second.

MTBF Mean Time Between Failures.

N

Native Capacity The capacity of a given media product in its basic recording format (without the use of data compression).

Native Mode Refers to the uncompressed storage capacity of a media subsystem. (See Native Capacity.)

Node In referring to a Fibre Channel network, a node is any device attached to the network.

P

Parity A method of generating redundant information that can be used to detect errors in stored or transmitted data.

Peripheral A device added to a system as a complement to the basic central processing unit (CPU), such as a disk drive, tape drive, or printer.

Port In referring to a Fibre Channel network, a port connects a node to the network.

Positive Engagement Buckling Mechanism A highly robust, solidly engineered media leader-buckling mechanism for heavy-duty-cycle automated environments.

POST Power-on Self-Test. When power is applied to the tape drive, it performs a POST.

PRML Partial Response Maximum Likelihood is a method for converting the weak analog signal from the head of a magnetic disk drive into a digital signal. Also see [Advanced PRML](#).

PWA Printed Wiring Assembly.

Q

QEZ An Application Specific Integrated Circuit (ASIC) for the SDLT 600 tape drive.

R

Restore To replace data on the hard drive with data obtained from another media device.

RoHS Restrictions on Hazardous Substances is an EU directive that restricts, and in some cases bans, the use of certain compounds in the manufacture of electronic equipment. RoHS mandates that new electrical and electronic equipment put on the market does not contain lead, mercury, cadmium, hexavalent chromium, poly-brominated biphenyls (PBB), or poly-brominated diphenyl ethers (PBDE).

S

SAN Storage Area Network.

SCSI Small Computer System Interface. An American National Standards Institute (ANSI) standard for the interface between a computer and peripheral controllers.

SDLT Super Digital Linear Tape.

Seek The movement of a read/write head to a specific data track.

Server A powerful computer system with a large tape drive capacity that serves the information access and communication needs of multiple users.

Shelf Life The length of time that media can be stored without losing its magnetic strength. For Super DLTtape II media, this period is 30 years or more.

SI The International System of Units.

SRAM Static RAM. A memory chip that requires power to hold its content.

T

Take-up Reel The reel inside every tape drive onto which DLTtape or Super DLTtape media is wound. The in-the-tape drive take-up reel enables DLTtape and Super DLTtape systems to operate using a single-reel cartridge and thereby pack more media and data into every cartridge.

TapeAlert™ A firmware feature that monitors and returns the results of the tape drive's on-going self-diagnosis activity.

Tape Path The path through which media moves from the cartridge, past the read/write head, and onto the take-up reel.

TCM The Tape Control Module implements the functions required to buckle and unbuckle the media and control the media motion.

Termination A physical requirement of the SCSI bus. A terminator is a device that attaches to both ends of an electrical bus and prevents reflection or echoes of signals that reach the end of the bus.

Track A linear or angled pattern of data written on a media surface. SDLT tape drives write information on multiple tracks simultaneously.

Transfer Rate The speed at which the data moves between a host (that is, tape drive) and a recorded device. Usually expressed as bytes/sec or bits/sec.

TTL Transistor-to-Transistor Logic is a class of digital circuits built from bipolar junction transistors (BJT), diodes, and resistors. It is the base for the semiconductor integrated circuit (IC) technology.

TUR Tape Unit Ready (see also [Take-up Reel](#)).

U

UL Underwriters Laboratories is a testing laboratory, which develops standards for consumer products, chiefly dealing with product safety.

Unformatted Capacity The total number of usable bytes on the media, including the space that will be required later to record location, boundary definitions, and timing information. (See also Native Capacity.)

Ultra320 An SDLT 600 tape drive SCSI interface that provides a low-voltage differential (LVD) mode running up to 160 MB/sec.

USB Universal Serial Bus is a serial bus standard for connecting devices to a computer.

V

V A Volt is the potential difference across a conductor when a current of one ampere dissipates one watt of power.

VCCI Voluntary Control Council for Interference by Information Technology Equipment (Japan).

W

W The Watt is the SI derived unit of power.

WEEE Waste Electronic and Electrical Equipment is an EU directive that mandates that producers of electronic goods assume the responsibility of recycling WEEE and create sustainable development programs to design more easily reusable and recyclable products.

WORM Write Once Read Many is a functionality, which provides secure archived records needed for government compliance.

X

XEZ An Application Specific Integrated Circuit (ASIC) for the SDLT 600 tape drive.

Quantum

141 Innovation Drive
Irvine, CA 92617
(949) 856-7800
(800) 284-5101
December 2005
81-81184-03



81-81184-03 REV A01