

Operator Guide Operator Guide Operator Guide Operator Guide Operator Guide

Scalar® 10K Tape Library

Scalar 10K

Scalar 10K Tape Library Operator Guide, 6-00058-05 Rev. A, September 2007, Product of USA.

Quantum Corporation provides this publication “as is” without warranty of any kind, either express or implied, including but not limited to the implied warranties of merchantability or fitness for a particular purpose. Quantum Corporation may revise this publication from time to time without notice.

COPYRIGHT STATEMENT

Copyright 2007 by Quantum Corporation. All rights reserved.

Your right to copy this manual is limited by copyright law. Making copies or adaptations without prior written authorization of Quantum Corporation is prohibited by law and constitutes a punishable violation of the law.

TRADEMARK STATEMENT

Quantum, the Quantum logo, Scalar, DLT, DLTtape, and the DLTtape logo are registered trademarks of Quantum Corporation in the U.S.A. and other countries. LTO and Ultrium are trademarks of HP, IBM and Quantum in the U.S.A. and other countries. Other trademarks are the property of their respective companies.

Contents

1

About This Guide

About This Guide	1-3
Product Safety Statements	1-3
GS Mark (Germany Only)	1-3
Mechanical Locks	1-4
Main Power Switch	1-4
Barcode Scanner	1-4
Disposal of Electrical and Electronic Equipment	1-5
Product Model Number	1-5
Explanation of Symbols and Notes	1-6
Other Documents you Might Need	1-8
Getting More Information or Help	1-8

2

System Description

General Description	2-3
---------------------------	-----

Capacity-On-Demand Configuration	2-4
Customer-Specific Configuration	2-4
Dual Aisle Configuration	2-4
Modules	2-5
Control Module	2-6
Accessor Module	2-6
Expansion Module	2-6
Drive Module	2-7
Tower Module	2-7
Internal Components	2-8
Tape Drives	2-8
Storage Assemblies	2-10
Cartridge Accessor	2-12
Tape Cartridges	2-13
Insert/Eject Station	2-14
Connectivity	2-16
SAN Connectivity	2-16
SCSI Connectivity	2-18
Scalar DLC	2-19
Single Server	2-19
Redundant Servers	2-20
Remote Library Management	2-22

3

Operation

Overview	3-3
Using the Operator Panel	3-3
Starting the Scalar 10K	3-7
Shutting Down the Scalar 10K	3-8
Normal Shutdown	3-8
Emergency Shutdown	3-9
Restarting the Scalar 10K	3-10
Using the Remote Management Unit	3-10
Supported Browsers	3-11
RMU Prerequisites	3-11
Setting up the RMU	3-12

Accessing and Logging Into the RMU	3-13
Checking Status and General Information	3-14
Configuring Network Parameters	3-15
Configuring SNMP	3-15
Downloading the SNMP MIB File	3-16
Configuring RMU Users	3-17
Adding/Removing Users	3-17
Changing a Password	3-18
Configuring the Time and Date	3-18
Synchronizing with an NTP Server	3-19
Updating Firmware	3-19
Viewing Diagnostic Files	3-20
Using the Operator Panel (via the RMU)	3-20
Viewing Logs	3-21
Getting Help	3-21
Rebooting the RMU	3-21

4

Menus and Commands

Overview	4-5
Using the Operator Panel	4-5
Operator Panel Buttons	4-5
Special Characters or Cursors	4-6
Help Button	4-7
Operator Intervention Message	4-7
Operator Panel Menu Tree Structure	4-8
Main Menu	4-9
Mode Dialog	4-10
Status Menu	4-12
Library Submenu	4-12
SCSI Submenu	4-13
Mode Params Dialog	4-13
Element Address	4-14
Mixed-Media Support	4-15
Parity	4-17
LCD	4-18
Reservations Dialog	4-19
System Dialog	4-21
Element Dialog	4-22
Logs Submenu	4-25

Command Log Dialog	4-26
Error Log Dialog	4-26
Print Log Dialog	4-27
Print Inventory Dialog	4-28
Firmware Submenu	4-29
Drives Submenu	4-30
Drive State Dialog	4-31
Media Info Dialog	4-35
Drive Log Dialog	4-36
Firmware Dialog	4-37
Towers Submenu	4-38
IE Stations Dialog	4-39
Commands Menu	4-40
Park	4-40
Move Submenu	4-41
Position Gripper Dialog	4-42
Position Scanner Dialog	4-44
Move Media Dialog	4-46
Inventory Dialog	4-49
Insert/Eject Submenu	4-51
Insert Screen	4-52
Insert Clean Tape Dialog	4-53
Eject Dialog	4-56
Eject Clean Tape Dialog	4-58
Database Menu	4-60
Media Dialog	4-60
Element Dialog	4-61
Config Dialog	4-63
Setup Menu	4-64
Library Submenu	4-64
Trace Submenu	4-65
SCSI Submenu	4-66
Target ID Dialog	4-67
Parity Dialog	4-68
Ports Dialog	4-69
Host Dialog	4-70
Security Submenu	4-71
User Security	4-72
I/E Security	4-74
Reset Passwords	4-76
Media Dialog	4-77
Capacity Submenu	4-79
Storage Dialog	4-80
RMU Submenu	4-82
Host Dialog	4-83
IP Dialog	4-83
More Submenu	4-84

Advanced Dialog	4-84
Inventory Dialog	4-86
Drives Submenu	4-87
ID Dialog	4-88
Tape Alert Notification Dialog	4-91
Tape Alert Notify Configuration Dialog	4-92
Logical Serial Number	4-94
Cleaning Submenu	4-94
IE Station Submenu	4-95
Drives Dialog	4-96
Media Dialog	4-97
View Dialog	4-98
Utils Menu	4-99
Library Submenu	4-99
Screen Dialog	4-100
Audio Dialog	4-102
Time Dialog	4-103
Snap Shot Screen	4-104
Date Dialog	4-104
Speed Dialog	4-105
Lights Dialog	4-105
Drives Submenu	4-106
Status Change Submenu	4-106
Initialize Dialog	4-107
Activate Dialog	4-108
Vary Off Dialog	4-109
Vary On Dialog	4-110
Operations Submenu	4-111
Update Microcode Dialog	4-112
Clean Drives Dialog	4-114
Unload Drives Dialog	4-116
Dismount Drives Dialog	4-118
Towers Submenu	4-120
Status Change Dialog	4-120
Initialize Dialog	4-122
Service Menu	4-123
Start Dialog	4-123
Diags Submenu	4-125
Accessor Submenu	4-126
Move Dialog	4-127
Step	4-128
Trace	4-129
Gripper Submenu	4-129
Get/Put Storage Dialog	4-130
Get/Put Drives Dialog	4-133
Step Dialog	4-135
Test Dialog	4-136
Scanner Submenu	4-136

Verify Dialog	4-137
Trigger Dialog	4-138
Fiducial Test Dialog	4-139
Tower Submenu	4-140
Home Dialog	4-140
Step Dialog	4-142
DI/DO Submenu	4-143
Loopback Dialog	4-143
Sensors Submenu	4-145
Wrap Dialog	4-146
Real Time	4-147
Locks Dialog	4-150
Self Test Dialog	4-151
P/S Submenu	4-152
Library Power	4-152
UDS Power	4-153
Library Submenu	4-154
Storage Move	4-154
Corner Moves	4-155
Teach Submenu	4-156
New Dialog	4-156
Continue Dialog	4-158
Current Dialog	4-159
Bays Dialog	4-162
Drive Dialog	4-164
Gripper Dialog	4-166
Tape Dialog	4-168
SAC Dialog	4-168
Demo Dialog	4-169
Verify Submenu	4-171
All Dialog	4-171
Report Dialog	4-172
Advanced Submenu	4-172
About Screen	4-173

5

Processing Media

Overview	5-3
Tape Cartridge Maintenance	5-3
Inspecting Tape Cartridges	5-3
Handling Tape Cartridges	5-4
Storing Tape Cartridges	5-4

Acclimating Tape Cartridges	5-5
Transporting Tape Cartridges	5-5
Inserting Tape Cartridges	5-6
Inserting Tape Cartridges Using the Insert/Eject Station	5-6
Manually Bulk Loading Tape Cartridges	5-7
Standard Bulk Loading	5-7
TM Bulk Loading	5-7
Ejecting Tape Cartridges	5-11
Understanding Barcodes	5-12
Barcode Labels	5-12
Applying Labels	5-13
Barcode Label Restrictions	5-14
Cleaning Drives	5-16
Typical Cleaning Operation	5-16
Non-typical Cleaning	5-16
Inserting and Ejecting Cleaning Cartridges	5-17
Insert a Cleaning Cartridge	5-19
Eject a Cleaning Cartridge	5-21
AutoClean	5-22

6

Error Messages

Overview	6-3
Understanding Error Messages	6-3
Operator Intervention Messages	6-4
Service Action Codes	6-11
Understanding Service Action Codes and Modifiers	6-11
Service Action Code Table	6-15
Resolving a Stuck Accessor	6-40
Error Log Form	6-41
Frequently Asked Questions	6-42

Index

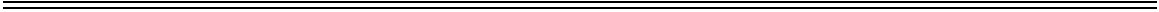

Figures

Figure 1-1	Laser Safety Label	1-5
Figure 2-1	Basic Scalar 10K System	2-3
Figure 2-2	Top View of Scalar 10K Modules	2-5
Figure 2-3	Module Cell Locations and Internal View of Library	2-9
Figure 2-4	Storage Assembly	2-10
Figure 2-5	Five Storage Assemblies per Rack (Top and Side View of EM)	2-11
Figure 2-6	Cartridge Accessor	2-12
Figure 2-7	I/E Station Magazines	2-15
Figure 2-8	Indirect Fibre Channel Attachment	2-17
Figure 2-9	Direct SCSI Attachment	2-18
Figure 2-10	Scalar DLC Network Attachments	2-20
Figure 2-11	Scalar DLC Network Attachments with Redundant Robotics	2-21
Figure 3-1	Operator Panel Components	3-4
Figure 3-2	Main Screen	3-8
Figure 3-3	Reboot Screen	3-8
Figure 3-4	RMU Location (CM Front View—Service Door Open)	3-22
Figure 4-1	Operator Panel Menu Tree Structure	4-8
Figure 4-2	Main Menu	4-9
Figure 4-3	Mode Dialog	4-10
Figure 4-4	Ready Screen	4-10
Figure 4-5	Not Ready Screen	4-11
Figure 4-6	Shutdown Screen	4-11

Figure 4-7	Status Menu	4-12
Figure 4-8	Library Submenu.	4-12
Figure 4-9	SCSI Submenu	4-13
Figure 4-10	Mode Params Dialog.	4-13
Figure 4-11	Element Address Screen.	4-14
Figure 4-12	Mixed-Media Screen	4-15
Figure 4-13	Parity Screen.	4-17
Figure 4-14	LCD Screen	4-18
Figure 4-15	Reservation Dialog	4-19
Figure 4-16	Reservation Response Screen.	4-20
Figure 4-17	System Dialog	4-21
Figure 4-18	Continuation Screen	4-21
Figure 4-19	Continuation Screen	4-22
Figure 4-20	Element Dialog.	4-22
Figure 4-21	Response Dialog	4-23
Figure 4-22	Continuation Screen	4-24
Figure 4-23	Continuation Screen	4-24
Figure 4-24	Logs Submenu	4-25
Figure 4-25	Command Log Dialog.	4-26
Figure 4-26	Error Log Dialog	4-26
Figure 4-27	Print Log Screen.	4-27
Figure 4-28	Response Screen.	4-27
Figure 4-29	Print Inventory Screen	4-28
Figure 4-30	Response Screen.	4-28
Figure 4-31	Firmware Submenu.	4-29
Figure 4-32	Drives Submenu	4-30
Figure 4-33	Drive State Dialog	4-31
Figure 4-34	Drive State Continuation Dialog.	4-31
Figure 4-35	SCSI Drive Screen	4-32
Figure 4-36	Fibre Channel Drive Screen (Dual Port).	4-32
Figure 4-37	Fibre Channel Continuation Screen (Dual Port)	4-33
Figure 4-38	Element Dialog.	4-35
Figure 4-39	Response Screen.	4-35

Figure 4-40	Drive Log Dialog	4-36
Figure 4-41	Firmware Dialog	4-37
Figure 4-42	Selected Drive Firmware Revision	4-37
Figure 4-43	Towers Submenu	4-38
Figure 4-44	IE Stations Dialog	4-39
Figure 4-45	Commands Menu	4-40
Figure 4-46	Response Dialog	4-40
Figure 4-47	Response Dialog	4-40
Figure 4-48	Move Submenu	4-41
Figure 4-49	Position Gripper Dialog	4-42
Figure 4-50	Response Screen	4-43
Figure 4-51	Response Screen	4-43
Figure 4-52	Position Scanner Dialog	4-44
Figure 4-53	Response Screen	4-45
Figure 4-54	Response Screen	4-45
Figure 4-55	Move Media Dialog	4-46
Figure 4-56	Target Dialog	4-47
Figure 4-57	Response Screen	4-48
Figure 4-58	Response Screen	4-48
Figure 4-59	Error Screen	4-48
Figure 4-60	Error Screen	4-49
Figure 4-61	Inventory Dialog	4-49
Figure 4-62	Ending Inventory Dialog	4-50
Figure 4-63	Response Screen	4-51
Figure 4-64	Response Screen	4-51
Figure 4-65	Insert/Eject Submenu	4-51
Figure 4-66	Insert Screen	4-52
Figure 4-67	Response Screen	4-52
Figure 4-68	Insert Clean Tape Dialog	4-53
Figure 4-69	Insert Range Screen	4-54
Figure 4-70	Target Screen	4-54
Figure 4-71	Usage Screen	4-55
Figure 4-72	Response Screen	4-55

Figure 4-73	Eject Dialog	4-56
Figure 4-74	Eject Screen	4-57
Figure 4-75	Response Screen	4-57
Figure 4-76	Eject Clean Tape Dialog	4-58
Figure 4-77	Eject Clean Tape Screen	4-59
Figure 4-78	Response Screen	4-59
Figure 4-79	Database Menu	4-60
Figure 4-80	Media Dialog	4-60
Figure 4-81	Response Screen	4-61
Figure 4-82	Element Dialog	4-61
Figure 4-83	Element Response Screen	4-62
Figure 4-84	Continuation Screen	4-63
Figure 4-85	Config Screen	4-63
Figure 4-86	Setup Menu	4-64
Figure 4-87	Library Submenu	4-64
Figure 4-88	Trace Submenu	4-65
Figure 4-89	Serial Port Screen	4-65
Figure 4-90	Aux Board Screen	4-66
Figure 4-91	SCSI Submenu	4-66
Figure 4-92	Target ID Dialog	4-67
Figure 4-93	Parity Dialog	4-68
Figure 4-94	Ports Screen	4-69
Figure 4-95	Host Dialog	4-70
Figure 4-96	Security Submenu	4-71
Figure 4-97	Host Dialog	4-72
Figure 4-98	Password Dialog	4-72
Figure 4-99	Host Dialog	4-73
Figure 4-100	Invalid Password	4-73
Figure 4-101	Change Password Dialog	4-73
Figure 4-102	Password Changed Screen	4-73
Figure 4-103	I/E Security	4-74
Figure 4-104	Password Dialog	4-74
Figure 4-105	Change Password Dialog	4-75

Figure 4-106	Password Changed Screen	4-75
Figure 4-107	Security is OFF Screen	4-75
Figure 4-108	Security is ON Screen	4-75
Figure 4-109	Reset Password	4-76
Figure 4-110	Reset Password Dialog	4-76
Figure 4-111	Media Dialog	4-77
Figure 4-112	Capacity Submenu	4-79
Figure 4-113	Storage Dialog	4-80
Figure 4-114	Enter Capacity Dialog	4-81
Figure 4-115	Enter Authorization Code Dialog	4-81
Figure 4-116	Acceptance Screen	4-81
Figure 4-117	Authorization Failed	4-82
Figure 4-118	RMU Submenu	4-82
Figure 4-119	Host Dialog	4-83
Figure 4-120	IP Dialog	4-83
Figure 4-121	More Submenu	4-84
Figure 4-122	Advanced Dialog	4-84
Figure 4-123	Inventory Dialog	4-86
Figure 4-124	Drives Submenu	4-87
Figure 4-125	SCSI Drive Selection	4-88
Figure 4-126	Drive Parameters (Fibre Drive Example)	4-88
Figure 4-127	Continuation Screen	4-89
Figure 4-128	Drive Parameters Screen (Port 2)	4-90
Figure 4-129	Continuation Screen (Port 2)	4-90
Figure 4-130	Tape Alert Notification Dialog	4-91
Figure 4-131	Tape Alert Notify Configuration Dialog	4-92
Figure 4-132	Logical Serial Number Dialog	4-94
Figure 4-133	Cleaning Submenu	4-94
Figure 4-134	IE Station Submenu	4-95
Figure 4-135	Drives Dialog	4-96
Figure 4-136	Media Dialog	4-97
Figure 4-137	Usage Dialog	4-97
Figure 4-138	View Dialog	4-98

Figure 4-139	Utils Menu	4-99
Figure 4-140	Library Submenu.	4-99
Figure 4-141	Screen Dialog	4-100
Figure 4-142	Timeout Value Dialog.	4-100
Figure 4-143	Password Dialog	4-101
Figure 4-144	Password Change Dialog	4-101
Figure 4-145	Invalid Password Dialog	4-101
Figure 4-146	Audio Dialog	4-102
Figure 4-147	Time Dialog	4-103
Figure 4-148	Snapshot Response Screen	4-104
Figure 4-149	Date Dialog.	4-104
Figure 4-150	Accessor Speed Screen	4-105
Figure 4-151	Lights Screen	4-105
Figure 4-152	Drives Submenu	4-106
Figure 4-153	Status Change Submenu.	4-106
Figure 4-154	Initialize Dialog	4-107
Figure 4-155	Command Complete Screen	4-107
Figure 4-156	Activate Dialog	4-108
Figure 4-157	Activate Drive	4-108
Figure 4-158	Vary Off Dialog	4-109
Figure 4-159	Vary On Dialog	4-110
Figure 4-160	Operations Submenu	4-111
Figure 4-161	Update Microcode Dialog	4-112
Figure 4-162	Starting Drive.	4-113
Figure 4-163	Ending Drive	4-113
Figure 4-164	Update Microcode Screen	4-113
Figure 4-165	Clean Drives Dialog	4-114
Figure 4-166	Progress Screen	4-115
Figure 4-167	Response Screen.	4-115
Figure 4-168	Unload Drives Dialog.	4-116
Figure 4-169	Progress Dialog	4-117
Figure 4-170	Response Dialog	4-117
Figure 4-171	Starting Drive.	4-118

Figure 4-172	Ending Drive	4-119
Figure 4-173	Progress Dialog	4-119
Figure 4-174	Response Dialog	4-119
Figure 4-175	Towers Submenu.	4-120
Figure 4-176	Set Status Dialog	4-120
Figure 4-177	Tower Mode Change.	4-121
Figure 4-178	Tower Return Dialog.	4-121
Figure 4-179	Inventory Tower	4-121
Figure 4-180	Initialize Dialog	4-122
Figure 4-181	Command Complete.	4-122
Figure 4-182	Inventory Tower	4-122
Figure 4-183	Service Menu	4-123
Figure 4-184	Preventive Maintenance Due Dialog	4-123
Figure 4-185	Confirm Change Dialog	4-124
Figure 4-186	Start Dialog with No Errors	4-124
Figure 4-187	Start Dialog with Errors	4-125
Figure 4-188	Diags Submenu	4-125
Figure 4-189	Accessor Submenu	4-126
Figure 4-190	Move Dialog	4-127
Figure 4-191	Response Dialog	4-127
Figure 4-192	Step Screen	4-128
Figure 4-193	Movement Screen	4-128
Figure 4-194	Accessor Trace Screen.	4-129
Figure 4-195	Gripper Submenu	4-129
Figure 4-196	Get/Put Storage Dialog	4-130
Figure 4-197	Continuation Dialog	4-130
Figure 4-198	Number of Elements Dialog	4-131
Figure 4-199	Response Dialog	4-131
Figure 4-200	Get/Put Drives Dialog	4-133
Figure 4-201	Continuation Dialog	4-133
Figure 4-202	Number of Drives Dialog.	4-134
Figure 4-203	Response Dialog	4-135
Figure 4-204	Step Screen	4-135

Figure 4-205	Test Screen	4-136
Figure 4-206	Scanner Submenu	4-136
Figure 4-207	Verify Dialog	4-137
Figure 4-208	Response Screen.	4-138
Figure 4-209	Fiducial Test Dialog.	4-139
Figure 4-210	Tower Submenu.	4-140
Figure 4-211	Home Dialog	4-140
Figure 4-212	Tower Homing.	4-141
Figure 4-213	Initialize Dialog	4-141
Figure 4-214	Command Complete.	4-141
Figure 4-215	Wrong Tower Mode	4-141
Figure 4-216	Home Dialog	4-142
Figure 4-217	Position Tower.	4-142
Figure 4-218	Wrong Tower Mode	4-143
Figure 4-219	DI/DO Submenu.	4-143
Figure 4-220	Loopback Dialog	4-143
Figure 4-221	Response Dialog	4-144
Figure 4-222	Sensors Submenu.	4-145
Figure 4-223	Wrap Dialog	4-146
Figure 4-224	Response Dialog	4-146
Figure 4-225	Real Time Screen	4-147
Figure 4-226	LSC SENSORS Real Time Results (LMC 6)	4-147
Figure 4-227	LSC SENSORS Real Time Results (LMC 4)	4-148
Figure 4-228	TCL SENSORS Real Time Results.	4-148
Figure 4-229	I/E SENSORS Real Time Results	4-148
Figure 4-230	LGR SENSORS Real Time Results	4-149
Figure 4-231	LMC 6 SENSORS Real Time Results	4-149
Figure 4-232	LMC 4 SENSORS Real Time Results	4-150
Figure 4-233	Locks Dialog.	4-150
Figure 4-234	Self \Test Dialog	4-151
Figure 4-235	Response Dialog	4-151
Figure 4-236	P/S Submenu	4-152
Figure 4-237	Library Power	4-152

Figure 4-238	UDS Power Status Screen	4-153
Figure 4-239	Library Submenu	4-154
Figure 4-240	Storage Moves Dialog	4-154
Figure 4-241	Corner Moves Dialog	4-155
Figure 4-242	Teach Submenu	4-156
Figure 4-243	Teach New Dialog	4-156
Figure 4-244	Progress Screen	4-157
Figure 4-245	Response Screen	4-157
Figure 4-246	Failed Screen	4-157
Figure 4-247	Continue Dialog	4-158
Figure 4-248	Progress Screen	4-158
Figure 4-249	Response Screen	4-158
Figure 4-250	Failed Screen	4-159
Figure 4-251	Teach Current Dialog	4-159
Figure 4-252	Starting and Ending Dialog	4-160
Figure 4-253	Progress Screen	4-160
Figure 4-254	Response Screen	4-161
Figure 4-255	Failed Screen	4-161
Figure 4-256	Bays Dialog	4-162
Figure 4-257	Continue Dialog	4-162
Figure 4-258	Progress Screen	4-162
Figure 4-259	Response Screen	4-163
Figure 4-260	Failed Screen	4-163
Figure 4-261	Drive Dialog	4-164
Figure 4-262	Continuation Screen	4-164
Figure 4-263	Progress Screen	4-164
Figure 4-264	Response Screen	4-165
Figure 4-265	Failed Screen	4-165
Figure 4-266	Gripper Dialog	4-166
Figure 4-267	Progress Screen	4-166
Figure 4-268	Response Screen	4-166
Figure 4-269	Teach Marginal Screen	4-167
Figure 4-270	Failed Screen	4-167

Figure 4-271	Teach Tape Dialog	4-168
Figure 4-272	SAC Dialog	4-168
Figure 4-273	Enter Password Dialog	4-169
Figure 4-274	Demo Dialog	4-169
Figure 4-275	Include Drives Dialog	4-170
Figure 4-276	Response Dialog	4-170
Figure 4-277	Verify Submenu	4-171
Figure 4-278	All Dialog	4-171
Figure 4-279	Report Screen	4-172
Figure 4-280	Response Screen	4-172
Figure 4-281	Advanced Submenu	4-172
Figure 4-282	About Screen	4-173
Figure 5-1	Towers Submenu	5-7
Figure 5-2	Set Status Dialog	5-8
Figure 5-3	Tower Mode Change	5-8
Figure 5-4	Set Status Dialog	5-8
Figure 5-5	Set Status Dialog	5-9
Figure 5-6	Tower Mode Change In Progress	5-9
Figure 5-7	Inventory Tower	5-10
Figure 5-8	Tower Inventory In Progress	5-10
Figure 5-9	Requested Command Complete	5-10
Figure 5-10	Barcode Label Application (LTO Example)	5-13
Figure 5-11	Barcode Label Examples	5-14
Figure 5-12	Media Dialog	5-17
Figure 5-13	Usage Dialog	5-18
Figure 5-14	View Dialog	5-18
Figure 5-15	Insert Clean Tape Dialog	5-19
Figure 5-16	Range Dialog	5-19
Figure 5-17	Enter Target Dialog	5-19
Figure 5-18	Current Dialog	5-20
Figure 5-19	Command Complete Dialog	5-20
Figure 5-20	Insert Clean Tape Dialog	5-21
Figure 5-21	Eject In Progress	5-21

Figure 5-22	Complete Dialog	5-21
Figure 5-23	Cleaning Submenu	5-22
Figure 5-24	AutoClean Dialog	5-22
Figure 6-1	UDS Full and Half-Height Drive Bay/Drive Location Numbering	6-13
Figure 6-2	3590 and 3592/TS11210 Drive Bay/Drive Location Numbering . .	6-14

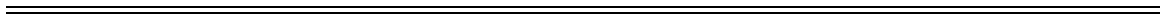

Tables

Table 1-1	Hazard Alert Message	1-6
Table 3-1	Operator Panel Indicators	3-5
Table 3-2	Operator Panel Push Buttons.....	3-5
Table 3-3	Insert/Eject Station Indicators.....	3-6
Table 4-1	Operating State and Mode	4-11
Table 4-1	Tape Alerts	4-92
Table 6-1	Operator Intervention Messages.....	6-4
Table 6-2	Service Action Codes	6-15
Table 6-3	Error Log Reporting	6-41



1

About This Guide

About This Guide	1-3
Product Safety Statements	1-3
GS Mark (Germany Only)	1-3
Mechanical Locks	1-4
Main Power Switch	1-4
Barcode Scanner	1-4
Product Model Number	1-5
Explanation of Symbols and Notes	1-5
Other Documents you Might Need	1-7
Getting More Information or Help	1-8

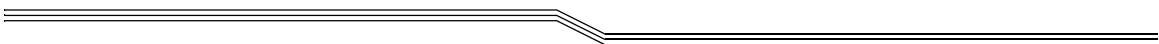



About This Guide

This manual contains information and instructions necessary for the safe operation of the Scalar 10K¹ library.

This guide is intended for Scalar 10K operators, trained customer specialists, and service partner maintenance personnel.

Be sure to read all operating instructions in this manual and in the *System, Safety, and Regulatory Information Guide* before operating this product.

Product Safety Statements

This product is designed for data storage and retrieval using magnetic tape. Any other application is not considered the intended use. Quantum will not be held liable for damage arising from unauthorized use of the product. The user assumes all risk in this aspect.

This unit is engineered and manufactured to meet all safety and regulatory requirements. Be aware that improper use may result in bodily injury, damage to the equipment, or interference with other equipment.



Do not obstruct the top or bottom airflow by placing objects above or below the library. Do not cover ventilation areas on the library.



Before powering on or using this equipment, read the *System, Safety, and Regulatory Information Guide*. Keep the Guide for future reference.

GS Mark (Germany Only)

The Scalar 10K noise level does not exceed 85db(A) in accordance with EN292-2+A1.

Der Laermpegel des Scalar 10K ueberschreitet 85db(A) nicht, dies ist in Einklang mit EN292-2+A1.

1. Scalar 10K is a trademark of Quantum Corporation. Throughout the remainder of this document the Scalar 10K library is referred to as Scalar 10K or library.

Mechanical Locks

The access and service doors can only be opened with a key. The key should be kept by an authorized person at your company. Access to the interior of the library is both a data-integrity and safety issue.

Main Power Switch

Switching off the Main Power Switch removes all power and causes the movement electronics to shut off. All movements of the accessor stop immediately. In case of danger to personnel or property, immediately switch off the Main Power Switch. For the location of the Main Power Switch, see Figure 2-1 on page 2-3.



Except in emergencies, stop the library with the normal shutdown procedure before switching off the Main Power Switch. Quantum is not responsible for damage caused by improper use of the Main Power Switch. Such risk lies entirely with the user.



Movements of mechanical components in the library can cause serious injury. Before turning the Main Power Switch on and restarting the library, confirm that no danger exists to personnel or property.



Look into the aisle to make sure there are no obstructions or personnel present prior to applying library power. Movements of mechanical components in the library can cause serious injury.

Barcode Scanner

The Scalar 10K laser barcode scanner reads barcode labels during inventory and teach operations. The barcode scanner produces light radiation that can be harmful to your eyes. You should avoid direct exposure to the scanning beam and should never stare directly into the beam aperture.

The barcode scanner is a Class II laser product that produces 1.0 milliwatt maximum @ 670 nm wavelength.

The safety label is mounted inside each Scalar 10K module access door. See Figure 1-1.

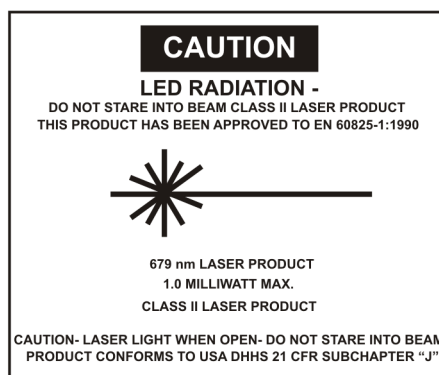
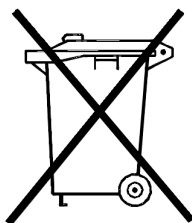

Figure 1-1 Laser Safety Label

There is no barcode scanner adjustment procedures in this guide. Only trained Quantum service personnel can perform this type of procedure.

■ Disposal of Electrical and Electronic Equipment



This symbol on the product or on its packaging indicates that this product should not be disposed of with your other waste. Instead, it should be handed over to a designated collection point for the recycling of electrical and electronic equipment. The separate collection and recycling of your waste equipment at the time of disposal will help to conserve natural resources and ensure that it is recycled in a manner that protects human

health and the environment. For more information about where you can drop off your waste equipment for recycling, please visit our website at: www.quantum.com/AboutUs/weee/Index.aspx or contact your local government authority, your household waste disposal service or the business from which you purchased the product.







■ Product Model Number

The Scalar 10K model number is: SC10K.

Explanation of Symbols and Notes

Quantum classifies hazards in several categories. Table 1-1 shows the relationship of the symbols, signal words, actual hazards, and possible consequences.

Table 1-1 Hazard Alert Message

Symbol	Damage to ...	Signal Word	Definition	Consequence
	Persons	DANGER	Imminent hazardous situation	Death or serious injury
		WARNING	Potential hazardous situation	Possible death or serious injury
		CAUTION	Less hazardous situation	Possible minor or moderate injury
	Persons		Imminent hazardous electrical situation	Death or serious injury
	Material	Caution	Potential damaging situation	Possible damage to the product or environment
	Person	Warning	Potential hazardous situation	Possible death or serious injury
	Material	Static Sensitive	Potential electronic damaging situation	Possible damage to the product
		Note	Tips for operators	No hazardous or damaging consequences
			Important or useful information	No hazardous or damaging consequences

Specially emphasized paragraphs in this guide warn of danger or draw attention to important information. These paragraphs and their associated symbols include:



The danger exists of a fatal electric shock. At places designated with this symbol, electrical current can be present. Before starting any work, always confirm that all electrical connections are free of electrical current.

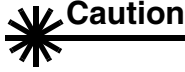

This symbol indicates the presence of a laser. Caution - use of controls or adjustments or performance of procedures other than those specified herein may result in hazardous radiation exposure.



When used with the signal word Warning, this symbol warns of a dangerous situation that threatens personnel with serious injury or death.



When used with the signal word Caution, this symbol means that specific regulations, rules, notices, and working procedures must be observed. Ignoring this symbol can lead to equipment damage or destruction or to other property damage.



This symbol indicates that the risk of equipment damage exists due to static discharge. This symbol indicates that you should refer to the "Electrostatic discharge (ESD)" section of the *System, Safety, and Regulatory Information Guide*.



This symbol draws attention to user tips. No dangerous or damaging consequences for personnel or property are associated with this symbol.



This symbol indicates important or useful information. No dangerous or damaging consequences for personnel or property are associated with this symbol.

Other documentation conventions:

<1> + <2> Press these keys simultaneously.

Italics Headline, for example, Chapter 2,
Description
File name, for example, *AMUINST.EXE*

Bold Operator panel menu selections, for example:

Main Menu ► Status ► Drives ► Firmware

Y to accept changes

N to reject changes

Courier

Operator panel menu text, for example:

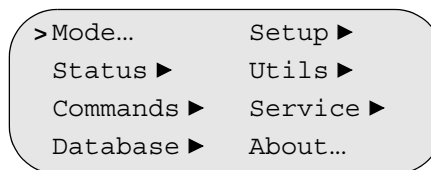

Other Documents you Might Need

The following documents are also available for this product. These documents can be found on the product CD or at www.quantum.com/ServiceandSupport/SoftwareandDocumentationDownloads/S10K/Index.aspx.

- Scalar 10K Maintenance Guide (6-00059-xx)
- Scalar 10K Planning Guide (6-01337-xx)
- Scalar 10K SCSI Reference Guide (6-01338-xx)
- System, Safety, and Regulatory Information Guide (6-00618-xx)

Release Notes are also available for this product. The Release Notes describe changes to your system or firmware since the last release, provide compatibility information, and discuss any known issues and workarounds. The Release Notes can be found in the product box or at www.quantum.com/ServiceandSupport/SoftwareandDocumentationDownloads/S10K/Index.aspx.

Getting More Information or Help

More information about this product is available on the Service and Support website at www.quantum.com/support. The Service and Support Website contains a collection of information, including answers to frequently asked questions (FAQs). You can also access software, firmware, and drivers through this site.

For further assistance, or if training is desired, contact Quantum:

Quantum Technical Assistance Center in the USA: 800-284-5101

For additional contact information: www.quantum.com/support

To open a Service Request: www.quantum.com/support

For the most updated information on Quantum Global Services, please visit: www.quantum.com/support .

For the most up to date information on Quantum Global Services, please visit: www.quantum.com/support.



2

System Description

General Description	2-3
Capacity-On-Demand Configuration	2-4
Customer-Specific Configuration	2-4
Dual Aisle Configuration	2-4
Modules	2-5
Control Module	2-6
Accessor Module	2-6
Expansion Module	2-6
Drive Module	2-7
Tower Module	2-7
Internal Components	2-8
Tape Drives	2-8
Storage Assemblies	2-10
Cartridge Accessor	2-12
Tape Cartridges	2-13
Insert/Eject Station	2-14
Connectivity	2-16
SAN Connectivity	2-16
SCSI Connectivity	2-18
Scalar DLC	2-19
Single Server	2-19
Redundant Servers	2-20
Remote Library Management	2-22

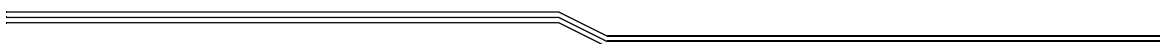

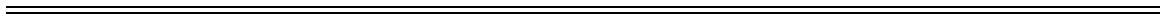

General Description

The Scalar 10K is a tape storage library that can be configured as a single-media or mixed-media library. It can be expanded from a single-module library to a multiple-module library. See Figure 2-1.

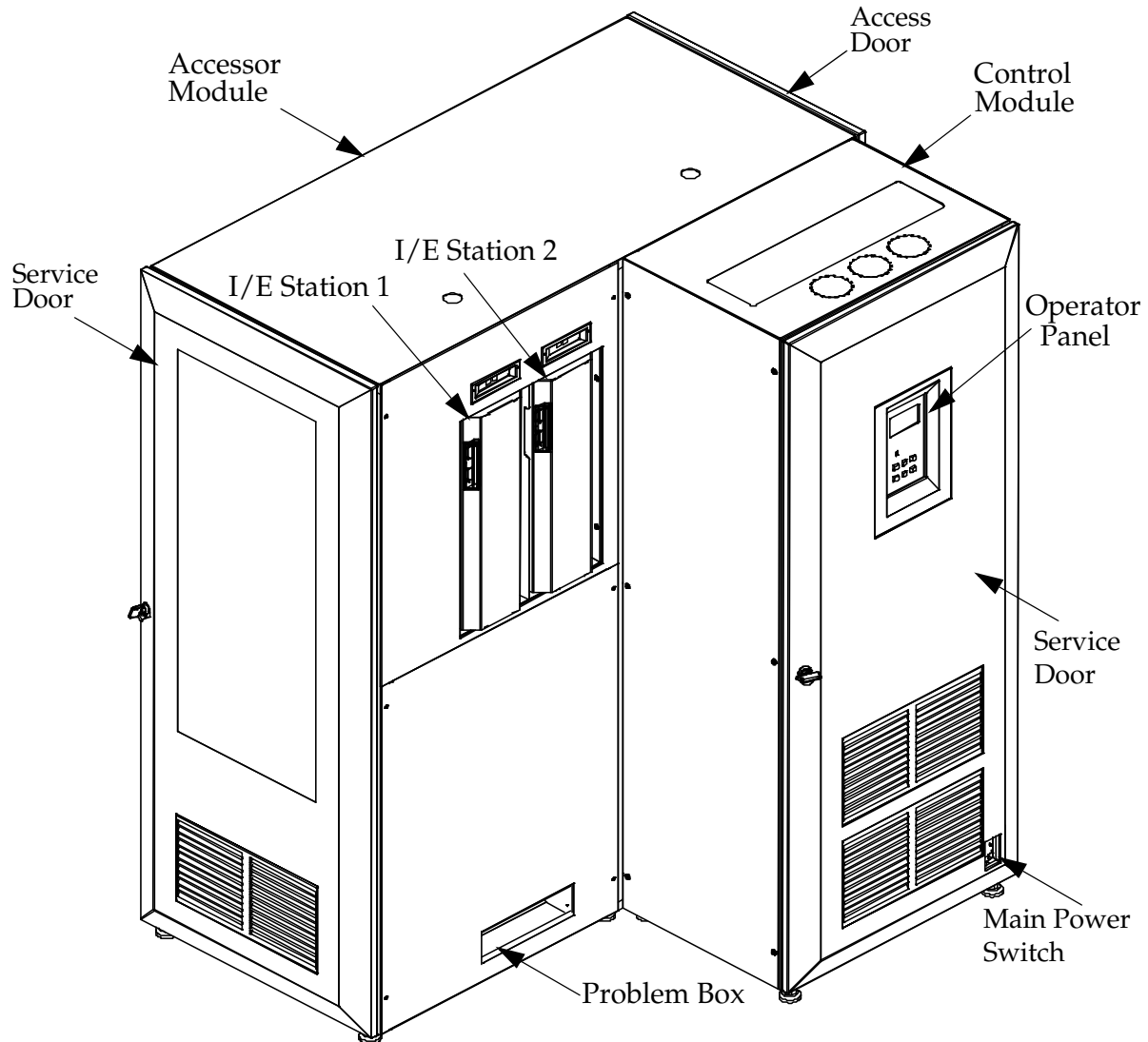

Figure 2-1 Basic Scalar 10K System

The Scalar 10K automates the storage, retrieval, and control of the following tape cartridges:

- LTO-1
- LTO-2
- LTO-3
- LTO-4
- DLT
- Super DLT (SDLT)
- 8 mm
- 1/2-inch tape cartridges

Cartridges are mounted and unmounted in tape drives using application software from the host without operator intervention.

The Scalar 10K can be configured as a Capacity-on-Demand (COD), Customer-Specific, or Dual Aisle configuration.

Capacity-On-Demand Configuration

In a COD configuration, you receive a fully-populated library but do not use all storage slots. This gives you room to expand in the future. To enable the unused storage slots, contact Quantum to obtain a software key. The COD configuration can be configured for 700 to 5,403 tape slots.

Customer-Specific Configuration

In a Customer-Specific configuration, the library is built to customer specifications. This type of configuration can contain up to 15,000 tape slots and up to 624 tape drives.

Dual Aisle Configuration

The Dual Aisle configuration includes redundant controllers, redundant accessors, redundant control paths, and redundant shared tower storage, making the configuration a highly-available system. If one aisle goes down, the other aisle remains available.

The Dual Aisle configuration can be configured for up to 22,938 tape slots and up to 624 tape drives.

Modules

The Scalar 10K consists of five different modules: a Control Module (CM), Accessor Module (AM), Expansion Module (EM), Drive Module (DM), and Tower Module (TM). For an example of the five different modules, see Figure 2-2.

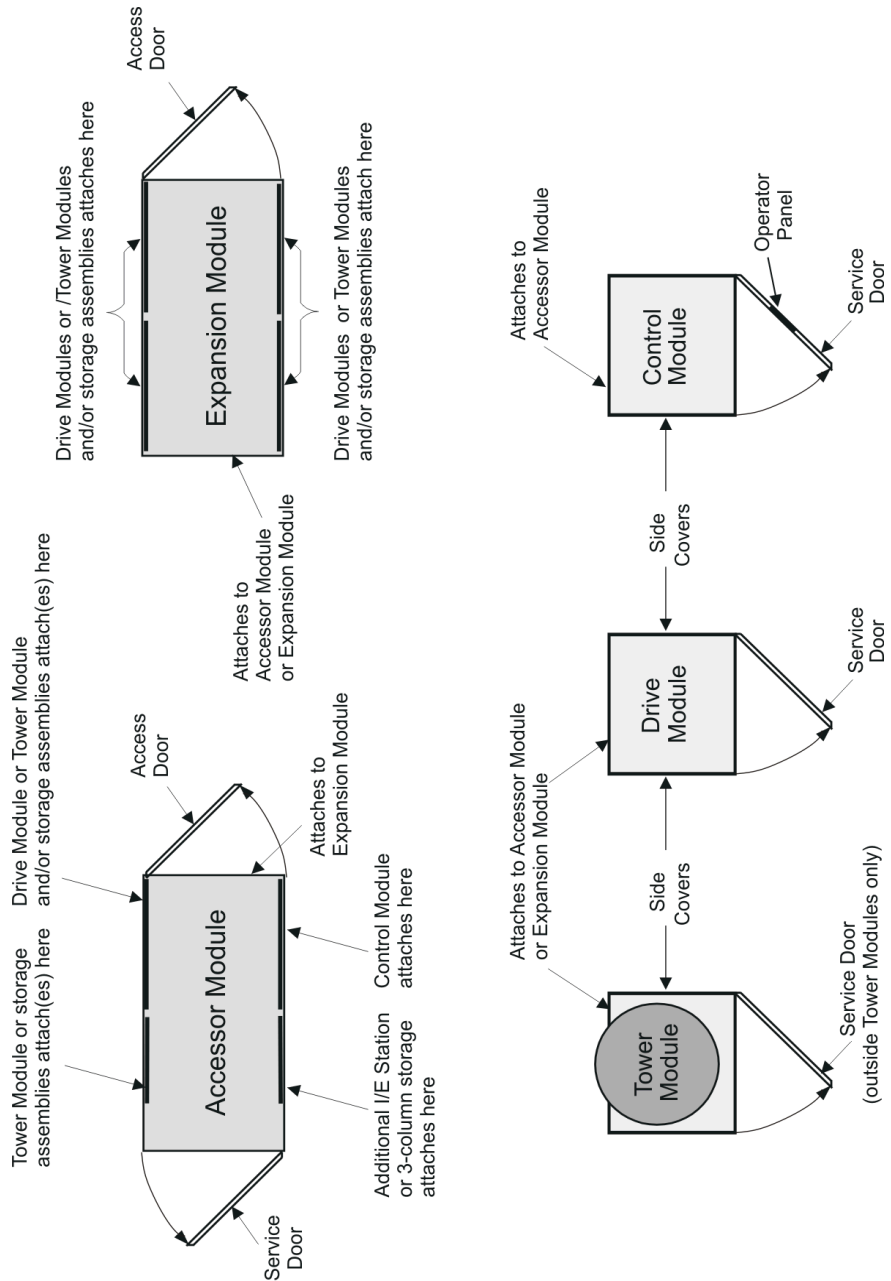



Figure 2-2 Top View of Scalar 10K Modules

Control Module

The CM is one of the fundamental building blocks required in every library. The CM contains an operator panel, AC and DC power supplies, robot control electronics, and host interfaces.

 **Note**
3590 and 3592-J1A tape drives are not supported in a CM.3592-J1A/TS1120

Each CM drive bay has the space equivalent of 60 LTO, 50 DLT/SDLT, 75 8 mm, or 50 1/2-inch cartridges. Each drive bay accommodates from 1–6 DLT/SDLT or LTO tape drives, or 1–12 AIT tape drives.

In a Dual Aisle configuration, CMs are used with the primary aisle and secondary aisle.

Accessor Module

The AM is another fundamental building block that is required in every library. The AM contains the robotics system (one per single aisle, two per dual aisle). The AM has two doors, a service door on one end and an access door on the other end. If one or more EMs are attached to the AM, the access door is relocated to the last EM. The AM requires a CM, a minimum of one Insert/Eject (I/E) station, and storage assemblies. A minimum Dual Aisle configuration includes two AMs, two CMs, and two inside TMs. The AM contains attachment areas for feature modules or storage assemblies.

In a Dual Aisle configuration, a safety barrier is included that allows for concurrent maintenance by trained service personnel.

Expansion Module

The EM is a feature module and is added as requirements change. The EM extends the length of the aisle and allows the library to be expanded to accommodate additional drive and cartridge requirements. A Scalar 10K maximum configuration includes three EMs. These modules extend the X-rails (top and bottom) which allow the accessor to travel the length of the library. Each EM has four attachment areas (racks) that can be used to attach feature modules or storage assemblies as shown in Figure 2-2 on page 2-5.

When EMs are used in a Dual Aisle configuration, two inside TMs attach to each EM, leaving two attachment areas (racks) that can be used to attach feature modules or storage assemblies. A maximum Dual Aisle configuration includes six EMs.

Drive Module

The DM is also a feature module and is added as requirements change. The DM is attached to an AM or EM. The DM contains its own AC power compartment and drive communication electronics. It can be configured with one to four drive bays. Each drive bay accommodates from 1–6 DLT/SDLT or LTO tape drives, 1–12 AIT tape drives, 1–2 3590 tape drives, and 1–4 3592-J1A/TS1120 tape drives.

Different types of drives can be intermixed in a DM with the exception of 3592-J1A/TS1120 drives. 3592-J1A/TS1120 drives require a special DM that is only compatible with 3592-J1A/TS1120 drives.

In a Dual Aisle configuration, DMs can be attached to the EMs of primary aisle and secondary aisle.

Tower Module

The TM is a feature module and is also added as requirements change. The TM is attached to an AM or EM. The TM contains a storage tower and control electronics and is configured for only one media type. TMs can be bulk loaded or unloaded through the TM service door.

Maximum TM capacity depends on the media type loaded. See Table 2-1.

Table 2-1 TM Capacity

Media Type	Cartridge Capacity
LTO	660
DLT/SDLT	552
8 mm ^a	1,104
1/2-inch ^b	552

a. The 8 mm media type is used in AIT tape drives.

b. The 1/2-inch media type is used in 3590 and 3592-J1A/TS1120 tape drives.

In a Dual Aisle configuration, two TMs are required between each AM or EM. Optionally, TMs can be attached to the EMs on the primary aisle and secondary aisle.

Internal Components

Figure 2-3 on page 2-9 shows the inside of a Scalar 10K. The Scalar 10K consists of the following functional units:

- Tape Drives
- Storage Assemblies
- Cartridge Accessor
- Tape Cartridges
- I/E Station

Tape Drives

 **Note**
Quantum SDLT supports SDLT media and DLT Type IV media.

The Scalar 10K supports the following tape drives:

- IBM LTO-1 LVD - SCSI
- IBM LTO-1 FC Multimode
- IBM LTO-2 LVD - SCSI
- IBM LTO-2 FC Multimode
- IBM LTO-3 FC Multimode
- IBM LTO-4 FC Multimode
- Quantum DLT 8000 LVD - SCSI
- Quantum SDLT 220 LVD - SCSI
- Quantum SDLT 320 LVD-SCSI
- Sony AIT-2 LVD - SCSI
- Sony AIT-3 LVD - SCSI
Drive firmware 0201_CY12 and later supports both re-writable and Write Once Read Many (WORM) cartridges. Earlier versions of drive firmware support only re-writable cartridges.
- IBM Magstar 3590
- IBM 3592-J1A/TS1120
Drive firmware supports both re-writable and Write Once Read Many (WORM) cartridges.
- IBM TS1120

The Universal Drive Sled (UDS) tape drives are enclosed in a UDS chassis. The UDS contains control electronics, a cooling fan, and is equipped with a self-docking connector through which it receives library power (+5 VDC and +12 VDC) and signal communications.

For information on drive bay and drive location numbering, see Figure 6-2 on page 7-14.

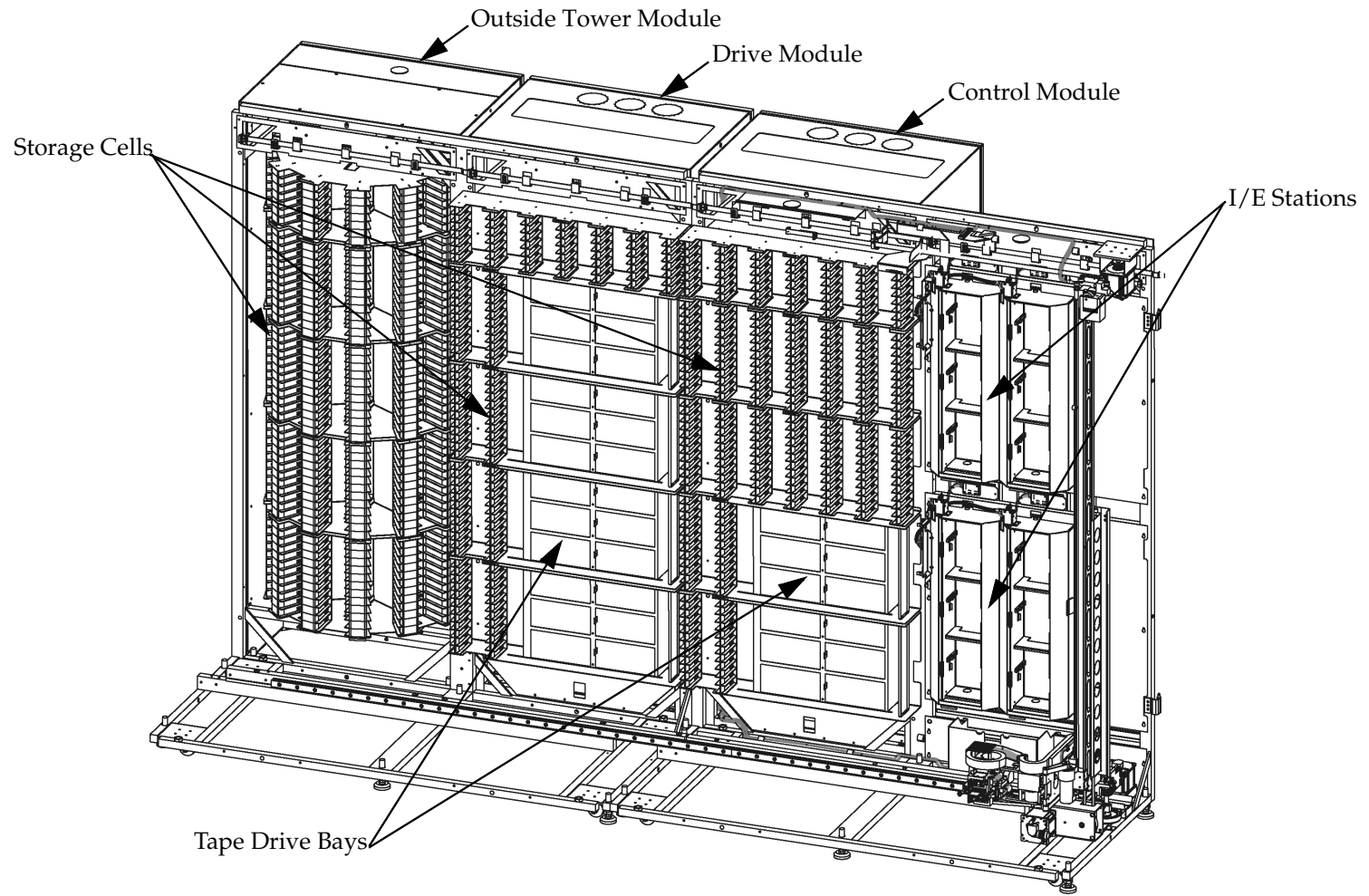

Figure 2-3 Module Cell Locations and Internal View of Library

Storage Assemblies

A storage assembly (Figure 2-4) is a modular storage assembly that holds tape cartridges. An AM or EM has four attachment areas called racks. Each rack contains a series of storage assemblies. See Figure 2-5 on page 2-11.

Each AM or EM rack can support total slot capacities as indicated in Table 2-2 on page 2-11.

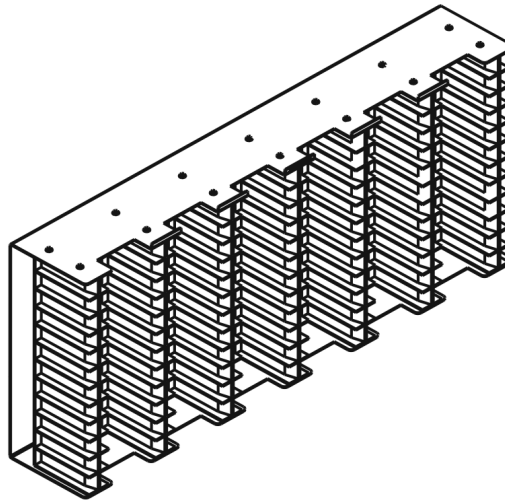
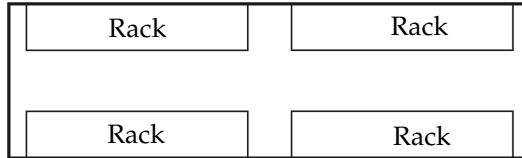

Figure 2-4 Storage Assembly

Each rack is divided into five sections counting from top to bottom as shown in Figure 2-5 on page 2-11.

Top View of EM



Side View of EM

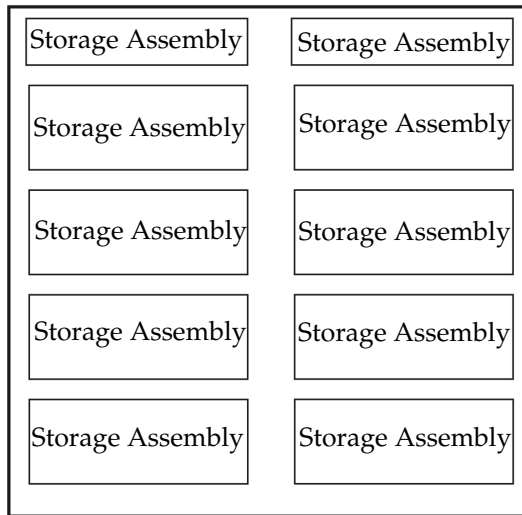

Figure 2-5 Five Storage Assemblies per Rack (Top and Side View of EM)

Table 2-2 Rack Capacity

Media Type	Cartridge Capacity per Rack
LTO	330
DLT/SDLT	276
8 mm ^a	414
1/2-inch ^b	276

a. The 8 mm media type is used in AIT tape drives.

b. The 1/2-inch media type is used in 3590 and 3592-J1A/TS1120 tape drives.

Cartridge Accessor

The cartridge accessor (Figure 2-6) identifies and moves cartridges between the storage cells, tape drives, and I/E Stations. The cartridge accessor has:

- A gripper assembly containing a cartridge gripper and the barcode scanner. The gripper is designed to pivot horizontally 180°, get and put cartridges in storage cells, tape drives, or the I/E station. The gripper fingers are designed to have full range control for open/close to handle different media types. The barcode scanner reads the external barcode labels on the cartridges. It is also used during the inventory process to locate and categorize all storage arrays, drive bays, and drives installed in the library.
- An X-axis drive for moving the gripper assembly the length of the rails in the AM and EM(s).
- A Y-axis drive for moving the gripper assembly vertically in the CM, AM, and EM(s).

In a Dual Aisle configuration, the primary aisle and secondary aisle each have their own cartridge accessor.

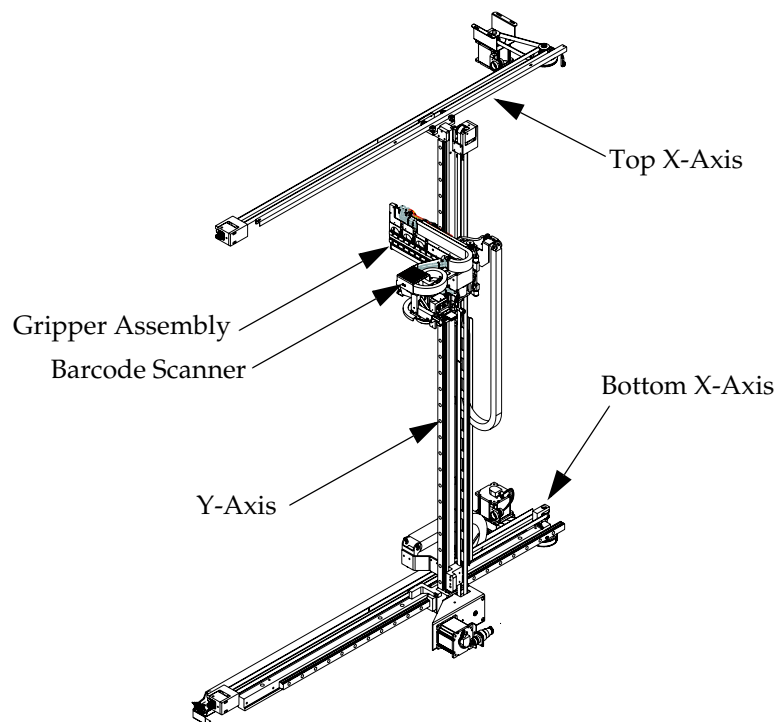

Figure 2-6 Cartridge Accessor

Tape Cartridges

A tape cartridge is identified by an attached operator and machine readable barcode label. This label, depending on the operating mode, has a minimum of 5 and a maximum of 16 barcode characters.

The Scalar 10K operates in one of three modes:

- Default Mode - six characters
- Mixed Media Mode - six characters, plus a media identifier
- Extended Mode - 5 to 16 characters, may include media identifiers and checksum values

The barcode is composed of uppercase A to Z characters and numeric 0 to 9 characters. The Scalar 10K currently supports Code 39 type labels.

In Mixed Mode, the seventh or eighth characters on the label identify the cartridge type. The additional characters (listed below) are added to the end of the standard barcode label:

- C = DLT CompacTape III
- D = DLT CompacTape IV
- S = SDLT CompacTapeIVXT
(The C, D, or S characters are included on the same label in addition to the six character barcode.)
- E = 3590E
- J = 3590
- JA, JJ, JR, or JW = 3592-J1A/TS1120
- JB, JX = TS1120
- L1 = LTO-1
- L2 = LTO-2
- L3, LT = LTO-3
- L4 = LTO-4

The 8 mm media barcode labels do not support a media identifier at this time. However, the Scalar 10K designates the character *A* as a media identifier for reporting purposes.



Cartridges can be inserted incorrectly (upside down) in a storage location or in the I/E station. The barcode reader reads the barcode label correctly and the gripper operates normally, but the system fails when the gripper attempts to put the cartridge into a drive.

For additional information on barcode labels, refer to *Barcode Labels* on page 6-12.



Insert/Eject Station

The I/E Station allows you to move a cartridge without interrupting normal library operation. The I/E Stations are installed on the AM as shown in Figure 2-2 on page 2-5.

In the S10K COD configuration, one pair of I/E stations is included.

In the S10K Customer-Specific configuration, one pair of I/E stations is included and an additional pair is optional.

In a Dual Aisle configuration, each aisle includes one pair of I/E stations and an additional pair is optional for each aisle.

Each I/E station has three removable cartridge magazines. See Figure 2-7 on page 2-15.

Each I/E station also includes an area designated as the Problem Box where the gripper can deposit a problem cartridge to be retrieved by the operator. This is required for continuous operation. The Problem Box is designed to accommodate any cartridge size that Scalar 10K supports.

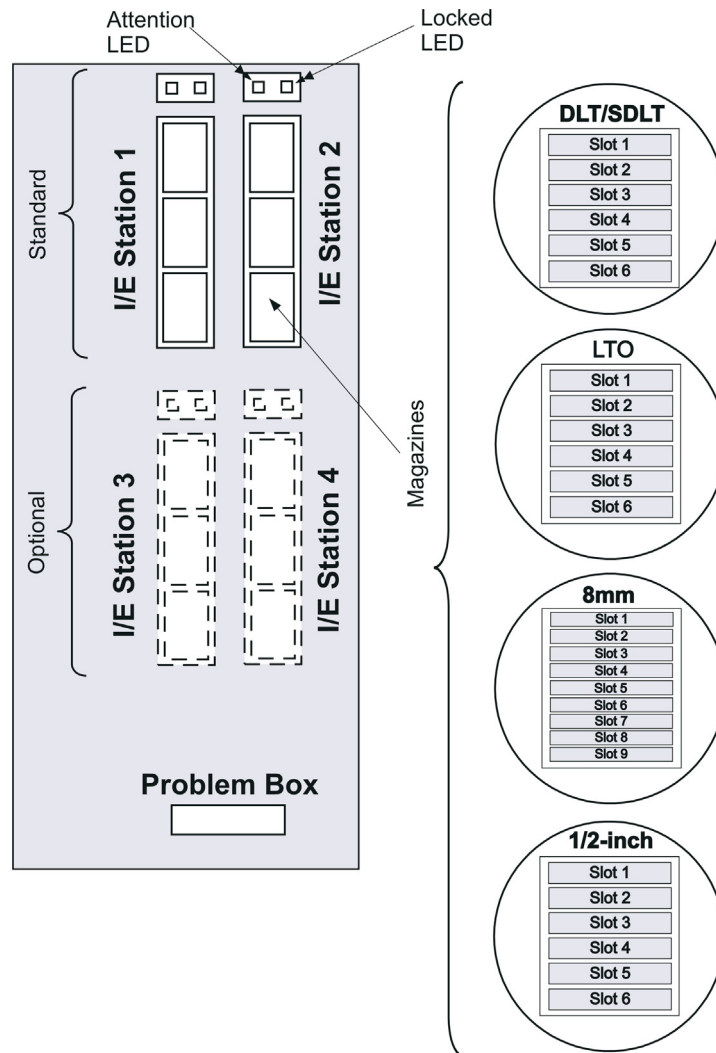

Figure 2-7 I/E Station Magazines

Connectivity

The Scalar 10K offers several different connectivity options, allowing the library to support a wide range of backup topologies and applications. Flexible library connectivity delivers active support for loop and switched fabric Fibre Channel protocols, along with SCSI.

SAN Connectivity

The Scalar 10K can be connected to a Fibre Channel Storage Area Network (SAN) via the Storage Network Controller (SNC). See Figure 2-8 on page 2-17.

The SNC provides four SCSI bus connections, one ethernet, and two Fibre Channel connections. The SNC allows native SCSI devices (for example: library controller and tape drives) to be seen by any hosts that are attached to the SAN.

The library controller and the tape drives access the SAN via the SNCs, which can be installed in a Scalar 10K CM or a DM. LTO drives can also attach to the SAN through the Native Fibre Channel interface available.

For Dual Aisle configurations, the Scalar DLC controls the cartridge accessors and the SNC controls the tape drives.

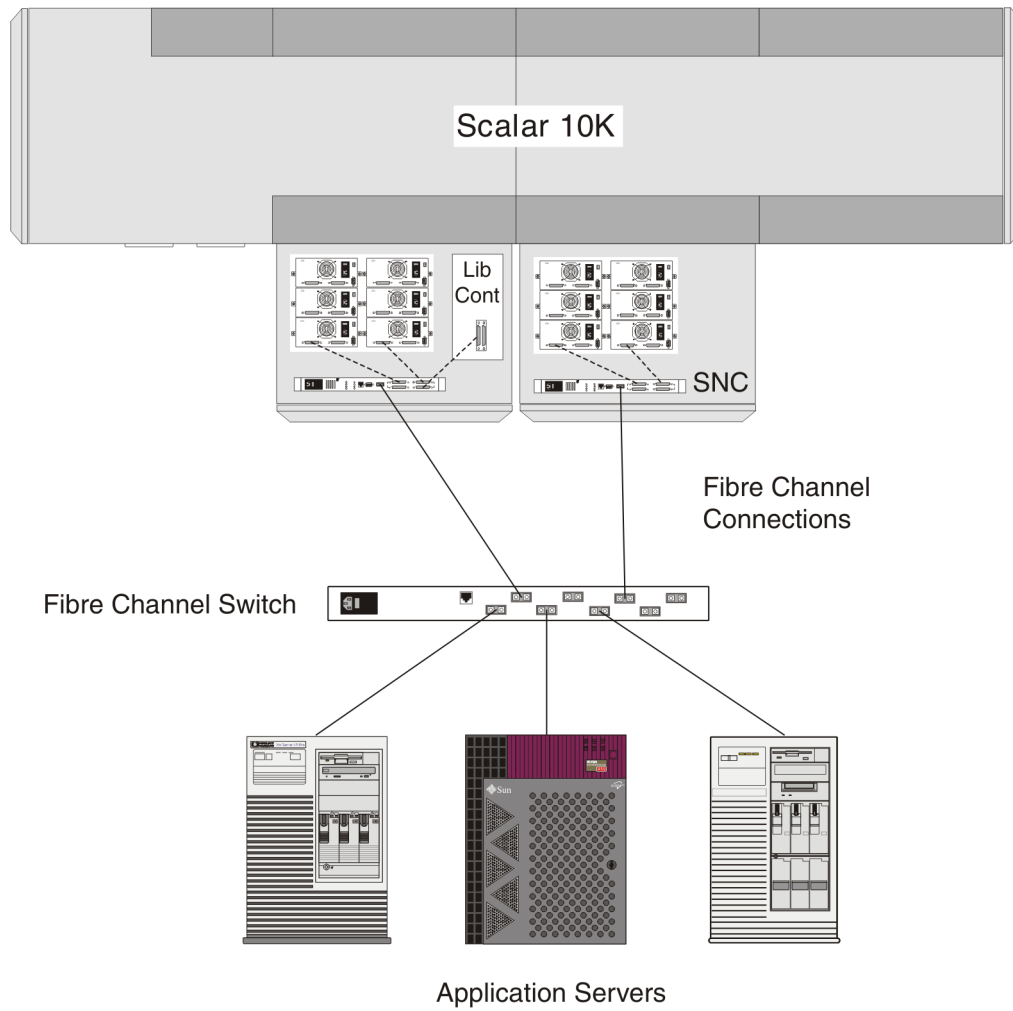

Figure 2-8 Indirect Fibre Channel Attachment

SCSI Connectivity

The Scalar 10K library can be directly connected to one or two SCSI buses. See Figure 2-9. Because each SCSI bus is independent, it can be Single Ended or Differential. Both ends of each bus must be terminated. A terminator is shipped with each SCSI adapter card ordered.

The minimum configuration of a Scalar 10K library requires one SCSI adapter. The SCSI type (Single Ended or Differential) must be specified at the time of order.

Although the Scalar 10K can be attached to a wide SCSI bus, it is not a wide SCSI device and its SCSI ID must be in the range of 0 to 7.

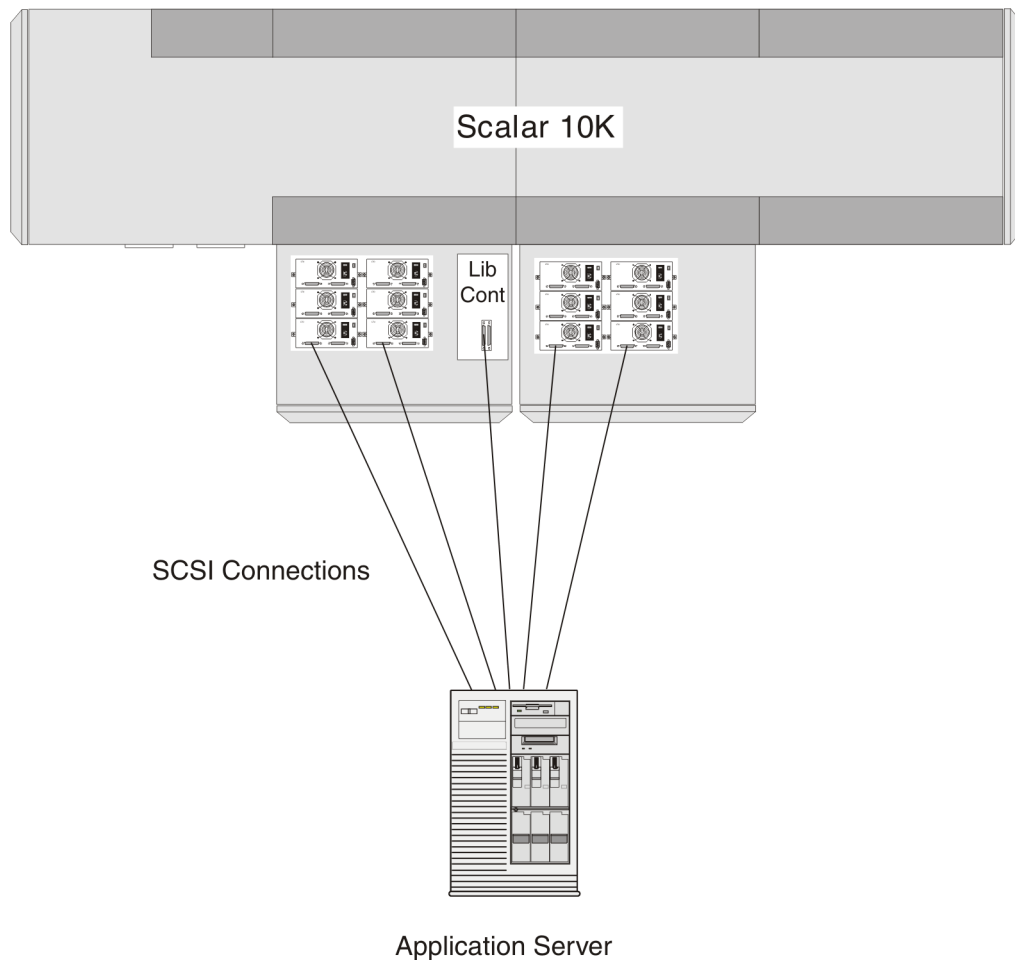

Figure 2-9 Direct SCSI Attachment

Scalar DLC

The Scalar 10K, through its Scalar Distributed Library Control (Scalar DLC) interface, provides the industry's most advanced combination of management and diagnostics. It creates and maintains the Scalar 10K configuration, the physical location of the cartridge accessor, and the inventory of cartridges. The database is kept in flash memory of the Library control hardware.

The Scalar DLC attaches to the library SCSI bus.

The host continues to directly attach to the drives via a SCSI or an SNC Interface.

Refer to the *Scalar DLC* documentation for detailed description of the interfaces supported.

Scalar DLC is optional in COD and Customer-Specific configurations. A single server is the typical Scalar DLC option for these configurations. Refer to *Single Server* for more information.

Scalar DLC is required in a Dual Aisle configuration. Redundant servers are the typical Scalar DLC option for the Dual Aisle configuration. Refer to *Redundant Servers* on page 2-20.

Single Server

The Scalar DLC Integrated Controller for the Scalar 10K Dual Aisle library consists of Scalar DLC 2.5 or later software loaded on a rack mountable server. The server has dual SCSI drives connected to an embedded RAID controller, a LVD SCSI card for library connection, and redundant AC power supplies. The system also ships with a rack mountable flat panel LCD monitor/keyboard/mouse.

See Figure 2-10 on page 2-20.

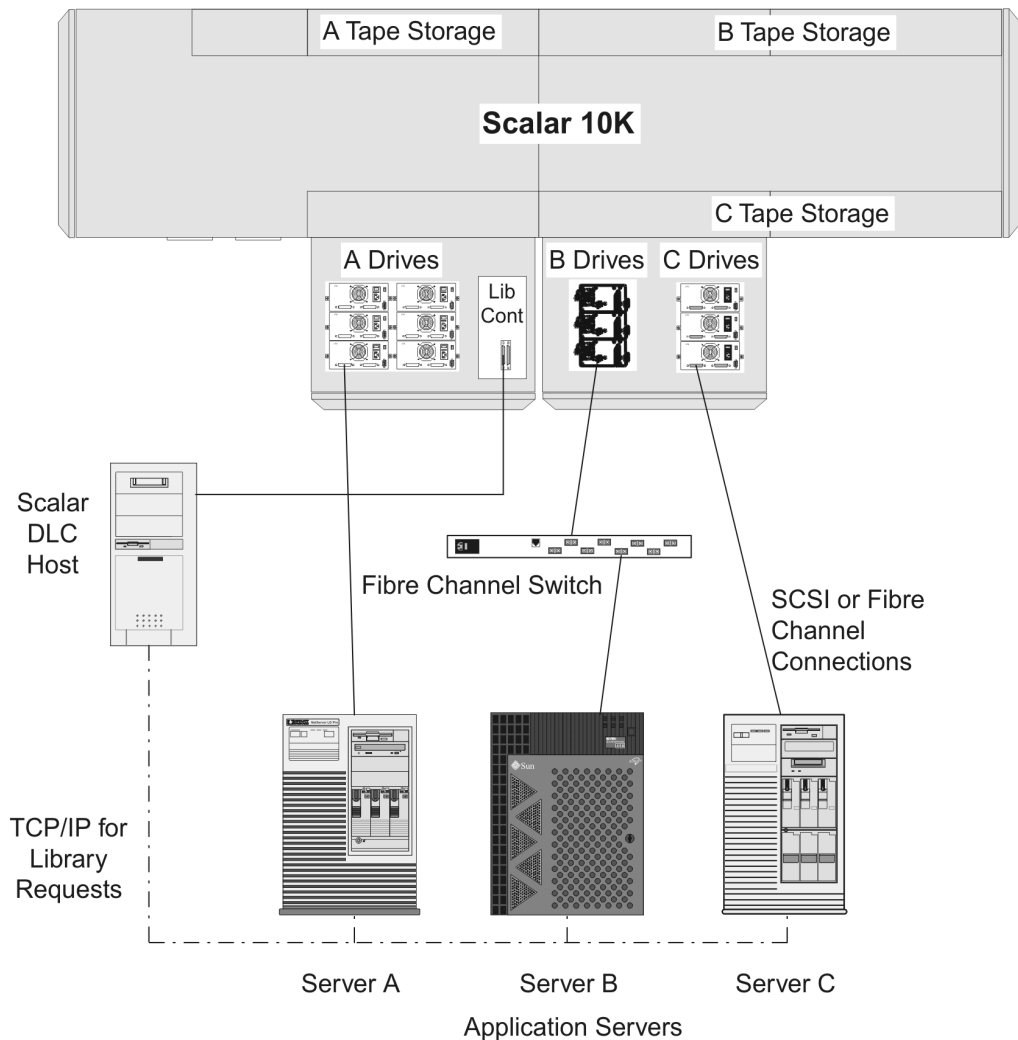

Figure 2-10 Scalar DLC Network Attachments

Redundant Servers

The redundant Scalar DLC Integrated Controller for the Scalar 10K Dual Aisle library consists of Scalar DLC 2.5 or later software loaded on two rack-mountable servers.

Each Server has Dual SCSI drives that are connected to an embedded RAID controller, 512MB memory, an LVD SCSI card for library connection, and redundant AC power supplies. In addition, each server operates with Windows Advanced Server with Microsoft Cluster Server (MSCS). With MSCS, a cluster is a configuration of two nodes, each of which is an independent computer system.

Together, these independent servers create a "server cluster." The cluster appears to users as a single server. Should the primary server fail, the secondary (passive) server automatically takes over all Scalar DLC functions. The systems also ships with a rack-mountable flat panel LCD monitor/keyboard/mouse, a rack-mountable KVM switch, a rack-mountable external RAID subsystem, and required system cabling.

See Figure 2-11.

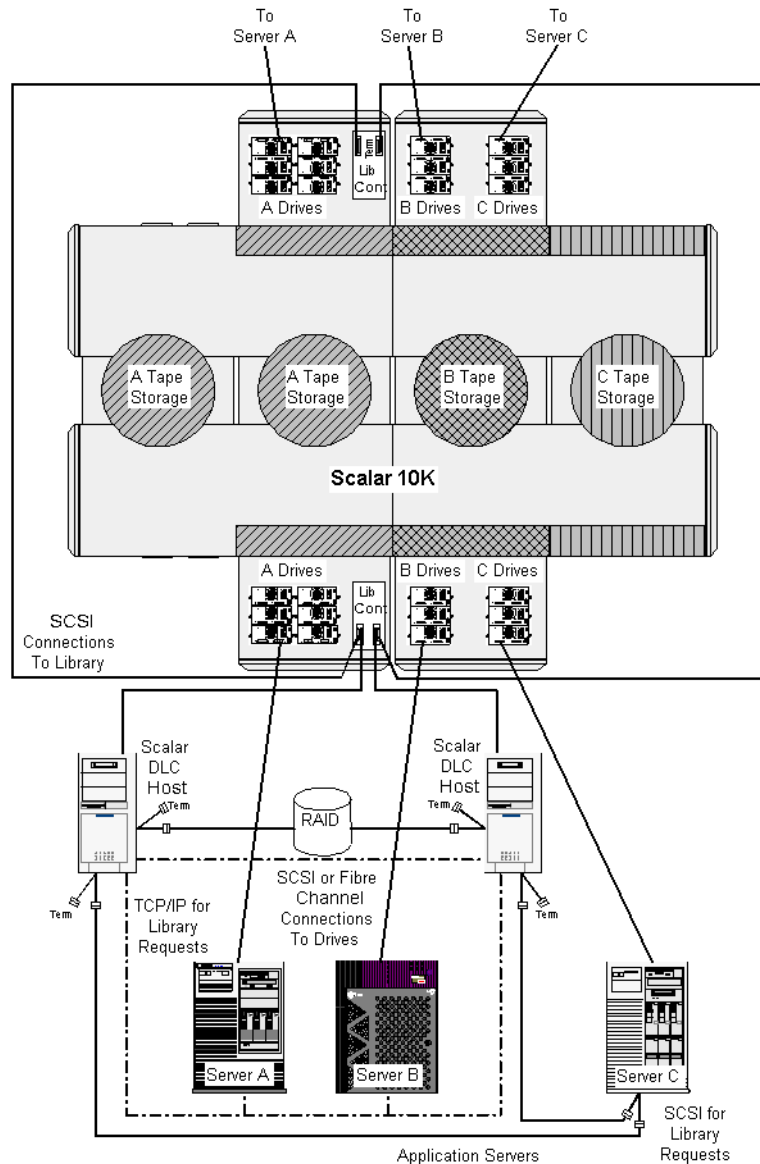

Figure 2-11 Scalar DLC Network Attachments with Redundant Robotics

Remote Library Management

The factory installed Remote Management Unit (RMU) in each system uses a standard web browser for remote library access.

The supported browsers are:

- Microsoft Internet Explorer version 5.0 and above
- Netscape Navigator version 4.01 for Unix and 4.7X for other environments

With an RMU, you are able to do the following:

- Update RMU firmware
- Access the library status
- Make configuration changes
- Access the library operator panel
- Retrieve library command and error logs
- Use the Quantum Web site to access Scalar 10K documentation

The RMU supports Simple Network Management Protocol (SNMP) version 2.0 and acts as an SNMP-server. The RMU acquires Tape Alert 2.1 compatibility information from the library over the serial interface port and sends that information to a SNMP server. The RMU also detects a power loss and generates a SNMP trap for notification. For additional information, refer to *Using the Remote Management Unit* on page 4-10.

3

Operation

Overview	3-3
Using the Operator Panel	3-3
Starting the Scalar 10K	3-7
Shutting Down the Scalar 10K	3-8
Normal Shutdown	3-8
Emergency Shutdown	3-9
Restarting the Scalar 10K	3-10
Using the Remote Management Unit	3-10
Supported Browsers	3-11
RMU Prerequisites	3-11
Setting up the RMU	3-12
Accessing and Logging Into the RMU	3-13
Checking Status and General Information	3-14
Configuring Network Parameters	3-15
Configuring SNMP	3-15
Downloading the SNMP MIB File	3-16
Configuring RMU Users	3-17
Adding/Removing Users	3-17
Changing a Password	3-18
Configuring the Time and Date	3-18
Synchronizing with an NTP Server	3-19
Updating Firmware	3-19
Viewing Diagnostic Files	3-20
Using the Operator Panel (via the RMU)	3-20
Viewing Logs	3-21
Getting Help	3-21
Rebooting the RMU	3-21



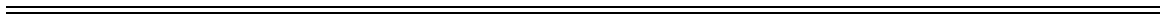

Overview

This chapter describes the Scalar 10K library operator panel, the library startup and shutdown procedures, and the Remote Management Unit (RMU).

Using the Operator Panel

The operator panel provides an interactive path between the operator and the Scalar 10K. See Figure 3-1 on page 3-4.

The Scalar 10K operator functions are listed below:

- Starting the Scalar 10K
- Shutting down the Scalar 10K
- Handling media

Refer to *Inserting Tape Cartridges* on page 6-6 for media handling procedures. In the case of equipment failures, the operator can perform manual media processing.



Look into the aisle to make sure there are no obstructions or personnel present prior to applying library power. Movements of mechanical components in the library can cause serious injury.

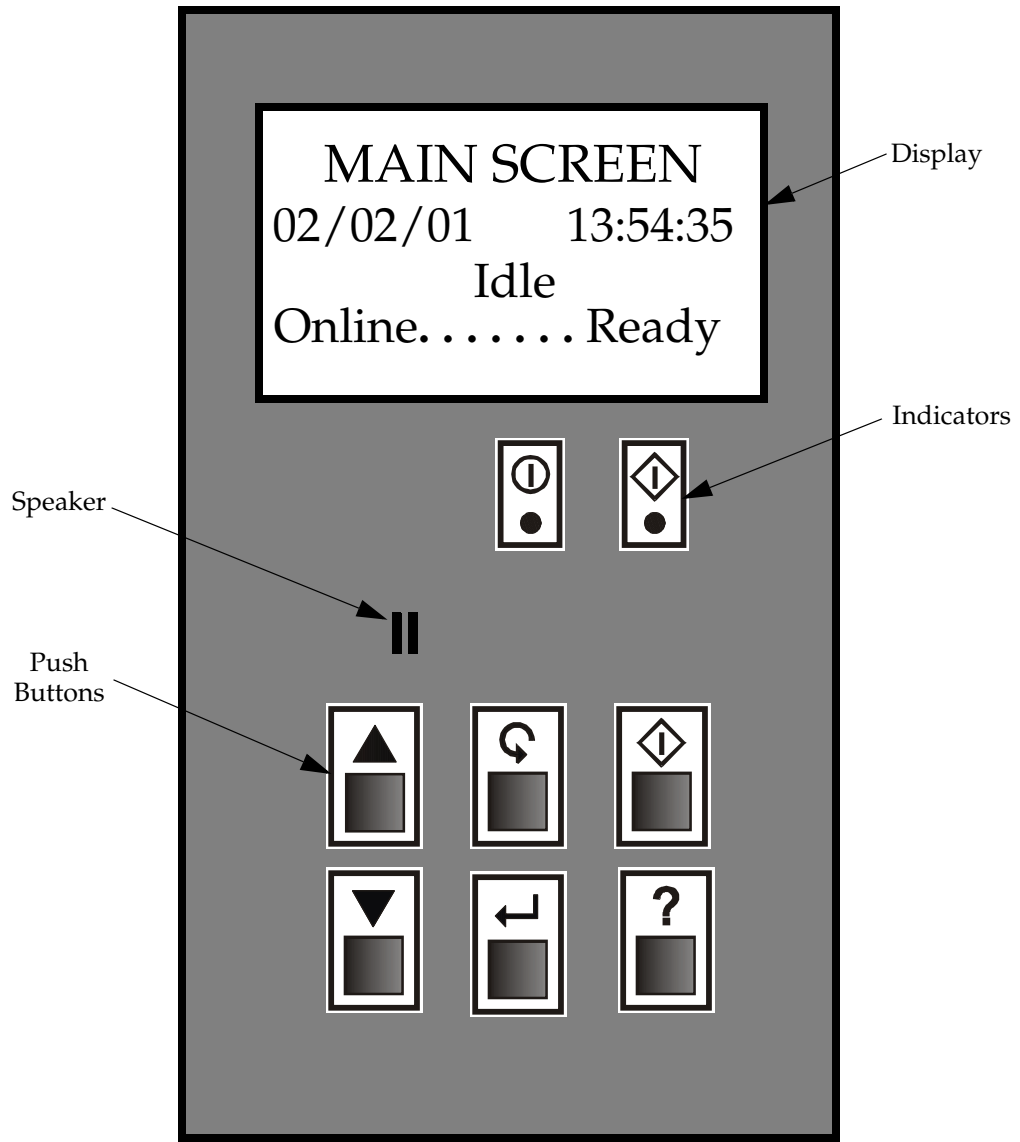

Figure 3-1 Operator Panel Components

Table 3-1 illustrates and describes operator panel indicators.

Table 3-1 Operator Panel Indicators



Indicator	Description
	<p>The Ready indicator is lit whenever Power is available in the aisle and the library is ready to perform motion commands from the host.</p>
	<p>The Power On indicator is lit whenever the Control Module is connected to an AC power source, the Control Module switch, and the AC Power Compartment circuit breakers are ON.</p>

Table 3-2 describes operator panel push buttons.

Table 3-2 Operator Panel Push Buttons





Push button	Description
	<p>Use Up Arrow to:</p> <ul style="list-style-type: none"> • scroll the display to show the previous line. • move the cursor (>) up from selection to selection. • increment the current value in a numerical entry field.
	<p>Use Down Arrow to:</p> <ul style="list-style-type: none"> • scroll the display to show the next line. • move the cursor (>) down from selection to selection. • decrement the current value in a numerical entry field.
	<p>Use Enter to:</p> <ul style="list-style-type: none"> • select the option indicated by the cursor (>) as the next action to be performed by the library. • act as a TAB button to the next required entry field when multiple field entries are being entered. In this case, the button cycles through all the entry locations until the Accept option is chosen (with Y).



Table 3-2 Operator Panel Push Buttons (Continued)

Push button	Description
	Use Escape to: <ul style="list-style-type: none"> • leave the current menu and returns to the previous menu, if it exists. • move back one menu item. • exit Help and return to the previous menu.
	Use Help to display help text for the current selected item if available. In this mode, the Arrow buttons scroll through the help text and the Escape button is used to exit Help.
	Use Ready to transition the library from a Ready state to NotReady, or NotReady to the Ready state.

Holding down the push buttons cycles through the options. The longer the push button is held down, the faster it cycles.

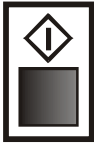
Table 3-3 provides an illustration and description of the visual indicators on the operator panel.

Table 3-3 Insert/Eject Station Indicators

Indicator	Description
	The Locked indicator is On whenever the I/E station is locked. One of the following conditions locks the I/E station: <ul style="list-style-type: none"> • The host issues a SCSI PREVENT/ALLOW MEDIUM REMOVAL command and locks the I/E station. • The Scalar 10K is accessing the I/E station.
	The Attention indicator can be in one of the following three states: <ul style="list-style-type: none"> • Off: All cartridge magazines are present and do not contain an ejected tape cartridge. • On: One or more magazines is missing, or a magazine contains an ejected tape cartridge. • Blinking: A lock command is pending and the I/E station door is not closed, or a lock command failed.

Starting the Scalar 10K

Caution

Use the following procedure to start the Scalar 10K.

With the RMU installed, power up must be delayed by one minute after a power down condition to allow the RMU to properly reset.

- Step 1** Make sure that all doors are closed and mechanically locked on the Control Module (CM), Accessor Module (AM), and Expansion Modules (EMs).
- Step 2** Locate the Power Switch at the lower right corner of the DM door.
- Step 3** Set the Power Switch on the DM to on.
- Step 4** Repeat the process for each DM.
- Step 5** Locate the Main Power Switch at the lower right corner of the CM service door.
- Step 6** Set the Main Power Switch on the CM to on.

Text appears on the operator panel.

If text does not appear, power cycle the AC power or check the library fuse or circuit breaker.

Warning

Movements of mechanical components in the library can cause serious injury. Before turning the Main Power Switch on, confirm that no danger exists to personnel or property.

Warning

Look into the aisle to make sure there are no obstructions or personnel present prior to applying library power. Movements of mechanical components in the library can cause serious injury.



Power is applied to the Scalar 10K. The CM embedded software starts the boot process. The Power On indicator illuminates and the Main Menu displays status.

After all firmware procedures complete, the LCD screen on the operator panel displays the Main Screen. See Figure 3-2 on page 3-8.

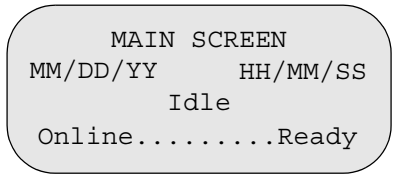

Figure 3-2 Main Screen

Shutting Down the Scalar 10K

The Scalar 10K may be shut down normally or by the Emergency Shutdown method.





Use the method described in *Emergency Shutdown* in cases of emergency only.

Normal Shutdown



Proceed as follows to shutdown the Scalar 10K:

With the RMU installed, power up must be delayed by one minute after a power down condition to allow the RMU to properly reset.

Step 1 If necessary, use the  button to return to the Main Menu. The cursor defaults to the Mode selection. Press the  button. From the Mode screen, use the  button to select the Shutdown mode.

Press the  button.

The Accessor completes the current task and returns to the home position. The reboot message appears. See Figure 3-3.

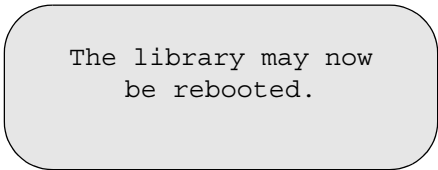

Figure 3-3 Reboot Screen

Step 2 Locate the Main Power Switch at the lower right corner of the CM.

Step 3 Set the Main Power Switch to off.

Power is removed from the CM.

Step 4 Repeat Step 2 and Step 3 for each Drive Module.

Emergency Shutdown

Warning

Use the following procedure if an emergency situation arises.

Except in emergencies, stop the Scalar 10K with the normal shutdown procedure before switching off the Main Power Switch. Quantum is not responsible for damage caused by improper use of the Main Power Switch. All risk lies entirely with the user.

Caution

With the RMU installed, power up must be delayed by one minute after a power down condition to allow the RMU to properly reset.

Step 1 Locate the Main Power Switch at the lower right corner of the CM.

Step 2 Set the Main Power Switch to off.

Power is removed from the Scalar 10K CM. All Accessor movement stops immediately and the gripper descends.

Step 3 Repeat Step 1 and Step 2 for each DM.

Restarting the Scalar 10K

Caution

Use the following procedure to restart the Scalar 10K.

With the RMU installed, power up must be delayed by one minute after a power down condition to allow the RMU to properly reset.

Warning

Look into the aisle to make sure there are no obstructions or personnel present prior to applying library power. Movements of mechanical components in the library can cause serious injury.

Step 1 If applicable, correct the situation that required the Scalar 10K shutdown.

Step 2 Refer to *Starting the Scalar 10K* on page 4-7 for instructions on the Scalar 10K start procedure.

Using the Remote Management Unit

The RMU is a component in the library that provides remote access to the library by means of a Web browser. All functions listed here are available without the need of a dedicated server (or separate software).

The RMU performs the following functions:

- Provides remote operation of all library operator panel functions by means of a Web browser.
- Allows you to check the status of the system, firmware levels, and other useful information.
- Updates RMU firmware.
- Supports Simple Network Management Protocol (SNMP) version 2.0 and acts as an SNMP-server, generating SNMP traps and responding to SNMP requests.
- Supports ADIC Library Management Information Base (MIB) version 2.0.
- Acquires Tape Alert 2.1 information from the library and sends that information to an SNMP manager.
- Detects a power loss and generates an SNMP trap for notification.
- Enables the retrieval of library logs, and drive and RMU diagnostic files.

- Allows RMU configuration changes such as network, users, and date/time.
- Provides online access to documentation.

The following screen is the opening screen of the RMU.

Library Status	
Drive Status	Offline Click for detail
RMU User	DLT: 2 drives LTO: 4 drives, 2 offline No current user
Hostname	vanessa
IP Address	172.16.104.150
MAC Address	00:30:8C:01:09:C9
Library Serial #	ADIC202100061
SNMP	Off
SNMP Alerts	Off
Library Firmware	200.a.j0529
RMU Firmware	161A.00005

Advanced Digital Information Corporation (ADIC)
 11431 Willows Road NE, PO Box 97057, Redmond, WA 98073-9757 USA
 Tel : +1 425.881.8004 USA Toll Free : 1.800.336.1233 Fax : +1 425.881.2296

Supported Browsers

The RMU supports the following browsers:

- Microsoft Internet Explorer version 5.0 and above
- Netscape Navigator version 4.01 for Unix and 4.7x for other environments

RMU Prerequisites

The RMU requires a network address that consists of an Internet Protocol (IP) address, subnet mask, and gateway IP Address.

Once you have this information, input it to the RMU by means of the operator panel. For more information, see the instructions that follow.

Setting up the RMU

Once you have obtained a network address for the RMU, enter this information into the RMU by means of the library operator panel.

Step 1 Starting from the operator panel Main Menu, go to the RMU Submenu (Main Menu ► Setup ► Library ► RMU).

The RMU Submenu is shown.

```
>Host...
IP...
```

Step 2 Select **Host**.

The Host Dialog is shown.

```
Host :

Accept : N
```

Step 3 Enter the host name using the **Up**, **Down**, and **Next** buttons.

Step 4 Select **Y** to accept the changes.

Step 5 Select **IP**.

The IP Dialog is shown.

```
IP : 100<100.100.100
Sub: 225.225.225.001
Gat: 100.100.100.100
Accept: N
```

Step 6 Enter the IP address, subnet mask, and gateway IP address using the **Up**, **Down**, and **Next** buttons.

Step 7 Select **Y** to accept the changes.

Accessing and Logging Into the RMU

Before you begin using the RMU, make certain you have configured your RMU with the correct network address.

Step 1 Open a Web browser.

Step 2 Point your browser to the RMU IP address, excluding any leading zeros. For example, if your IP address is 182.073.056.205 on the library operator panel LCD, go to the following address:
`http://182.73.56.205`.

The RMU user interface displays. Some of the features of the RMU require you to log in. Continue with Step 3 to log into the RMU.

Step 3 Log into the RMU when prompted. Enter your user name into the **User Name** field and password into the **Password** field. The user name and password are case sensitive.

 **Note**
For information on determining or setting your RMU IP address, see *Setting up the RMU* on page 4-12.

 **Note**
The default user login and password are *admin* and *secure*, respectively.



Checking Status and General Information

You can use the RMU to remotely check the status of a library and obtain general information about the library. For example, you can check drive status or get the firmware level of your library.

Step 1 Click the **Status** tab.

The following information appears:

- **Library Status** - Indicates whether the library is online or offline.
- **Drive Status** - Indicates the type and quantity of tape drives in the library.
- **RMU User** - Indicates the user name and IP address of the current user.
- **Hostname** - Indicates the hostname of the RMU.
- **IP Address** - Indicates the IP address for the RMU connection.
- **MAC Address** - Indicates the Media Access Control (MAC) address of the RMU. This is also the serial number of the RMU.
- **Library Serial #** - Indicates the library serial number.
- **SNMP** - Indicates whether SNMP requests and alerts are enabled or disabled.
- **SNMP Alerts** - Indicates whether the SNMP Alert notification feature is enabled or disabled.
- **Library Firmware** - Indicates the current level of library firmware.
- **RMU Firmware** - Indicates the current level of RMU firmware.

Configuring Network Parameters

You can reconfigure the hostname, IP address, subnet mask, and gateway address through the RMU. This feature requires you to log in to the RMU. Refer to *Accessing and Logging Into the RMU* on page 4-13 for more information.

- Step 1** Click the **Configuration** tab.
- Step 2** In the **Network Configuration** area, enter the new hostname, IP address, subnet mask, and gateway address.
- Step 3** Click **Submit** and review your changes (indicated in red).
- Step 4** Enter your password and click **Confirm** to complete the procedure.

The new values are saved. Note that you may need to redirect your Web browser if you are logged out.

Configuring SNMP

Simple Network Management Protocol (SNMP) is a set of protocols used to manage nodes on an IP network. You can configure the RMU to send alerts to and respond to requests from an SNMP management application.

To ensure event capturing and reporting, you must enable SNMP and enable the SNMP alerts.

- Step 1** Click the **Configuration** tab.
- Step 2** In the **SNMP Configuration** area, do the following:
- To enable or disable the feature, select **ON** or **OFF** in the **SNMP Enabled** drop-down.
 - To enable or disable SNMP alerts, select **ON** or **OFF** in the **Alerts Enabled** drop-down. SNMP must be enabled if you want SNMP alerts enabled.
 - In **Manager**, enter the SNMP server address.

-
-
- In **Public Name**, enter the name of the read-only SNMP community.
 - In **Private Name**, enter the name of the read/write SNMP community.

Step 3 Click **Submit** and review your changes (indicated in red).

Step 4 Enter your password and click **Confirm** to complete the procedure.

The new values are saved. Note that you may need to redirect your Web browser if you are logged out.

Step 5 Click **Done**.

You may be instructed to reboot the RMU. Refer to *Rebooting the RMU* on page 4-21 for more information.

Downloading the SNMP MIB File

The SNMP Management Information Base (MIB) file allows an SNMP management application to understand the SNMP database and alerts generated by the RMU. If you are running an SNMP management application and need the library MIB, you can download it by means of the RMU.

Step 1 Click **SNMP MIB** in the left pane of the RMU interface.

Step 2 Right-click **Download SNMP MIB** and click **Save Target As**.

Step 3 Browse to your SNMP management server and click **Save**.

You will need to load the MIB file into the SNMP management application.

Configuring RMU Users

You can add unique users to the RMU. However, only one administrator-level user is allowed, and it is automatically given the user name *admin*.

Adding/Removing Users

Only the admin account can add or remove users.

Step 1 When prompted, log in as *admin*.

Step 2 Click the **Configuration** tab.

Step 3 In the **User Configuration** area, do one of the following:

- If you are adding a user:
 - a. In the **Management Action** drop-down, click **Create User**.
 - b. In **Edit New**, enter the new user name.
 - c. In **Password**, enter the new user's password and then confirm it in **Re-enter Password**.
- If you are deleting a user:
 - a. In the **Management Action** drop-down, click **Delete User**.
 - b. In **Select One**, select the user you want to remove.

Step 4 Click **Submit** and review your changes (indicated in red).

Step 5 Enter the *admin* password and click **Confirm** to complete the procedure.

Changing a Password

At any time, you can change your RMU password. If you are the administrator, you can also change other users' passwords.

- Step 1** Click the **Configuration** tab.
- Step 2** In the **User Configuration** area, select **Change User Password** from the **Management Action** drop-down.
- Step 3** If not already selected, select the appropriate user account from the **Select One** drop-down.
- Step 4** Click **Submit** and review your changes (indicated in red).
- Step 5** Enter your password and click **Confirm** to complete the procedure.

 **Note**
Only the admin can modify another user's password.

Configuring the Time and Date

You can configure the date and time for the RMU. The date and time will be used in the RMU log file to report when events occurred.

- Step 1** Click the **Configuration** tab.
- Step 2** Enter the date and time in the **Date and Time** area.
- Step 3** Click **Submit** and review your changes (indicated in red).
- Step 4** Enter your password and click **Confirm** to complete the procedure.

Synchronizing with an NTP Server

 **Note**

If using a time server, the Scalar 10K synchronizes with the RMU.

You can connect the RMU to a network time (NTP) server to automatically set the time.

- Step 1** Click the **Configuration** tab.
- Step 2** In the **Date and Time** area, select **ON** from the **Synchronization with NTP Server** drop-down menu.
- Step 3** In the **NTP Server IP Address** field, enter the IP address of the NTP server.
- Step 4** In the **Timezone** field, enter the time zone deviation for the NTP server. To get a list of timezone offsets, click **list of timezones**.
- Step 5** Click **Submit** and review your changes (indicated in red).
- Step 6** Enter your password and click **Confirm** to complete the procedure.



Updating Firmware

You can update firmware for the RMU. Before you update firmware, you need to have the firmware file in a location that is accessible from the RMU interface. Firmware updates can be found on www.quantum.com.

- Step 1** Click the **Firmware** tab.
- Step 2** Select the firmware you would like to update.
- Step 3** Click **Browse** and browse to the location of the firmware update file.
- Step 4** Click **Update Firmware**.

 **Note**

Downloading firmware can take several minutes.

The firmware updates. If the RMU was selected for a firmware update, the RMU will reboot.



Viewing Diagnostic Files

From the RMU, you can view the diagnostic information for the attached library and RMU. This information can assist technical support personnel when diagnosing problems.

Step 1 Click the **Diagnostics** file tab.

Step 2 Select the file you would like to view. The available options are:

- **Library Command Log** - Provides an event (command, errors, etc.) log for the library.
- **Library Error Log** - Use the Library Command Log.
- **RMU Support Log** - Provides support logs for the RMU.
- **RMU Error Log** - Provides error logs for the RMU.

Step 3 Click **Retrieve selected file**.

The file loads.

Step 4 Click **Display File** to view the file in a separate browser window.



Using the Operator Panel (via the RMU)

The RMU provides access to the library by means of a virtual operator panel.

- Click the **Operator Panel** tab.

A graphical representation of the operator panel appears. You can click the softkeys and control the library the same way that you would from the front of the library. For more information on the operator panel, refer to *Using the Operator Panel* on page 4-3.

Viewing Logs

You can view the most current entries in the library command log without downloading the entire log file.

- Click the **Logs** tab.

The command log appears with the most recent entry at the top of the list.

Getting Help

The RMU provides access to help for the following items:

- **Contents** - Provides a description of each of the tabs on the RMU interface.
- **Documentation** - Provides a link to the user documentation for the library.
- **SNMP MIB** - Provides information on the SNMP MIB file. For more information, see *Configuring SNMP* on page 4-15.
- **Support** - Provides information on contacting technical support.
- **Version** - Provides the current revision level of the RMU firmware.

To get help

- Click on the item in the left pane of the RMU interface.

The information appears in a separate browser window.

Rebooting the RMU

Reboot the RMU when instructed by an operator panel message, a service action code (SAC) repair action, or the GCH.

See Figure 3-4 for the location of components referenced in this procedure.

Step 1 Open the CM service door.

Step 2 Unscrew the captive screw that holds the RMU in place. For the location of the captive screw, see Figure 3-4 on page 3-22.

Step 3 Slide the RMU out approximately 3 inches for approximately 15 seconds.

Step 4 Slide the RMU back into place and tighten the captive screw.

Step 5 Close the CM service door.

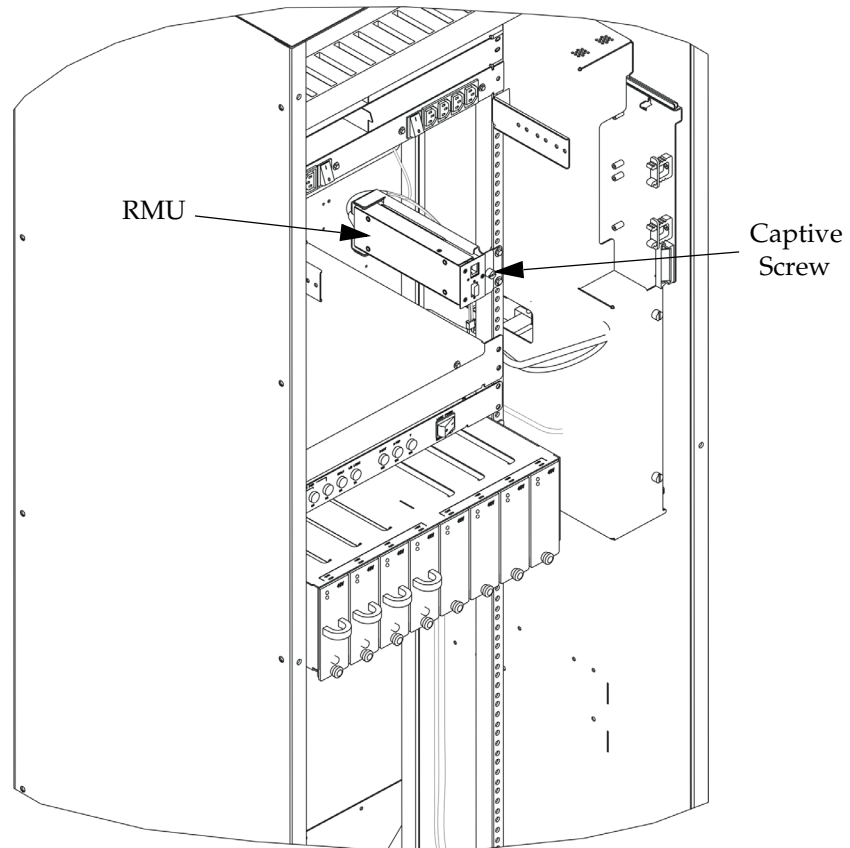

Figure 3-4 RMU Location (CM Front View—Service Door Open)

4

Menus and Commands

Overview	4-5
Using the Operator Panel	4-5
Operator Panel Buttons	4-5
Special Characters or Cursors	4-6
Help Button	4-7
Operator Intervention Message	4-7
Operator Panel Menu Tree Structure	4-8
Main Menu	4-9
Mode Dialog	4-10
Status Menu	4-12
Library Submenu	4-13
SCSI Submenu	4-13
Mode Params Dialog	4-14
Element Address	4-15
Mixed-Media Support	4-15
Parity	4-17
LCD	4-17
Reservations Dialog	4-18
System Dialog	4-19
Element Dialog	4-21
Logs Submenu	4-23
Command Log Dialog	4-24
Error Log Dialog	4-24
Print Log Dialog	4-25
Print Inventory Dialog	4-26
Firmware Submenu	4-27
Drives Submenu	4-28
Drive State Dialog	4-28
Media Info Dialog	4-31
Drive Log Dialog	4-33



Firmware Dialog	4-33
Towers Submenu	4-34
IE Stations Dialog	4-35
Commands Menu	4-36
Park	4-36
Move Submenu	4-37
Position Gripper Dialog	4-37
Position Scanner Dialog	4-39
Move Media Dialog	4-40
Inventory Dialog	4-43
Insert/Eject Submenu	4-45
Insert Screen	4-46
Insert Clean Tape Dialog	4-47
Eject Dialog	4-50
Eject Clean Tape Dialog	4-51
Database Menu	4-53
Media Dialog	4-53
Element Dialog	4-54
Config Dialog	4-56
Setup Menu	4-57
Library Submenu	4-57
Trace Submenu	4-58
SCSI Submenu	4-59
Target ID Dialog	4-60
Parity Dialog	4-61
Ports Dialog	4-62
Host Dialog	4-63
Security Submenu	4-63
User Security	4-64
I/E Security	4-66
Reset Passwords	4-68
Media Dialog	4-69
Capacity Submenu	4-71
Storage Dialog	4-71
RMU Submenu	4-73
Host Dialog	4-74
IP Dialog	4-74
Advanced Dialog	4-75
Drives Submenu	4-76
ID Dialog	4-77
Cleaning Submenu	4-80
Drives Dialog	4-81
Media Dialog	4-82
View Dialog	4-83
Utils Menu	4-84
Library Submenu	4-84
Screen Dialog	4-85

Audio Dialog	4-87
Snap Shot Screen	4-87
Time Dialog	4-88
Date Dialog	4-89
Speed Dialog	4-90
Drives Submenu	4-90
Status Change Submenu	4-91
Initialize Dialog	4-91
Activate Dialog	4-92
Vary Off Dialog	4-93
Vary On Dialog	4-94
Operations Submenu	4-95
Update Microcode Dialog	4-95
Clean Drives Dialog	4-97
Unload Drives Dialog	4-99
Dismount Drives Dialog	4-100
Towers Submenu	4-102
Status Change Dialog	4-102
Initialize Dialog	4-104
Service Menu	4-105
Start Dialog	4-105
Diags Submenu	4-107
Accessor Submenu	4-108
Move Dialog	4-108
Step	4-109
Trace	4-110
Gripper Submenu	4-111
Get/Put Storage Dialog	4-111
Get/Put Drives Dialog	4-114
Step Dialog	4-116
Test Dialog	4-116
Scanner Submenu	4-117
Verify Dialog	4-117
Trigger Dialog	4-118
Fiducial Test Dialog	4-118
Tower Submenu	4-119
Home Dialog	4-119
Step Dialog	4-121
DI/DO Submenu	4-122
Loopback Dialog	4-122
Sensors Submenu	4-124
Wrap Dialog	4-124
Real Time	4-125
Locks Dialog	4-129
Self Test Dialog	4-129
P/S Submenu	4-130
Library Power	4-131
UDS Power	4-131
Library Submenu	4-132

Storage Move.....	4-133
Corner Moves	4-134
Teach Submenu	4-135
New Dialog	4-135
Continue Dialog	4-136
Current Dialog	4-137
Bays Dialog	4-140
Drive Dialog	4-141
Gripper Dialog	4-143
Tape Dialog	4-144
SAC Dialog	4-145
Demo Dialog	4-146
Verify Submenu	4-148
All Dialog	4-148
Report Dialog	4-149
Advanced Submenu	4-149
About Screen	4-150

Overview

This chapter describes the Scalar 10K operator panel menus and commands.

 **Note**
The information menus are not dynamically updated. To view changes, reselect the menu that was changed.

The operator panel is a menu-driven interface that provides library status and current operating parameters to the Scalar 10K Library.





Through the operator panel you can select, view, or change many library parameters. For a complete list of the operator panel menu items, see Figure 4-1 on page 4-8.

Using the Operator Panel

Use the operator panel push-buttons to access each menu or menu option. All menus and their respective options are grouped according to function.

Operator Panel Buttons









Proceed as follows to use the operator panel menu buttons to select menu options:

- Step 1** Press the  (Up arrow) button or the  (Down arrow) button to scroll through the current selection, or to move the cursor to a new option.
- Step 2** Press the  (Enter) button to activate your selection.
- Step 3** Press the  (Escape) button to return to the previous option.

Each time you press the Escape button, you move back one step in the menu. If you continue to press Escape, you return to the Main Menu.

Special Characters or Cursors

A menu option can be preceded or followed by one or more of the following special characters or cursors:

- ▶ When this character follows the option, additional menus are available under the selected option.
- ... When these characters follow the option, additional options or status displays are presented after the selected option.
- > When this cursor precedes the option, the option is available for selection. Press the  button to select the option. Press the  button to view information about the option. Press the  or  button to select between the previous or next options.
- < When this cursor follows the option, you can scroll predefined values with the  and  buttons for the selected option.
- ^ When this cursor appears below the option, you can scroll predefined values with the  and  buttons for the selected option.

Refer to *Using the Operator Panel* on page 3-3 for detailed information.



Help Button

Help is common to all menus, submenus, dialogs, and screens. Using Help while the cursor (< or >) is at a desired location provides information about that entry.

To use Help proceed as follows:

Step 1 Press the  (Help) button to view help on a menu selection.

The help text appears for the current selection.

Step 2 Press the  (Up arrow) button or the  (down arrow) button to move the cursor to a menu selection.

Step 3 Press the  (Escape) button to return to the previous selection.

Each time you press the Escape button, you move back one step in the menu. If you continue to press Escape, you return to the Main Menu.

Operator Intervention Message

If an error condition causes an operator intervention message to appear, refer to *Operator Intervention Messages* on page 6-4 for a complete list of messages.

Operator Panel Menu Tree Structure

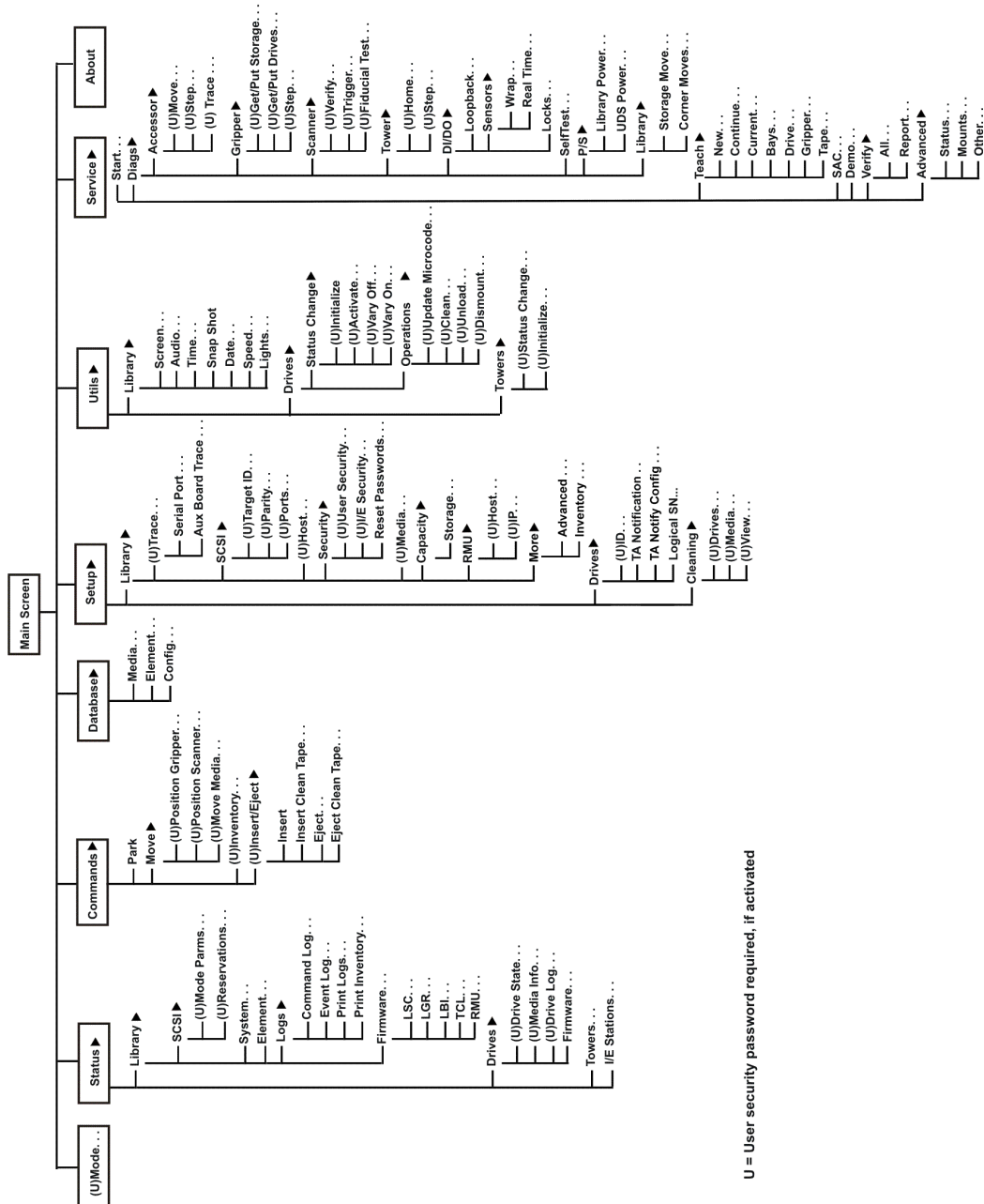

U = User security password required, if activated

Figure 4-1 Operator Panel Menu Tree Structure

Main Menu

Note

The  button can always be used to escape to the previous menu.

Path: Main Menu

The Main Menu is the first available menu after the Main Menu displays. Refer to *Starting the Scalar 10K* on page 3-7 for information about the Main Menu. All subsequent menus and options are selectable from the Main Menu. See Figure 4-2.

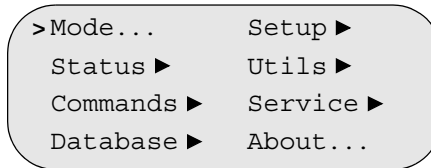

Figure 4-2 Main Menu

Mode Dialog

Path: **Main Menu ▶ Mode Dialog**

Use the Mode Dialog to change the library operating mode and/or state. For example, you can set the library to Online or Offline. See Figure 4-3.

```
Online .....Ready
>Online
Ready
Accept: N
```

Figure 4-3 Mode Dialog

Depending on your selection, one of the following appears (Ready Screen, NotReady Screen, or Shutdown Screen).



Warning

Look into the aisle to make sure there are no obstructions or personnel present prior to selecting the Ready state. Movements of mechanical components in the library can cause serious injury.



Note

If Shutdown is selected for the Mode parameter, Shutdown is automatically displayed for the State parameter.

Parameters	Description
Mode	Online - host accessible Offline - maintenance or administrator accessible only Shutdown - prepares the library for shutdown
State	Ready - accessor is available for use NotReady - accessor is not available
Accept	Y to accept changes N to reject changes

When Ready is selected, the Ready Screen appears. See Figure 4-4.

```
Changing state to:
>READY<
```

Figure 4-4 Ready Screen

When the library is in the Ready state for the first time after the library is powered on, the gripper goes through a sequence of moves in the reach axis. The sequence is as follows: ten fast moves back and forth to heat up the motor to a stable temperature followed by various back and forth moves that gradually increase in speed.

When NotReady is selected, the NotReady Screen appears. See Figure 4-5.

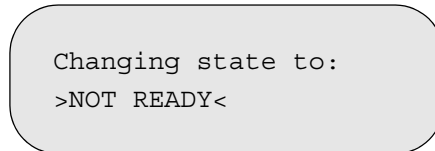

Figure 4-5 Not Ready Screen

When Shutdown is selected, the Shutdown Screen appears. See Figure 4-6.

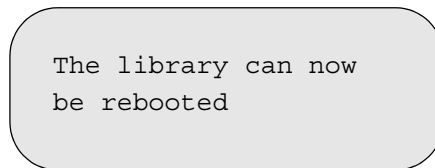

Figure 4-6 Shutdown Screen

Table 4-1 details the state and mode descriptions available under the Mode screen.

Table 4-1 Operating State and Mode

State	Mode	Description
Ready	Online	The normal host controlling condition. Host commands are processed. Aisle power is present.
	Offline	The normal operator controlling condition. Operator commands are processed. Most host commands are not processed. Aisle power is present.
NotReady	Online	Host commands not involving the accessor are processed. Aisle power is present.
	Offline	Most operator and host commands are not processed. Aisle power is present.
Shutdown	Shutdown	Allows the operator to properly shutdown the library. All commands issued by the host are completed and no other commands are accepted. Aisle power is not present.

Status Menu

Path: **Main Menu ▶ Status**

Use the Status Menu to access views of your library operating statistics. See Figure 4-7.

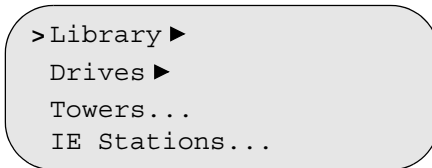

Figure 4-7 Status Menu

Depending on your selection, refer to:

- *Library Submenu* on page 4-12
- *Drives Submenu* on page 4-30
- *Towers Submenu* on page 4-38
- *IE Stations Dialog* on page 4-39

Library Submenu

Path: **Main Menu ▶ Status ▶ Library**

Use the Library Submenu to access SCSI, System, Element, Log files for viewing history or print, and Firmware information. See Figure 4-8. The Library Submenu defaults to the SCSI selection.

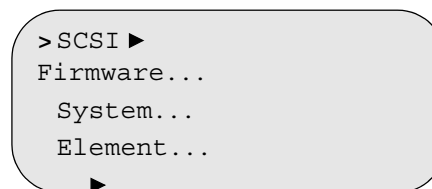

Figure 4-8 Library Submenu

Depending on your selection, refer to:

- *SCSI Submenu* below
- *System Dialog* on page 4-21
- *Element Dialog* on page 4-22
- *Logs Submenu* on page 4-25
- *Firmware Submenu* on page 4-29

SCSI Submenu

Path: **Main Menu** ► **Status** ► **Library** ► **SCSI**

Use the SCSI Submenu to view different SCSI parameters. See Figure 4-9.

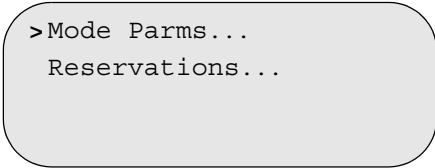

```
>Mode Parm...
Reservations...
```

Figure 4-9 SCSI Submenu

Depending on your selection, refer to:

- *Mode Parm Dialog* on page 4-13
- *Reservations Dialog* on page 4-19

Mode Parm Dialog

Path: **Main Menu** ► **Status** ► **Library** ► **SCSI** ► **Mode Parm**

Use Mode Parm to view the current, default, or saved Mode Parameter pages. For example, you can view an individual element address or see if the library has Mixed-Media Support enabled.

When Mode Parm is selected, the Mode Parm Dialog is displayed. See Figure 4-10. Refer to the *Scalar 10K SCSI Reference Manual* for additional information about the Scalar 10K Mode Parameters.

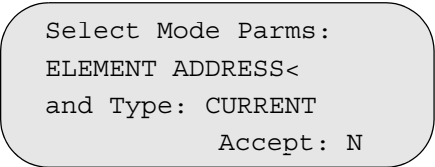

```
Select Mode Parm:
ELEMENT ADDRESS<
and Type: CURRENT
Accept: N
```

Figure 4-10 Mode Parm Dialog

Parameters	Description
Mode Parm	Element Address Mixed-Media Support Parity LCD
Type	Current - selected parameter Default - factory setting Saved - selected and saved to memory

Accept **Y** to accept changes
 N to reject changes

*If Y is selected, one of twelve response screens appears.
Otherwise, the changed parameters continue to display
but no action is taken.*

Element Address

Use Element Address to check current, default, or saved addresses of the accessor, storage cell, I/E station, or tape drives. See Figure 4-11.

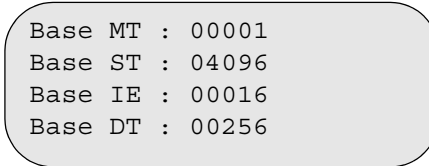

```
Base MT : 00001
Base ST : 04096
Base IE : 00016
Base DT : 00256
```

Figure 4-11 Element Address Screen

Parameter	Description
Base MT	Current, default, or saved base accessor address
Base ST	Current, default, or saved base Storage Cell address
Base IE	Current, default, or saved base Insert/Eject station address
Base DT	Current, default, or saved base tape drive address

Mixed-Media Support

Use Mixed-Media Support to determine the following.
See Figure 4-12.

- If the library is processing barcode media identifiers (Media ID)
- If the extended read element status is enabled (Ext RES)
- If vendor unique additional sense code qualifiers are currently enabled (Ext ASCQ)
- If extended barcode is enabled (Ext BC)
- If mixed mode is enabled (Mixed)

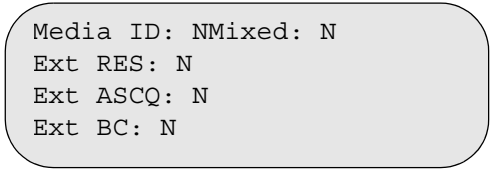

```
Media ID: N  
Mixed: N  
Ext RES: N  
Ext ASCQ: N  
Ext BC: N
```

Figure 4-12 Mixed-Media Screen

 **Note**
 When the library is not operating in mixed-media mode, the Extended RES, Extended ASCQ, and Extended BC are not applicable.

Parameter	Description
Media ID	<p>Yes indicates that the library is processing barcode media identifiers</p> <p>No indicates that the library is not processing barcode media identifiers.</p>
Ext RES	<p>Yes indicates that Extended Read Element Status is enabled to show element and media domains/types</p> <p>No indicates that Extended Read Element Status is disabled</p>
Ext ASCQ	<p>Yes indicates that Vendor Unique Additional Sense Code Qualifiers are currently enabled</p> <p>No indicates that Vendor Unique Additional Sense Qualifiers are currently disabled</p>
Ext BC	<p>Yes indicates that reported barcode includes the media type identifier</p> <p>No indicates that reported barcode does not include the media type identifier</p>
Mixed	<p>Yes indicates that the library is operating in mixed mode and allows for non-installed devices which are addressable by the SCSI host</p> <p>No indicates that the library is not operating in mixed mode and all non-installed devices/cells are not addressable by the SCSI host</p>

 **Note**
 For Dual Aisle systems, mixed mode is automatically enabled and cannot be changed.

Parity

Use Parity to view the current, default, or saved parity. This view also displays the retries that are allowed in each selection. See Figure 4-13.

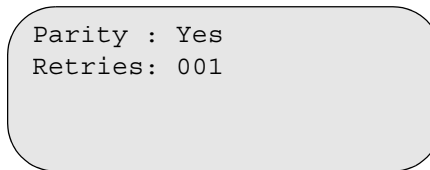

Figure 4-13 Parity Screen

Parameters	Description
Parity	Yes indicates that current, default, or saved SCSI parity is enabled No indicates that current, default, or saved SCSI parity is disabled
Retries	Indicates the number of transmission retries allowed (000–999) due to SCSI parity errors

LCD

Use LCD to view current, default, or saved library security.
See Figure 4-14.

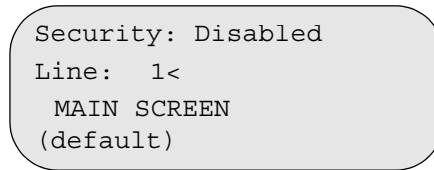





Figure 4-14 LCD Screen

 **Note**
Press the  button or the  button to toggle between the line number parameter values.

Parameter	Description
Security	Disabled indicates that LCD security is disabled Enabled indicates that LCD security is enabled
Line	Indicates the current, default, or saved displayed text line (1-4)
Text	Corresponding line of main screen text with up to 20 characters
default	Indicates which of the 3 modes (current, default, or saved) is being displayed

Reservations Dialog

Path: **Main Menu ▶ Status ▶ Library ▶ SCSI ▶ Reservations**

Use the Reservations Dialog to view a specific element, or the entire library. See Figure 4-15.

This reservation remains in effect until:

- The initiator that made the reservation sends another command with the same Reservation Identification number (this supersedes any previous reservation).
- The initiator that made the reservation sends a **RELEASE** command.
- A reset, or a power-on of the library is preformed.

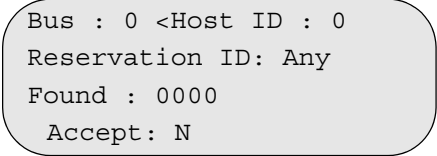

```
Bus : 0 <Host ID : 0
Reservation ID: Any
Found : 0000
Accept: N
```

Figure 4-15 Reservation Dialog

Parameters	Description
Bus	Displays the SCSI Bus ID number (0–1)
Host ID	Displays the Host ID number (0–7)
Reservation ID	Displays the host’s reservation identifier (0x00–0xFF, Any)
Found	The value of the Found parameter in the Reservation Dialog is supplied by the library firmware and cannot be changed
Accept	Y accept changes N reject changes

If Y is selected, the Response Screen appears. See Figure 4-16 on page 4-20. Otherwise, the selected parameters continue to display but no action is taken.

```
Bus: 0 <Host ID : 0
Reservation ID: Any
Found : 0109
Accept : N
```

Figure 4-16 Reservation Response Screen

Parameters	Description
Found	Indicates the number of reserved elements which match the Bus, Host ID, and Reservation ID parameters
Accept	Y to accept N to reject

System Dialog

Path: **Main Menu ▶ Status ▶ Library ▶ System**

Use the System Dialog to view the library operating statistics.

For example, the number of installed cartridges, number of free cells, or the number of gets performed by the library. See Figure 4-17.

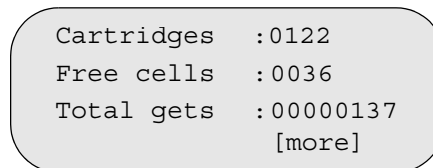

```
Cartridges :0122
Free cells :0036
Total gets :00000137
[more]
```

Figure 4-17 System Dialog

Parameters	Description
Cartridges	Displays the number of cartridges in the library
Free cells	Displays the number of free cells in the library
Total gets	The total number of gets from elements performed by the library
[more]	More information on the Continuation Screen

When [more] is selected the Continuation Screen appears. See Figure 4-18 on page 4-21.

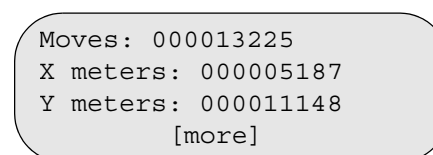

```
Moves: 000013225
X meters: 000005187
Y meters: 000011148
[more]
```

Figure 4-18 Continuation Screen

Parameters	Description
Moves	Total move media commands that have been executed
X meters	Total meters traveled by the accessor in the horizontal direction

Y meters	Total meters traveled by the accessor in the vertical direction
[more]	More information on the Continuation Screen

When [more] is selected the Continuation Screen appears. See Figure 4-19.

```
Get retries: 000008
Put retries: 000010
Scan Retries: 000009
I/E Closes: 000050
```

Figure 4-19 Continuation Screen

Parameters	Description
Get retries	Total recovered get operations
Put retries	Total recovered put operations
Scan retries	Total recovered barcode scan operations
I/E Closes	Total times the I/E station has been closed

Element Dialog

Path: Main Menu ► Status ► Library ► Element

Use the Element Dialog to display the barcode and source of a cartridge at an element address. See Figure 4-20.

```
Enter Desired
Coord: S< 01 1 A 01
Index : 00000
Accept: N
```

Figure 4-20 Element Dialog

Parameters	Description
Coord	<p>The first field indicates the type of cell (I for I/E Station, D for Drive, S for Storage cell)</p> <p>The second field indicates the rack number (01–16)</p> <p>The third field indicates the storage cell section (1–5)</p> <p>The fourth field indicates the column of the section (A–P)</p> <p>The fifth field indicates the row of the column (01–15)</p>
Index	<p>The device address associated with the selected coordinate parameter:</p> <p>DT = data transfer device IE = insert/eject device ST = storage device</p>
Accept	<p>Y to accept N to reject</p>

If Y is selected, the Response Dialog appears. See Figure 4-21 on page 4-23. Otherwise, the changed parameters continue to display but no action is taken.

```
Status: Full
BC : 010116
Source: 0000
Valid : Yes [more]
```

Figure 4-21 Response Dialog

Parameters	Description
Status	<p>Full indicates that a cartridge is present in the element</p> <p>Empty indicates that the cartridge is not present in the element</p>
BC	<p>Indicates the barcode label as found on the cartridge when the Status indicates Full</p>

Source	Indicates the original location from which this cartridge came
Valid	Yes indicates that the results shown are based on an inventory of the elements No indicates that the results shown are not based on an inventory of the elements
[more]	More information on the Continuation Screen

When [more] is selected the Continuation Screen appears. See Figure 4-22.

```
Total Puts : 0000011
Put Retries: 0000000
Get Retries: 0000000
           [more]
```

Figure 4-22 Continuation Screen

Parameters	Description
Total Puts	Indicates the total number of puts that occurred at the element
Put Retries	Indicates the total number of put retries that occurred at this element
Get Retries	Indicates the total number of get retries that occurred at this element
[more]	More information on the Continuation Screen

When [more] is selected the Continuation Screen appears. See Figure 4-23.

```
Reserved :No
Reserve ID : N/A
Reserved by: N/A
```

Figure 4-23 Continuation Screen

 **Note**
When not reserved, Reserve ID and Reserved by parameters are not applicable.

Parameters	Description
Reserved	Yes indicates the element is reserved by a SCSI host No indicates the element is not reserved
Reserve ID	Indicates the reserve ID of the element
Reserved by	Indicates the ID of the reserving host

Logs Submenu

Path: **Main Menu** ► **Status** ► **Library** ► **Logs**

Use the Logs Submenu to view command or error log history, or to print out the history logs. See Figure 4-24.

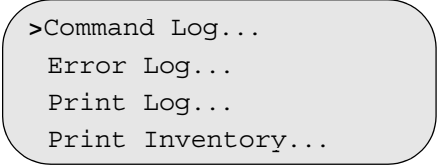

```
>Command Log...
Error Log...
Print Log...
Print Inventory...
```

Figure 4-24 Logs Submenu

Depending on your selection, one of the following dialogs appears:

- *Command Log Dialog* below
- *Error Log Dialog* on page 4-26
- *Print Log Dialog* on page 4-27
- *Print Inventory Dialog* on page 4-28

Command Log Dialog

Path: Main Menu ► Status ► Library ► Logs ► Command Log

Use the Command Log Dialog to view a running history log of library operations. A service representative retrieves this data for problem analysis. See Figure 4-25.

```
11/10/99      18:25:24.88
SCSIDONE INQ : Status
good
```

Figure 4-25 Command Log Dialog

Error Log Dialog

Path: Main Menu ► Status ► Library ► Logs ► Error Log

Use the Error Log Dialog to view a running history of events that have occurred. See Figure 4-26.

```
02/19/97      18:25:24.88
Type:  SW Temp
Error:  0X02040000
Modifier:0X00000000
```

Figure 4-26 Error Log Dialog

Parameters	Description
Type	Indicates the type of error. Record the error type in <i>Error Log Form</i> on page 6-41.
Error	Indicates the error identifier. Record the error identifier in <i>Error Log Form</i> on page 6-41.
Modifier	Indicates the error modifier. Record the error modifier in <i>Error Log Form</i> on page 6-41.

Print Log Dialog

Path: **Main Menu ▶ Status ▶ Library ▶ Logs ▶ Print Log**

Before selecting this option, make sure to connect a serial cable between the top LSC port and the laptop serial port.

When the Print Log Dialog is selected, the Print Log Screen is displayed. See Figure 4-27.

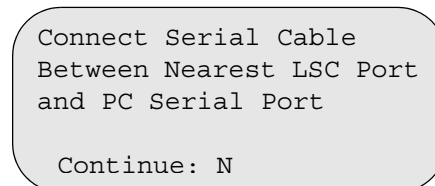

Connect Serial Cable
Between Nearest LSC Port
and PC Serial Port

Continue: N

Figure 4-27 Print Log Screen

*If Y is selected for the Continue parameter value, the Response Screen appears.
See Figure 4-28 on page 4-27. Otherwise, the changed parameter continues to display but no action is taken.*

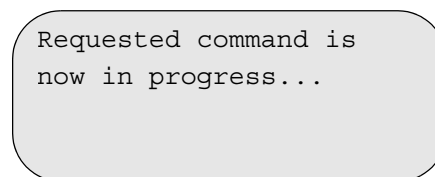

Requested command is
now in progress...

Figure 4-28 Response Screen

Print Inventory Dialog

Path: **Main Menu ▶ Status ▶ Library ▶ Logs ▶ Print Inventory**

 **Note**
If the library Trace value is set to Serial, the library also prints the tape cartridge count and inventory to the log.

Use the Print Inventory Dialog to print the library tape cartridge count and inventory to the serial port. Before selecting this option, make sure to connect a serial cable between the top LSC port and the laptop serial port.

When Print Inventory is selected, the Print Inventory screen is displayed. See Figure 4-29.

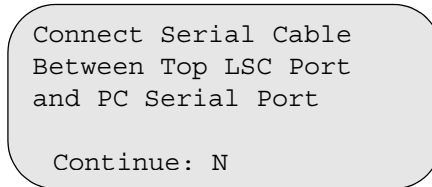

```
Connect Serial Cable
Between Top LSC Port
and PC Serial Port

Continue: N
```

Figure 4-29 Print Inventory Screen

If Y is selected for the Continue parameter value, the Response Screen appears. See Figure 4-30. Otherwise, the changed parameter continues to display but no action is taken.

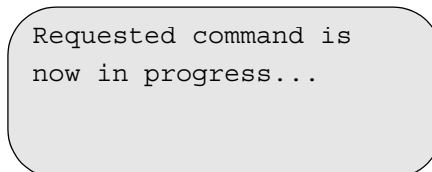

```
Requested command is
now in progress...
```

Figure 4-30 Response Screen

Firmware Submenu

Path: **Main Menu ▶ Status ▶ Library ▶ Firmware**

Use Firmware Submenu to view the library controller, boot or control firmware revisions. See Figure 4-31.

```
LBI FIRMWARE...<
RACK:04
BOOT:110A.00001
Ctrl:130A.00004
```

Figure 4-31 Firmware Submenu



Note

When LSC displays,
Rack is not reported.

Parameters	Description
FIRMWARE	This toggles between the firmware types: LSC - Library SCSI Controller LGR - Library Gripper Controller LBI - Library Box Interface TCL - Tower Controller RMU - Remote Management Unit
RACK	Indicates the corresponding rack number
BOOT	Indicates the corresponding boot code level
Ctrl	Indicates the corresponding application code level

Drives Submenu

Path: **Main Menu ▶ Status ▶ Drives**

Use the Drives Submenu to view drive, media, or firmware information. See Figure 4-32.

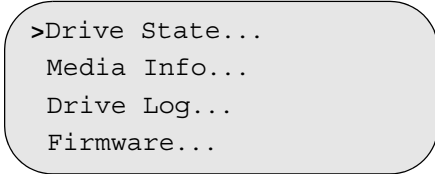

```
>Drive State...  
Media Info...  
Drive Log...  
Firmware...
```

Figure 4-32 Drives Submenu

Depending on your selection, refer to:

- *Drive State Dialog* below
- *Media Info Dialog* on page 4-35
- *Drive Log Dialog* on page 4-36
- *Firmware Dialog* on page 4-37

Drive State Dialog

Path: **Main Menu ▶ Status ▶ Drives ▶ Drive State**

Use the Drive State Dialog to view the current state of the selected drive. See Figure 4-33.

Note: If you change any drive settings, you must Vary Off and Vary On the drive to apply the new settings.

```
Enter SOURCE
Coord: D< 01 1 A 01
Index :DT 00001
Accept: N
```

Figure 4-33 Drive State Dialog

Parameters	Description
Coord	The first field indicates the type of cell (D for Drive) The second field indicates the rack number (01–16) The third field indicates the drive bay section (1–4) The fourth field indicates the column of the section (A–B) The fifth field indicates the row of the column (01–6)
Index	Indicates the number corresponding with the coordinate parameter
Accept	Y to accept N to reject

When accepted, the following screen appears. See Figure 4-34.

```
Drive: DT 00001<
State: Loaded
Clean Required: No
[more]
```

Figure 4-34 Drive State Continuation Dialog

Parameters	Description
Drive	Displays the element address of the desired drive
State	Displays the state of the drive (UNINSTALLED, VARIED OFF, NO RESPONSE, UNKNOWN, OFFLINE, DRIVE ERROR, LOADED, LOADED, UNLOADED, LOADING, UNLOADING, REWINDING, SEEKING, READING, WRITING, ERASING, CLEANING, CALIBRATING, EMPTY)
Clean Required	Indicates if the drive requires cleaning (Yes, No)
[more]	More information on the Continuation Screen

When [more] is selected and you are using SCSI drives, Figure 4-35 appears. For SCSI drive users, this is the last screen for Drive State Dialog.

 **Note**

For 3590 tape drives, the Ser #, LSN, ID, and LED fields do not display information.

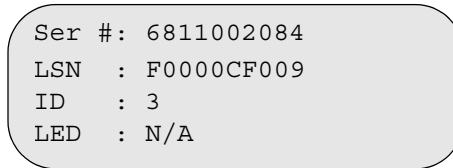



Figure 4-35 SCSI Drive Screen

When [more] is selected and you are using fibre channel drives, Figure 4-36 appears.

 **Note**

For 3592-J1A/TS1120 drives, the serial number on this screen is library-specific and for Quantum use only. This number is different from the number physically located on the 3592-J1A/TS1120 drive, which is an IBM-specific serial number.

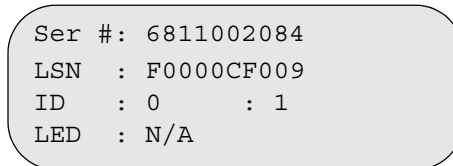

Figure 4-36 Fibre Channel Drive Screen (Dual Port)

Parameters	Description
Ser Num	Displays the drive serial number For LTO only: The last six digits 3592-J1A/TS1120 on the operator panel should match the last six digits of the serial number on the drive label. The first four digits are vendor specific and may not match.
LSN	Displays the logical serial number. The logical serial number is the last 9 digits of the world wide name assigned to the drive slot, preceded by the character "F".
ID	Displays the current SCSI/loop ID of the drive. If the fibre channel drive has dual ports, a second ID field appears.
LED	Displays the error code listed on the front panel of the drive.
[more]	More information on the Continuation Screen (for fibre channel drive only).

When [more] is selected, the Continuation Screen appears. See Figure 4-37.

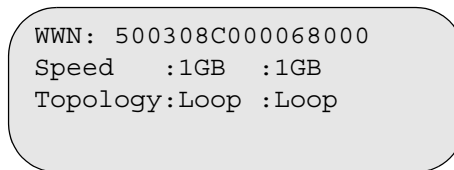



Figure 4-37 Fibre Channel Continuation Screen (Dual Port)

Parameters	Description
WWN	<p data-bbox="1000 254 1382 310">Displays the current drive world wide name.</p> <p data-bbox="1000 348 1382 499">Each drive has a unique WWN based on the library ID number and the drive position, not the manufacturer assigned drive WWN.</p> <p data-bbox="1000 537 1382 657">If you replace a fibre channel drive in the same position of the same library, the WWN remains the same.</p>
Speed	<p data-bbox="1000 682 1382 707">Data rate (Auto, 1 GB, 2 GB)</p> <p data-bbox="1000 732 1382 789">Auto: The library auto negotiates the data transfer rate.</p> <p data-bbox="1000 793 1235 819">1 GB: 1 Gigabit/sec</p> <p data-bbox="1000 823 1235 848">2 GB: 2 Gigabit/sec</p> <p data-bbox="1000 852 1235 877">4 GB: 4 Gigabit/sec</p> <p data-bbox="1000 882 1382 982">If the fibre channel drive has dual ports, a second Speed field appears.</p>
Topology	<p data-bbox="1000 993 1382 1119">Method of connecting to fibre (Auto, Loop, Nport). If the fibre channel drive has dual ports, a second Topology field appears.</p>

Media Info Dialog

Path: Main Menu ► Status ► Drives ► Media Info

 **Note**
Library must be
Offline.

Use the Media Info Dialog to display media information in loaded drive elements. See Figure 4-38.

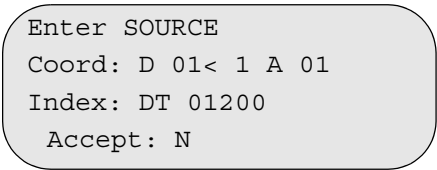

```
Enter SOURCE
Coord: D 01< 1 A 01
Index: DT 01200
Accept: N
```

Figure 4-38 Element Dialog

Parameters	Description
Coord	The first field displays the type of cell (D for drive) The second field displays the rack number (01–16) The third field displays the storage cell section (1–5) The fourth field displays the column of the section (A–B) The fifth field displays the row of the column (01–6)
Index	The device address associated with the selected coordinate parameter is DT = data transfer device
Accept	Y to accept N to reject

If Y is selected, the Response Screen appears. See Figure 4-39 on page 4-35. Otherwise, the changed parameters continue to display but no action is taken.

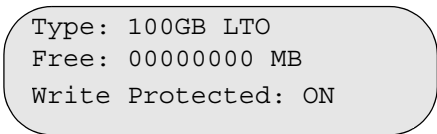

```
Type: 100GB LTO
Free: 00000000 MB
Write Protected: ON
```

Figure 4-39 Response Screen

Parameters	Description
Type	Indicates the type of media
Free	Indicates the amount of free space in MB remaining on the media in the drive
Write Protected	On indicates that the cartridge is write protected Off indicates that the cartridge is not write protected

Drive Log Dialog

Path: Main Menu ► Status ► Drives ► Drive Log

Use the Drive Log Dialog to view drive information (type of drive and location). See Figure 4-40.

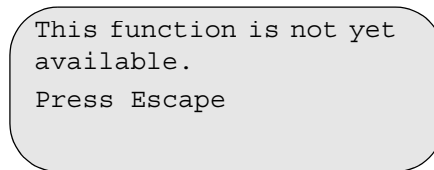

Figure 4-40 Drive Log Dialog

Firmware Dialog

Path: Main Menu ► Status ► Drives ► Firmware

Use the Firmware Submenu to view the drive and drive controller, boot or control firmware revisions. See Figure 4-41.



```
Enter Desired
Coord: D 01< 1 A 01
Index: DT 01200
Accept: N
```

Figure 4-41 Firmware Dialog

Parameters	Description
Coord	<p>The first field displays the type of cell (D for Drive)</p> <p>The second field displays the rack number (01–16)</p> <p>The third field displays the drive bay section (1–4)</p> <p>The fourth field displays the column of the section (A –B)</p> <p>The fifth field displays the row of the column (01–6)</p>
Index	The device address associated with the selected coordinate parameter DT = data transfer device
Accept	<p>Y to accept</p> <p>N to reject</p>

If Y is selected, the Response Screen appears. See Figure 4-42. Otherwise, the changed parameters continue to display but no action is taken.

Note

Press the  button or the  button to scroll between drives.

```
Drive: DT 0006<
Brick: 18N2
Boot: 120A.0002
Ctrl: 130A.0002
```

Figure 4-42 Selected Drive Firmware Revision

Towers Submenu

Path: **Main Menu ▶ Status ▶ Towers**

Use the Towers Submenu to view the tower configuration.
See Figure 4-43.

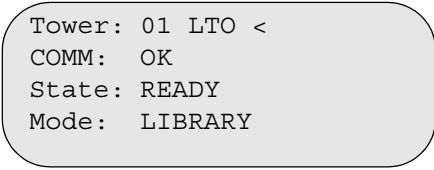

```
Tower: 01 LTO <
COMM: OK
State: READY
Mode: LIBRARY
```

Figure 4-43 Towers Submenu

Parameters	Description
Tower	Displays the tower rack number (01–16), media type of the installed towers (LTO, DLT, 8mm, HALF), and “DUAL” if the tower is shared.
COMM	Displays the communication status of the between the LSC and the tower
State	Displays the state of the tower (READY, NOT READY)
Mode	Displays the mode of the tower (LIBRARY, USER, SERVICE)

IE Stations Dialog

Path: **Main Menu ▶ Status ▶ I/E Stations**

Use the IE Stations Dialog to view the station position if a magazine is loaded and what media type it contains. See Figure 4-44.

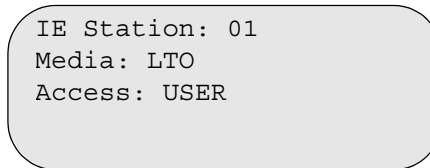

Figure 4-44 IE Stations Dialog

Parameters	Description
IE Station	Indicates the I/E Station position number (01–04)
Magazine	Indicates the type of cartridge (8mm, LTO, DLT, 1/2, or N/A if magazines are not present)
Access	Indicates library access or user access (USER, LIBRARY)

Commands Menu

Path: **Main Menu ▶ Commands**

Use the Commands Menu to access library action commands that perform a motion within the library.



Figure 4-45 Commands Menu

Depending on your selection, refer to:

- *Park* below
- *Move Submenu* on page 4-41
- *Inventory Dialog* on page 4-49
- *Insert/Eject Submenu* on page 4-51

Park

Path: **Main Menu ▶ Commands ▶ Park**

Use Park to retract the gripper and return the accessor to the home position.

If you select Park the following Response Dialogs appear. See Figure 4-46 and Figure 4-47.

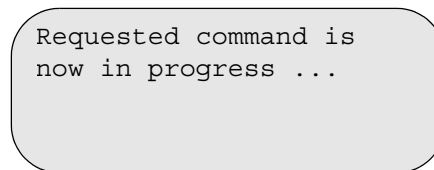

Figure 4-46 Response Dialog

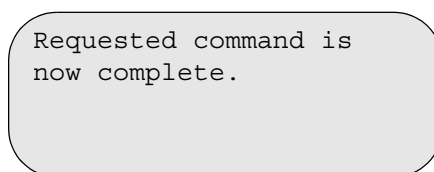



Figure 4-47 Response Dialog

Move Submenu

Path: **Main Menu ▶ Commands ▶ Move**

Use the Move Submenu to position the gripper, scanner, or to move media. See Figure 4-48.

 **Note**
The Scalar 10K must be Offline and Ready to use the commands under the Move Menu.

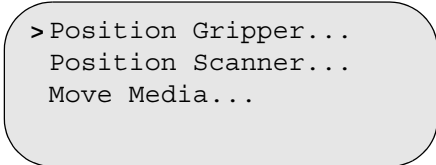

```
> Position Gripper...  
Position Scanner...  
Move Media...
```

Figure 4-48 Move Submenu

Depending on your selection, refer to:

- *Position Gripper Dialog* below
- *Position Scanner Dialog* on page 4-44
- *Move Media Dialog* on page 4-46

 **Note**
The gripper or scanner do not move to the I/E station if there are no magazines in the I/E station.

Position Gripper Dialog

Path: Main Menu ► Commands ► Move ► Position Gripper

Use the Position Gripper Dialog to move the gripper to a specific element. See Figure 4-49.

```
Enter TARGET
Coord: S< 01 1 A 01
Index: ST 00001
Accept: N
```

Figure 4-49 Position Gripper Dialog

 **Note**

The Coord: S cannot be changed to Coord: I if magazines are not installed in the I/E station.

Parameters	Description
Coord	<p>The first field indicates the type of cell (I for I/E Station, D for Drive, S for Storage cell)</p> <p>The second field indicates the rack number (01–16)</p> <p>The third field indicates the storage cell section (1–5)</p> <p>The fourth field indicates the column of the section (A–P)</p> <p>The fifth field indicates the row of the column (01–15)</p>
Index	<p>The device address associated with the selected coordinate parameter: DT = data transfer device IE = insert/eject device ST = storage device</p>
Accept	<p>Y to accept N to reject</p>

If Y is selected, two Response Screens appear. See Figure 4-50 and Figure 4-51. Otherwise, the changed parameters continue to display but no action is taken.

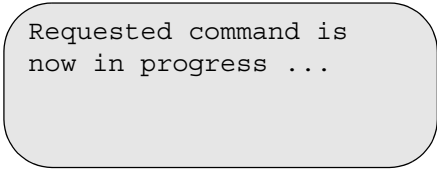

Requested command is
now in progress ...

Figure 4-50 Response Screen

The gripper positions itself in front of the specific element.

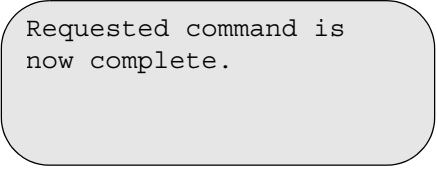

Requested command is
now complete.

Figure 4-51 Response Screen

Position Scanner Dialog

Path: Main Menu ► Commands ► Move ► Position Scanner

Use the Position Scanner to move the scanner to a specific element. See Figure 4-52.

```
Enter TARGET
Coord: S< 01 1 A 01
Index : ST 00001
Accept: N
```

Figure 4-52 Position Scanner Dialog

 **Note**

The Coord: S cannot be changed to Coord: I, if magazines are not installed in the I/E station.

Parameters	Description
Coord	The first field indicates the type of cell (I for I/E Station, D for Drive, S for Storage cell) The second field indicates the rack number (01–16) The third field indicates the storage cell section (1– 5) The fourth field indicates the column of the section (A–P) The fifth field indicates the row of the column (01–15)
Index	The device address associated with the selected coordinate parameter: DT = data transfer device IE = insert/eject device ST = storage device
Accept	Y to accept N to reject

If Y is selected, two Response Screens appear. See Figure 4-53 on page 4-45 and Figure 4-54 on page 4-45. Otherwise, the changed parameters continue to display but no action is taken.

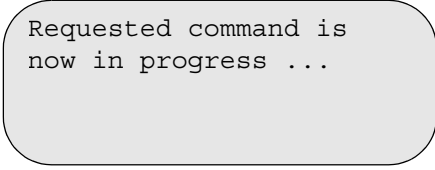

Requested command is
now in progress ...

Figure 4-53 Response Screen

The scanner positions itself in front of the specific element.

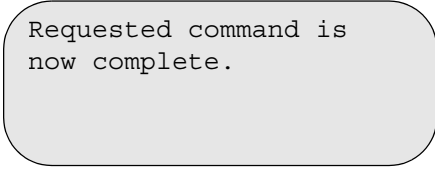

Requested command is
now complete.

Figure 4-54 Response Screen

Move Media Dialog

Path: **Main Menu ▶ Commands ▶ Move ▶ Move Media**

Use the Move Media Dialog to move cartridges between elements without host intervention. See Figure 4-55.



If your library is host partitioned or a COD configuration, do not use the operator panel to move a cartridge. The library does not know the partition limits and could move a cartridge outside of the partitioned area, making that cartridge inaccessible to the host.

```
Enter SOURCE
Coord: S< 01 1 A 01
Index: ST 00001
Accept : N
```

Figure 4-55 Move Media Dialog

Parameters	Description
Coord	<p>The first field indicates the type of cell (I for I/E Station, D for Drive, S for Storage cell)</p> <p>The second field indicates the rack number (01–16)</p> <p>The third field indicates the storage cell section (1–5)</p> <p>The fourth field indicates the column of the section (A–P)</p> <p>The fifth field indicates the row of the column (01–15)</p>
Index	<p>The device address associated with the selected coordinate parameter: DT = data transfer device IE = insert/eject device ST = storage device</p>
Accept	<p>Y to accept N to reject</p>

If Y is selected, the Target Dialog appears. See Figure 4-56. Otherwise, the changed parameters continue to display but no action is taken.

```

Enter TARGET
Coord: I< 01 1 A 01
Index: 15949
Accept : N
  
```

Figure 4-56 Target Dialog

Parameters	Description
Coord	<p>The first field indicates the type of cell (I for I/E Station, D for Drive, S for Storage cell)</p> <p>The second field indicates the rack number (01–16)</p> <p>The third field indicates the storage cell section (1– 5)</p>

	The fourth field indicates the column of the section (A-P)
	The fifth field indicates the row of the column (01-15)
Index	The device address associated with the selected coordinate parameter: DT = data transfer device IE = insert/eject device ST = storage device
Accept	Y to accept N to reject

If Y is selected, the Response Screens appear. See Figure 4-57 and Figure 4-58. Otherwise, the changed parameters continue to display but no action is taken

```
Requested command is
now in progress ...
```

Figure 4-57 Response Screen

The accessor moves the cartridge from the selected Source, to the selected Target element.

```
Requested command is
now complete.
```

Figure 4-58 Response Screen

If an empty source element is selected, the Error Screen appears. See Figure 4-59.

```
--> ERROR <--
The Source element
is empty.
```

Figure 4-59 Error Screen

If a target element that is already occupied by a cartridge is selected, the Error Screen appears. See Figure 4-60.

```
--> ERROR <==  
The target element  
is full.
```

Figure 4-60 Error Screen

Inventory Dialog

Path: **Main Menu ▶ Commands ▶ Inventory**

Use the Inventory Dialog to inventory specific elements.
See Figure 4-61.

```
Starting Inventory  
Coord: S 01 1< A 01  
Index: ST 00001  
Accept : N
```

Figure 4-61 Inventory Dialog

Parameters	Description
Coord	<p>The first field indicates the type of cell (I for I/E Station, D for Drive, S for Storage cell)</p> <p>The second field indicates the rack number (01–16)</p> <p>The third field indicates the storage cell section (1–5)</p> <p>The fourth field indicates the column of the section (A–P)</p> <p>The fifth field indicates the row of the column (01–15)</p>
Index	<p>The device address associated with the selected coordinate parameter: DT = data transfer device IE = insert/eject device ST = storage device</p>

Accept **Y** to accept
 N to reject

If Y is selected, the Ending Inventory Dialog appears. See Figure 4-62 on page 4-50. Otherwise, the changed parameters continue to display but no action is taken.

Ending Inventory
Coord: D< 03 2 A 01
Index: DT 00013
Accept : N

Figure 4-62 Ending Inventory Dialog

Parameters	Description
Coord	The first field indicates the type of cell (I for I/E Station, D for Drive, S for Storage cell) The second field indicates the rack number (01–16) The third field indicates the storage cell section (1– 5) The fourth field indicates the column of the section (A–P) The fifth field indicates the row of the column (01–15)
Index	The device address associated with the selected coordinate parameter: DT = data transfer device IE = insert/eject device ST = storage device
Accept	Y to accept N to reject

If Y is selected, the Response Screens appear. See Figure 4-63 and Figure 4-64 on page 4-51. Otherwise, the changed parameters continue to display but no action is taken.

```
Requested command is
now in progress ...
```

Figure 4-63 Response Screen

The barcode scanner inventories the specified storage cells.

```
Requested command is
now complete.

Found : 100
```

Figure 4-64 Response Screen

Parameter	Description
Found	Indicates the total number of cartridges detected

Insert/Eject Submenu

Path: **Main Menu ▶ Commands ▶ Insert/Eject**

Use the Insert/Eject Submenu to insert or eject a clean tape in or out of the library. See Figure 4-65.

 **Note**
Use this option to insert or eject cartridge(s) without host intervention.

```
>Insert
  Insert Clean Tape...
  Eject...
  Eject Clean Tape...
```

Figure 4-65 Insert/Eject Submenu

Depending on your selection, refer to:

- *Insert Screen* below
- *Insert Clean Tape Dialog* on page 4-53
- *Eject Dialog* on page 4-56
- *Eject Clean Tape Dialog* on page 4-58



If your library is host partitioned, do not use the operator panel to move a cartridge. The library does not know the partition limits and could move a cartridge outside of the partitioned area, making that cartridge inaccessible to the host.

Insert Screen

Path: **Main Menu ▶ Commands ▶ Insert/Eject ▶ Insert**

Use the Insert Screen to move all cartridges found in the Insert/Eject stations to the first available empty storage cells. See Figure 4-66.

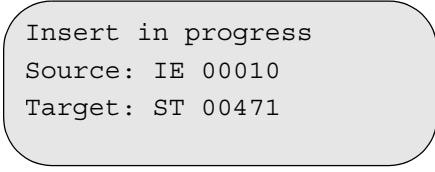

```
Insert in progress
Source: IE 00010
Target: ST 00471
```

Figure 4-66 Insert Screen

The Current Source and Target elements are updated. After completion, the response screen shows how many cartridges are in the Insert/Eject stations. See Figure 4-67 on page 4-52.

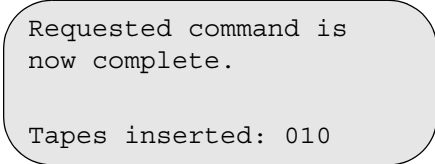

```
Requested command is
now complete.

Tapes inserted: 010
```

Figure 4-67 Response Screen

If no tapes are installed, Tapes inserted indicates 000.
If one tape is installed, Tapes inserted indicates 001.

Insert Clean Tape Dialog

Path: Main Menu ► Commands ► Insert/Eject ► Insert Clean Tape

Use the Insert Clean Tape Dialog to move the selected cleaning cartridge from the Insert/Eject station to the designated empty storage cells. See Figure 4-68.



It is possible to manually insert a cleaning tape into an unauthorized storage area. The use of Insert Clean is not recommended or intended for host initiated cleaning. If you use host initiated cleaning, the cleaning tape may not be accessible and your drives may not be cleaned.

```
Enter SOURCE
Coord: I 01< 1 A 01
Index: IE 00001
Accept: N
```

Figure 4-68 Insert Clean Tape Dialog

Parameters	Description
Coord	The first field indicates the type of cell (I for I/E Station, D for Drive, S for Storage cell) The second field indicates the rack number (01–16) The third field indicates the storage cell section (1–5) The fourth field indicates the column of the section (A–P) The fifth field indicates the row of the column (01–15)
Index	The device address associated with the selected coordinate parameter: DT = data transfer device IE = insert/eject device ST = storage device
Accept	Y to accept N to reject

If Y is selected, the Insert Range screen appears. Select the number of cleaning tapes to insert. See Figure 4-69.

```

Insert Range: 01<

Accept : N

```

Figure 4-69 Insert Range Screen

Parameters	Description
Insert Range	Indicates the number of elements for the insert operation
Accept	Y accept changes N reject changes

If Y is selected, the Target Screen appears. See Figure 4-70. Otherwise, the changed actions continue to display but no action is taken.

```

Enter TARGET
Coord: S 01 1< A 01
Index: ST 00001

Accept : N

```

Figure 4-70 Target Screen

Parameters	Description
Coord	The first field indicates the type of cell (I for I/E Station, D for Drive, S for Storage cell)
	The second field indicates the rack number (01–16)
	The third field indicates the storage cell section (1–5)
	The fourth field indicates the column of the section (A–P)
	The fifth field indicates the row of the column (01–15)

Note
The starting address is indicated by the Coordinate and index parameters. If several cleaning tapes are inserted, the Coordinate and Index is specified for the first empty cell in a group of consecutive empty cells.

Index	The device address associated with the selected coordinate parameter: DT = data transfer device IE = insert/eject device ST = storage device
Accept	Y to accept N to reject

*If **Y** is selected, the Usage Screen appears. See Figure 4-71. If **N** is selected, the changed parameters continue to display but no action is taken.*

```

CurrentUse: 000<
MaxUse: 000

Accept: N

```

Figure 4-71 Usage Screen

Parameters	Description
Current Usage	Indicates the number of times the cleaning cartridge has been used (000–511)
Maximum Usage	Indicates the maximum number of allowable uses for the cleaning cartridge (000–511)
Accept	Y accept changes N reject changes

*If **Y** is selected, the accessor moves the number of cleaning cartridges to the designated storage cells. When the operation completes, the Response Screen appears. See Figure 4-72. If **N** is selected, the changed parameters continue to display but no action is taken.*

```

Requested command is
now complete.

Tapes inserted: 001

```

Figure 4-72 Response Screen

Eject Dialog

Path: **Main Menu ▶ Commands ▶ Insert/Eject ▶ Eject**

Use the Eject Dialog to remove cartridges without opening the service or access doors, or without host intervention. The final destination is a slot in the Insert/Eject station. See Figure 4-73.



If your library is host partitioned, do not use the operator panel to move a cartridge. The library does not know the partition limits and could move a cartridge outside of the partitioned area, making that cartridge inaccessible to the host.

```
Enter SOURCE
Coord: S< 01 1 A 01
Index :ST 00001
Accept: N
```

Figure 4-73 Eject Dialog

Parameters	Description
Coord	The first field indicates the type of cell (I for I/E Station, D for Drive, S for Storage cell) The second field indicates the rack number (01–16) The third field indicates the storage cell section (1–5) The fourth field indicates the column of the section (A–P) The fifth field indicates the row of the column (01–15)
Index	Indicates the number corresponding with the coordinate parameter
Accept	Y to accept N to reject

If Y is selected, the Eject Screen appears. See Figure 4-74. Otherwise, the changed actions continue to display but no action is taken.

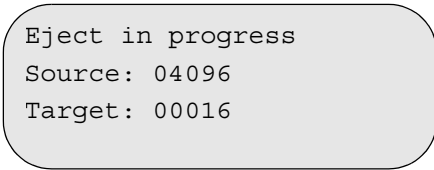

```
Eject in progress
Source: 04096
Target: 00016
```

Figure 4-74 Eject Screen

The cartridge is ejected to the first available empty cell in the Insert/Eject station. The Response Screen appears. See Figure 4-75.

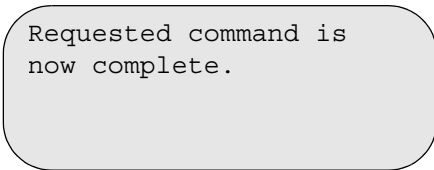

```
Requested command is
now complete.
```

Figure 4-75 Response Screen

Eject Clean Tape Dialog

Path: Main Menu ► Commands ► Insert/Eject ► Eject Clean Tape

Use the Eject Clean Tape Dialog to remove a cleaning cartridge without opening the service or access door, or without host intervention. See Figure 4-76.

```
Enter SOURCE
Coord: S 01 1< A 01
Index: ST 00001
Accept: N
```

Figure 4-76 Eject Clean Tape Dialog

Parameters	Description
Coord	The first field indicates the type of cell (I for I/E Station, D for Drive, S for Storage cell) The second field indicates the rack number (01–16) The third field indicates the storage cell section (1–5) The fourth field indicates the column of the section (A–P) The fifth field indicates the row of the column (01–15)
Index	The device address associated with the selected coordinate parameter: DT = data transfer device IE = insert/eject device ST = storage device
Accept	Y to accept N to reject

If Y is selected, the Clean Media Eject Screen appears. See Figure 4-77. Otherwise, the changed actions continue to display but no action is taken.

```
Eject in progress
Source : 00000
Target : 00788
```

Figure 4-77 Eject Clean Tape Screen

The cartridge is ejected to the first available empty cell in the Insert/Eject station. The Response Screen appears. See Figure 4-78.

```
Requested command is
now complete.
```

Figure 4-78 Response Screen

Database Menu

Path: **Main Menu ▶ Database**

Use the Database Menu to access information about the type of media, elements, or configuration of your library. See Figure 4-79.

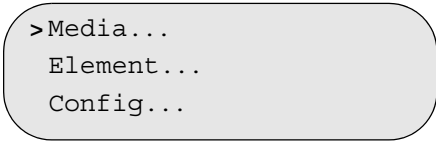

```
>Media...
Element...
Config...
```

Figure 4-79 Database Menu

Depending on your selection, refer to:

- *Media Dialog* below
- *Element Dialog* on page 4-61
- *Config Dialog* on page 4-63

Media Dialog

Note

If in extended mode, the space value (^) erases the remaining values and the wildcard value (*) is used to indicate that any volume label that includes the preceding values will be selected.

Path: **Main Menu ▶ Database ▶ Media**

Use the Media Dialog to obtain information about a specific cartridge based on the barcode label.

In default or mixed mode, six characters are required. In extended mode five characters are required. However, up to sixteen characters may be entered. Figure 4-80 shows the Media Dialog.

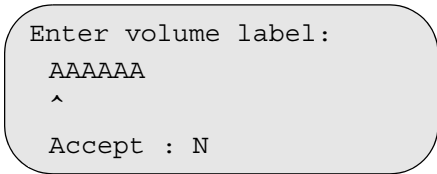

```
Enter volume label:
AAAAAA
^
Accept : N
```

Figure 4-80 Media Dialog

Parameters	Description
AAAAA	Indicates the volume label (A–Z, 0–9)
Accept	Y accept changes N reject changes

If Y is selected, the Response Screen appears. See Figure 4-81 on page 4-61. Otherwise, the changed parameters continue to display but no action is taken.

```
BC: 000389
Type: SDLT
Home: 0060
Current: 0060
```

Figure 4-81 Response Screen

Parameters	Description
BC	Indicates the value specified in the Media Screen
Type	Indicates the cartridge media type
Home	Indicates the home location of the cartridge
Current	Indicates the current location of the cartridge

Element Dialog

Path: Main Menu ► Database ► Element

Use the Element Dialog to select specific element information from the database. See Figure 4-82.

```
Enter Desired
Coord: S 01< 1 A 01
Index: ST 00001
Accept: N
```

Figure 4-82 Element Dialog

Parameters	Description
Coord	The first field indicates the type of cell (I for I/E Station, D for Drive, S for Storage cell) The second field indicates the rack number (01–16)

	The third field indicates the storage cell section (1–5)
	The fourth field indicates the column of the section (A–P)
	The fifth field indicates the row of the column (01–15)
Index	The device address associated with the selected coordinate parameter: DT = data transfer device IE = insert/eject device ST = storage device
Accept	Y to accept N to reject

If Y is selected, the Element Response Screen appears. See Figure 4-83 on page 4-62. Otherwise, the changed actions continue to display but no action is taken.

```
Type: LTO STOR
Coord: S 01 1 A 01
Index : ST 00001
Addr: 0X1000 [more]
```

Figure 4-83 Element Response Screen

Parameters	Description
Type	Indicates the element type (DRIVE, IE, STOR)
Coord	Indicates the element coordinate location
Index	Indicates the database element index
Address	Indicates the current SCSI element address

When [more] is selected the Continuation Screen appears. See Figure 4-84.

```
X position: 0091.9
Y position: 1502.1
Z position: 1097
```

Figure 4-84 Continuation Screen

Parameters	Description
X position	Indicates the horizontal coordinate in millimeters
Y position	Indicates the vertical coordinate in millimeters
Z position	Indicates the depth coordinate

Config Dialog

Path: **Main Menu ▶ Database ▶ Config**

Use the Config Dialog to view the current library configuration. See Figure 4-85.

```
Serial#: 201100001
Racks: 04
Storage Cells : 680
Drive Cells: 12
```

Figure 4-85 Config Screen

Parameters	Description
Serial	The serial number of the accessor module
Racks	The number of racks
Storage Cells	Total number of storage cells
Drive Cells	Total number of drives

Setup Menu

Path: **Main Menu ▶ Setup**

Use the Setup Menu to change the physical or logical operational characteristics of the Library. See Figure 4-86.

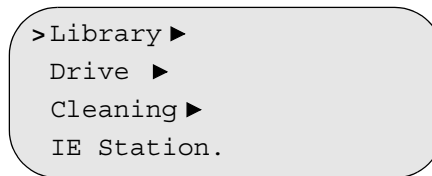

Figure 4-86 Setup Menu

Depending on your selection, refer to:

- *Library Submenu* on page 4-64
- *Drives Submenu* on page 4-87
- *Cleaning Submenu* on page 4-94
- *IE Station Submenu* on page 4-95

Library Submenu

Path: **Main Menu ▶ Setup ▶ Library**

Use the Library Submenu to change the library defaults. See Figure 4-87.

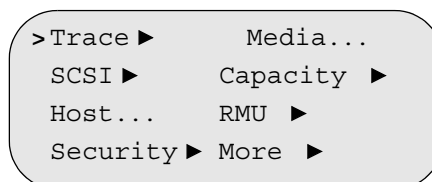

Figure 4-87 Library Submenu

Depending on your selection, refer to:

- *Trace Submenu* on page 4-65
- *SCSI Submenu* on page 4-66
- *Host Dialog* on page 4-70
- *Security Submenu* on page 4-71
- *Media Dialog* on page 4-77
- *Capacity Submenu* on page 4-79
- *RMU Submenu* on page 4-82
- *More Submenu* on page 4-84

Trace Submenu

Path: Main Menu ► Setup ► Library ► Trace

Use the Trace Submenu to define or enable the serial service port. See Figure 4-88.

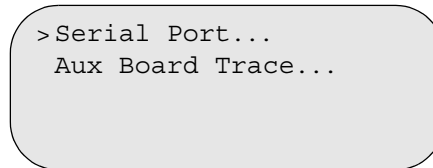

Figure 4-88 Trace Submenu

If Serial Port is selected the Serial Port Screen appears. See Figure 4-89.

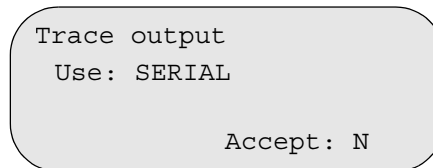



Figure 4-89 Serial Port Screen

 **Note**
If the RMU is not installed, this option must be set to SERIAL in order to prevent a SAC from being posted.

Parameters	Description
Use	SERIAL indicates information is returned via the serial port RMU is the default to allow the port to be used for RMU communication VCONSOL is used for development only
Accept	Y to accept changes N to reject changes

If Y is selected, the screen updates to reflect the changes. Otherwise, the changed parameters continue to display but no action is taken.

If Aux Board Trace is selected and Serial Port trace output is set to Serial, the Aux Board Trace Screen appears. See Figure 4-90 on page 4-66.

```

Aux Trace Reporting:
Board:All Aux
Status:Off
Accept: N

```

Figure 4-90 Aux Board Screen

Parameters	Description
Board	All Aux sets trace information for all boards LGR # displays gripper traces LBI # displays the selected LBI rack traces (# = the selected rack number)
Status	On enables trace Off disables trace
Accept	Y to accept changes N to reject changes

If Y is selected, the screen updates to reflect the changes. Otherwise, the changed parameters continue to display but no action is taken.

SCSI Submenu

Path: **Main Menu ▶ Setup ▶ Library ▶ SCSI**

Use the SCSI Submenu to set the library SCSI ID, SCSI bus type, and parity. See Figure 4-91.

```

>Target ID...
Parity...
Ports...

```

Figure 4-91 SCSI Submenu

Depending on your selection, refer to:

- *Target ID Dialog* on page 4-67
- *Parity Dialog* on page 4-68
- *Ports Dialog* on page 4-69

Target ID Dialog

Path: **Main Menu ▶ Setup ▶ Library ▶ SCSI ▶ Target ID**

 **Note**
The Scalar 10K
defaults to SCSI
ID 6.

Use the Target ID Dialog to set the library SCSI ID.
See Figure 4-92. Changes do not take effect until library power
is cycled.

Note: In Dual Aisle configurations, make sure that each aisle
(primary and secondary) has a unique SCSI ID.

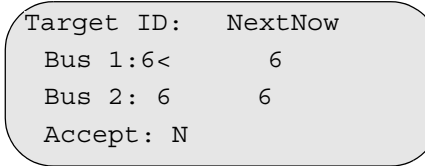

```
Target ID:  NextNow
Bus 1: 6<    6
Bus 2: 6     6
Accept: N
```

Figure 4-92 Target ID Dialog

Parameters	Description
Bus 1: Next	Next indicates the SCSI ID address that takes effect for bus port 1 after power is cycled (0-7)
Bus 1: Now	Now the SCSI ID address that is currently in effect (0-7) for bus port 1
Bus 2: Next	Next indicates the SCSI ID address that takes effect for bus port 2 after power is cycled (0-7)
Bus 2: Now	Now the SCSI ID address that is currently in effect (0-7) for bus port 2
Accept	Y to accept changes N to reject changes

*If **Y** is selected, the screen updates to reflect the changes. Otherwise, the changed parameters continue to display but no action is taken.*

Parity Dialog

Path: **Main Menu ▶ Setup ▶ Library ▶ SCSI ▶ Parity**

Use the Parity Dialog to set the SCSI bus parity. Changes do not take effect until library power is cycled. See Figure 4-93.

```
Next          Now
Parity        Yes<Yes
Retries       001001
Accept:      N
```

Figure 4-93 Parity Dialog

Parameters	Description
Parity: Next	YES to enable SCSI parity NO to disable SCSI parity
Parity: Now	YES indicates parity dialog is supplied by the library firmware NO ignores the Retries parameter
Retries: Next	Set the number of retries (000–255) allowed when a SCSI parity error is detected
Retries: Now	YES indicates parity dialog is supplied by the library firmware NO indicates the current number of retries allowed (000–255) when a SCSI parity error is detected
Accept	Y to accept changes N to reject changes

*If **Y** is selected, the screen updates to reflect the changes. Otherwise, the changed parameters continue to display but no action is taken.*

Ports Dialog

Path: **Main Menu ▶ Setup ▶ Library ▶ SCSI Submenu ▶ Ports**

Use the Ports Dialog to indicate the current SCSI bus type and usage. See Figure 4-94.

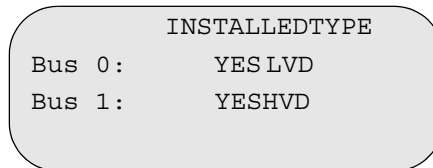

Figure 4-94 Ports Screen

Parameters	Description
Bus 0: INSTALLED	YES indicates the port is active NO indicates the port is not active
Bus 0: TYPE	HVD indicates the bus is high voltage differential LVD indicates the bus is low voltage differential SE indicates the bus is single ended
Bus 1: INSTALLED	YES indicates the port is active NO indicates the bus is not active.
Bus 1: TYPE	HVD indicates the bus is high voltage differential LVD indicates the bus is low voltage differential SE indicates the bus is single ended

Host Dialog

Path: **Main Menu ▶ Setup ▶ Library ▶ Host**

Use the Host Dialog to set the type of host control.
See Figure 4-95.

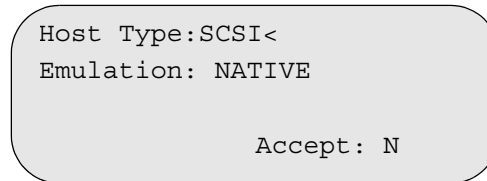

```
Host Type:SCSI<
Emulation: NATIVE

Accept: N
```

Figure 4-95 Host Dialog

 **Note**
At present, only
SCSI control is
supported.

Parameters	Description
Host type	SCSI indicates SCSI control
Emulation	Select Library Type (NATIVE, STK 9710, EXB 480, AML/S or Scalar1K)
Accept	Y to accept changes N to reject changes

If Y is selected, the screen updates to reflect the changes. Otherwise, the changed parameters continue to display but no action is taken.

Security Submenu

 **Note**
Refer to your host application documentation for security information.

Path: **Main Menu ▶ Setup ▶ Library ▶ Security**

Use the Security Submenu to change the operator panel LCD Security mode or the password that protects it. The operator panel can also be secured by the host.

The method used to secure the operator panel must be the same method used to release the security. See Figure 4-96.

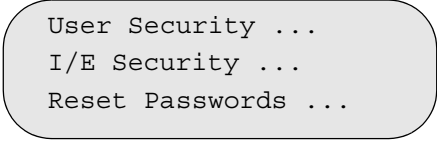

User Security ...
I/E Security ...
Reset Passwords ...

Figure 4-96 Security Submenu

Depending on your selection, refer to:

- *User Security* on page 4-72
- *I/E Security* on page 4-74
- *Reset Passwords* on page 4-76

User Security

Path: **Main Menu ▶ Setup ▶ Library ▶ Security ▶ User Security**

Use User Security to set the user security, or change the user password for the operator panel. This security feature password-protects the operator panel.

If User Security is not enabled, the Host Dialog appears. See Figure 4-97.

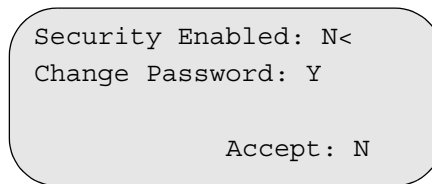

A screenshot of a Host Dialog box with a rounded rectangular border. The text inside is as follows:

```
Security Enabled: N<
Change Password: Y

Accept: N
```

Figure 4-97 Host Dialog

Parameters	Description
Security	Y to enable User security N to disable User security
Change Password	Y to change the current password N to keep the current password
Accept	Y to accept changes N to reject changes

If User Security is enabled, the Password Dialog appears. See Figure 4-98.

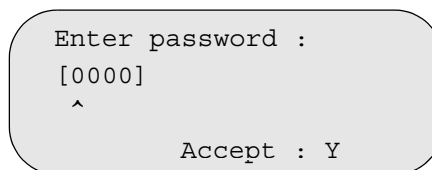

A screenshot of a Password Dialog box with a rounded rectangular border. The text inside is as follows:

```
Enter password :
[0000]
^

Accept : Y
```

Figure 4-98 Password Dialog

After you enter the correct password, the Host Dialog appears. See Figure 4-99 on page 4-73.

```
Security Enabled: N<
Change Password: Y

Accept: N
```

Figure 4-99 Host Dialog

If you enter an incorrect password, Invalid Password appears. See Figure 4-100. You must go back and enter the correct password.

```
You did not enter a
valid password.
```

Figure 4-100 Invalid Password

If you wish to change the password and if Change Password is Y, the Change Password dialog appears. See Figure 4-101.

```
Change Password:
Old[0000] New[0000]
^
Accept: N
```

Figure 4-101 Change Password Dialog

If you enter the old password and a new password, Password Changed appears. See Figure 4-102.

```
The password has
changed.
```

Figure 4-102 Password Changed Screen

I/E Security

Path: **Main Menu ▶ Setup ▶ Library ▶ Security ▶ I/E Security**

 **Note**
I/E Security may or may not have the same password as User Security.

Use I/E Security to set the I/E security or change the password for the I/E stations. This security feature password-protects all I/E stations.

If I/E Security is not enabled, I/E Security appears. See Figure 4-103.

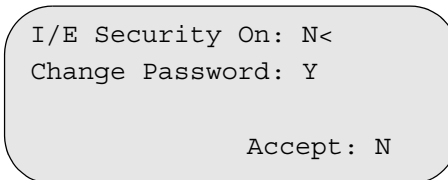

```
I/E Security On: N<
Change Password: Y

Accept: N
```

Figure 4-103 I/E Security

Parameters	Description
Security	Y to enable I/E Security N to disable I/E Security
Change Password	Y to change the current password N to keep the current password
Accept	Y to accept changes N to reject changes

If I/E Security is enabled, the Password Dialog appears. See Figure 4-104.

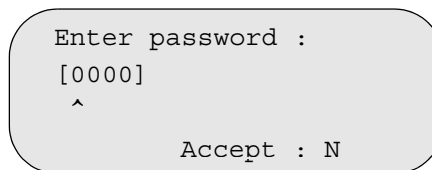

```
Enter password :
[0000]
^

Accept: N
```

Figure 4-104 Password Dialog

If you wish to change the password and if Change Password is **Y**, the Change Password dialog appears. See Figure 4-105 on page 4-75.

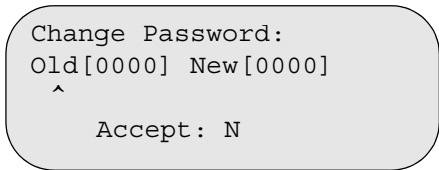

Change Password:
Old[0000] New[0000]
^
Accept: N

Figure 4-105 Change Password Dialog

Enter the old and new passwords and the Password Changed Screen appears. See Figure 4-106

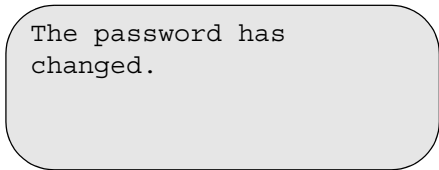

The password has
changed.

Figure 4-106 Password Changed Screen

If you disable security, the Security is Off screen appears. See Figure 4-107.

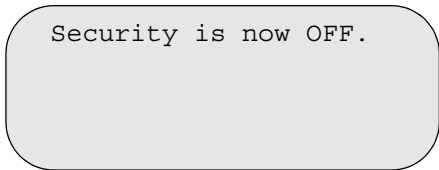

Security is now OFF.

Figure 4-107 Security is OFF Screen

If you enable security, the Security is On Screen appears. See Figure 4-108.

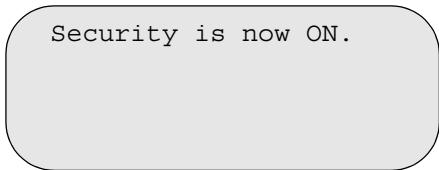

Security is now ON.

Figure 4-108 Security is ON Screen

Reset Passwords

Path: **Main Menu ▶ Setup ▶ Library ▶ Security ▶ Reset Passwords**

 **Note**
To reset passwords to default, contact GCH.

Use Reset Password to reset all passwords to factory default. See Figure 4-109.

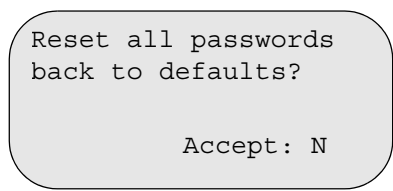



Figure 4-109 Reset Password

 **Note**
The password default is factory setting.

Parameters	Description
To Reset to default	Y to reset passwords N to leave the password as it is
Accept	Y to accept changes N to reject changes

*If **Y** is selected for the Accept parameter and the password parameter, the Reset Password Screen appears. See Figure 4-110*

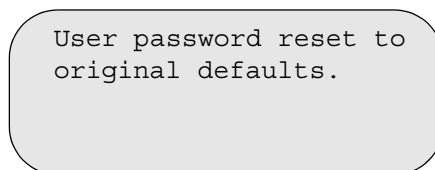

Figure 4-110 Reset Password Dialog

Media Dialog

Path: Main Menu ► Setup ► Library ► Media

Use the Media Dialog to control the settings for media handling and reporting. The host software must support device gaps if the library is operating in mixed mode. For example: uninstalled drive, cartridge, or I/E locations. See Figure 4-111.

For additional information, refer to the *Scalar 10K SCSI Reference Manual*.

```
Volser:Media ID<
ID: POSTMixed :Y
Extend: YASCQ :Y
CODE39: NAccept: N
```

Figure 4-111 Media Dialog

 **Note**

If the value of the **Media ID** parameter is changed, an inventory is required.

 **Note**

In order for a Scalar DLC to work properly in a Dual Aisle configuration, the Volser parameter must be set to **Media ID**, Mixed must be set to **Y**, Extend must be set to **Y**, and ASCQ must be set to **Y**.

 **Note**

If Media ID is not selected, Extend and ASCQ are set to **N** and ID is set to **NONE**.

Parameters

Volser

ID

Description+

MEDIA ID

Media Identifier support is enabled. The library shall scan barcode media identifiers. This mode requires the use of six-character barcodes with 1 or 2 byte media identifiers.

DEFAULT indicates that the library supports six-character barcode labels, or mixed mode labels that have an additional seventh or eighth media ID character. The barcode is stored and reported as a six-character barcode (ignoring any mixed-media IDs).

EXTENDED indicates that the library supports five to sixteen character barcode labels, which may indicate any mixed-media IDs and/or checksums.

PRE indicates that the media identifier is added to the front of the barcode label for RES and RVEA.

POST indicates that the media

	identifier is added to the end of the barcode label for RES and RVEA. NONE indicates that the media identifier is not used.
Extend	Y indicates that extended (Extend_RES) element descriptor status is enabled. Extended status is reported for RES and RVEA commands. N indicates that extended element descriptor status is disabled.
CODE39	Y indicates the library supports Code 39 labels. N indicates the library does not support Code 39 labels.
Mixed	Y presents device gaps. Device elements are reported as consecutive element addresses regardless of being installed or not. N collapses device gaps. Not installed devices are not reported, and element addresses are only assigned to installed device elements.
ASCQ	Y use Quantum-specific ASC/ASCQs. N use standard SCSI-2 ASC/ASCQs.
Accept	Y to accept changes. N to reject changes.

If Y is selected, the screen updates to reflect the changes. Otherwise, the changed parameters continue to display but no action is taken.

Capacity Submenu

Path: **Main Menu ▶ Setup ▶ Library ▶ Capacity**

Use the Capacity Submenu to view and change the authorized storage cells and drive limits for the library. See Figure 4-112.

 **Note**
Contact GCH to receive the authorization code.



Figure 4-112 Capacity Submenu

Refer to *Storage Dialog* below.

Storage Dialog

Path: **Main Menu ▶ Setup ▶ Library ▶ Capacity ▶ Storage**

Use the Storage Dialog to view the authorized storage cell limits for each media type in the library. See Figure 4-113.

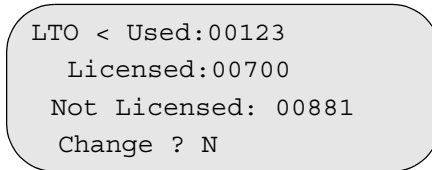

Figure 4-113 Storage Dialog

 **Note**
The library only displays installed media types when you are toggling through the list of storage types.

Parameters	Description
Media Type	Toggles through the installed media types (LTO, DLT, 8MM, Half Inch).
Used	Number of used cells in license.
Licensed	Displays the number of library storage cells that are currently accessible.
Not licensed	Displays the number of library storage cells that are not currently accessible.
Change ?	When the media type is selected for change, the library automatically displays the Enter Capacity Dialog.

Proceed as follows to view the authorized storage cell limits:

Step 1 Press Up arrow or Down arrow to toggle through the media types.

As each media type appears, the authorized and remaining storage cells for that media type are displayed.

Step 2 To change the number of authorized storage cells, press Enter to move the cursor to Change ?

Step 3 Select Y, press Return, and the Enter Capacity dialog appears. See Figure 4-114.

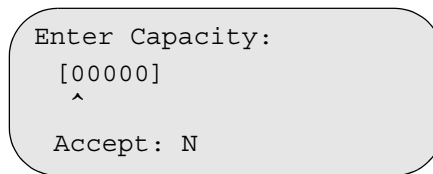



Figure 4-114 Enter Capacity Dialog

 **Note**
The Up and Down arrows change a digit from 0 to 9. Enter accepts the changed digit then moves the cursor to the next digit. Continue until the new capacity has been entered.

- Step 4** Enter the new capacity (enter leading zeros if necessary), and press Return.
- Step 5** To accept the new capacity select Y, press Return, and the Enter Authorization Code dialog appears. See Figure 4-115.

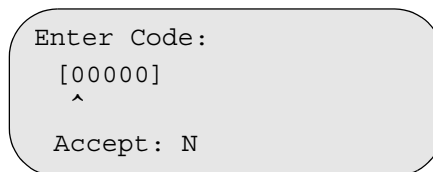

Figure 4-115 Enter Authorization Code Dialog

- Step 6** Enter the five digit authorization code and press Return.
- Step 7** Select Y to Accept, press Return, and the Acceptance Screen appears. See Figure 4-116 on page 4-81.

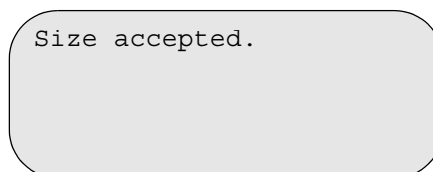
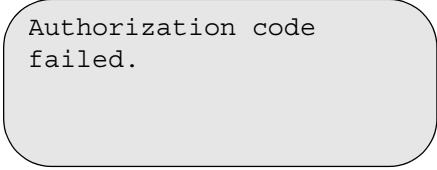

Figure 4-116 Acceptance Screen

If the authorization code is inaccurate the Authorization Failed screen appears. See Figure 4-117.



Authorization code
failed.

Figure 4-117 Authorization Failed

Step 8 After the size is accepted, Go to *Storage Dialog* on page 4-80 to display the new library storage cell capacity.

RMU Submenu

Path: **Main Menu ▶ Setup ▶ Library ▶ RMU**

The Scalar 10K is equipped with a Remote Management Unit (RMU) to access web-based library management via the Ethernet port. Use the RMU Submenu to set the initial values of the RMU network parameters for remote access. See Figure 4-118.



>Host . . .
IP . . .

Figure 4-118 RMU Submenu

Depending on your selection, refer to:

- *Host Dialog* below
- *IP Dialog* on page 4-83

Host Dialog

Path: **Main Menu ▶ Setup ▶ Library ▶ RMU ▶ Host**

Use Host Dialog to define the host name for the RMU.
See Figure 4-119.

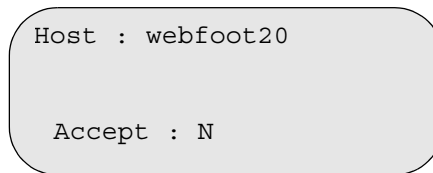

Host : webfoot20

Accept : N

Figure 4-119 Host Dialog

IP Dialog

Path: **Main Menu ▶ Setup ▶ Library ▶ RMU ▶ IP**

Use the IP Dialog to set the Internet Protocol (IP), Subnet and Gateway network addresses for library communication with the RMU. See Figure 4-120.

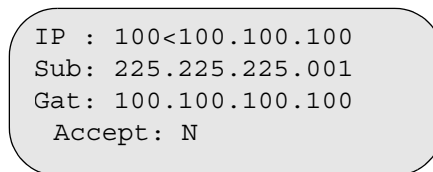

IP : 100.100.100.100
Sub: 225.225.225.001
Gat: 100.100.100.100
Accept : N

Figure 4-120 IP Dialog

Parameters	Description
IP	Indicates the IP address (four sets of numbers 0–255)
Sub	Indicates the Subnet address (four sets of numbers 0–255)
Gat	Indicates the Gateway (four sets of numbers 0–255)
Accept	Y to accept changes N to reject changes

*If **Y** is selected, the screen updates to reflect the changes. Otherwise, the changed parameters continue to display but no action is taken.*

More Submenu

Path: Main Menu ► Setup ► Library ► More

Use the More Submenu to view and change the advanced configuration, calibration, or cartridge parameters and the inventory parameters for the library. See Figure 4-121.

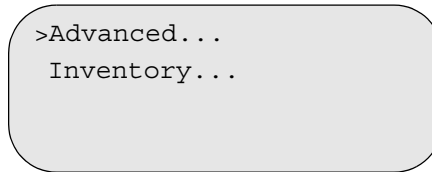

Figure 4-121 More Submenu

Depending on your selection, refer to:

- *Advanced Dialog* below
- *Inventory Dialog* on page 4-86

Advanced Dialog

Path: Main Menu ► Setup ► Library ► More ► Advanced

Use the Advanced Dialog to enable or disable the automatic configuration, calibration, or cartridge scan when the library power has been cycled. See Figure 4-122 on page 4-84.



If Auto Inventory is disabled, the element status is not known until the host issues an Initialize Status command or an Inventory is performed via the operator panel.

If Auto Inventory is enabled, an automatic cartridge inventory is executed on each power cycle.



Any changes in the Operating Mode parameter value should be made by authorized Service Personnel. The default is set to 2.

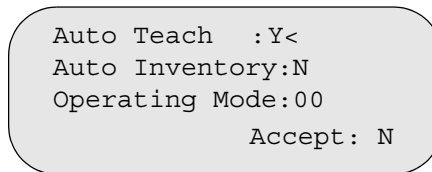

Figure 4-122 Advanced Dialog

Parameters	Description
Auto Teach	<p>Y to enable Auto Teach for automatic configuration and calibration on each power cycle.</p> <p>N to disable Auto Teach on each power cycle.</p>
Auto Inventory	<p>Y to enable Auto Inventory for automatic cartridge scanning inventory on each power cycle.</p> <p>N to disable Auto Inventory on each power cycle.</p>
Operating Mode	<p>0 to select Normal mode of operation. In this mode, the library does not wait after a drive is reported to be ejected, and the library does not issue and EJECT command (these commands must be issued by the host application).</p> <p>1 to select a 3 second delay before a Get operation is performed on a drive after detecting that a tape was ejected.</p> <p>2 to allow the Scalar 10K to issue an UNLOAD command to the drive if the cartridge is not ejected by the host. This is the default setting.</p> <p>3 to activate options 1 and 2.</p> <p>4 to disable automatic cartridge recovery on PUT failures.</p> <p>5 to activate options 1 and 4.</p> <p>6 to activate options 2 and 4.</p> <p>7 to activate options 3 and 4.</p>
Accept	<p>Y to accept changes.</p> <p>N to reject changes.</p>

*If **Y** is selected, the screen updates to reflect the changes. Otherwise, the changed parameters continue to display but no action is taken.*

Inventory Dialog

Path: **Main Menu ▶ Setup ▶ Library ▶ More ▶ Inventory**

Use the Inventory Dialog to enable or disable the normal or enhanced inventory settings. See Figure 4-123 on page 4-86. The enhanced selection improves the inventory method for reverse printed labels.

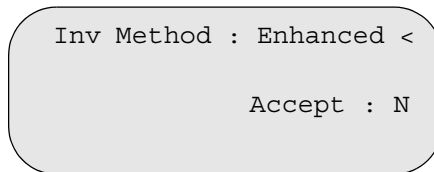

Figure 4-123 Inventory Dialog

Parameters	Description
Normal	Y to enable Normal method. N to disable Normal method.
Enhanced	Y to enable Enhanced method. N to disable Enhanced method.
Accept	Y to accept changes. N to reject changes.

*If **Y** is selected to accept changes, the inventory method is saved and the previous screen displays. Otherwise, the changed parameters continue to display but no action is taken.*

Drives Submenu

Path: **Main Menu ▶ Setup ▶ Drives**

Use the Drives Submenu to modify a drive SCSI/loop ID, change the Tape Alert Notification setting, use the Tape Alert Notify Configuration Dialog, or view the Logical Serial Number.

See Figure 4-124.

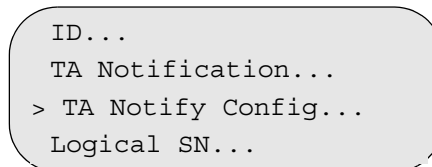

Figure 4-124 Drives Submenu

ID Dialog

Path: Main Menu ► Setup ► Drives ► ID

Use the ID Dialog to change a SCSI/loop ID of a new or current drive. See Figure 4-125.

Note: If you change any settings, you must Vary Off and Vary On the drive to apply the new settings.

```

Enter SOURCE
Coord: D 08< 4 B 01
Index: DT 00038
Accept:N
  
```

Figure 4-125 SCSI Drive Selection

Parameters	Description
Coord	<p>The first field indicates the type of cell, D for Drive</p> <p>The second field indicates the rack number (01–16)</p> <p>The third field indicates the drive section (1–4)</p> <p>The fourth field indicates the column of the section (A or B)</p> <p>The fifth field indicates the row of the column (01–06)</p>
Index	The device address associated with the selected coordinate parameter. DT = data transfer device.
Accept	Y to accept N to reject

If Y is selected, the Drive Parameters appear. See Figure 4-126.

```

Drive:          DT 00001<
[08-1-A-01]
ID: 001 New ID: 001
Port : 1      Accept: N
  
```

Figure 4-126 Drive Parameters (Fibre Drive Example)

 **Note**

Drive changes do not take place until the drive is activated.

Parameters	Description
Drive	Drive number and coordinate position
ID	Current SCSI/Loop ID of the drive
New ID	New SCSI/Loop ID of the drive
Port	Fibre channel port number. Not applicable for SCSI drives.
Accept	Y to accept changes N to reject changes

*If **Y** is selected and you are using SCSI drives, the SCSI Drive Selection screen reappears.*

*If **Y** is selected and you are using fibre channel drives, the Continuation Screen appears. See Figure 4-127.*

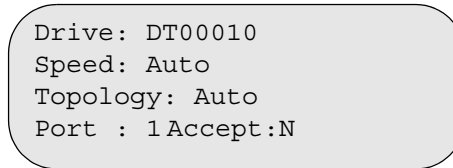

```
Drive: DT00010
Speed: Auto
Topology: Auto
Port : 1 Accept:N
```

Figure 4-127 Continuation Screen

Parameters	Description
Drive	Drive number and coordinate position
Speed	Data rate (Auto, 1 GB, 2 GB) Auto: The library auto negotiates the data transfer rate. 1 GB: 1 Gigabit/sec 2 GB: 2 Gigabit/sec
Topology	Method of connecting to fibre (Auto, Loop, Nport)
Port	Fibre channel port number
Accept	Y to accept changes N to reject changes

*If **Y** is selected and you are using single port fibre channel drives, the Fibre Drive Selection screen reappears.*

If **Y** is selected and you are using dual port fibre channel drives, the Continuation Screen appears for the second fibre channel port. See Figure 4-128 on page 4-90.

```
Drive:      DT 00001<
[08-1-A-01]
ID: 000 New ID: 000
Port : 2    Accept: N
```

Figure 4-128 Drive Parameters Screen (Port 2)

 **Note**
Drive changes do not take place until the drive is activated.

Parameters	Description
Drive	Drive number and coordinate position
ID	Current SCSI/Loop ID of the drive
New ID	New SCSI/Loop ID of the drive
Port	Fibre channel port number
Accept	Y to accept changes N to reject changes

If **Y** is selected, the Continuation Screen appears for the second fibre channel port. See Figure 4-127.

```
Drive: DT00010
Speed: Auto
Topology: Auto
Port : 2 Accept:N
```

Figure 4-129 Continuation Screen (Port 2)

Parameters	Description
Drive	Drive number and coordinate position
Speed	Data rate (Auto, 1 GB, 2 GB) Auto: The library auto negotiates the data transfer rate. 1 GB: 1 Gigabit/sec 2 GB: 2 Gigabit/sec

Topology	Method of connecting to fibre (Auto, Loop, Nport)
Port	Fibre channel port number
Accept	Y to accept changes N to reject changes

Tape Alert Notification Dialog

Path: **Main Menu ▶ Setup ▶ Drives ▶ TA Notification**

Use the TA Notification Dialog to disable or enable the reporting of tape alerts. See Figure 4-130.

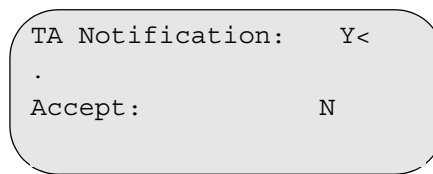

```

TA Notification:  Y<
.
Accept:          N
  
```

Figure 4-130 Tape Alert Notification Dialog

Parameters	Description
TA Notification	Y to enable the reporting of tape alerts N to disable the reporting of tape alerts
Accept	Y to accept changes N to reject changes

Tape Alert Notify Configuration Dialog

Path: Main Menu ► Setup ► Drives ► TA Notify Config

Use the TA Notify Configuration Dialog to disable or enable specific tape alerts. See Figure 4-131.

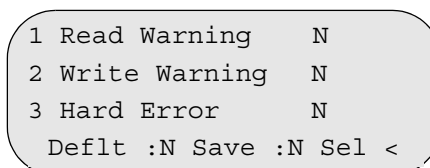

Figure 4-131 TA Notify Configuration Dialog

Parameters	Description
TA Notification	Y to enable the reporting of the selected tape alert N to disable the reporting of the selected tape alert
Deflt	Y to accept default settings N to reject default settings
Save	Y to save settings N to reject settings

Use the Enter key to select a tape alert or save option and the arrow keys to toggle between Y and N. Table 4-1 lists the specific tape alerts that can be disabled or enabled for posting to the operator panel. Tape alert names with an asterisk (*) indicate the default tape alerts posted to the operator panel by the library unless changed.

Table 4-1 Tape Alerts

TA	Name	TA	Name
1	Read Warning	2	Write Warning
3	Hard Error	4	* Media
5	* Read Failure	6	* Write Failure
7	Media Life	8	Not Data Grade
9	* Write Protect	10	No Removal
11	Cleaning Media	12	Unsupported Format
13	Recoverable Snapped Tape	14	* Unrecoverable Snapped Tape

Table 4-1 Tape Alerts

TA	Name	TA	Name
15	Memory Chip in Cartridge Failure	16	Forced Eject
17	Read Only Format	18	Tape Directory Corrupted on Load
19	Nearing Media Life	20	* Clean Now
21	Clean Periodic	22	* Expired Cleaning Media
23	Invalid Cleaning Tape	24	Retention Requested
25	Dual-Port Interface Error	26	* Cooling Fan Failure
27	Power Supply	28	Power Consumption
29	Drive Maintenance	30	* Hardware A
31	* Hardware B	32	Interface
33	* Eject Media Failure	34	Download Fail
35	Drive Humidity	36	Drive Temperature
37	* Drive Voltage	38	* Predictive Failure
39	Diagnostics Required	40	Library Hardware A
41	Library Stray Tape	42	Library Hardware B
43	Library Door	44	Library Hardware C
45	Library Cartridge	46	Library Predictive Failure
47	Not Used	48	Not Used
49	Not Used	50	Lost Statistics
51	Tape Directory Invalid at Unload	52	* Tape System Area Write Failure
53	* Tape System Area Read Failure	54	No Start of Data
55	* Load Failure	56	Unrecoverable Unload Failure
57	Library Interface Failure	58	Firmware Failure
59	WORM Medium Integrity Check Failed	60	WORM Medium Overwrite Attempted
61	Not Used	62	Not Used
63	Not Used	64	Not Used

Logical Serial Number

Path: **Main Menu ▶ Setup ▶ Drives ▶ Logical SN**

Note

When enabling or disabling the logical serial number, the library must be power cycled before the change is reflected in the library.

Use the Logical SN Dialog to enable or disable the assignment of a logical serial number to a drive that will always be the same for that drive position in the library.

The logical serial number is the last 9 digits of the world wide name assigned to the drive slot, preceded by the character "F".

LTO-1, LTO-2, LTO-3, and LTO-4 drives support logical serial numbers.

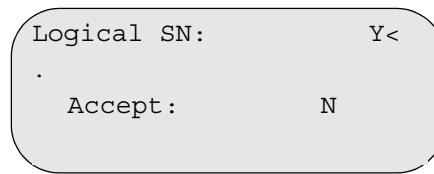

```
Logical SN:      Y<
.
Accept:         N
```

Figure 4-132 Logical Serial Number Dialog

Note

When enabled, the logical serial number replaces the manufacturer's serial number.

Parameters	Description
Logical SN	Y to assign a logical serial number. N to disable the logical serial number assignment.

Cleaning Submenu

Path: **Main Menu ▶ Setup ▶ Cleaning**

Use the Cleaning Submenu to select how and when you want to clean your drive. See Figure 4-133.

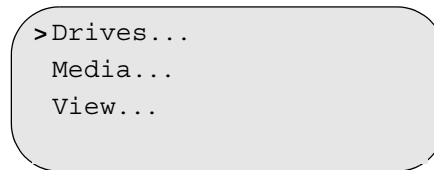

```
>Drives...
Media...
View...
```

Figure 4-133 Cleaning Submenu

Depending on your selection, refer to:

- *Drives Dialog* on page 4-96
- *Media Dialog* on page 4-97

-
-
- *View Dialog* on page 4-98

IE Station Submenu

Path: **Main Menu ▶ Setup ▶ IE Station.**

Use this option to enable or disable the Touch Teach setting at the I/E stations, if necessary. See Figure 4-134.

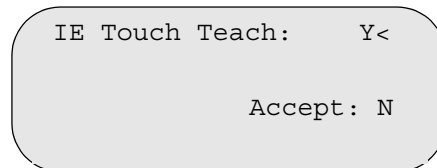

Figure 4-134 IE Station Submenu

Parameters	Description
IE Touch Teach	Y to enable the Touch Teach option at IE stations. N to disable the Touch Teach option at IE stations.

Drives Dialog

Path: Main Menu ► Setup ► Cleaning ► Drives

Use the Drives Dialog to select automatic, or scheduled (specifying a time) for cleaning your drives. See Figure 4-135.

```
AutoClean:Y<
Schedule: Delayed
Hours: 00Min :00
Accept:: N
```

Figure 4-135 Drives Dialog

 **Note**
If **Immediate** cleaning is selected, no time values can be entered.

Parameters	Description
AutoClean	Y to enable automatic drive cleaning N to reject automatic drive cleaning
Schedule	Immediate to allow drive cleaning when requested by the drive Delayed to schedule drive cleaning for requesting drives at the specified time
Hours	Hour (00–23) that cleaning should start
Min	Minute (0–59) that cleaning should start
Accept	Y to accept changes N to reject changes

*If **Y** is selected, the screen updates to reflect the changes. Otherwise, the changed parameters continue to display but no action is taken.*

Media Dialog

Path: Main Menu ► Setup ► Cleaning ► Media

Use the Media Dialog to specify the barcode number to choose a cleaning tape of a specific media in the library. See Figure 4-136 on page 4-97.



A BC mask is a valid, partial barcode label that can be followed by a wildcard character (*). barcode labels that match the mask are moved as cleaning tapes. The BC mask must not match more than a maximum of 127 cleaning tapes.

```
Media Type: LTO
BC : AAAAAA
^
Continue: N
```

Figure 4-136 Media Dialog

Parameters	Description
Media Type	Selects the medium type
BC	Indicates the BC mask of the cleaning cartridge(s)
Continue	Y to accept changes N to reject changes

If Y is selected for the Continue parameter value, the Usage Dialog appears. See Figure 4-137. Otherwise, the changed parameters continue to display but no action is taken.

```
Current Use: 000<
Maximum Use: 000

Accept: N
```

Figure 4-137 Usage Dialog

Parameters	Description
Current Usage	Specifies the number of times the cleaning cartridge has been used (000–511)
Maximum Usage	Specifies the number of times the cleaning cartridge can be used (000–511)

Note
If the BC mask selects more than one cleaning tape, the current and maximum usage parameter values are applied to each cleaning tape.

Accept Y to accept changes
 N to reject changes

If Y is selected, the screen updates to reflect the changes. Otherwise, the changed parameters continue to display but no action is taken.

View Dialog

Path: Main Menu ► Setup ► Cleaning ► View

Use the View Dialog to see how much a specific cleaning tape has been used. See Figure 4-138.

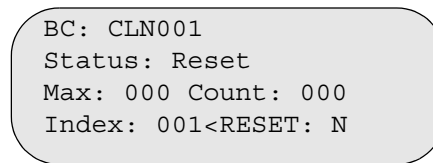

```
BC: CLN001
Status: Reset
Max: 000 Count: 000
Index: 001<RESET: N
```

Figure 4-138 View Dialog

Parameters	Description
BC	Indicates the cleaning tape barcode label
Status	Expired: Cleaning tape has expired Missing: Configured cleaning tape is not present within the library Reset: Cleaning tape not configured Valid: Cleaning tape is configured and is usable
Max	Indicates the maximum allowed usage count (000–511)
Count	Indicates the current usage count
Index	Indicates the current cleaning tape database index
RESET	Y to accept changes N to reject changes

If Y is selected for the Reset parameter value, the changed parameter values are accepted. Otherwise, the changed parameters continue to display but no action is taken.

Utils Menu

Path: **Main Menu ▶ Utils**

Use the Utils Menu to perform library utilities. For example, set screen controls or date and time. See Figure 4-139.



Figure 4-139 Utils Menu

Depending on your selection, refer to:

- *Library Submenu* below
- *Drives Submenu* on page 4-106
- *Towers Submenu* on page 4-38

Library Submenu

Path: **Main Menu ▶ Utils ▶ Library**

Use the Library Submenu to set your operator panel parameters, change passwords, enable the audio alarm, or set the time and date. See Figure 4-140.

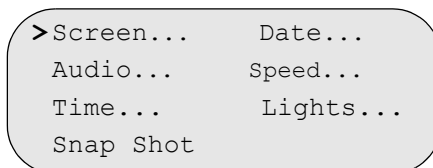

Figure 4-140 Library Submenu

Depending on your selection, refer to:

- *Screen Dialog* on page 4-100
- *Audio Dialog* on page 4-102
- *Time Dialog* on page 4-103
- *Snap Shot Screen* on page 4-104
- *Date Dialog* on page 4-104
- *Speed Dialog* on page 4-105
- *Lights Dialog* on page 4-105

Screen Dialog

Path: Main Menu ► Utils ► Library ► Screen

Use the Screen Dialog to control the operator panel LCD screen. See Figure 4-141.

```
Backlight Enable: Y<
Use Screen Saver: N

Accept: N
```

Figure 4-141 Screen Dialog

Parameters	Description
Backlight Enable	Y to enable LCD backlighting N to disable LCD backlighting
Use Screen Saver	Y to enable the screen saver N to disable the screen saver
Accept	Y to accept changes N to reject changes

If Y is selected for Use Screen Saver and Accept parameters, the Timeout Value Dialog appears. See Figure 4-142. Otherwise, the screen returns to the Library Submenu. See Figure 4-140 on page 4-99.

```
Timeout Value: 30<
Password Enable: N

Accept: N
```

Figure 4-142 Timeout Value Dialog

Parameters	Description
Timeout Value	10–60 minutes (default = 30)
Password enable	Y to enable a screen saver password N to disable a screen saver password
Accept	Y to accept changes N to reject changes

If Password enable changes from N to Y or Y to N and Accept changes to Y, the Password Dialog appears. See

 **Note**
Password enable can change from Y to N only if a password was previously set.

Figure 4-143. Otherwise, the screen returns to the Library Submenu. See Figure 4-140 on page 4-99.



```
Enter password:
[0000]
^
Accept : N
```

Figure 4-143 Password Dialog

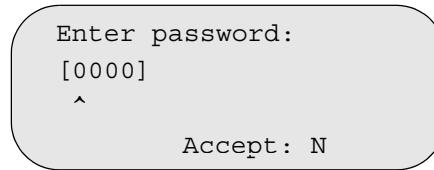
Parameters	Description
Password	Selects the password (0000–9999)
Accept	Y to accept changes N to reject changes

If Y is selected while the Password enable is set to Y, the password is changed. See Figure 4-144.

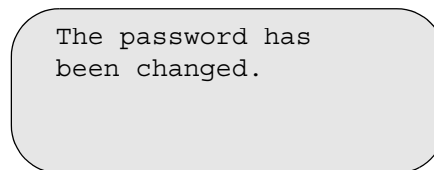

```
The password has
been changed.
```

Figure 4-144 Password Change Dialog

Otherwise, if Y is selected while the Password enable is set to N, the password protection is removed. If the password is entered incorrectly, the following Invalid Dialog appears. See Figure 4-145.

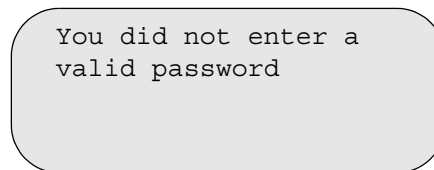

```
You did not enter a
valid password
```

Figure 4-145 Invalid Password Dialog

Press the  button to return to the Password Dialog.

Audio Dialog

Path: Main Menu ► Utils ► Library ► Audio

Use the Audio Dialog to enable or disable the audio alarm. See Figure 4-146.

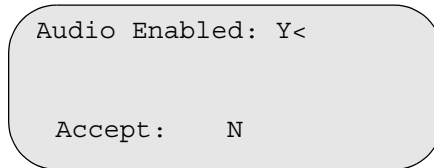

Audio Enabled: Y<
Accept: N

Figure 4-146 Audio Dialog

Parameters	Description
Audio Enable	Y to enable audio N to disable audio
Accept	Y to accept changes N to reject changes

If Y is selected, the screen updates to reflect the changes. Otherwise, the changed parameters continue to display but no action is taken.

Time Dialog

Path: Main Menu ► Utils ► Library ► Time Dialog

Use the Time Dialog to set the library 24 hour time format. See Figure 4-147.



The library does not automatically adjust for Daylight Savings Time.

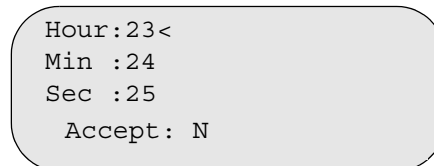

```
Hour:23<
Min :24
Sec :25
Accept: N
```

Figure 4-147 Time Dialog

Parameters	Description
Hour	Displays the hour of the day (00–23)
Min	Displays the minute of the hour (00–59)
Sec	Displays the second of the minute (00–59)
Accept	Y to accept changes N to reject changes

If Y is selected, the screen updates to reflect the changes. Otherwise, the changed parameters continue to display but no action is taken.

Snap Shot Screen

Path: Main Menu ► Utils ► Library ► Snap Shot

Use Snap Shot to capture the current operating state of the library to include, database, log, parameter, and trace information. The Snap Shot may be retrieved by a SCSI READ BUFFER command. See Figure 4-148.

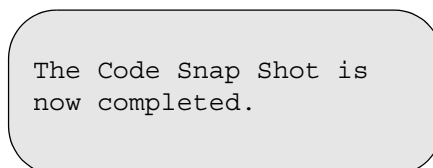

Figure 4-148 Snapshot Response Screen

Date Dialog

Path: Main Menu ► Utils ► Library ► Date

Use the Date Dialog set the library date. See Figure 4-149.

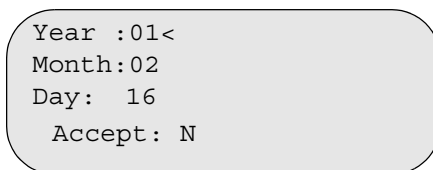

Figure 4-149 Date Dialog

Parameters	Description
Year	Displays the last two digits of the year (00–99)
Month	Displays the two digits of the month (01–12)
Day	Displays the two digits of the day (01–31)
Accept	Y to accept changes N to reject changes

If Y is selected, the screen updates to reflect the changes. Otherwise, the changed parameters continue to display but no action is taken.

Speed Dialog

Path: Main Menu ► Utils ► Library ► Speed

Use the Speed Dialog to change the current operating speed of the accessor. The accessor speed automatically increases or decreases as the frequency of motion commands is greater than or less than certain thresholds.
See Figure 4-150.

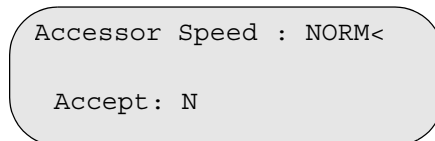

Figure 4-150 Accessor Speed Screen

Parameters	Description
Accessor Speed	NORM to run at the normal speed MED to run at 90% of normal SLOW to run at a slower speed
Accept	Y to accept changes N to reject changes

Lights Dialog

Path: Main Menu ► Utils ► Library ► Lights

Use the Lights Dialog to change the time setting for the aisle lights.
See Figure 4-151.

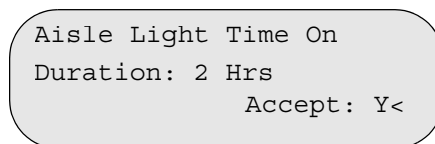

Figure 4-151 Lights Screen

Parameters	Description
Duration Value	Indicates how many hours the lights are to be on. (2, 4, 6, 8, or Always). 2 hours is the default value.
Accept	Y to accept changes N to reject changes

Drives Submenu

Path: **Main Menu ► Utils ► Drives**

Use the Drives Submenu to change drive status or operations. See Figure 4-152.

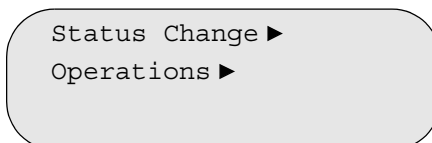

Figure 4-152 Drives Submenu

Depending on your selection, refer to:

- *Status Change Submenu* on page 4-106
- *Operations Submenu* on page 4-111

Status Change Submenu

Path: **Main Menu ► Utils ► Drives ► Status Change**

Use the Status Change Submenu to prepare the drive for use or to remove the drive from service. See Figure 4-153.

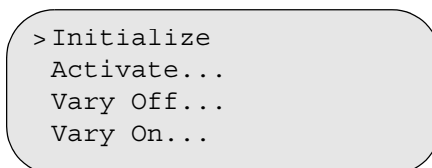

Figure 4-153 Status Change Submenu

Depending on your selection, refer to:

- *Initialize Dialog* below
- *Activate Dialog* on page 4-108
- *Vary Off Dialog* on page 4-109
- *Vary On Dialog* on page 4-110

Initialize Dialog

Path: **Main Menu ▶ Utils ▶ Drives ▶ Status Change ▶ Initialize**

Use the Initialize Dialog to prepare the drive for use. This dialog checks all drives for power and SCSI IDs. See Figure 4-154 and Figure 4-155.

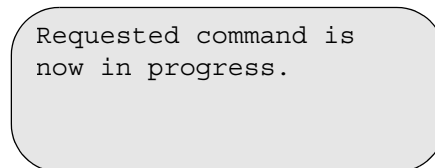

Figure 4-154 Initialize Dialog

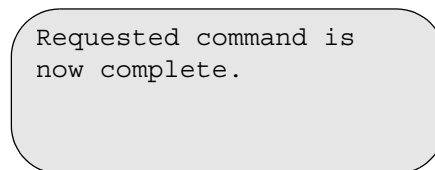

Figure 4-155 Command Complete Screen

Activate Dialog

Path: **Main Menu ▶ Utils ▶ Drives ▶ Status Change ▶ Activate**

Use the Activate Dialog to select and use any drive in the library. See Figure 4-156.

```
Enter SOURCE
Coord:D 03 1 A01<
Index:DT 00001
Accept: N
```

Figure 4-156 Activate Dialog

Parameters	Description
Coord	The first field indicates the type of cell (D for Drive) The second field indicates the rack number (01–4) The third field indicates the drive bay section (1–4) The fourth field indicates the column of the section (A–B) The fifth field indicates the row of the column (01–6)
Index	The device address associated with the selected coordinate parameter
Accept	Y to accept N to reject

The Activate Drive Screen appears. See Figure 4-157. Refer to Initialize Dialog on page 4-107, Vary Off Dialog on page 4-109, or Vary On Dialog on page 4-110.

```
Drive:DT00001
[03-1-A-01]
Status:PRESENT
Activate:SKIP<
```

Figure 4-157 Activate Drive

Parameters	Description
Drive	The device address associated with the selected coordinate
Status	PRESENT, OFFLINE, ONLINE, or NOT PRESENT
Activate	ON to activate OFF to deactivate SKIP to skip the drive

Vary Off Dialog

Path: Main Menu ► Utils ► Drives ► Status Change ► Vary Off

 **Note**
Power off the drive to change the drive.

Use the Vary Off Dialog to notify the library that the selected drive is not available for use. See Figure 4-158.

```
Enter SOURCE
Coord: D 08< 4 B 01
Index: DT 00038
Accept:N
```

Figure 4-158 Vary Off Dialog

Parameters	Description
Coord	The first field indicates the type of cell (D for Drive)
	The second field indicates the rack number (01–16)
	The third field indicates the drive bay section (1–4)
	The fourth field indicates the column of the section (A–B)
	The fifth field indicates the row of the column (01–6)
Index	The device address associated with the selected coordinate parameter
Accept	Y to accept N to reject

 **Note**
When a Vary Off command is performed on a drive that is not working properly, the library might post a SAC A4 error. This is an indication of a sled that has stopped communicating. See Table 6-2 on page 6-15 for more information on the SAC A4 error.

Vary On Dialog

Path: **Main Menu ▶ Utils ▶ Drives ▶ Status Change ▶ Vary On**

The Vary On dialog appears only if a drive has been varied off previously. The Status is always OFFLINE. If multiple drives are varied off, you can scroll to choose which drive to Vary On. Otherwise, the only choice is to accept or reject the status of the drive.

Use the Vary On Dialog to notify the library that the selected drive is available for use. The library scans, teaches, and activates the selected drive. See Figure 4-159.

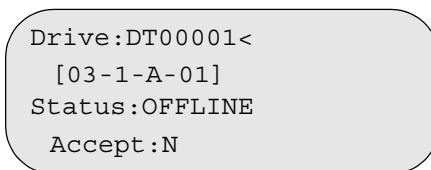

```
Drive:DT00001<  
[03-1-A-01]  
Status:OFFLINE  
Accept:N
```

Figure 4-159 Vary On Dialog

Parameters	Description
Drive	The device address associated with the selected coordinate parameter
Status	PRESENT, OFFLINE, ONLINE, or NOT PRESENT
Accept	Y to accept N to reject

Operations Submenu

Path: **Main Menu** ► **Utils** ► **Drives** ► **Operations**

Use the Operations Submenu to update the microcode or perform various drive functions. See Figure 4-160.

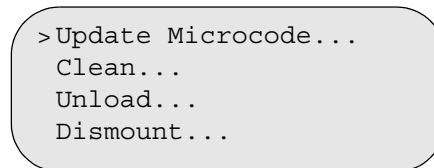

Figure 4-160 Operations Submenu

Depending on your selection, refer to:

- *Update Microcode Dialog* on page 4-112
- *Clean Drives Dialog* on page 4-114
- *Unload Drives Dialog* on page 4-116
- *Dismount Drives Dialog* on page 4-118

Update Microcode Dialog

Path: **Main Menu ► Utils ► Drives ► Operations ► Update Microcode**

Use the Update Microcode Dialog to initiate a drive firmware update. See Figure 4-161.



The operator must determine the location coordinate and index of the firmware update tape prior to following this procedure.

```
Enter SOURCE
Coord: S 01< 1 A 01
Index: ST 00001
Accept : N
```

Figure 4-161 Update Microcode Dialog

Parameters	Description
Coord	The first field indicates the type of cell (D for Drive) The second field indicates the rack number (01–16) The third field indicates the drive bay section (1–4) The fourth field indicates the column of the section (A–B) The fifth field indicates the row of the column (01–6)
Index	The device address associated with the selected coordinate parameter
Accept	Y to accept N to reject

If Y is selected, the Starting Drive and Ending Drive screens appear. See Figure 4-162 on page 4-113 and Figure 4-163 on page 4-113.

```

Enter Starting Drive
Coord: D 03< 1 A 01
Index: ST 00001
Accept : N

```

Figure 4-162 Starting Drive

```

Enter Ending Drive
Coord: D 03< 1 A 01
Index: ST 00001
Accept : N

```

Figure 4-163 Ending Drive

If Y is selected, the Update Microcode screen appears and shows the drive location of the drive being updated. See Figure 4-164. Otherwise, the changed actions continue to display but no action is taken.

```

-UPDATE MICROCODE-
Drive: D31A1
Status: Running
Cancel: N<

```

Figure 4-164 Update Microcode Screen

Parameters	Description
Status	<p>Running indicates that the current command is in progress</p> <p>Completed indicates the firmware on all the drives in the cycle has been updated.</p> <p>Canceled indicates the cycle has been canceled</p> <p>ERROR! indicates an error has occurred</p>
Cancel	<p>Y to cancel the cycle</p> <p>N to continue the cycle</p>

If Y is selected for the Cancel parameter, the cycle is canceled and the Cancel parameter does not appear.

Clean Drives Dialog

Path: Main Menu ► Utils ► Drives ► Operations ► Clean Drives

Use the Clean Drives Dialog to initiate a drive cleaning operation. See Figure 4-165.

```
Enter TARGET
Coord: D< 03 1 A 05
Index: DT 00009
Accept: N
```

Figure 4-165 Clean Drives Dialog

Parameters	Description
Coord	The first field indicates the type of cell (D for Drive) The second field indicates the rack number (01–4) The third field indicates the storage cell section (1–4) The fourth field indicates the column of the section (A–B) The fifth field indicates the row of the column (01–6)
Index	The device address associated with the selected coordinate parameter
Accept	Y to accept N to reject

If Y is selected, the Progress Screen appears, followed by the Response Screen. See Figure 4-166 on page 4-115 and Figure 4-167 on page 4-115. Otherwise, the changed actions continue to display but no action is taken.

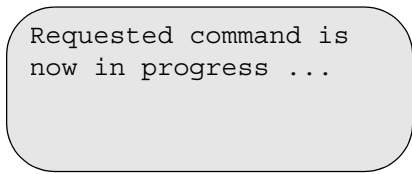
A light gray rounded rectangular box containing the text "Requested command is now in progress ...".

Requested command is
now in progress ...

Figure 4-166 Progress Screen

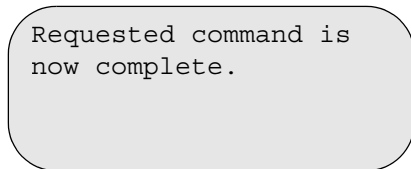
A light gray rounded rectangular box containing the text "Requested command is now complete.".

Requested command is
now complete.

Figure 4-167 Response Screen

Unload Drives Dialog

Path: **Main Menu ▶ Utils ▶ Drives ▶ Operations ▶ Unload Drives**

Use the Unload Drives dialog to eject a tape from the specified drive. See Figure 4-168.

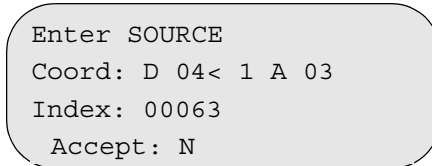

```
Enter SOURCE
Coord: D 04< 1 A 03
Index: 00063
Accept: N
```

Figure 4-168 Unload Drives Dialog

Parameters	Description
Coord	The first field indicates the type of cell (D for Drive) The second field indicates the rack number (01–16) The third field indicates the drive bay section (1–4) The fourth field indicates the column of the section (A–B) The fifth field indicates the row of the column (01–6)
Index	The device address associated with the selected coordinate parameter
Accept	Y to accept N to reject

*If **Y** is selected, the Progress Dialog followed by the Response Dialog appears. See Figure 4-169 on page 4-117 and Figure 4-170 on page 4-117. Otherwise, the changed actions continue to display but no action is taken.*

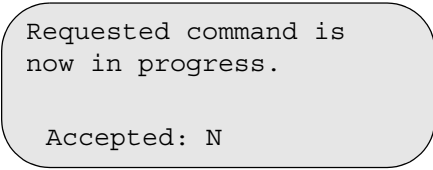
A rounded rectangular dialog box with a light gray background and a black border. It contains two lines of text in a monospaced font.

Requested command is
now in progress.

Accepted: N

Figure 4-169 Progress Dialog

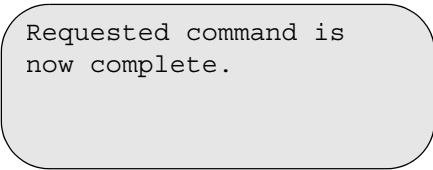
A rounded rectangular dialog box with a light gray background and a black border. It contains one line of text in a monospaced font.

Requested command is
now complete.

Figure 4-170 Response Dialog

Dismount Drives Dialog

Path: **Main Menu ► Utils ► Drives ► Operations ► Dismount Drives**

Use the Dismount Drives dialog to eject a tape from the specified drive and bring it back to its home position. See Figure 4-171.

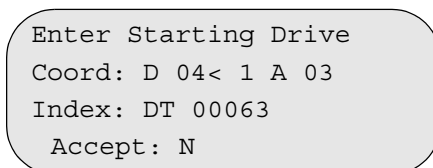

```
Enter Starting Drive
Coord: D 04< 1 A 03
Index: DT 00063
Accept: N
```

Figure 4-171 Starting Drive

Parameters	Description
Coord	The first field indicates the type of cell (D for Drive) The second field indicates the rack number (01–16) The third field indicates the drive bay section (1–4) The fourth field indicates the column of the section (A–B) The fifth field indicates the row of the column (01–6)
Index	The device address associated with the selected coordinate parameter
Accept	Y to accept N to reject

*If **Y** is selected, the Ending Drive Dialog, Progress Dialog, and Response Dialog appear. See Figure 4-172, Figure 4-173, and Figure 4-174. Otherwise, the changed actions continue to display but no action is taken.*

```
Enter Ending Drive
Coord: D 04< 1 A 03
Index: DT 00063
Accept: N
```

Figure 4-172 Ending Drive

```
--DISMOUNTING DRIVES--
Drive: 41A3
Status: Running
Cancel: N
```

Figure 4-173 Progress Dialog

```
--DISMOUNTING DRIVES--
Count: xx
Status: Completed
```

Figure 4-174 Response Dialog

Towers Submenu

Path: **Main Menu ► Utils ► Towers**

Use the Towers Submenu to initialize or change the status of the selected tower. See Figure 4-175.

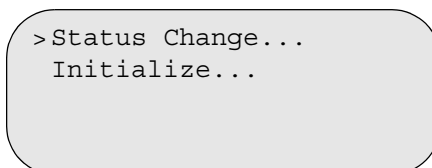

Figure 4-175 Towers Submenu

Depending on your selection, refer to:

- *Status Change Dialog* below
- *Initialize Dialog* on page 4-122

Status Change Dialog

Path: **Main Menu ► Utils ► Towers ► Status Change**

Use the Status Change to change who has access to the tower, the library or the user. See Figure 4-176.

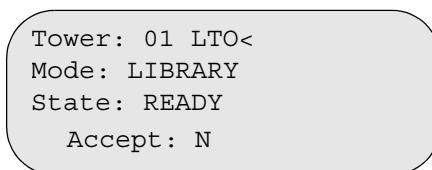

Figure 4-176 Set Status Dialog

Parameters	Description
Tower	Displays the tower rack number, media type of the installed towers (01–16), and “DUAL” if the tower is shared on a dual aisle system.
Mode	Displays the mode of the tower (LIBRARY, SERVICE, USER)
State	Displays the state of the tower (READY, NOT READY)
Accept	Y to accept the changes N to reject the changes

If Y is selected, the current parameter values are accepted. Otherwise the changed parameter values continue to be displayed, and no action is taken.

If SERVICE or USER mode is selected, TOWER MODE CHANGE appears. See Figure 4-177.

```
TOWER MODE CHANGE
This selection will
prevent host access.
Continue: N <
```

Figure 4-177 Tower Mode Change

If Continue is accepted the following displays appear. Otherwise the changed parameter values continue to be displayed, and no action is taken. See Figure 4-178 and Figure 4-179.

```
Requested command is
now in progress.
```

Figure 4-178 Tower Return Dialog

```
Inventory Tower: 01?

Accept: N <
```

Figure 4-179 Inventory Tower

If Y is selected, the tower inventory begins. Otherwise the changed parameter values continue to be displayed, and no action is taken.

Initialize Dialog

Path: **Main Menu ▶ Utils ▶ Towers ▶ Initialize**

Use the Initialize Dialog to provide power to all towers and send the towers to the home position. See Figure 4-180, Figure 4-181, and Figure 4-182.

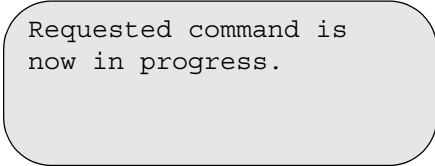

Requested command is
now in progress.

Figure 4-180 Initialize Dialog

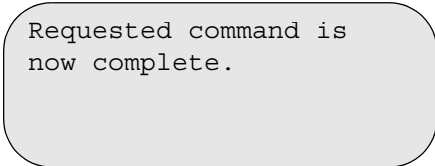

Requested command is
now complete.

Figure 4-181 Command Complete

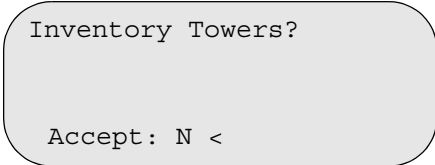

Inventory Towers?

Accept: N <

Figure 4-182 Inventory Tower

If Y is selected, the tower inventory begins.

Service Menu

Path: **Main Menu ▶ Service**

Use the Service Menu to select library diagnostics or exercisers. These options should only be used by trained service representatives or administrators. See Figure 4-183.



Figure 4-183 Service Menu

Depending on your selection, refer to:

- *Start Dialog* below
- *Diags Submenu* on page 4-125
- *Teach Submenu* on page 4-156
- *SAC Dialog* on page 4-168
- *Demo Dialog* on page 4-169
- *Verify Submenu* on page 4-171
- *Advanced Submenu* on page 4-172

Start Dialog

Path: **Main Menu ▶ Service ▶ Start**

Use the Start dialog to check and reset Preventative Maintenance (PM) SAC codes. The Dialog flow is either Start Dialog with No Errors or Start Dialog with Errors (displays the last SAC Code). See Figure 4-184.

 **Note**
You can press escape to display the last SAC code.

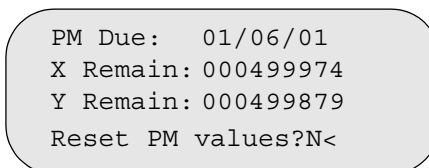

Figure 4-184 Preventive Maintenance Due Dialog

Parameters	Description
Reset PM values	Y to reset PM values N to keep PM values

If Y is selected for the Reset PM values parameter value, the Confirm Change Dialog is displayed.

See Figure 4-185. Otherwise, the flow continues with either the Start Dialog with No Errors, see Figure 4-186, or the Start Dialog with Errors, see Figure 4-187.

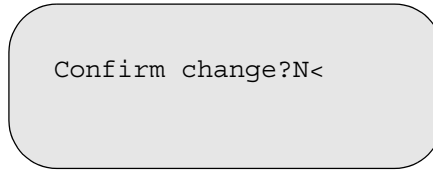



Figure 4-185 Confirm Change Dialog

Parameters	Description
Confirm change	Y to accept changes to PM values N to reject changes to PM values

 **Note**

Press the  button or the  button to scroll between SAC values.

If Y is selected for the Confirm Change parameter value and no errors were present, the Start Dialog with No Errors is displayed. See Figure 4-186.

If Y is selected for the Confirm Change parameter value and recent errors were present, the Start Dialog with Errors is displayed. See Figure 4-187 on page 4-125. This option provides information for a service call.

The Service Action Code (SAC) is based on the displayed error code. Refer to Service Action Codes on page 6-11 for additional information. Refer to document number 600418, Scalar 10K Maintenance Manual for a course of action related to the displayed SAC.

If N is selected for the Confirm Change parameter value, the Preventative Maintenance Due is displayed.

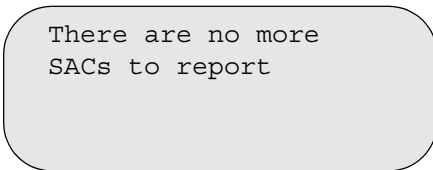



Figure 4-186 Start Dialog with No Errors

```
Found SAC at :
02/05/01  14:04:38.68
SAC   : E1
Error: 0x07110301
```

Figure 4-187 Start Dialog with Errors

Diags Submenu

 **Note**
Diagnostics are grouped according to functional areas.

Path: **Main Menu ▶ Service ▶ Diags**

Use the Diags Submenu to run library diagnostics.
See Figure 4-188.

```
> Accessor ▶   DI/DO ▶
Gripper ▶     SelfTest...
Scanner ▶     P/S ▶
Tower ▶
```

Figure 4-188 Diags Submenu

Depending on your selection, refer to:

- *Accessor Submenu* on page 4-126
- *Gripper Submenu* on page 4-129
- *Scanner Submenu* on page 4-136
- *Tower Submenu* on page 4-140
- *DI/DO Submenu* on page 4-143
- *Self Test Dialog* on page 4-151
- *P/S Submenu* on page 4-152

Accessor Submenu

Path: Main Menu ► Service ► Diags ► Accessor

Use the Accessor Submenu to move the accessor.
See Figure 4-189.

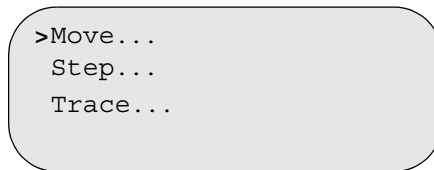

Figure 4-189 Accessor Submenu

Depending on your selection, refer to:

- *Move Dialog* below
- *Step* on page 4-128
- *Trace* on page 4-129

Move Dialog

Path: **Main Menu ▶ Service ▶ Diags ▶ Accessor ▶ Move**

Use the Move dialog to move the accessor in a figure eight pattern without accessing cartridges. See Figure 4-190.

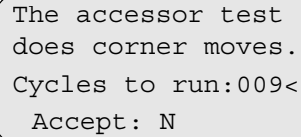

The accessor test
does corner moves.
Cycles to run:009<
Accept: N

Figure 4-190 Move Dialog

Parameters	Description
Cycles to Run	Indicates the desired cycle count (001–999)
Accept	Y to accept changes N to reject changes

If Y is selected, the Response Screen appears. See Figure 4-191 on page 4-127. Otherwise, the changed parameters continue to display but no action is taken.

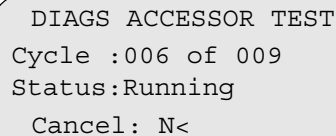

DIAGS ACCESSOR TEST
Cycle :006 of 009
Status:Running
Cancel: N<

Figure 4-191 Response Dialog

Parameters	Description
Cancel	Y to cancel the test. N to continue running the test.
Cycle	Displays the number of completed test cycles of the requested cycles
Status	Displays the status of the selected cycle (Running, completed, Error, Cancelled)
Cancel	Y to cancel the test. N to continue running the test.

If Y is selected for the Cancel parameter value, the test is canceled. Otherwise, the test continues.

 **Note**
If the operation stops, the **Cancel** parameter no longer displays.

Step

Path: **Main Menu ▶ Service ▶ Diags ▶ Accessor ▶ Step**

Use Step to provide low level accessor control. The option should be used only by trained service personnel. See Figure 4-192.

This test should be
used by trained
personnel ONLY!
Continue: N<

Figure 4-192 Step Screen

 **Note**
There is a .3mm tolerance for each x-axis or y-axis step. The Step screen display does not show the exact step movement.

Parameters	Description
Continue	Y to continue the test. N to cancel the test

If Y is selected for the Continue parameter value, the Response Screen appears. See Figure 4-193.

Use Arrows to Move
X axis : 1057.9mm<
Y axis : 0000.0mm
Amount : 001.0mm

Figure 4-193 Movement Screen

Parameters	Description
X axis	Displays X axis location
Y axis	Displays Y axis location
Amount	Displays the move step distance (1, 10–100 mm)

Trace

Path: **Main Menu ▶ Service ▶ Diags ▶ Accessor ▶ Trace**

Use Trace to monitor the following error of the accessor motors and print the error information to the library trace.

The option should be used only by trained service personnel. See Figure 4-194.

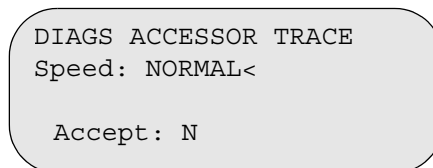

Figure 4-194 Accessor Trace Screen

Parameters	Description
Speed	NORMAL, MEDIUM, or SLOW. The speed cannot be faster than the system setting

Gripper Submenu

Path: **Main Menu ▶ Service ▶ Diags ▶ Gripper**

Use the Gripper Submenu to select Get/Put actions for storage or a drive. See Figure 4-195.

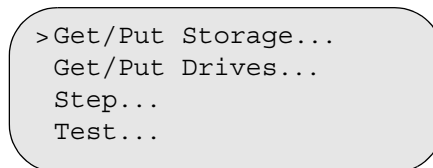

Figure 4-195 Gripper Submenu

Depending on your selection, refer to:

- *Get/Put Storage Dialog* below
- *Get/Put Drives Dialog* on page 4-133
- *Step Dialog* on page 4-135
- *Test Dialog* on page 4-136

Get/Put Storage Dialog

Path: Main Menu ► Service ► Diags ► Gripper ► Get/Put Storage

Use the Get/Put Storage Dialog to start an in place get and put of all cartridges in a specified range. No element to element movements are allowed. See Figure 4-196.

```
The gripper test
will get/put media
Cycles to run:009<
[more]
```

Figure 4-196 Get/Put Storage Dialog

Parameters	Description
Cycles to run	Displays the number of cycles to run (1–999)
[more]	More selections on the Continuation Dialog

When [more] is selected, the Continuation Dialog appears. See Figure 4-197 on page 4-130.

```
Enter SOURCE
Coord: S 01< 1 A 01
Index: DT 00001
Accept: N
```

Figure 4-197 Continuation Dialog

Parameters	Description
Coord	The first field indicates the type of cell (D for Drive) The second field indicates the rack number (01–16) The third field indicates the storage cell section (1–4)

	The fourth field indicates the column of the section (A–B)
	The fifth field indicates the row of the column (01–6)
Index	The device address associated with the selected coordinate parameter
Accept	Y to accept N to reject

If Y is selected, the Number of Elements Dialog appears. See Figure 4-198. Otherwise, the changed parameters continue to display but no action is taken.

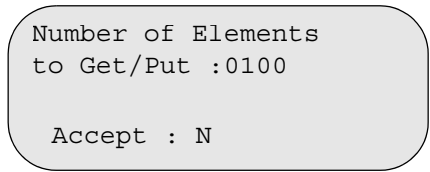

Figure 4-198 Number of Elements Dialog

Parameters	Description
Get/Put	Selects the number of elements where get/put operations are applied (0000–1181)
Accept	Y to accept changes N to reject changes

If Y is selected, the Response Dialog appears. See Figure 4-199. Otherwise, the changed parameters continue to display but no action is taken.

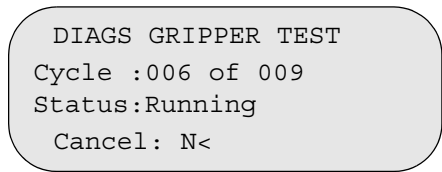



Figure 4-199 Response Dialog

 **Note**
If the operation stops, the **Cancel** parameter no longer displays.

Parameters	Values
Cycle	The number of completed test cycles of the requested cycles
Status	Shows the status of the indicated cycle (Running, Completed, Error, Canceled)
Cancel	Y to cancel the test. N to continue running the test.

*If **Y** is selected for the Cancel parameter value, the test is canceled. Otherwise, the test continues.*

Get/Put Drives Dialog

Path: Main Menu ► Service ► Diags ► Gripper ► Get/Put Drives

Use the Get/Put Drives dialog to perform a get and put of all cartridges in a specified range to a specific drive. See Figure 4-200.

Drives to be tested must have a cartridge loaded. If no cartridge is loaded in the drive, the drive will be skipped during the test.

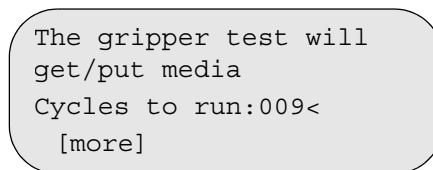

```
The gripper test will
get/put media
Cycles to run:009<
[more]
```

Figure 4-200 Get/Put Drives Dialog

Parameters	Description
Cycles to run	Displays the number of cycles to run (1–999)
[more]	More selections on the Continuation Dialog

When *[more]* is selected, the Continuation Dialog appears. See Figure 4-201.

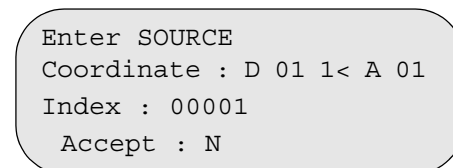

```
Enter SOURCE
Coordinate : D 01 1< A 01
Index : 00001
Accept : N
```

Figure 4-201 Continuation Dialog

Parameters	Description
Coord	The first field indicates the type of cell (I for I/E Station, D for Drive, S for Storage cell)
	The second field indicates the rack number (01–16)
	The third field indicates the storage cell section (1–5)

	The fourth field indicates the column of the section (A–P)
	The fifth field indicates the row of the column (01–15)
Index	The device address associated with the selected coordinate parameter: DT = data transfer device IE = insert/eject device ST = storage device
Accept	Y to accept N to reject

If Y is selected, the Number of Drives Dialog appears. See Figure 4-202. Otherwise, the changed parameters continue to display but no action is taken.

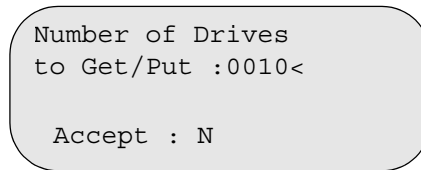



Figure 4-202 Number of Drives Dialog

Number of Drives refers to possible drive slot locations, not the actual number of drives that exist. If the source coordinate is D 01 1 A 01, and 12 is entered at the Number of Drives screen, any drives that are present in drive bay 1 and loaded with a cartridge will be included in the test. Twelve is the maximum number of drive slots available in drive bay 1.

 **Note**
Counts forward from the selected drive position to the last drive position. Does not count any drives prior to the selected drive position.

Parameters	Description
Get/Put	Selects the number of drives to apply the Get/Put operation (0000–0648 for all drives)
Accept	Y to accept changes N to reject changes

If Y is selected, the Response Dialog appears. See Figure 4-203. Otherwise, the changed parameters continue to display but no action is taken.

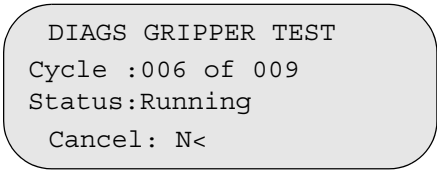

Figure 4-203 Response Dialog

Parameters	Description
Cycle	The number of completed test cycles of the requested cycles
Status	Shows the status of the indicated cycle (Running, Completed, Error, Canceled)
Cancel	Y to cancel the test N to continue running the test

If Y is selected for the Cancel parameter value, the test is canceled. Otherwise, the test continues.

Note
If the operation stops, the **Cancel** parameter no longer displays.

Step Dialog

Path: **Main Menu ▶ Service ▶ Diags ▶ Gripper ▶ Step**

Use Step to set low level control of Gripper functions. Only trained service personnel should use this function. See Figure 4-204.

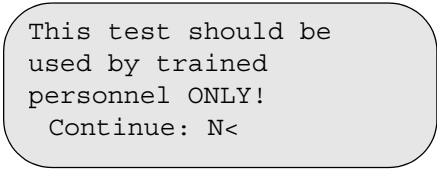
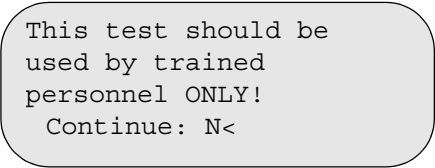

Figure 4-204 Step Screen

Test Dialog

Path: **Main Menu ▶ Service ▶ Diags ▶ Gripper ▶ Test**

Use Test to perform various tests of Gripper functions (reach, pivot, and Gripper fingers). Only trained service personnel should use this function. See Figure 4-205.



```
This test should be
used by trained
personnel ONLY!
Continue: N<
```

Figure 4-205 Test Screen

Scanner Submenu

Path: **Main Menu ▶ Service ▶ Diags ▶ Scanner**

Use the Scanner Submenu to verify and test the barcode scanner. See Figure 4-206.

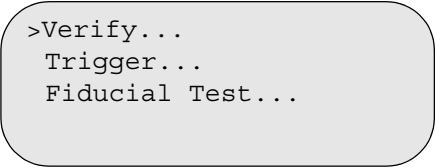

```
>Verify...
Trigger...
Fiducial Test...
```

Figure 4-206 Scanner Submenu

Depending on your selection, refer to:

- *Verify Dialog* on page 4-137
- *Trigger Dialog* on page 4-138
- *Fiducial Test Dialog* on page 4-139

Verify Dialog

Path: **Main Menu ▶ Service ▶ Diags ▶ Scanner ▶ Verify**

Use the Verify Dialog to confirm that the barcode scanner is level. This function should be used by trained service personnel. Refer to the *Scalar 10K Maintenance Guide* for the step-by-step procedure to adjust the scanner. See Figure 4-207.

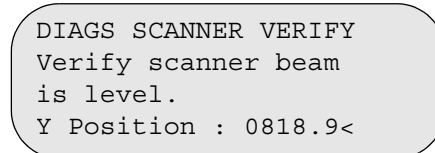

```
DIAGS SCANNER VERIFY
Verify scanner beam
is level.
Y Position : 0818.9<
```

Figure 4-207 Verify Dialog

Parameters	Description
Y Position	Displays the returned vertical position value of the scanner

Trigger Dialog

Path: **Main Menu ▶ Service ▶ Diags ▶ Scanner ▶ Trigger**

Use the Trigger Dialog to trigger the barcode scanner to read, decode, and display whatever barcode label is within the range of the beam. See Figure 4-208.

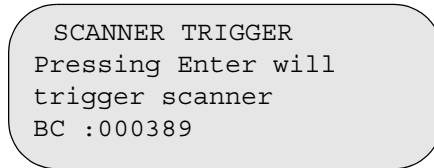

Figure 4-208 Response Screen

Parameters	Description
BC	Returns the barcode label information for the storage cartridge.

Fiducial Test Dialog

Path: Main Menu ► Service ► Diags ► Scanner ► Fiducial Test

Use the Fiducial Test dialog to test the scanner for proper operation. See Figure 4-209.

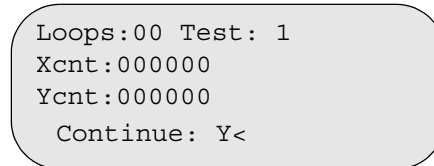

Loops:00 Test: 1
Xcnt:000000
Ycnt:000000
Continue: Y<

Figure 4-209 Fiducial Test Dialog

Parameters	Description
Test	1 reads the Insert/Eject Station 1 fiducial and displays the found edge coordinates. 2 reads the Insert/Eject Station 2 and displays the found edge coordinates.
Xcnt	Displays the x edge position count in tenths of a mm
Ycnt	Displays the Y edge position count in tenths of a mm
Continue	Y to continue running the test. N to cancel the test

Run this test several times to ensure the X and Y position counts are within 10 tenths of a mm each time the test is run.

Tower Submenu

Path: **Main Menu ▶ Service ▶ Diags ▶ Tower**

Use the Tower Submenu to step it through each position or to send the tower to the Home position. See Figure 4-210.



Figure 4-210 Tower Submenu

Depending on your selection, refer to:

- *Home Dialog* below
- *Step Dialog* on page 4-142

Home Dialog

Path: **Main Menu ▶ Service ▶ Diags ▶ Tower ▶ Home**

Use the Home Dialog to send the tower to the home position. See Figure 4-211.

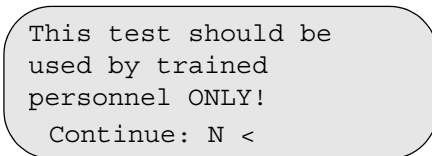

Figure 4-211 Home Dialog

Parameters	Description
Continue	Y to continue the test N to cancel the test

If Y is selected for the Continue parameter value, Tower Homing appears. See Figure 4-212.

```
Tower Homing
Tower :01 LTO

Accept : N
```

Figure 4-212 Tower Homing

If you are in SERVICE mode and Y is selected, the following displays appear and the tower goes to the homing position. See Figure 4-213 and Figure 4-214.

If you are not in SERVICE mode and Y is selected, the WRONG TOWER MODE display appears, select Accept to change to SERVICE mode. See Figure 4-215.

```
Requested command is
now in progress.
```

Figure 4-213 Initialize Dialog

```
Requested command is
now complete.
```

Figure 4-214 Command Complete

```
WRONG TOWER MODE
Set mode for TCL (01)
to SERVICE.
Accept: N <
```

Figure 4-215 Wrong Tower Mode

Step Dialog

Path: **Main Menu ▶ Service ▶ Diags ▶ Tower ▶ Step**

Use the Step Dialog to move the tower through each position. See Figure 4-216.

This test should be
used by trained
personnel ONLY!
Continue: N <

Figure 4-216 Home Dialog

Parameters	Description
Continue	Y to continue the test N to cancel the test

If you are in SERVICE mode and Y is selected for the Continue, the following display appears and the tower is ready to position. See Figure 4-217.

If you are not in SERVICE mode and Y is selected for Continue, the WRONG TOWER MODE display appears, select Accept to change to SERVICE mode. See Figure 4-218.

Position Tower
Tower: 01 LTO
Column: UNKNOWN <
Amount: 01

Figure 4-217 Position Tower

Parameters	Description
Tower	Tower to be moved (01–14, 8mm, DLT, LTO, HALF)
Column	Column number 01A–12L for DLT, LTO, HALF 01A–16P for 8mm
Amount	The step width depending on the media type

```
WRONG TOWER MODE
Set mode for TCL (01)
to SERVICE.
Accept: N <
```

Figure 4-218 Wrong Tower Mode

DI/DO Submenu

Path: **Main Menu ▶ Service ▶ Diags ▶ DI/DO**

Use the DI/DO to run loopback tests, or sensor or lock tests.
See Figure 4-219.

 **Note**
Use these tests to
isolate problems
in the system.

```
> Loopback...
Sensors ▶
Locks...
```

Figure 4-219 DI/DO Submenu

Depending on your selection, refer to:

- *Loopback Dialog* below
- *Sensors Submenu* on page 4-145
- *Locks Dialog* on page 4-150

Loopback Dialog

Path: **Main Menu ▶ Service ▶ Diags ▶ DI/DO ▶ Loopback**

Use the Loopback Dialog to send test signals from the main
control card to other system cards and return.
See Figure 4-220.

```
Device: LMC
Number: 01
Results:
Accept: N
```

Figure 4-220 Loopback Dialog

Parameters	Description
Device	Displays the loopback tests to run (LMC, LIE, LPN))
Number	Displays which device number should be tested. This field is always set to 01 because there is only one of each device to be tested in the Scalar 10K
Accept	Y to accept changes N to reject changes

*If **Y** is selected, the Response Screen appears. See Figure 4-221. Otherwise, the changed parameters continue to display but no action is taken.*

```
Device: LMC
Number: 01
Results: PASSED
Accept: N
```

Figure 4-221 Response Dialog

Parameters	Description
Results	Passed indicates that the test executed successfully Failed indicates that the test did not execute successfully
Accept	Y to accept change N to reject changes

Sensors Submenu

Path: **Main Menu ▶ Service ▶ Diags ▶ DI/DO ▶ Sensors**

Use the Sensors Submenu to test the system sensors and to view the changes in real time. See Figure 4-222.

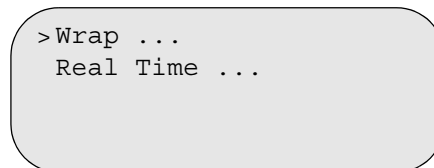

Figure 4-222 Sensors Submenu

Depending on your selection, refer to:

- *Wrap Dialog* below
- *Real Time* on page 4-147

Wrap Dialog

Path: Main Menu ► Service ► Diags ► DI/DO ► Sensors ► Wrap

Use the Wrap Dialog to test the ability of the system sensors to report state changes. See Figure 4-223.

```
Device:  ALL SENSORS<
Number:  01
Result:
                Accept: N
```

Figure 4-223 Wrap Dialog

Parameters	Description
Device	Indicates the list of sensors to test (TCL_HOME, IE_LOCKED, IE_CLOSED, LGR_TOUCH, LGR_P_RIGHT, LGR_P_HOME, LGR_R_RIGHT, LGR_R_MID, LGR_R_HOME, Y_HOME, X_HOME_BOT, X_HOME_TOP, TCL_SENSORS, LGR_SENSORS, LSC_SENSORS)
Accept	Y to accept changes N to reject changes <i>If Y is selected, the Response Screen appears. See Figure 4-224. Otherwise, the changed parameters continue to display but no action is taken.</i>

```
Device:All Sensors
Number:01 <
Result:Passed
                Accept: N
```

Figure 4-224 Response Dialog

Parameters	Description
Results	Passed indicates that the test executed successfully Failed indicates that the test did not execute successfully
Accept	Y to accept changes N to reject changes

Real Time

Path: **Main Menu ▶ Service ▶ Diags ▶ DI/DO ▶ Sensors ▶ Real Time**

Use Real Time to select a sensor to test and to view the sensors state changes in real time. See Figure 4-225.

```
Device: LSC SENSORS<
Number: 01
Result:
Accept: N
```

Figure 4-225 Real Time Screen

Parameters	Description
Device	Indicates the list of sensors to test (LSC SENSORS, TCL SENSORS, I/E SENSORS, LGR SENSORS, LMC SENSORS)
Number	Location of the sensor (01–14)
Accept	Y to accept changes N to reject changes

If Y is selected, the selected sensor response screen appears. See Figure 4-226 through Figure 4-232 on page 4-150.

```
OP_DOOR = 0 ANY_DOOR= 0
X_HOME_TOP= 0
X_HOME_BOTTOM= 0
Y_HOME= 0
```

Figure 4-226 LSC SENSORS Real Time Results (LMC 6)

```
SV_DOOR = 0 ANY_DOOR= 0
X_HOME_TOP= 0
X_HOME_BOTTOM= 0
Y_HOME= 0
```

Figure 4-227 LSC SENSORS Real Time Results (LMC 4)

Parameters	Description
OP_DOOR	0 indicates an ON state 1 indicates an OFF state
ANY_DOOR	0 indicates an ON state 1 indicates an OFF state
SV_DOOR	0 indicates an ON state 1 indicates an OFF state
X_HOME_TOP	0 indicates an ON state 1 indicates an OFF state
X-HOME-BOTTOM	0 indicates an ON state 1 indicates an OFF state
Y-HOME	0 indicates an ON state 1 indicates an OFF state

```
T_HOME= 0
T_DOOR_OPEN= 0
```

Figure 4-228 TCL SENSORS Real Time Results

Parameters	Description
T_HOME	0 indicates an ON state 1 indicates an OFF state
T_DOOR_OPEN	0 indicates an ON state 1 indicates an OFF state

```
IE_LOCKED = 0
IE_CLOSED = 0
```

Figure 4-229 I/E SENSORS Real Time Results

Parameters	Description
IE_LOCKED	0 indicates an ON state 1 indicates an OFF state
IE_CLOSED	0 indicates an ON state 1 indicates an OFF state

```
G_HOME = 1 R_MID= 0
G_TOUCH= 0 R_RIGHT= 0
P_HOME = 1
P_RIGHT= 0
```

Figure 4-230 LGR SENSORS Real Time Results

Parameters	Description
G_HOME	0 indicates an ON state 1 indicates an OFF state
G_TOUCH	0 indicates an ON state 1 indicates an OFF state
P_HOME	0 indicates an ON state 1 indicates an OFF state
P_RIGHT	0 indicates an ON state 1 indicates an OFF state
R_MID	0 indicates an ON state 1 indicates an OFF state
R_RIGHT	0 indicates an ON state 1 indicates an OFF state

```
SV_DOOR = 0 ANY_DOOR= 0
```

Figure 4-231 LMC 6 SENSORS Real Time Results

Parameters	Description
SV_DOOR	0 indicates an ON state 1 indicates an OFF state
ANY_DOOR	0 indicates an ON state 1 indicates an OFF state

```
SV_DOOR = 0 OP_DOOR= 0
```

Figure 4-232 LMC 4 SENSORS Real Time Results

Parameters	Description
SV_DOOR	0 indicates an ON state 1 indicates an OFF state
OP_DOOR	0 indicates an ON state 1 indicates an OFF state

Locks Dialog

Path: Main Menu ► Service ► Diags ► DI/DO ► Locks

Use the Locks dialog to exercise the I/E station lock without having to open and close the I/E station.
See Figure 4-233.



If media removal has been prevented by the host, the I/E station cannot be unlocked.

```
IE Station:01<
State:Unlocked

[toggle]
```

Figure 4-233 Locks Dialog

Parameters	Description
IE Station	I/E Station number (01–04)
State	Locked indicates that the Insert/Eject station is locked Unlocked indicates that the Insert/Eject station is unlocked

Self Test Dialog

Path: Main Menu ► Service ► Diags ► Self Test

Use the Self Test Dialog to run a predetermined sequence of diagnostics and exercisers. See Figure 4-234.

```
The self test runs
a sequence of diags.
Cycles to run:009<
Accept: N
```

Figure 4-234 Self \Test Dialog

Parameters	Description
Cycles to Run	Indicates the desired cycle count (001–999)
Accept	Y to accept changes N to reject changes

If Y is selected, the Response Dialog appears. See Figure 4-235. Otherwise, the changed parameters continue to display but no action is taken.

```
DIAGS SELF TEST
Cycle :006 of 009
Status:Running
Cancel: N<
```

Figure 4-235 Response Dialog

Parameters	Description
Cycle	The number of completed test cycles of the requested cycles
Status	Shows the status of the indicated cycle (Running, Completed, Error, Canceled)
Cancel	Y to cancel the test N to continue running the test

If Y is selected for the Cancel parameter value, the test is canceled. Otherwise, the test continues.

 **Note**
If the operation stops, the **Cancel** parameter no longer displays.

P/S Submenu

Path: **Main Menu ▶ Service ▶ Diags ▶ P/S**

Use the P/S Submenu to test the Library and universal drive sled (UDS) power supplies. See Figure 4-236.

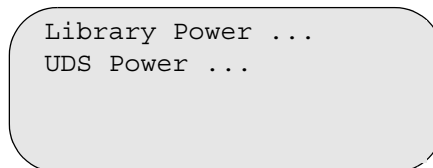

Figure 4-236 P/S Submenu

Library Power

Path: **Main Menu ▶ Service ▶ Diags ▶ P/S ▶ Library Power**

Use Library Power to test the installed DC power supply status with respect to AC input and DC output. The function indicates whether the power supplies are functioning properly. See Figure 4-237.

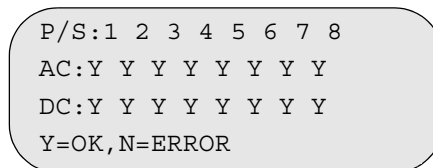

Figure 4-237 Library Power

Parameters	Description
P/S	Power supply selected for test.
AC	AC power output. Y = Test Ok N = Test error
DC	DC power supply output Y = Test Ok N = Test error

UDS Power

Path: **Main Menu** ► **Service** ► **Diags** ► **P/S** ► **UDS Power**

Use UDS Power to view the status of the installed UDS power supplies. See Figure 4-238.

```
P/S: B1 B2 B3 B4
DC : Y  Y  Y  Y
Dual: Y  Y  Y  Y
Rack: 04
```

Figure 4-238 UDS Power Status Screen

Parameters	Description
P/S	Drive bay power supply
DC	DC output from at least one power supply Y= Status Ok N= No DC output - = Drive bay not present x = Invalid power supply
Dual	There are two power supplies to provide power supply redundancy Y= Both power supplies are functioning normally N= One or both power supplies failed - = Drive bay not present x = Invalid power supply
Rack	Rack number. Only racks that contain UDS drives (CM, DM) are displayed

Library Submenu

Path: Main Menu ► Service ► Diags ► Library

Use the Library Submenu to perform move tests. See Figure 4-239.

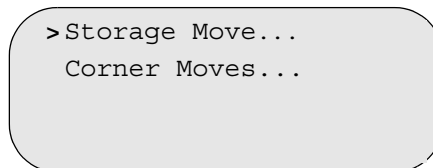

Figure 4-239 Library Submenu

Storage Move

Path: Main Menu ► Service ► Diags ► Library ► Storage Move

Use Storage Moves to move a cartridge through every storage cell in a given range. The cartridge is moved to or from the I/E station and then to the specified cells. This test requires a service-level password. After a password is provided, the system prompts for the I/E station where the source cartridge is located. Then, the system prompts for the beginning and ending storage location. The test can be cancelled at any. See Figure 4-240.

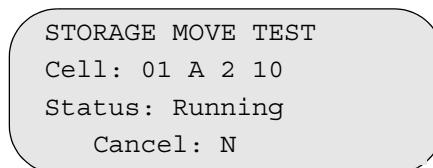



Figure 4-240 Storage Moves Dialog

Parameters	Description
Cell	Beginning and ending storage locations
Status	Shows the status of the test (Running, Canceled)
Cancel	Y to cancel the test N to continue running the test

 **Note**
If the operation stops, the **Cancel** parameter no longer displays.

Corner Moves

Path: **Main Menu ▶ Service ▶ Diags ▶ Library ▶ Corner Moves**

Use Corner Moves to move cartridges from the I/E station to each corner of each storage section for all media types. There must be three cartridges of the same type, in a row, present in the I/E station for the test to work properly. Additionally, the test will only exercise the corners in the library that are empty. See Figure 4-241.

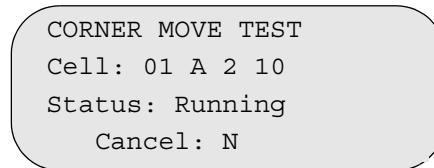

CORNER MOVE TEST
Cell: 01 A 2 10
Status: Running
Cancel: N

Figure 4-241 Corner Moves Dialog

Cell	Beginning and ending storage locations
Status	Shows the status of the test (Running, Canceled)
Cancel	Y to cancel the test N to continue running the test

 **Note**
If the operation stops, the **Cancel** parameter no longer displays.

Teach Submenu

Path: **Main Menu ► Service ► Teach**

Use the Teach Submenu to reset and re initialize the library configuration. See Figure 4-242.

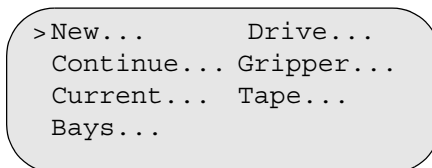

Figure 4-242 Teach Submenu

Depending on your selection, refer to:

- *New Dialog* below
- *Continue Dialog* on page 4-158
- *Current Dialog* on page 4-159
- *Bays Dialog* on page 4-162
- *Drive Dialog* on page 4-164
- *Gripper Dialog* on page 4-166
- *Tape Dialog* on page 4-168

New Dialog

Path: **Main Menu ► Service ► Teach ► New**

Use the New Dialog to reset and re-initialize the library configuration and calibration information. All previous information is destroyed and then an inventory is automatically performed. See Figure 4-243.

 **Note**
The New operation clears all cell statistics.

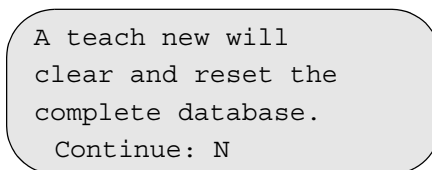
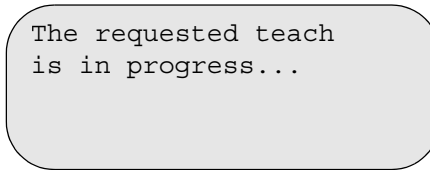

Figure 4-243 Teach New Dialog

Parameters	Description
Continue	Y to continue the teach new N to return to the previous submenu

If Y is selected for the Continue parameter value, the Progress Screen followed by either the Response Screen or Failed Screen appears. See Figure 4-244, Figure 4-245, and Figure 4-246.

A light gray rounded rectangular box containing the text "The requested teach is in progress...".

The requested teach
is in progress...

Figure 4-244 Progress Screen

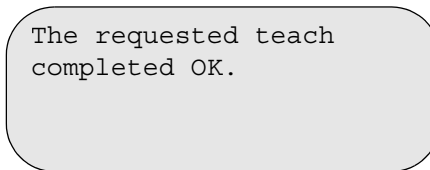
A light gray rounded rectangular box containing the text "The requested teach completed OK.".

The requested teach
completed OK.

Figure 4-245 Response Screen

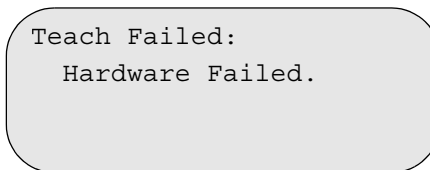
A light gray rounded rectangular box containing the text "Teach Failed: Hardware Failed.".

Teach Failed:
Hardware Failed.

Figure 4-246 Failed Screen

Continue Dialog

Path: Main Menu ► Service ► Teach ► Continue

Use the Continue dialog to resume a failed Teach New operation. See Figure 4-247.

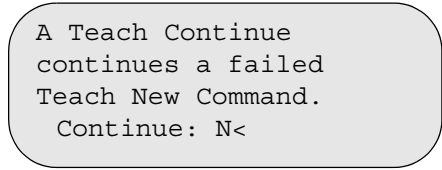

A Teach Continue
continues a failed
Teach New Command.
Continue: N<

Figure 4-247 Continue Dialog

Parameters	Description
Continue	Y to continue the teach new N to return to the previous Dialog

If Y is selected for the Continue parameter value, the Progress Screen appears followed by either the Response Screen or Failed Screen. See Figure 4-248 on page 4-158, Figure 4-249 on page 4-158, and Figure 4-250 on page 4-159.

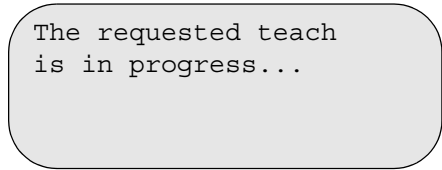

The requested teach
is in progress...

Figure 4-248 Progress Screen

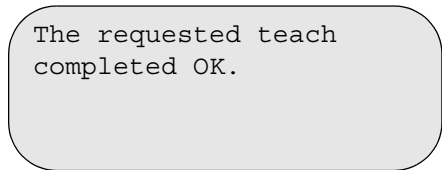

The requested teach
completed OK.

Figure 4-249 Response Screen

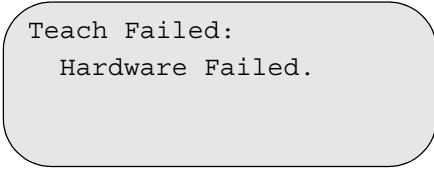

Teach Failed:
Hardware Failed.

Figure 4-250 Failed Screen

Current Dialog

Path: **Main Menu ▶ Service ▶ Teach ▶ Current**

Use the Current Dialog to re-calibrate the library coordinate information. All previous configuration and inventory information is retained. See Figure 4-251.

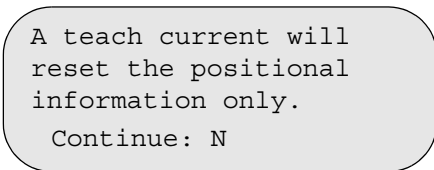

A teach current will
reset the positional
information only.
Continue: N

Figure 4-251 Teach Current Dialog

 **Note**
Teach Bays removes drives which have been previously varied off and removed from the library configuration.

Parameters	Description
Continue	Y to continue the teach current N to return to the previous Dialog

If Y is selected for the Continue parameter value, the Starting and Ending Dialog appears. See Figure 4-252.

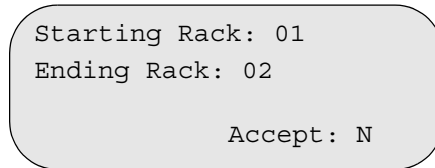

Figure 4-252 Starting and Ending Dialog

Parameters	Description
Starting Rack	Indicates which rack to begin the Teach Current operation. (1-16 depending on the number of expansion modules)
Ending Rack	Indicates which rack to end the Teach Current operation. (1-16 depending on the number of expansion modules)
Accept	Y to accept changes N to reject changes

If Y is selected, the Progress Screen appears followed by either the Response Screen or Failed Screen. See Figure 4-253 on page 4-160, Figure 4-254 on page 4-161, and Figure 4-255 on page 4-161.

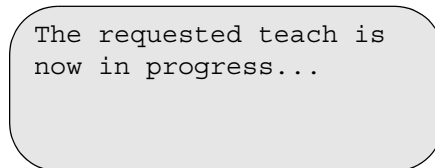
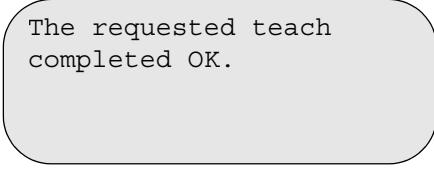
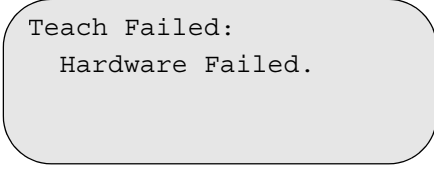

Figure 4-253 Progress Screen

A light gray rounded rectangular box containing the text "The requested teach completed OK." in a monospaced font.

The requested teach
completed OK.

Figure 4-254 Response Screen

A light gray rounded rectangular box containing the text "Teach Failed:
Hardware Failed." in a monospaced font.

Teach Failed:
Hardware Failed.

Figure 4-255 Failed Screen

Bays Dialog

Path: Main Menu ► Service ► Teach ► Bays

Use the Bays Dialog to reteach drive locations in a specified rack. See Figure 4-256.

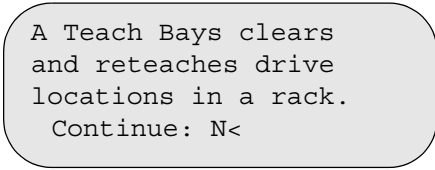

A Teach Bays clears
and reteaches drive
locations in a rack.
Continue: N<

Figure 4-256 Bays Dialog

 **Note**
Teach Bays
removes drives
which have been
previously varied
off and removed
from the library
configuration.

Parameters	Description
Continue	Y to continue the teach new N to return to the previous Dialog

If Y is selected for the Continue parameter value, Continue Dialog appears. See Figure 4-257. When you choose Accept, the Progress Screen appears followed by either the Response Screen or Failed screen. See Figure 4-258 on page 4-162, Figure 4-259 on page 4-163, and Figure 4-259 on page 4-163.

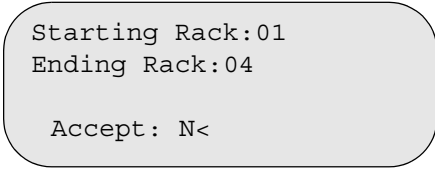

Starting Rack:01
Ending Rack:04

Accept: N<

Figure 4-257 Continue Dialog

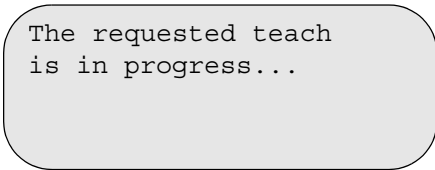

The requested teach
is in progress...

Figure 4-258 Progress Screen

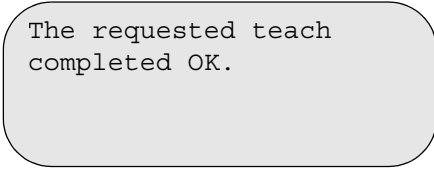
A light gray rounded rectangular box containing the text "The requested teach completed OK." in a monospaced font.

The requested teach
completed OK.

Figure 4-259 Response Screen

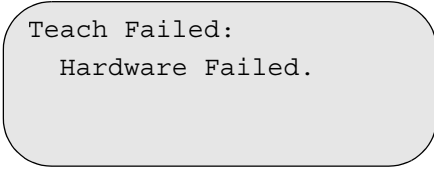
A light gray rounded rectangular box containing the text "Teach Failed:
Hardware Failed." in a monospaced font.

Teach Failed:
Hardware Failed.

Figure 4-260 Failed Screen

Drive Dialog

Path: Main Menu ► Service ► Teach ► Drive

Use the Drive Dialog to clear and reteach a drive location. See Figure 4-261.

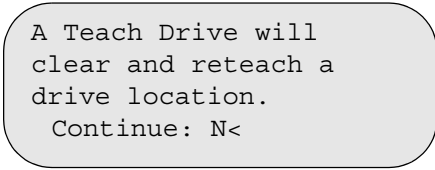

```
A Teach Drive will  
clear and reteach a  
drive location.  
Continue: N<
```

Figure 4-261 Drive Dialog

Parameters	Description
Continue	Y to continue the teach new N to return to the previous Dialog

If Y is selected for the Continue parameter value, Continuation Screen appears. See Figure 4-262 on page 4-164. When you choose Accept, the Progress Screen appears followed by either the Response Screen or Failed Screen. See Figure 4-263 on page 4-164, Figure 4-264 on page 4-165, and Figure 4-264 on page 4-165.

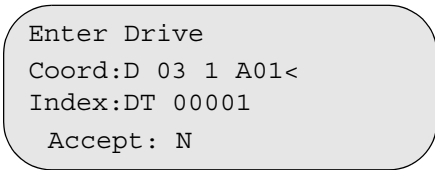

```
Enter Drive  
Coord:D 03 1 A01<  
Index:DT 00001  
Accept: N
```

Figure 4-262 Continuation Screen

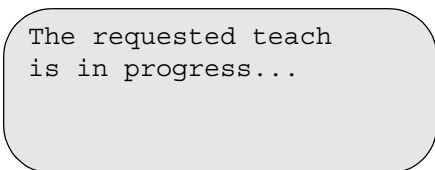

```
The requested teach  
is in progress...
```

Figure 4-263 Progress Screen

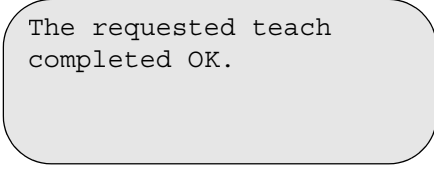
A light gray rounded rectangular box containing the text "The requested teach completed OK." in a monospaced font.

The requested teach
completed OK.

Figure 4-264 Response Screen

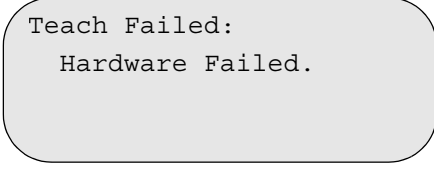
A light gray rounded rectangular box containing the text "Teach Failed:
Hardware Failed." in a monospaced font.

Teach Failed:
Hardware Failed.

Figure 4-265 Failed Screen

 **Note**
Perform a teach gripper after replacing the gripper FRU. If a teach gripper is only marginally successful, the library will post a message advising you to perform a teach current.

Gripper Dialog

Path: **Main Menu ▶ Service ▶ Teach ▶ Gripper**

Use the Gripper Dialog to reteach the gripper to match the scanner geometry. See Figure 4-266.

A Teach Gripper will reteach the gripper to scanner geometry.
Continue: N<

Figure 4-266 Gripper Dialog

Parameters	Description
Continue	Y to continue the teach new. N to return to the previous Dialog

*If **Y** is selected for the Continue parameter value, the Progress Screen appears followed by either the Response Screen, Teach Marginal screen, or the Failed screen. See Figure 4-267, Figure 4-268, Figure 4-269, or Figure 4-270.*

The requested teach is in progress...

Figure 4-267 Progress Screen

The requested teach completed OK.

Figure 4-268 Response Screen

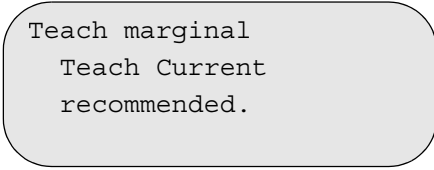
A light gray rounded rectangular box containing the text:

Teach marginal
Teach Current
recommended.

Figure 4-269 Teach Marginal Screen

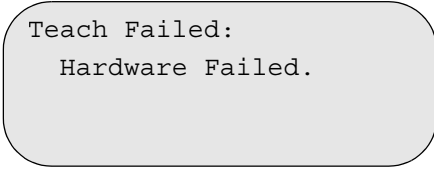
A light gray rounded rectangular box containing the text:

Teach Failed:
Hardware Failed.

Figure 4-270 Failed Screen

Tape Dialog

Path: **Main Menu ▶ Service ▶ Teach ▶ Tape**

Use the Tape Dialog to refine teach positions and improve get and put functions for LTO linear storage. This feature is for Quantum use only. See Figure 4-271.

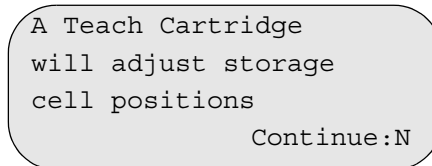

```
A Teach Cartridge
will adjust storage
cell positions
Continue:N
```

Figure 4-271 Teach Tape Dialog

Refer to *Teach Tape Instructions*, 6-01319-01, for information on how to perform a Teach Tape.

SAC Dialog

Path: **Main Menu ▶ Service ▶ SAC**

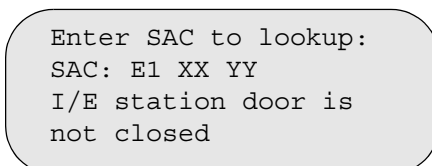

Use the SAC Dialog to see an explanation of the displayed Service Action Code (SAC). See Figure 4-272.



```
Enter SAC to lookup:
SAC: E1 XX YY
I/E station door is
not closed
```

Figure 4-272 SAC Dialog

Note

Press the  button or the  button to scroll between SAC values.

For additional information on the SACs, refer to *Service Action Codes* on page 6-11.

Demo Dialog

Path: **Main Menu ▶ Service ▶ Demo**

 **Note**
At least one storage element for each media type must be empty for the Demo to run.

Use the Demo Dialog to move cartridges randomly from storage element to storage element. You can also select Demo to move cartridges to tape drives. See Figure 4-273 and Figure 4-274.

```
Enter password:
[0000]
^
Accept: N
```

Figure 4-273 Enter Password Dialog



Caution

If your library is host partitioned, do not use the operator panel to move a cartridge. The library does not know the partition limits and could move a cartridge outside of the partitioned area, making that cartridge inaccessible to the host.

```
Demo will randomly
move the media.
Moves:      001<
Accept: N
```

Figure 4-274 Demo Dialog

 **Note**
The Demo is limited to 100 moves.

Parameters	Description
Moves	Indicates the desired cartridge move (001–100)
Accept	Y to accept changes N to reject changes

If Y is selected for the Accept parameter, the Include Drives Dialog appears. See Figure 4-275 on page 4-170. Otherwise, the changed parameters continue to display but no action is taken.

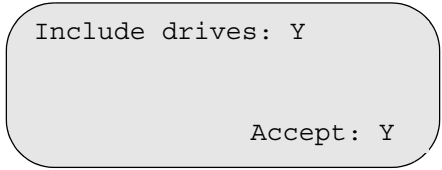



Figure 4-275 Include Drives Dialog

 **Note**
 The Demo feature does not work with 3590 drives. If your library contains 3590 drives, do not include drives in the Demo.

Parameters	Description
Include Drives	Y indicates that the drives are included in the moving of the cartridges N indicates that the drives are not included in the moving of the cartridges
Accept	Y to accept the changed N to reject the changes

If Y is selected, the Response Dialog appears. See Figure 4-276. Otherwise, the changed parameters continue to display but no action is taken.

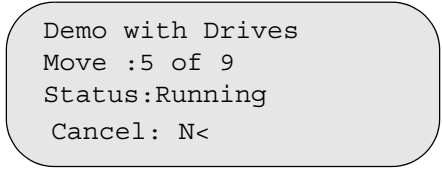



Figure 4-276 Response Dialog

 **Note**
 If the operation stops, the **Cancel** parameter no longer displays.

Parameters	Description
Cancel	Y to cancel the test N to continue running the test

The value of the Move parameter in the Response Dialog is supplied by the library firmware and cannot be changed. The Move parameter indicates the number of completed moves.



The value of the Status parameter in the Response Dialog is supplied by the library firmware and cannot be changed. The Status parameter shows the status of the indicated move (Running, Completed, Error, Canceled).

If Y is selected for the Cancel parameter value, the test is canceled. Otherwise, the test continues.

Verify Submenu

Path: **Main Menu ▶ Service ▶ Verify**

Use the Verify Dialog to perform and get a report of the installation verification test. See Figure 4-277.

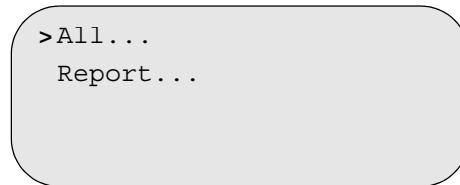

Figure 4-277 Verify Submenu

Depending on your selection, refer to:

- *All Dialog* on page 4-171
- *Report Dialog* on page 4-172

All Dialog

Path: **Main Menu ▶ Service ▶ Verify ▶ All**

This is for Quantum use only.

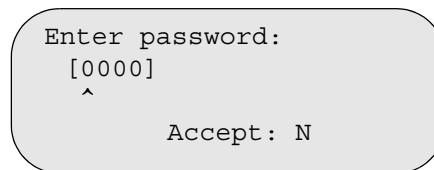

Figure 4-278 All Dialog

Report Dialog

Path: **Main Menu ▶ Service ▶ Verify ▶ Report**

Use the Report Dialog to generate a print of the installation verification test. See Figure 4-279.

Before selecting this option, make sure that a serial print cable is connected to a serial port, before you generate a print.

When the Report is selected, the Report Screen is displayed. See Figure 4-279.

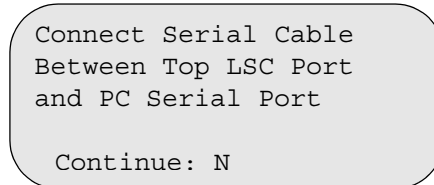

```
Connect Serial Cable  
Between Top LSC Port  
and PC Serial Port  
  
Continue: N
```

Figure 4-279 Report Screen

If Y is selected for the Continue parameter value, the Response Screen appears. See Figure 4-279. Otherwise, the changed parameter continues to display but no action is taken.

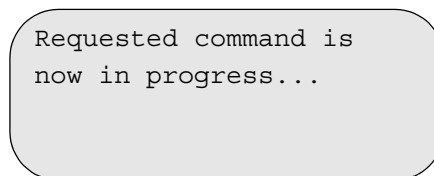

```
Requested command is  
now in progress...
```

Figure 4-280 Response Screen

Advanced Submenu

Path: **Main Menu ▶ Service ▶ Advanced**

For Quantum use only.



```
>Status ▶  
Mounts...  
Other...
```

Figure 4-281 Advanced Submenu

About Screen

Path: **Main Menu ▶ About**

The About Screen displays your library firmware information (embedded software). For example, version and serial number. See Figure 4-282.

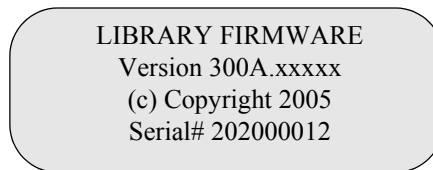
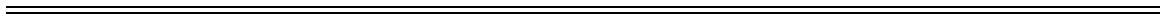

Figure 4-282 About Screen

Parameter	Description
Version	Displays the current version of the library firmware (library controller firmware only).



5

Processing Media

Overview	5-3
Tape Cartridge Maintenance	5-3
Inspecting Tape Cartridges	5-3
Handling Tape Cartridges	5-4
Storing Tape Cartridges	5-4
Acclimating Tape Cartridges	5-5
Transporting Tape Cartridges	5-5
Inserting Tape Cartridges	5-6
Inserting Tape Cartridges Using the Insert/Eject Station	5-6
Manually Bulk Loading Tape Cartridges	5-7
Standard Bulk Loading	5-7
TM Bulk Loading	5-7
Ejecting Tape Cartridges	5-11
Understanding Barcodes	5-12
Barcode Labels	5-12
Applying Labels	5-13
Barcode Label Restrictions	5-14
Cleaning Drives	5-16
Typical Cleaning Operation	5-16
Non-typical Cleaning	5-16
Inserting and Ejecting Cleaning Cartridges	5-17
Insert a Cleaning Cartridge	5-19
Eject a Cleaning Cartridge	5-21
AutoClean	5-22

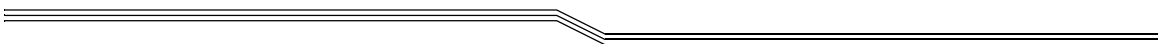

Overview

This chapter includes information on processing media and is organized as follows:

- *Tape Cartridge Maintenance* below
- *Inserting Tape Cartridges* on page 5-6
- *Ejecting Tape Cartridges* on page 5-11
- *Understanding Barcodes* on page 5-12
- *Cleaning Drives* on page 5-16

Tape Cartridge Maintenance

The library uses magnetic tape cartridge technology to collect, backup, and archive data. Magnetic tape is made of flexible plastic that is coated with ferromagnetic material on one side. Simple care and handling will protect your cartridges.

Tape cartridges can survive years of use in a library environment, but cartridges wear out over time. Worn media can also cause damage to drives and potentially lead to a loss of data. Refer to the media manufacturer's specifications for tape cartridge life.

To reduce the chance of problems with your tape cartridges or damage to your tape drive, follow these guidelines:

- *Inspecting Tape Cartridges* below
- *Handling Tape Cartridges* on page 5-4
- *Storing Tape Cartridges* on page 5-4
- *Acclimating Tape Cartridges* on page 5-5
- *Transporting Tape Cartridges* on page 5-5

Inspecting Tape Cartridges

Before inserting new cartridges into the library, inspect them for damage caused by shipping or mishandling. For specific instructions about data recovery when media has been damaged, refer to the drive or tape cartridge manufacturer's specifications.

Inspect tape cartridges in the following situations:

- If a cartridge has been dropped from a height greater than three feet.
- If the tape drive becomes inoperable after loading a tape cartridge.
- If the cartridge has been stored in a dusty environment without a case.

Do not use the tape cartridges in the following situations:

- If there is condensation in or on the tape cartridge.
- If the cartridge has cracks or other physical damage.
- If the cartridge casing is split at the seams.
- If the leader pin is broken, loose, or dislodged from its housing.

Handling Tape Cartridges

The Scalar 10K provides extra IE station magazines and dust covers for storing and handling purposes. This allows for easy removing, handling, storing, and inserting of cartridges to and from the library without library disruption.

Use the following tips when handling cartridges:

- Remove dust on the outside of the cartridges with a damp cloth.
- Do not touch the tape leader.
- Do not expose cartridges to moisture or direct sunlight.
- Do not expose cartridges to magnetic fields.
- Avoid unnecessary opening of the cartridge door because this can expose the cartridge to contamination or physical damage.
- Do not drop cartridges or subject cartridges to physical shock.

Storing Tape Cartridges

Use the following tips when storing cartridges:

- While cartridges are not in the library, store them in either their protective cases, the IE station magazines with dust covers, or in individual protective cases.
- The storage environment should not exceed temperature and humidity requirements as described in the drive manufacturer specifications.

-
-
- When tape cartridges are stored in an extended archival environment, always orient the cases so that the reel axis is horizontal. Use protective cases if storage containers are accommodating.
 - Never stack cartridges in a stack of more than five.
 - Do not place cartridges on or near devices that may produce magnetic fields such computer monitors or motors. Such exposure can alter or erase data on the cartridge.

Acclimating Tape Cartridges

When media is introduced to a new environment, the media must acclimate to the new environment prior to usage.

- Unpack media if in shipping containers and allow media to acclimate to new environment for 24 hours in protective cases.
- Make sure that there is not any condensation in or on the tape cartridge.
- Make sure that the environmental temperature and humidity is within levels specified per the tape drive specifications.

Transporting Tape Cartridges

The following tips will help you move your tapes from one location to another:

- If you are shipping tape cartridges, ship them in a jewel case or equivalent.
- Place cartridges in plastic wrap to protect them from moisture, dust, and other contaminants.
- When carrying cartridges or shipping them, always orient the cases so that the reel axis is horizontal within the case and shipping box.
- Pack cartridges snugly so that the cartridges do not rattle around.
- Use a rigid box surrounded by adequate shock-absorbent material.
- Clearly mark the box with the proper orientation.

Inserting Tape Cartridges

Use the Insert/Eject (I/E) station to insert tape cartridges into the library. You can also manually bulk load cartridges directly into an aisle.

Inserting Tape Cartridges Using the Insert/Eject Station

When using the I/E Station to insert tape cartridges, library operations are not disrupted. Proceed as follows to insert cartridges through the I/E station:

Step 1 Remove an I/E magazine from the I/E station.

Step 2 Insert the cartridges into the I/E magazine.

Step 3 Place the I/E magazine back into the I/E station.

The library locks the I/E station. The accessor scans the I/E station for new cartridges, then the library unlocks the I/E station.

Step 4 Move the cartridge to the desired storage cell with the **SCSI MOVE MEDIUM** command from the host application.

— or —

Issue the **Insert** command from the operator panel. Refer to *Insert Screen* on page 4-52.

The Accessor moves all cartridges from the I/E station to storage cell locations, beginning with the first available storage cell location.

Manually Bulk Loading Tape Cartridges

You can manually bulk load tape cartridges directly into licensed storage locations (cells). This process is faster than loading a few cartridges at a time through the I/E station and is the normal process for loading a new library.

Warning

Movements of mechanical components in the library can cause serious injury. Make sure that all power to the library is off before entering the library through the access door.

Note

Make sure to bulk load cartridges only in licensed storage locations.

Note

Use the Expansion Module access door to reach additional cartridge storage locations.

Standard Bulk Loading

Proceed as follows to bulk load your library:

- Step 1** Shut down the main library power.
- Step 2** Enter the aisle through the service door on the AM.
- Step 3** Load the cartridges, starting with rack 1 and continuing through each rack in succession (for example rack 2, rack 3, rack 4), until you have reached the limit of your licensed storage.
- Step 4** When you have completed your bulk load, make sure the aisle is free of obstructions and the service and access doors are closed.
- Step 5** Turn on the library power and inventory the library.

TM Bulk Loading

Proceed as follows to bulk load an outside Tower Module (TM):

- Step 1** Set the TM that you are going to bulk load to **USER Mode (Main Menu ► Utils ► Towers ► Status Change)**. See Figure 5-1 on page 5-7.

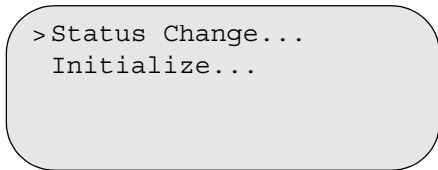

```
>Status Change...  
Initialize...
```

Figure 5-1 Towers Submenu

Step 2 Select **Status** Change.

The Set Status Dialog appears. See Figure 5-2.

```
Tower : 01 LTO <
Mode : LIBRARY
State : READY
      Accept : N
```

Figure 5-2 Set Status Dialog

Step 3 Select the TM to change.

Step 4 Change the Mode field to **USER**.

The State automatically changes to NOT READY.

Step 5 Change Accept to **Y**.

TOWER MODE CHANGE appears. See Figure 5-3.

```
TOWER MODE CHANGE
This selection will
prevent host access.
      Continue: N <
```

Figure 5-3 Tower Mode Change

Step 6 Change Continue to **Y**.

The tower changes the State to NOT READY.

```
Tower : 01 LTO <
Mode : USER
State : NOT READY
      Accept : N
```

Figure 5-4 Set Status Dialog

Step 7 Open the TM service door.

Step 8 Grasp the tower firmly at the top of the columns or where the racks are joined (where the sheet metal is visible) to rotate to the column that you want to load.

 **Note**
Use two hands to manually rotate the tower.

Step 9 Continue bulk loading your cartridges.

When your bulk load completes, proceed as follows:

Step 1 Close the TM service door.

Step 2 Set the Mode field to **LIBRARY**.
See Figure 5-5.

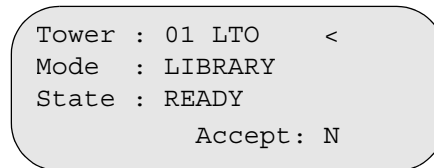

```
Tower : 01 LTO <
Mode  : LIBRARY
State : READY
      Accept: N
```

Figure 5-5 Set Status Dialog

*If Y is selected for the Accept parameter value, Tower Mode Change in Progress appears. See Figure 5-6.
If N is selected for the Accept parameter value, the display returns to USER mode and no action is taken.*

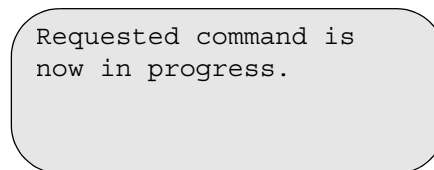

```
Requested command is
now in progress.
```

Figure 5-6 Tower Mode Change In Progress

Step 3 Inventory Tower screen appears when the requested command completes. See Figure 5-7.

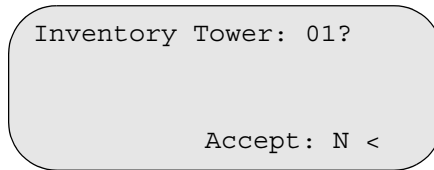

Inventory Tower: 01?

Accept: N <

Figure 5-7 Inventory Tower

If Y is selected for the Accept parameter value, Tower Inventory In Progress appears. See Figure 5-8 on page 5-10. If N is selected for the Accept parameter value, Requested Command Complete appears and no action is taken. See Figure 5-9 on page 5-10.

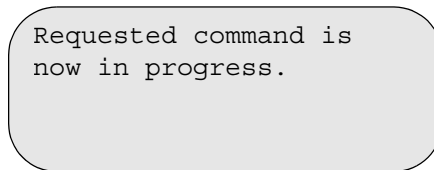

Requested command is
now in progress.

Figure 5-8 Tower Inventory In Progress

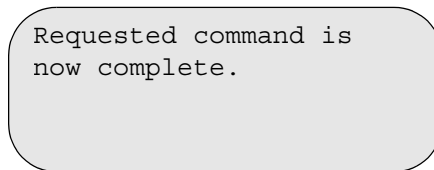

Requested command is
now complete.

Figure 5-9 Requested Command Complete

Ejecting Tape Cartridges

Use the I/E station to remove tape cartridges from the library. Using the I/E station to remove cartridges does not disrupt library operations.

To remove tape cartridges from the library, do the following:

Step 1 Issue a SCSI **MOVE MEDIUM** command from the host with the source storage cell and the destination I/E cell.

— or —

Execute the **Eject** command from the operator panel. Refer to *Eject Dialog* on page 4-56.

The library locks the I/E station, puts cartridges in the the I/E station, then unlocks the I/E station.

Step 2 Wait until the I/E station lock light is off, then rotate the I/E station door open and remove the I/E magazine, or cartridges from the I/E station.

Step 3 Put the I/E magazine into the I/E station if you removed it in the previous step.

Step 4 Rotate the I/E station door closed. The door locks and the accessor scans the I/E station.

Understanding Barcodes

Each tape cartridge in the Scalar 10K must have an external label that is operator and machine readable to identify the barcode number. A barcode must use only uppercase letters A to Z and/or numeric values 0 to 9. The Scalar 10K currently supports Code 39 type barcode labels.

Note

The 6 character 8 mm barcode labels contain a seventh character checksum that is reported as A in MIXED media mode and interpreted as part of the barcode in EXTENDED mode. The seventh character is ignored in DEFAULT media mode.

The labels may have five to sixteen characters (library in EXTENDED media mode), or six characters plus a possible media identifier character (library in DEFAULT media mode), or six characters with an additional media identifier character (library in mixed-media mode).

An additional seventh or eighth character may be used to identify the cartridge type. The cartridge type is a separate single character that follows the barcode label or a single character that is included with the six character barcode. The two additional characters, for example L1, identifies LTO cartridges.

Barcode Labels

For customers who want to print the barcode labels, the individual media labels are supported if the labels meet the ANSI MH10.8M-1983 standard and other additional requirements. The requirements are:

- ANSI MH10.8M-1983 Standard
 - Number of digits:
 - five to sixteen in extended mode
 - six (up to eight including media characters) in default and mixed media mode
 - Background reflection: at least 25 percent
 - Print contrast: at least 75 percent
 - Ratio: at least 2.2
 - Module: 250 mm
 - Print tolerance: ± 57 mm
- Additional Requirements
 - Length of the rest zones: $5.25 \text{ mm} \pm 0.25 \text{ mm}$
 - No black marks can be present in the intermediate spaces or rest zones.
 - No white areas may be present on the bars.
 - A nine digit barcode must not match the serial number of the unit, otherwise it is ignored.

- Bars should read in a uniform direction. Nonuniform reading directions are feasible in principle, but have a detrimental effect on performance.
- Each label should be applied in the upper right corner of the tape cartridge recess (when oriented vertically).

- Quality Testing

Compliance with these specifications can be checked and documented with the Ergilaser 3000 High Density barcode measuring device that is manufactured by the Laetus Company.

Applying Labels

All barcode labels are applied to the front of a tape cartridge. Depending on the media type, barcode labels are either stickers that adhere to the front of the cartridge or are cutouts that slide into an indentation on the front of the cartridge.

See Figure 5-10 on page 5-13 for more information on applying a barcode label.



Caution

Do not place a barcode label on top of a cartridge. Placing a barcode label on top of a cartridge can cause a library inventory operation to fail.

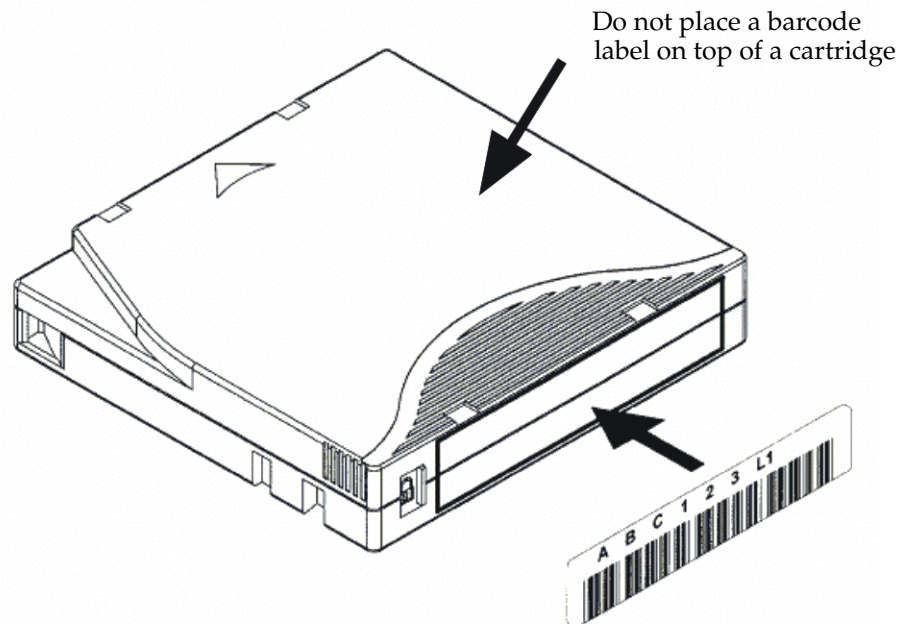

Figure 5-10 Barcode Label Application (LTO Example)

Barcode Label Restrictions

Note
Duplicate barcodes are not supported even if different media labels are used.

The Scalar 10K supports a range of media labels. With mixed media enabled, some additional restrictions apply.

All labels are restricted to sixteen character (in extended mode) and six character (in default and mixed media mode) barcodes. In default and mixed media mode, for specific SDLT media labels which contain an embedded seventh or eighth character in the label, the additional characters are stripped off by firmware. AIT (8 mm) labels contain an embedded checksum character that, in default and mixed media mode, is stripped off by the firmware. In extended mode, all media characters, and checksums are saved. For examples of supported barcode labels, see Figure 5-11.

Apply the label so that the characters are on top and the barcode is on the bottom.

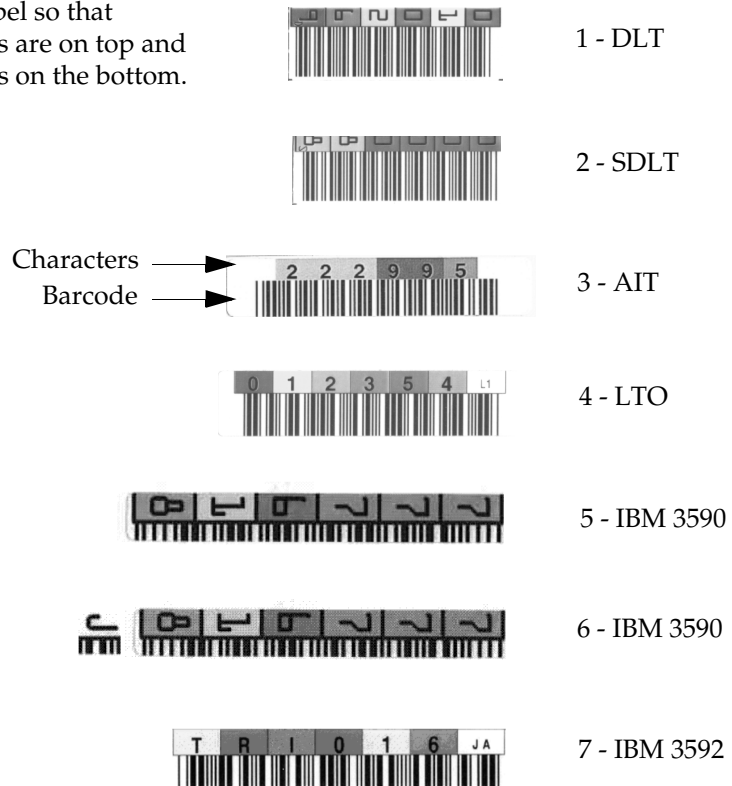

Figure 5-11 Barcode Label Examples

In Figure 5-11 on page 5-14, the numeric listing above each label type identifies the restriction associated with the label.

- 1 This is a six-character Code 39 forward printed label for a DLT cartridge. The Scalar 10K supports only CompacTape IV DLT cartridges.
- 2 This is a six character Code 39 forward printed label for a SDLT cartridge.
- 3 This is a six character forward printed label for an 8 mm cartridge.
- 4 This is a six character Code 39 backward printed label. The embedded additional seventh and eighth characters identify the LTO cartridge media type.
- 5 This is a six character Tri-Optic forward printed label for a IBM 3590 cartridge. This label can be used only when media ID is disabled.
- 6 This is a six character Tri-Optic forward printed label with one additional character media identifier for a IBM 3590 cartridge. This label can be used in both media ID enabled and media ID disabled applications.
- 7 This is a six character Code 39 backward printed label. The embedded additional seventh and eighth characters identify the 3592 cartridge media type.

Cleaning Drives

Note

Cleaning cartridges have white labels and the first three letters for the Volser number are CLN.

Most tape drives require occasional cleaning. The cleaning cartridge cleans accumulated debris from the tape drive and the read/write head.

Listed below are three methods for cleaning cartridge drives:

- Host application software (default)
- Scalar 10K firmware (selected from the operator panel)
- Manual operation (performed by the operator)

Typical Cleaning Operation

Note

Be aware that most cleaning cartridges are abrasive and burnish the heads of the drive they are cleaning. Burnishing causes wear on the tape drive heads. Cleaning too frequently can reduce the life of a tape drive.

Typically during normal operation, the host system moves the data cartridges to and from drives.

During a move from a drive to a storage location in the library, the application checks drive status. If the drive reports that it requires cleaning, the system puts the cartridge it is moving into storage, but does not notify the host that the move is complete.

The system selects the cleaning cartridge, and inserts it into the drive. After the cleaning is complete, the cartridge is ejected from the tape drive and moved back to storage. The library reports to the host that the move is complete.

Non-typical Cleaning

Listed below are several instances when a typical cleaning operation cannot be performed.

Note

To avoid this event, adjust the system wait time. If the system wait time cannot be adjusted to allow cleaning to complete, clean the drive manually or use the library firmware.

- Drive cleaning takes several minutes to complete. If the host system does not wait for the cleaning to complete, it reports an error.
- If the library is set to delayed cleaning, the library waits until a specified time before it performs the cleaning operation.
- If the drive type does not support drive communication to the library, the library cannot automatically clean the drive. The drive must be cleaned using application software.

There are common items which are used for either Scalar 10K firmware or host controlled drive cleaning. The following items refer to several operator panel menus. All menu information is detailed in *Menus and Commands* on page 4-1.

Inserting and Ejecting Cleaning Cartridges

Caution

Before cleaning a drive, make sure that a cleaning cartridge is in the library inventory, know the status of any cleaning cartridge in the library, and know how to insert or eject a cleaning cartridge.

If your library is host partitioned, do not use the operator panel to move a cartridge. The library does not know the partition limits and could move a cartridge outside of the partitioned area, making that cartridge inaccessible to the host.

Make sure that a slot is available for the cleaning cartridge and then manually insert it into the library using the I/E station and operator panel.

If the Scalar 10K library controls the cleaning operation, you cannot share a cleaning cartridge between the primary aisle and secondary aisle in a Dual Aisle configuration. You must insert the cleaning cartridge into the aisle containing the tape drive that requires cleaning. For example, if you need to clean a tape drive located in the secondary aisle, insert the cleaning cartridge using the secondary aisle I/E station and operator panel.

The following procedures use the operator panel to check cleaning cartridge status, and move cleaning cartridges in and out of the library.

Media Dialog

Use this method after you manually insert a cleaning cartridge into the library. For further information refer to *Media Dialog* on page 4-77.

Step 1 From the operator panel Main Menu, select **Setup ► Cleaning ► Media**.

The Media Dialog appears. See Figure 5-12.

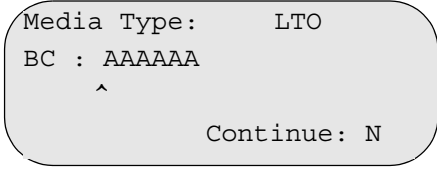

```
Media Type:      LTO
BC : AAAAAA
  ^
Continue: N
```

Figure 5-12 Media Dialog

Step 2 Enter the Media Type and BC (number of the cleaning cartridge you want to insert), and then select **Y** in the Continue field.

The Usage Dialog appears. See Figure 5-13 on page 5-18.

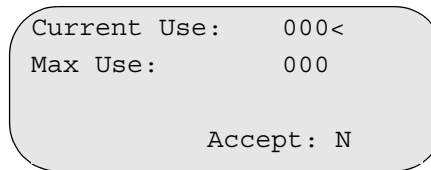
A screenshot of a dialog box with a light gray background and rounded corners. It contains the following text:

```
Current Use: 000<
Max Use: 000
Accept: N
```

Figure 5-13 Usage Dialog

Step 3 Enter Current Use (how many times the cleaning cartridge has been used), and Maximum Use (how many times the cleaning cartridge can be used), and then select **Y** in the Accept field.

View Dialog

Check to see status of your cleaning cartridges.
For further information refer to *View Dialog* on page 4-98.

Step 1 From the operator panel Main Menu, select **Setup ► Cleaning ► View**.

The View Dialog appears and displays the BC number, Status (reset, expired, missing, or valid), Max (times you can use the tape), Count (how many times the tape has been used), Index (device address). See Figure 5-14.

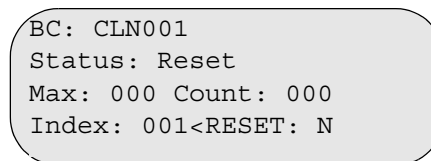
A screenshot of a dialog box with a light gray background and rounded corners. It contains the following text:

```
BC: CLN001
Status: Reset
Max: 000 Count: 000
Index: 001<RESET: N
```

Figure 5-14 View Dialog

Insert a Cleaning Cartridge

 **Note**

It is possible to use the I/E station as storage for cleaning media but is not recommended.

This procedure describes how to insert a cleaning cartridge. For more information, refer to *Insert Clean Tape Dialog* on page 4-53.

- Step 1** From the operator panel Main Menu, select **Commands ► Insert/Eject ► Insert Clean Tape**.

The Insert Clean Tape Dialog appears. See Figure 5-15 on page 5-19.

```
Enter SOURCE
Coord: I 01< 1 A 01
Index: IE 00001
          Accept: N
```

Figure 5-15 Insert Clean Tape Dialog

- Step 2** Enter the source Coord, Index, and Accept.

The Insert Range Dialog appears. See Figure 5-16.

```
Insert Range:      01<
          Accept : N
```

Figure 5-16 Range Dialog

- Step 3** Enter the number of cleaning cartridges in the I/E station (Insert Range), and Accept.

The Target Dialog appears. See Figure 5-17.

```
Enter TARGET
Coord: S 01 1< A 01
Index: ST 00001
          Accept : N
```

Figure 5-17 Enter Target Dialog

- Step 4** Enter the Target Coord (the starting address for inserting cleaning cartridges), Index, and Accept.

The Current Dialog appears. See Figure 5-18.

```
Current  Use: 000<
Max      Use: 000

Accept: N
```

Figure 5-18 Current Dialog

 **Note**

Maximum used:
SDLT/DLT = 20
LTO = 20
AIT = 10

- Step 5** Enter Current (how many times the cleaning cartridge has been used), Max (how many time the cleaning cartridge can be used before it must be ejected), and Accept.

When the insert operation completes the Command Complete Dialog appears. See Figure 5-19.

```
Requested command is
now complete.

Tapes inserted: 001
```

Figure 5-19 Command Complete Dialog

Eject a Cleaning Cartridge

This procedure describes how to eject a cleaning tape. For more information, refer to *Eject Clean Tape Dialog* on page 4-58.

- Step 1** From the operator panel Main Menu, select **Commands ► Insert/Eject ► Eject Clean Tape**.

The Insert Clean Tape Dialog appears. See Figure 5-20.

```
Enter SOURCE
Coord: S 01 1< A 01
Index: ST 00001
          Accept: N
```

Figure 5-20 Insert Clean Tape Dialog

- Step 2** Enter the source Coord, Index, and Accept.

The Eject In Progress appears. See Figure 5-21.

```
Eject in progress
Source : 00001
Target : 00788
```

Figure 5-21 Eject In Progress

- Step 3** The cleaning cartridge is ejected to the first available slot in the I/E station.

The Complete Dialog appears. See Figure 5-22.

```
Requested command is
now complete.
```

Figure 5-22 Complete Dialog

AutoClean

The host should not share Scalar 10K controlled cleaning media. If a host does share the Scalar 10K firmware controlled cleaning media, the Scalar 10K firmware does not change or update cleaning media usage information.

Use this procedure to set autoclean. For more information, refer to *Drives Dialog* on page 4-96.

Step 1 From the operator panel Main Menu, select **Setup ► Cleaning**.

The Cleaning Submenu appears. See Figure 5-23.

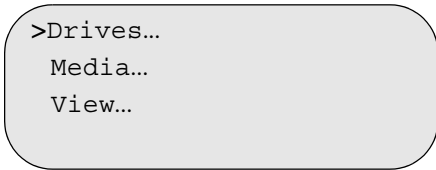

```
>Drives...
Media...
View...
```

Figure 5-23 Cleaning Submenu

Step 2 Select **Drives**.

The AutoClean dialog appears. See Figure 5-24.

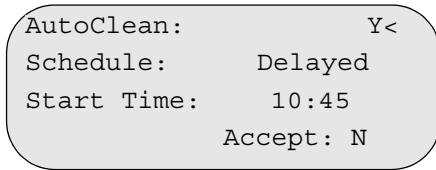

```
AutoClean:           Y<
Schedule:           Delayed
Start Time:         10:45
                    Accept: N
```

Figure 5-24 AutoClean Dialog

Step 3 Select AutoClean, set the schedule (immediate or delayed), Hours, Min (time to start the cleaning), Accept.

Immediate - every dismount causes the firmware to check for a cleaning request from the drive and cleans the drive immediately.

Delayed - sets the cleaning process time by setting the Hour and Min option values.

If the firmware receives a clean drive request, the dismount response holds until the cleaning process is complete. It is recommended that the host extend the timeout period normally associated with waiting for a dismount response.

 **Note**

The Delayed option should be initiated during routine or normal downtime because the Scalar 10K goes NOT READY for the duration of the cleaning operation.

6

Error Messages

Overview	6-3
Understanding Error Messages	6-3
Operator Intervention Messages	6-4
Service Action Codes	6-11
Understanding Service Action Codes and Modifiers	6-11
Service Action Code Table	6-15
Resolving a Stuck Accessor	6-40
Error Log Form	6-41
Frequently Asked Questions	6-42

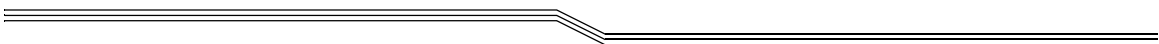



Overview

This chapter contains information on error messages, how to resolve a stuck accessor, and frequently asked questions. This chapter is organized as follows:

- *Understanding Error Messages* below
- *Operator Intervention Messages* on page 6-4
- *Service Action Codes* on page 6-11
- *Resolving a Stuck Accessor* on page 6-40
- *Error Log Form* on page 6-41
- *Frequently Asked Questions* on page 6-42

Understanding Error Messages

When a failure occurs, the Scalar 10K firmware performs error recovery and reporting. The Scalar 10K reports two types of error messages: operator panel intervention messages and Service Action Codes (SACs).

An operator intervention message is generated and displayed on the operator panel when operator intervention is required. For more information on operator intervention messages, refer to *Operator Intervention Messages* on page 6-4.

A SAC is generated and displayed on the operator panel for a failure that might require a service call. Depending on the SAC, operator intervention and/or a service call is required. For more information on SACs, refer to *Service Action Codes* on page 6-11.

Operator Intervention Messages

Table 6-1 describes the operator intervention messages. Each message may contain up to four lines of information, including variable information that is specific to the message. For SAC indications, refer to *Service Action Codes* on page 6-11.

Table 6-1 Operator Intervention Messages

Message Lines	Variables
MOTION PROHIBITED! Safety flag is reset when aisle door is opened.	None.
Alert not found. Press Enter.	None
-->ERROR!<-- Initialization Error Code: 0x%Y	%Y = 0x(8 digits) error modifier
-->PERM ERROR!<-- CALL FOR SERVICE SAC: %X %R %B %E Code:0x%Y	%X = 2-digit hex %R = 2-digit decimal %B = 2-digit decimal %E = 1-digit hex (not always present) %Y = 8-digit hex
-->PERM ERROR!<-- SYSTEM WILL REBOOT SAC: %X %R %B %E Code:0x%Y	%X = 2-digit hex %R = 2-digit decimal %B = 2-digit decimal %E = 1-digit hex (not always present) %Y = 8-digit hex
->SYSTEM REBOOTED<- NEW CODE LOADED Version %XXXA.%YYYYY	XXX = major revision YYYY = minor revision For example: 224A.00001 XXXA = 224A YYYYY = 00001

Table 6-1 Operator Intervention Messages (Continued)

Message Lines	Variables
<pre>->SYSTEM REBOOTED<- RECOVERED FROM ERROR SAC: %X %R %B %E Code:0x%Y</pre>	<pre>%X = 2-digit hex %R = 2-digit decimal %B = 2-digit decimal %E = 1-digit hex (not always present) %Y = 8-digit hex</pre>
<pre>->SYSTEM REBOOTED<- CALL FOR SERVICE SAC: %X %R %B %E Code:0x%Y</pre>	<pre>%X = 2-digit hex %R = 2-digit decimal %B = 2-digit decimal %E = 1-digit hex (not always present) %Y = 8-digit hex code</pre>
<pre>->TOO MANY ERRORS!<- CALL FOR SERVICE SAC: %X %R %B %E Code:0x%Y</pre>	<pre>%X = 2-digit hex %R = 2-digit decimal %B = 2-digit decimal %E = 1-digit hex (not always present) %Y = 8-digit hex</pre>
<pre>INTERVENTION NEEDED! Unexpected door open detected for IE Station %X</pre>	<pre>%X = 2-digit decimal</pre>
<pre>INTERVENTION NEEDED! Unexpected door open detected. Check all doors for closure.</pre>	<pre>None</pre>
<pre>INTERVENTION NEEDED! SE device detected on first differen- tial SCSI bus.</pre>	<pre>None</pre>
<pre>INTERVENTION NEEDED! SE device detected on second differen- tial SCSI bus.</pre>	<pre>None</pre>
<pre>INTERVENTION NEEDED! Check connection and/or termination on first SCSI bus.</pre>	<pre>None</pre>

Table 6-1 Operator Intervention Messages (Continued)

Message Lines	Variables
INTERVENTION NEEDED! Check connection and/or termination on second SCSI bus.	None
INTERVENTION NEEDED! Remove cartridge in gripper, place back into [%Y %Z %A %B].	%Y = rack number %Z = section number %A = column letter %B = row number
INTERVENTION NEEDED! Storage may be full, or IE magazine types may be incorrect.	None
INTERVENTION NEEDED! Cartridge extended in front of gripper. Reseat into %X [%Y %Z %A %B]	%X = index %Y = rack number %Z = section number %A = column letter %B = row number
INTERVENTION NEEDED! Unexpected door open detected for rack position %X	%X = 2-digit decimal
SERVICE MODE Cannot go online Replace Terminator	None
BAD MEDIA Cannot get type. Please label media. %X [%Y %Z %A %B]	%X = index number %Y = rack number %Z = section number %A = column letter %B = row number
INTERVENTION NEEDED! Cartridge recovered too many options! %X [%Y %Z %A %B]	%X = index number %Y = rack number %Z = section number %A = column letter %B = row number
UPSIDE DOWN MEDIA Ensure cartridge is in cell properly. %X [%Y %Z %A %B]	%X = index number %Y = rack number %Z = section number %A = column letter %B = row number

Table 6-1 Operator Intervention Messages (Continued)

Message Lines	Variables
CELL IS OBSTRUCTED Please check to see if cell is empty. %X [%Y %Z %A %B]	%X = index number %Y = rack number %Z = section number %A = column letter %B = row number
CELL IS EMPTY Please check to see if cell is full. %X [%Y %Z %A %B]	%X = index number %Y = rack number %Z = section number %A = column letter %B = row number
DRIVE COMM FAILED Please verify drive communication path. %X [%Y %Z %A %B]	%X = index number %Y = rack number %Z = bay number %A = column letter %B = row number
SCSI/LOOP ID MISSING ID set to %I for drive %X at [%Y %Z %A %B]	%I = ID number %X = index number %Y = rack number %Z = bay number %A = column letter %B = row number
TAPE STUCK IN DRIVE Drive disabled until tape is removed. DT %X %YY	%X = drive index %YY = library coordinate
TAPE PUSH FAILED Please remove tape from drive. %X [%Y %Z %A %B]	%X = index number %Y = rack number %Z = bay number %A = column letter %B = row number
CLEAN TAPE MISSING A previously defined tape is missing %X	%X = volser number
CLEAN TAPE EXPIRED Please remove the cleaning tape number %X volser %Y	%X = tape number %Y = volser number

Table 6-1 Operator Intervention Messages (Continued)

Message Lines	Variables
INTERVENTION NEEDED! Locate dropped cartridge and insert into [%Y %Z %A %B]	%Y = rack number %Z = section number %A = column letter %B = row number
DRIVE INIT FAILED Please correct drive initialization for %X [%Y %Z %A %B]	%X = index number %Y = rack number %Z = bay number %A = column letter %B = row number
DRIVE CLEAN FAILED A cleaning operation failed to clean. %X [%Y %Z %A %B]	%X = index number %Y = rack number %Z = bay number %A = column letter %B = row number
UCODE UPDATE FAILED A firmware update failed for %X at [%Y %Z %A %B]	%X = index number %Y = rack number %Z = bay number %A = column letter %B = row number
POWER SUPPLY ERROR Please check status of 24V power supply number %X	%X = power supply number
POWER SUPPLY ERROR Please check status of 48V power supply number %X	%X = power supply number
POWER SUPPLY ERROR Check AC box and AC connection to 24V PS number %X or POWER SUPPLY ERROR Check AC box and AC connection to 48V PS number %X	%X = power supply number

Table 6-1 Operator Intervention Messages (Continued)

Message Lines	Variables
<p>TOWER INIT FAILED Please correct tower initialization for tower %Y</p>	<p>%Y = rack number</p>
<p>TOWER NOT ONLINE Please correct the tower status for tower %Y</p>	<p>%Y = rack number</p>
<p>TOWER WRONG MODE Please set mode to %X for tower %Y</p>	<p>%X = mode %Y = rack number</p>
<p>INVALID LABEL Please check cart for valid label. %X [%Y %Z %A %B]</p>	<p>%X = index number %Y = rack number %Z = section number %A = column letter %B = row number</p>
<p>DUPLICATE LABEL Please check cells %X1 [%Y1 %Z1 %A1 %B1] %X2 [%Y2 %Z2 %A2 %B2]</p>	<p>%X = index number %Y = rack number %Z = section number %A = column letter %B = row number</p>
<p>TEACH FAILURE If the teach failure was with a drive: Please correct teach at drive location at %Y, %Z or If the teach failure was with a storage element: Please correct teach at storage location at %Y, %Z</p>	<p>%Y = rack number %Z = either drive number (1 to 48) for drive location within rack or section number (1 to 5) for storage location.</p>
<p>INTERVENTION NEEDED! Magazine configuration incorrect for IE station %X</p>	<p>%X = 2-digit decimal</p>

Table 6-1 Operator Intervention Messages (Continued)

Message Lines	Variables
WARNING! The inventory may not be current. [OK]	None
INTERVENTION NEEDED! Cartridge was either dropped or is in %X [%Y %Z %A %B]	%X = index number %Y = rack number %Z = section number %A = column letter %B = row number
DRIVE UNLOAD FAILED An unload or eject operation failed for %X [%Y %Z %A %B]	%X = index number %Y = rack number %Z = bay number %A = column letter %B = row number
BAD FIRMWARE MEDIA Media not detected as a firmware tape. %X [%Y %Z %A %B]	%X = index number %Y = rack number %Z = section number %A = column letter %B = row number
DEMO CLEANUP FAILED Please move media in %X1 [%Y1 %Z1 %A1 %B1] to %X2 [%Y2 %Z2 %A2 %B2]	%X = index number %Y = rack number %Z = section number %A = column letter %B = row number
DRIVE TAPE ALERT %C CALL FOR SERVICE %X [%Y %Z %A %B]	%C = tape alert number %X = index number %Y = rack number %Z = bay number %A = column letter %B = row number

Service Action Codes

This section contains information on SACs and is organized as follows:

- *Understanding Service Action Codes and Modifiers* on page 6-11
- *Service Action Code Table* on page 6-15

Understanding Service Action Codes and Modifiers

SACs are used to help define the cause of the problem. If a failure occurs that requires operator intervention and/or a service call, a SAC is generated and displayed on the operator panel. A SAC is the result of the Scalar 10K firmware analyzing all pertinent system information available at the time of a failure, such as sense data, the operation in progress, error and threshold data, and any data returned from diagnostic routines invoked by the firmware to isolate the failure.

When a SAC is displayed on the operator panel, make sure to write down all of the SAC information displayed, including the 10-character code (for example, 0x02110000) that follows the SAC. This information can be used to help diagnose the problem.

Each SAC consists of three bytes (**nn xx yy**) or four bytes (**nn xx yy z**) as described below:

- **nn**: SAC.
- **xx yy z**: SAC modifier. For most SACs, the modifier has a value of **00 00** but for some SACs, this value is used to further identify the physical location of the failing FRU or component as described for **xx yy**. The additional **z** byte is the single digit character error code displayed by tape drives. The **z** byte provides tape drive information that may or may not be useful in determining the problem.
 - **xx** is the rack where the failing FRU or component is located. **xx** has value ranging from **01** to **16**:
 - **00**: do not care condition
 - **01-16**: rack number from **1** to **16**
 - **yy** has a number of values depending on the SAC:
 - **00**: do not care condition

-
-
- **01-48:** For drive failures, this value indicates drive location, with **01** being the bottom right drive location (viewing from the back of the module) and **48** being the top left drive location (for UDS half-height). Drives are counted from right to left and bottom to top. For information on drive location numbering for all drive types, see Figure 6-1 on page 6-13 and Figure 6-2 on page 6-14.

— or —

- **01-04:** For I/E Station failures, the value indicates the Insert/Eject station number from **1** to **4**.

— or —

- **01-04:** For UDS Power Supply failures, this value indicates drive bay number from **1** to **4** with **1** being the bottom drive bay and **4** being the top drive bay. For more information on drive bay numbering for each drive type, see Figure 6-1 on page 6-13 and Figure 6-2 on page 6-14.

— or —

- **01-05:** For Storage Assembly failures, this value indicates section numbers within a rack from **1** to **5**, with **1** being the top section and **5** being the bottom section.
- **z** is the single digit character error code displayed by certain tape drives on a SAC 96.

UDS Control Module With Two Drive Bays First UDS Drive Module With Four Drive Bays

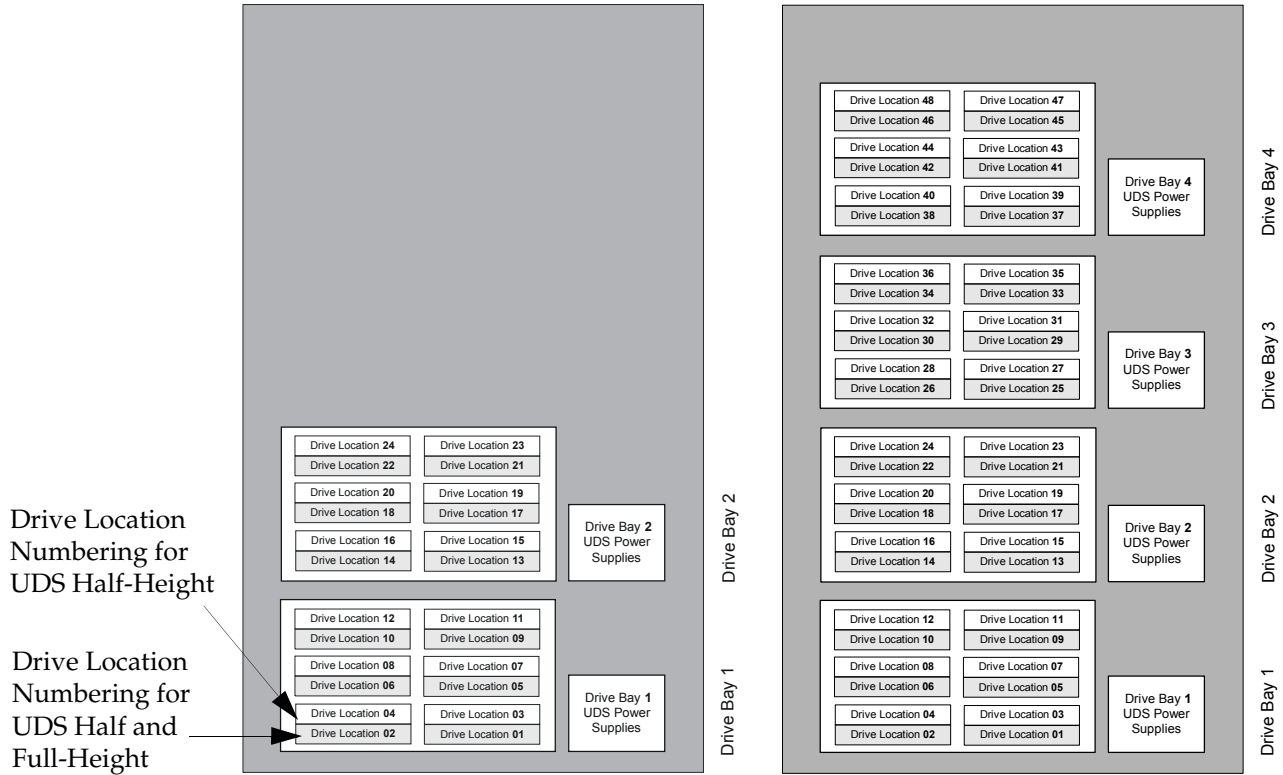

Figure 6-1 UDS Full and Half-Height Drive Bay/Drive Location Numbering

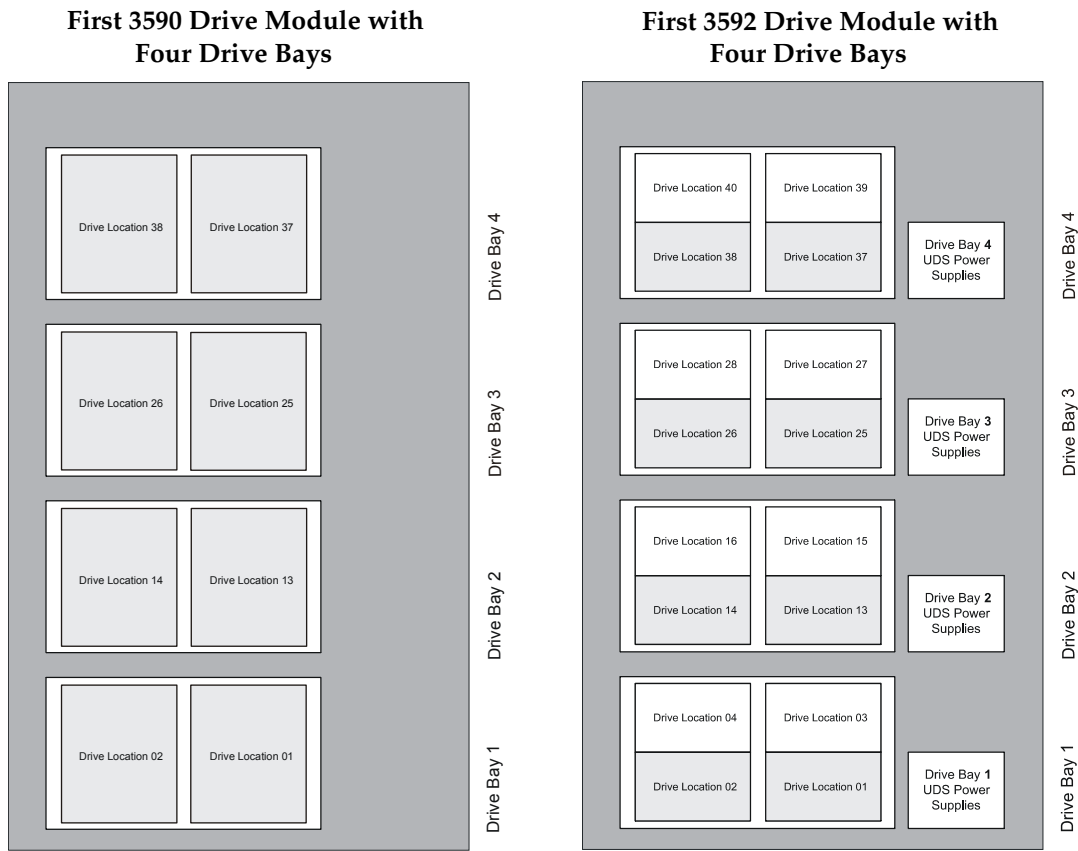

Figure 6-2 3590 and 3592/TS11210 Drive Bay/Drive Location Numbering

Service Action Code Table

Table 6-2 lists all SACs and their corresponding SAC-resolution actions.

For each SAC, always perform the actions in the order presented, starting with Action 1 and continuing down the list until the problem is resolved or you are instructed to call the GCH.

Table 6-2 Service Action Codes

Reported SAC	Perform these actions
01 00 00	Type 1 Software errors including Microcode and Operating System errors.
	Action 1 Power Off and On the Scalar 10K library to recover from the error. Refer to <i>Shutting Down the Scalar 10K</i> on page 3-8 and <i>Starting the Scalar 10K</i> on page 3-7. Wait at least one minute between powering Off and On the library.
	Action 2 If the problem is not corrected or persists, contact GCH. For GCH contact information, refer to <i>Getting More Information or Help</i> on page 1-8.
02 00 00	Type 2 Software errors including Microcode logic errors during Get/Put operations.
	Action 1 Power Off and On the Scalar 10K library to recover from the error. Refer to <i>Shutting Down the Scalar 10K</i> on page 3-8 and <i>Starting the Scalar 10K</i> on page 3-7. Wait at least one minute between powering Off and On the library.
	Action 2 If the problem is not corrected or persists, contact GCH. For GCH contact information, refer to <i>Getting More Information or Help</i> on page 1-8.
03 00 00	Type 3 Software errors resulting from unexpected hardware conditions. These errors are primarily generated when it is not safe to move the accessor).
	Action 1 Power Off and On the Scalar 10K library to recover from the error. Refer to <i>Shutting Down the Scalar 10K</i> on page 3-8 and <i>Starting the Scalar 10K</i> on page 3-7. Wait at least one minute between powering Off and On the library.
	Action 2 If the problem is not corrected or persists, contact GCH. For GCH contact information, refer to <i>Getting More Information or Help</i> on page 1-8.

Table 6-2 Service Action Codes (Continued)

Reported SAC	Perform these actions
04 00 00	Type 4 Software errors (inter Processor) including Microcode and Operating System errors.
	<p>Action 1 Power Off and On the Scalar 10K library to recover from the error. Refer to <i>Shutting Down the Scalar 10K</i> on page 3-8 and <i>Starting the Scalar 10K</i> on page 3-7. Wait at least one minute between powering Off and On the library.</p>
	<p>Action 2 If the problem is not corrected or persists, contact GCH. For GCH contact information, refer to <i>Getting More Information or Help</i> on page 1-8.</p>
05 00 00	A permanent Operating System error occurred.
	<p>Action 1 Power Off and On the Scalar 10K library to recover from the error. Refer to <i>Shutting Down the Scalar 10K</i> on page 3-8 and <i>Starting the Scalar 10K</i> on page 3-7. Wait at least one minute between powering Off and On the library.</p>
	<p>Action 2 If the problem is not corrected or persists, contact GCH. For GCH contact information, refer to <i>Getting More Information or Help</i> on page 1-8.</p>
10 00 00	Barcode scanner communications failed.
	<p>Action 1 Power Off and On the Scalar 10K library to recover from the error. Refer to <i>Shutting Down the Scalar 10K</i> on page 3-8 and <i>Starting the Scalar 10K</i> on page 3-7. Wait at least one minute between powering Off and On the library.</p>
	<p>Action 2 If the problem is not corrected or persists, contact GCH. For GCH contact information, refer to <i>Getting More Information or Help</i> on page 1-8.</p>
11 00 00	Barcode scanner communication is OK, data received from the barcode scanner is bad.
	<p>Action 1 Contact GCH. For GCH contact information, refer to <i>Getting More Information or Help</i> on page 1-8.</p>
12 00 00	Barcode scanner communication is OK, barcode scanner reports that data is bad.
	<p>Action 1 Contact GCH. For GCH contact information, refer to <i>Getting More Information or Help</i> on page 1-8.</p>

Table 6-2 Service Action Codes (Continued)

Reported SAC	Perform these actions
13 00 00	<p data-bbox="461 386 1008 415">Cannot read barcode label or the label is bad.</p> <p data-bbox="461 443 565 470">Action 1</p> <p data-bbox="461 474 930 501">Check the barcode label to verify that it:</p> <ul data-bbox="461 506 1365 600" style="list-style-type: none"> <li data-bbox="461 506 1365 564">• meets the specifications listed <i>Barcode Labels</i> on page 5-12 and <i>Barcode Label Restrictions</i> on page 5-14. <li data-bbox="461 569 1240 600">• is applied correctly as described in <i>Applying Labels</i> on page 5-13. <p data-bbox="461 632 1011 659">In addition, verify that the barcode label is not:</p> <ul data-bbox="461 663 1313 724" style="list-style-type: none"> <li data-bbox="461 663 704 695">• damaged or dirty. <li data-bbox="461 699 1313 724">• too short (less than 5 characters) or too long (more than 16 characters). <p data-bbox="461 758 1333 819">The cell in question is displayed with the SAC. Run Start Option from the operator panel to retrieve this information (Main Menu ► Service ► Start).</p> <p data-bbox="461 846 565 873">Action 2</p> <p data-bbox="461 877 976 905">Make sure that scan beam is not obstructed.</p> <p data-bbox="461 930 565 957">Action 3</p> <p data-bbox="461 961 1321 1022">If the problem is not corrected or persists, contact GCH. For GCH contact information, refer to <i>Getting More Information or Help</i> on page 1-8.</p>
14 00 00	<p data-bbox="461 1043 1227 1073">Cannot read the Serial Number label during a Teach operation.</p> <p data-bbox="461 1100 565 1127">Action 1</p> <p data-bbox="461 1131 1349 1192">Check the Serial Number label to ensure that it is installed properly and not damaged or dirty.</p> <p data-bbox="461 1197 1357 1287">The Serial Number label is located in the middle of the top storage assembly in the Control Module. The Serial Number label contains a barcode and readable serial number such as 2021 00031.</p> <p data-bbox="461 1314 565 1341">Action 2</p> <p data-bbox="461 1346 1365 1407">Contact GCH. For GCH contact information, refer to <i>Getting More Information or Help</i> on page 1-8.</p>
15 00 00	<p data-bbox="461 1428 1354 1488">The barcode scanner is not capable of fully supporting all different labels in the Scalar 10K library.</p> <p data-bbox="461 1516 565 1543">Action 1</p> <p data-bbox="461 1547 1365 1608">Contact GCH. For GCH contact information, refer to <i>Getting More Information or Help</i> on page 1-8.</p>
20 00 00	<p data-bbox="461 1631 842 1661">Serial port Connection failures.</p> <p data-bbox="461 1688 565 1715">Action 1</p> <p data-bbox="461 1719 1365 1780">Contact GCH. For GCH contact information, refer to <i>Getting More Information or Help</i> on page 1-8.</p>

Table 6-2 Service Action Codes (Continued)

Reported SAC	Perform these actions
21 00 00	NVRAM failures.
	<p>Action 1 Power Off and On the Scalar 10K library to recover from the error. Refer to <i>Shutting Down the Scalar 10K</i> on page 3-8 and <i>Starting the Scalar 10K</i> on page 3-7. Wait at least one minute between powering Off and On the library.</p> <p>Action 2 If the problem is not corrected or persists, contact GCH. For GCH contact information, refer to <i>Getting More Information or Help</i> on page 1-8.</p>
22 00 00	Fail to communicate with the operator panel.
	<p>Action 1 Contact GCH. For GCH contact information, refer to <i>Getting More Information or Help</i> on page 1-8.</p>
23 00 00	An unexpected interrupt is received.
	<p>Action 1 Contact GCH. For GCH contact information, refer to <i>Getting More Information or Help</i> on page 1-8.</p>
30 00 00	A fatal error is detected in SCSI port 1.
	<p>Action 1 Verify that the SCSI bus connected to Library Port 1 is properly terminated and powered.</p>
	<p>Action 2 Verify that the SCSI ID is unique for the SCSI cable.</p>
	<p>Action 3 Verify that the Library SCSI Port 1 is properly configured by using the operator panel (Main Menu ▶ Setup ▶ Library ▶ SCSI ▶ Ports).</p>
<p>Action 4 If the problem is not corrected or persists, contact GCH. For GCH contact information, refer to <i>Getting More Information or Help</i> on page 1-8.</p>	

Table 6-2 Service Action Codes (Continued)

Reported SAC	Perform these actions
31 00 00	A fatal error is detected in SCSI port 2.
	Action 1 Verify that the SCSI bus connected to Library Port 2 is properly terminated and powered.
	Action 2 Verify that the SCSI ID is unique for the SCSI cable.
	Action 3 Verify that the Library SCSI Port 2 is properly configured by using the operator panel (Main Menu ▶ Setup ▶ Library ▶ SCSI ▶ Ports).
	Action 4 If the problem is not corrected or persists, contact GCH. For GCH contact information, refer to <i>Getting More Information or Help</i> on page 1-8.
32 00 00	Wrong SCSI bus connection is detected. A Single Ended SCSI bus is connected to the Library Port 1 Differential Adapter.
	Action 1 Verify that the Host SCSI bus is the same type as the Library SCSI Adapter card in Port 1.
	Action 2 If the problem is not corrected or persists, contact GCH. For GCH contact information, refer to <i>Getting More Information or Help</i> on page 1-8.
33 00 00	Wrong SCSI bus connection is detected. A Single Ended SCSI bus is connected to the Library Port 2 Differential Adapter.
	Action 1 Verify that the Host SCSI bus is the same type as the Library SCSI Adapter card in Port 2.
	Action 2 If the problem is not corrected or persists, contact GCH. For GCH contact information, refer to <i>Getting More Information or Help</i> on page 1-8.
34 00 00	A general SCSI failure is detected.
	Action 1 Verify that the SCSI host is working properly.
	Action 2 If the problem is not corrected or persists, contact GCH. For GCH contact information, refer to <i>Getting More Information or Help</i> on page 1-8.

Table 6-2 Service Action Codes (Continued)

Reported SAC	Perform these actions
35 00 00	A fatal SCSI error is detected but the port is unknown.
	Action 1 Verify that the SCSI busses connected to both Library Ports (if applicable) are properly terminated and powered.
	Action 2 Verify that the SCSI ID is unique for the SCSI cable.
	Action 3 Verify that both Library SCSI Ports are properly configured (if applicable) by using the operator panel (Main Menu ▶ Setup ▶ Library ▶ SCSI ▶ Ports).
	Action 4 If the problem is not corrected or persists, contact GCH. For GCH contact information, refer to <i>Getting More Information or Help</i> on page 1-8.
39 00 00	An external network error was detected by the Remote Management Unit (RMU).
	Action 1 Ensure the network cable is properly connected to the RMU.
	Action 2 Verify that the network the RMU is connected to is working properly.
	Action 3 If the problem is not corrected or persists, contact GCH. For GCH contact information, refer to <i>Getting More Information or Help</i> on page 1-8.
40 00 00	The Library Aisle power cannot be enabled.
	Action 1 Verify that the aisle doors are closed.
	Action 2 Check the door fuses or reset the circuit breaker, as applicable.
	Action 3 If the problem is not corrected or persists, contact GCH. For GCH contact information, refer to <i>Getting More Information or Help</i> on page 1-8.
41 00 00	The Library Aisle power cannot be disabled, failures are detected in the Digital In/Digital Out (DI/DO) circuitries.
	Action 1 Contact GCH. For GCH contact information, refer to <i>Getting More Information or Help</i> on page 1-8.

Table 6-2 Service Action Codes (Continued)

Reported SAC	Perform these actions
42 00 00	A wrong library configuration is detected, the data reporting the number of racks installed is different than expected.
	Action 1 Run Teach New from the operator panel (Main Menu ► Service ► Teach ► Teach New).
	Action 2 If the problem is not corrected or persists, contact GCH. For GCH contact information, refer to <i>Getting More Information or Help</i> on page 1-8.
43 00 00	An unknown library configuration is detected, the barcode scanner is unable to read the fiducial label located on a storage assembly during a Teach operation.
	Action 1 Contact GCH. For GCH contact information, refer to <i>Getting More Information or Help</i> on page 1-8.
44 00 00	An unknown fiducial label is detected during a Teach operation. This problem can be caused if a magazine containing cartridges not supported in the Library is inserted in the I/E Station.
	Action 1 Check for a dirty, damaged, missing, or wrong fiducial label where the gripper is positioned. The fiducial label can be on a storage assembly, drive, or I/E magazine.
	Action 2 Contact GCH. For GCH contact information, refer to <i>Getting More Information or Help</i> on page 1-8.
46 xx yy	During a Get or Put operation, the calculated X position exceeded the allowable limits.
	Action 1 Note the location of the storage assembly or the magazine as indicated in the SAC modifiers xx and yy: <ul style="list-style-type: none"> • xx: rack number (1 to 16) • yy: section number within a rack or I/E Station (1 to 5) For more information on SAC modifiers, refer to <i>Service Action Codes</i> on page 6-11.
	Action 2 Contact GCH. For GCH contact information, refer to <i>Getting More Information or Help</i> on page 1-8.

Table 6-2 Service Action Codes (Continued)

Reported SAC	Perform these actions
47 xx yy	During a Get or Put operation, the calculated Y position exceeded the allowable limits.
	<p>Action 1 Note the location of the storage assembly or magazine as indicated in the SAC modifiers xx and yy:</p> <ul style="list-style-type: none"> • xx: rack number (1 to 16) • yy: section number within a rack or I/E Station (1 to 5) <p>For more information on SAC modifiers, refer to <i>Service Action Codes</i> on page 6-11.</p>
	<p>Action 2 Contact GCH. For GCH contact information, refer to <i>Getting More Information or Help</i> on page 1-8.</p>
48 00 00	Aisle Fuse has opened.
	<p>Action 1 Contact GCH. For GCH contact information, refer to <i>Getting More Information or Help</i> on page 1-8.</p>
49 00 00	Top and bottom X-axis motors are different types
	<p>Action 1 The top X-axis motor and bottom X-axis motor are required to be the same type. The library firmware verifies that both motors are the same type. If they are not the same type, a SAC 49 is posted and the library will not go ready.</p>
	<p>Action 2 Contact GCH. For GCH contact information, refer to <i>Getting More Information or Help</i> on page 1-8.</p>
50 00 00	A cartridge is not properly seated in the storage cell.
	<p>Action 1 Do the following:</p> <ol style="list-style-type: none"> 1. Check the location of the gripper. 2. Make the library not ready. 3. Open the service door. 4. Verify the location of the cartridge and check it for damage. <ul style="list-style-type: none"> - If the cartridge is not damaged, put the cartridge in the storage cell and check for correct seating. - If the cartridge is damaged, remove the cartridge from the system. 5. Inspect the storage location or drive for visible damage. 6. Contact GCH. For GCH contact information, refer to <i>Getting More Information or Help</i> on page 1-8.

Table 6-2 Service Action Codes (Continued)

Reported SAC	Perform these actions
60 xx yy	Cannot complete the Lock/Unlock Insert/Eject station commands.
	<p>Action 1 Use the modifier xx yy to locate the Insert/Eject station:</p> <ul style="list-style-type: none"> • xx = rack number (1 to 16) • yy = Insert/Eject station number (1 to 4) <p>For more information on SAC modifiers, refer to <i>Service Action Codes</i> on page 6-11.</p>
	<p>Action 2 Make sure that the door (identified by xx yy) is properly closed. For the location of Insert/Eject stations, see Figure 2-1 on page 2-3.</p>
61 xx yy	The Insert/Eject Station Closed Sensor error threshold is exceeded.
	<p>Action 1 Use the modifier xx yy to locate the Insert/Eject station:</p> <ul style="list-style-type: none"> • xx = rack number (1 to 16) • yy = Insert/Eject station number (1 to 4) <p>For more information on SAC modifiers, refer to <i>Service Action Codes</i> on page 6-11.</p>
62 xx yy	A down level LIE card was detected by the library firmware when a newer version is required for this library configuration to operate.
	<p>Action 1 Use the modifier xx yy to locate the Insert/Eject station:</p> <ul style="list-style-type: none"> • xx = rack number (1 to 16) • yy = Insert/Eject station number (1 to 4) <p>For more information on SAC modifiers, refer to <i>Service Action Codes</i> on page 6-11.</p>
	<p>Action 2 Contact GCH. For GCH contact information, refer to <i>Getting More Information or Help</i> on page 1-8.</p>

Table 6-2 Service Action Codes (Continued)

Reported SAC	Perform these actions
70 00 00	<p>Failures detected in the Gripper Assembly Finger Open/Close operations.</p> <p>Action 1 Contact GCH. For GCH contact information, refer to <i>Getting More Information or Help</i> on page 1-8.</p>
71 00 00	<p>Failures detected in the Gripper Assembly Pivot operation.</p> <p>Action 1 Contact GCH. For GCH contact information, refer to <i>Getting More Information or Help</i> on page 1-8.</p>
72 00 00	<p>A Get command was issued but the sensor indicated that a cartridge is already present in the Gripper Assembly.</p> <p>Action 1 Look into the Gripper Assembly and see if a cartridge is present. Then, do one of the following:</p> <ul style="list-style-type: none"> • If a cartridge is found, perform the actions in SAC 02 00 00. • If no cartridge is found in the Gripper Assembly, contact GCH. For GCH contact information, refer to <i>Getting More Information or Help</i> on page 1-8.
73 00 00	<p>Failures detected in the Gripper Assembly Touch Tip operation.</p> <p>Action 1 Contact GCH. For GCH contact information, refer to <i>Getting More Information or Help</i> on page 1-8.</p>

Table 6-2 Service Action Codes (Continued)

Reported SAC	Perform these actions
74 00 00	<p data-bbox="461 390 1367 453">A Get command was issued but the sensor indicated that the source location is empty.</p> <p data-bbox="461 474 1367 642">Action 1 This error can be caused by a cartridge not fully inserted in the storage cell above the failing cell. Check to see if this condition exists, if it does, push the cartridge into its cell and re-inventory the entire column containing the cell (Main Menu ► Commands ► Inventory).</p> <p data-bbox="461 653 1367 999">Action 2 If a cartridge is present, do the following: <ol data-bbox="461 716 1367 936" style="list-style-type: none"> 1. If the source is a drive element, make sure that the drive sled is completely seated into the drive slot. 2. If the source is an IE element, make sure that the magazine is completely seated and the IE door is completely closed. 3. If the source is a storage element or if the above actions do not help, contact GCH. For GCH contact information, refer to <i>Getting More Information or Help</i> on page 1-8. If a cartridge is not present, the source cell is automatically inventoried by the library after the failed Get.</p>
75 00 00	<p data-bbox="461 1026 1367 1058">A failure is detected in the Gripper Assembly.</p> <p data-bbox="461 1079 1367 1173">Action 1 Contact GCH. For GCH contact information, refer to <i>Getting More Information or Help</i> on page 1-8.</p>
76 00 00	<p data-bbox="461 1194 1367 1226">A Teach failure was detected.</p> <p data-bbox="461 1247 1367 1341">Action 1 Contact GCH. For GCH contact information, refer to <i>Getting More Information or Help</i> on page 1-8.</p>
77 00 00	<p data-bbox="461 1362 1367 1425">Failures detected in the Gripper Assembly during a Reach/Retract operation.</p> <p data-bbox="461 1446 1367 1551">Action 1 Verify that there is nothing obstructing the Gripper Assembly from reaching its target.</p> <p data-bbox="461 1562 1367 1656">Action 2 If the problem is not corrected or persists, contact GCH. For GCH contact information, refer to <i>Getting More Information or Help</i> on page 1-8.</p>

Table 6-2 Service Action Codes (Continued)

Reported SAC	Perform these actions
7A 00 00	Failures detected in the Gripper Assembly Retract operations.
	<p>Action 1 Contact GCH. For GCH contact information, refer to <i>Getting More Information or Help</i> on page 1-8.</p>
7B 00 00	Failure detected in a Teach Master operation. This failure occurs most likely when a Teach operation is executed as part of the Installation process.
	<p>Action 1 Contact GCH. For GCH contact information, refer to <i>Getting More Information or Help</i> on page 1-8.</p>
7C 00 00	Failures detected in the Gripper Assembly Reach operation.
	<p>Action 1 Check for an object blocking operation in the cell. An obstruction can be any of the following:</p> <ul style="list-style-type: none"> • an unlabeled cartridge • a cartridge in the cell during a Put operation • the DLT drive door is stuck during a Put operation <p>Remove the obstruction, then close the aisle door and retry the failing operation.</p>
	<p>Action 2 If the problem is not corrected or persists, contact GCH. For GCH contact information, refer to <i>Getting More Information or Help</i> on page 1-8.</p>
7E 00 00	Failure detected while pushing a cartridge into a tape drive feed slot.
	<p>Action 1 Check the cartridge for any physical damage, and verify that the cartridge label is correct.</p>
	<p>Action 2 Check the front of the drive sled to make sure no physical obstructions are preventing the tape from being inserted.</p>
	<p>Action 3 If the problem is not corrected or persists, contact GCH. For GCH contact information, refer to <i>Getting More Information or Help</i> on page 1-8.</p>

Table 6-2 Service Action Codes (Continued)

Reported SAC	Perform these actions
80 00 00	<p>Failures detected in the X-axis servo system.</p> <p>Action 1 Contact GCH. For GCH contact information, refer to <i>Getting More Information or Help</i> on page 1-8.</p>
81 00 00	<p>Failures detected in the Y-axis servo system.</p> <p>Action 1 Contact GCH. For GCH contact information, refer to <i>Getting More Information or Help</i> on page 1-8.</p>
82 00 00	<p>An unexpected Motor Control condition was received.</p> <p>Action 1 Contact GCH. For GCH contact information, refer to <i>Getting More Information or Help</i> on page 1-8.</p>
83 00 00	<p>The Locate Fiducial Command failed with no target found. This failure happens most likely during an initial installation of the Library Subsystem.</p> <p>Action 1 Run Teach New from the operator panel (Main Menu ► Service ► Teach ► Teach New).</p> <p>Action 2 If the problem is not corrected or persists, contact GCH. For GCH contact information, refer to <i>Getting More Information or Help</i> on page 1-8.</p>
84 00 00	<p>Y-axis failed to reach target.</p> <p>Action 1 Contact GCH. For GCH contact information, refer to <i>Getting More Information or Help</i> on page 1-8.</p>
85 00 00	<p>X-axis failed to reach target.</p> <p>Action 1 Contact GCH. For GCH contact information, refer to <i>Getting More Information or Help</i> on page 1-8.</p>

Table 6-2 Service Action Codes (Continued)

Reported SAC	Perform these actions
86 00 00	The first full speed move command issued when the accessor is at home position failed.
	<p>Action 1 Press the Ready button on the operator panel and observe the accessor to see which axis (X or Y) fails to move.</p>
	<p>Action 2 Contact GCH. For GCH contact information, refer to <i>Getting More Information or Help</i> on page 1-8.</p>
87 00 00	The accessor cannot move away from X-axis home position.
	<p>Action 1 Contact GCH. For GCH contact information, refer to <i>Getting More Information or Help</i> on page 1-8.</p>
88 00 00	The accessor cannot move away from Y-axis home position.
	<p>Action 1 Contact GCH. For GCH contact information, refer to <i>Getting More Information or Help</i> on page 1-8.</p>
90 00 00	A down level LSC card was detected by the library firmware when a newer version one is required for this library configuration to operate.
	<p>Action 1 Contact GCH. For GCH contact information, refer to <i>Getting More Information or Help</i> on page 1-8.</p>
91 00 00	A down level LMC card was detected by the library firmware when a newer version one is required for this library configuration to operate.
	<p>Action 1 Contact GCH. For GCH contact information, refer to <i>Getting More Information or Help</i> on page 1-8.</p>

Table 6-2 Service Action Codes (Continued)

Reported SAC	Perform these actions
92 xx yy	<p>A down level LBI card was detected by the library firmware when a newer version is required for this library configuration to operate.</p>
	<p>Action 1 Use the modifier xx yy to locate the card:</p> <ul style="list-style-type: none"> • xx = rack number (1 to 16) • yy = 00 do not care condition <p>See <i>Service Action Codes</i> on page 6-11 for more information.</p>
	<p>Action 2 Contact GCH. For GCH contact information, refer to <i>Getting More Information or Help</i> on page 1-8.</p>
93 xx yy	<p>A failure was detected in the drive communication hardware within the Library. The Library cannot communicate with one or more drives.</p>
	<p>Action 1 Use the modifier xx yy to locate the failing tape drive:</p> <ul style="list-style-type: none"> • xx = rack number (1 to 16) • yy = drive location (1 to 48) <p>Where 1 is the bottom right drive location (viewing from the back of the module) and 48 being the top left drive location. Drives are counted from right to left and bottom to top. Refer to <i>Service Action Codes</i> on page 6-11 for more information on SAC modifiers.</p>
	<p>Action 2 If the accompanying message indicated that the Library cannot communicate with one specific tape drive, do the following to power cycle the drive:</p> <ol style="list-style-type: none"> 1. Vary Off the drive (Main Menu ► Utils ► Drives ► Status Change ► Vary Off). 2. Reseat the drive. Wait for the following green LED blink pattern: Blink, blink, blink, pause. 3. Vary on the drive (Main Menu ► Utils ► Drives ► Status Change ► Vary On). 4. Retry the operation that failed. 5. If the problem is not corrected or persists, contact GCH. For GCH contact information, refer to <i>Getting More Information or Help</i> on page 1-8. <p>If the Library cannot communicate with any drive in this module, then contact GCH.</p>

Table 6-2 Service Action Codes (Continued)

Reported SAC	Perform these actions
94 xx yy	<p>Communication was established between the Library and the tape drive but the Library cannot determine the status of a particular Tape drive.</p>
	<p>Action 1 Use the modifier xx yy to locate the failing tape drive:</p> <ul style="list-style-type: none"> • xx = rack number (1 to 16) • yy = drive location (1 to 48) <p>Where 1 is the bottom right drive location (viewing from the back of the module) and 48 being the top left drive location. Drives are counted from right to left and bottom to top. Refer to <i>Service Action Codes</i> on page 6-11 for more information on SAC modifiers.</p>
	<p>Action 2 Do the following to power cycle the drive:</p> <ol style="list-style-type: none"> 1. Vary Off the drive (Main Menu ▶ Utils ▶ Drives ▶ Status Change ▶ Vary Off). 2. Reseat the drive. Wait for the following green LED blink pattern: Blink, blink, blink, pause. 3. Vary on the drive (Main Menu ▶ Utils ▶ Drives ▶ Status Change ▶ Vary On). 4. Retry the operation that failed.
	<p>Action 3 If the problem is not corrected or persists, contact GCH. For GCH contact information, refer to <i>Getting More Information or Help</i> on page 1-8.</p>

Table 6-2 Service Action Codes (Continued)

Reported SAC	Perform these actions
95 xx yy	An error was detected and reported by the drive sled.
	<p>Action 1 Use the modifier xx yy to locate the failing tape drive:</p> <ul style="list-style-type: none"> • xx = rack number (1 to 16) • yy = drive location (1 to 48) <p>Where 1 is the bottom right drive location (viewing from the back of the module) and 48 being the top left drive location. Drives are counted from right to left and bottom to top. Refer to <i>Service Action Codes</i> on page 6-11 for more information on SAC modifiers.</p>
	<p>Action 2 Do the following to power cycle the drive:</p> <ol style="list-style-type: none"> 1. Vary Off the drive (Main Menu ► Utils ► Drives ► Status Change ► Vary Off). Note that the SAC modifier xx yy coordinate system is not used to Vary Off a drive. A different coordinate system is used to Vary Off a drive. For more information, refer to <i>Vary Off Dialog</i> on page 4-109. 2. Open the CM or DM service door. 3. Reseat the drive sled by pulling it out an inch and inserting back into the 2-pack. Do not remove the drive sled all the way. Wait for the following green LED blink pattern: Blink, blink, blink, pause. 4. Vary on the drive (Main Menu ► Utils ► Drives ► Status Change ► Vary On). Note that the SAC modifier xx yy coordinate system is not used to Vary On a drive. A different coordinate system is used to Vary On a drive. For more information, refer to <i>Vary On Dialog</i> on page 4-110. 5. Close the CM or DM service door. 6. Retry the original operation that failed.
	<p>Action 3 If the problem is not corrected or persists, contact GCH. For GCH contact information, refer to <i>Getting More Information or Help</i> on page 1-8.</p>

Table 6-2 Service Action Codes (Continued)

Reported SAC	Perform these actions
<p>96 xx yy</p> <p>or</p> <p>96 xx yy z</p>	<p>Library detected a tape drive hardware failure.</p> <hr/> <p>Action 1 Use the modifier xx yy z to locate the failing tape drive:</p> <ul style="list-style-type: none"> • xx = rack number (1 to 16) • yy = drive location (1 to 48) • z = character error displayed on some tape drive types <p>For the yy modifiers, 1 is the bottom right drive location (viewing from the back of the module) and 48 being the top left drive location. Drives are counted from right to left and bottom to top. Refer to <i>Service Action Codes</i> on page 6-11 for more information on SAC modifiers.</p> <hr/> <p>Action 2 For UDS Drives: 1. Contact GCH and provide them with the SAC and modifier information. For GCH contact information, refer to <i>Getting More Information or Help</i> on page 1-8.</p> <p>For 3590 Drives: 1. Read the error code on the drive panel and record it for later use. 2. Vary Off the tape drive. (Main Menu ▶ Utils ▶ Drives ▶ Status Change ▶ Vary Off). 3. Power off the tape drive using the drive power switch. 4. Check the cabling. 5. Power on the tape drive using the drive power switch. 6. Vary On the tape drive. (Main Menu ▶ Utils ▶ Drives ▶ Status Change ▶ Vary On). 7. If the problem is not corrected or persists, contact GCH. For GCH contact information, refer to <i>Getting More Information or Help</i> on page 1-8.</p>
<p>97 xx yy</p>	<p>The Library detected that the firmware level of one of its Controllers (LSC, LGR, TCL, LBI, LDC) is different than the firmware level of the rest of the library. Note: If the Library is running firmware version 210A or earlier and has patch code installed, a SAC 97 is anticipated.</p> <hr/> <p>Action 1 If firmware levels are incorrect, contact GCH. For GCH contact information, refer to <i>Getting More Information or Help</i> on page 1-8.</p>

Table 6-2 Service Action Codes (Continued)

Reported SAC	Perform these actions
99 xx yy	<p>Incorrect tape drive product ID. Note: This error has no impact on library operations.</p>
	<p>Action 1 This problem does not require any action to continue library operations. However, contact GCH to correct this improper product ID problem. For GCH contact information, refer to <i>Getting More Information or Help</i> on page 1-8.</p>
9B xx yy	<p>A failure occurred in response to a Load command.</p>
	<p>Action 1 Use the modifier xx yy z to locate the failing tape drive:</p> <ul style="list-style-type: none"> • xx = rack number (1 to 16) • yy = drive location (1 to 48) <p>For the yy modifiers, 1 is the bottom right drive location (viewing from the back of the module) and 48 being the top left drive location. Drives are counted from right to left and bottom to top. Refer to <i>Service Action Codes</i> on page 6-11 for more information on SAC modifiers.</p>
	<p>Action 2</p> <ul style="list-style-type: none"> • If possible, move the cartridge to another drive of the same type. If this resolves the problem, then the drive may be bad. Contact GCH. For GCH contact information, refer to <i>Getting More Information or Help</i> on page 1-8. • If moving the cartridge to another drive does not resolve the error, insert a different cartridge of the same type into the original drive. If this resolves the problem, the cartridge may be bad.
9C xx yy	<p>A failure occurred in a 3592-J1A tape drive.</p>
	<p>Action 1 Use the modifier xx yy to locate the failing tape drive:</p> <ul style="list-style-type: none"> • xx = rack number (1 to 16) • yy = drive location (1 to 40) <p>For the yy modifiers, 1 is the bottom right drive location (viewing from the back of the module) and 48 being the top left drive location. Drives are counted from right to left and bottom to top. Refer to <i>Service Action Codes</i> on page 6-11 for more information on SAC modifiers.</p>
	<p>Action 2 Leave the tape drive in the failing state, record all SAC modifier information, and contact GCH. For GCH contact information, refer to <i>Getting More Information or Help</i> on page 1-8.</p>

Table 6-2 Service Action Codes (Continued)

Reported SAC	Perform these actions
A0 00 00	A failure was detected when the LSC attempts to communicate with the Remote Management Unit (RMU).
	Action 1 Verify that the RMU is connected.
	Action 2 Verify that the Serial Port is set to RMU (Main Menu ► Setup ► Library ► Trace ► Serial Port).
	Action 3 Reboot the RMU. Refer to <i>Rebooting the RMU</i> on page 3-21.
	Action 4 If the problem is not corrected or persists, contact GCH. For GCH contact information, refer to <i>Getting More Information or Help</i> on page 1-8.
A1 00 00	Time out expires on the LSC card waiting for response from the RMU.
	Action 1 Reboot the RMU. Refer to <i>Rebooting the RMU</i> on page 3-21.
	Action 2 If the problem is not corrected or persists, contact GCH. For GCH contact information, refer to <i>Getting More Information or Help</i> on page 1-8.
A2 xx yy	A failure was detected when the LSC card attempted to communicate with the LGR card or a controller in a rack (LBI or TCL).
	Action 1 Do one of the following: <ul style="list-style-type: none"> • If xx yy = 00 00, communication failure occurred with the LGR card. Power down the Library to re-initialize the LGR card, then check the LED on the LGR card to see if it is flashing. Refer to <i>Shutting Down the Scalar 10K</i> on page 3-8 and <i>Starting the Scalar 10K</i> on page 3-7. • If xx yy is not 00 00, xx indicates the rack where the communication failure occurred, which could be a TCL card or an LBI card. Contact GCH.
	Action 2 If the problem is not corrected or persists, contact GCH. For GCH contact information, refer to <i>Getting More Information or Help</i> on page 1-8.

Table 6-2 Service Action Codes (Continued)

Reported SAC	Perform these actions
A3 xx yy	Time out expires on the LSC card waiting for response from one of the auxiliary controllers (LGR, LBI, or TCL).
	Action 1 Contact GCH. For GCH contact information, refer to <i>Getting More Information or Help</i> on page 1-8.
A4 xx yy	A failure was detected when the LSC attempts to communicate with one of the tape drives.
	Action 1 Use the xx yy modifiers to locate the failing tape drive: <ul style="list-style-type: none"> • xx = rack number (1 to 16) • yy = drive location (1 to 48) For the yy modifiers, 1 is the bottom right drive location (viewing from the back of the module) and 48 being the top left drive location. Drives are counted from right to left and bottom to top. Refer to <i>Service Action Codes</i> on page 6-11 for more information on SAC modifiers.
	Action 2 Isolate the failure by requesting drive status from another drive within the rack. Perform this task using the operator panel (Main Menu ► Status ► Drives ► Drive State).
Action 3 Note whether the status comes back OK or fails to come back, then contact GCH. For GCH contact information, refer to <i>Getting More Information or Help</i> on page 1-8.	
A5 xx yy	Time out expires on the LSC card waiting for response from one of the tape drives.
	Action 1 Contact GCH. For GCH contact information, refer to <i>Getting More Information or Help</i> on page 1-8.
B0 xx 00	A home sensor failure was detected in the Tower Module located in rack xx.
	Action 1 Contact GCH. For GCH contact information, refer to <i>Getting More Information or Help</i> on page 1-8.
B1 xx 00	A motion failure was detected in the Tower Module located in rack xx.
	Action 1 Contact GCH. For GCH contact information, refer to <i>Getting More Information or Help</i> on page 1-8.

Table 6-2 Service Action Codes (Continued)

Reported SAC	Perform these actions
B2 xx 00	A Power Amplifier failure was detected in the Tower Module located in rack xx.
	<p>Action 1 Contact GCH. For GCH contact information, refer to <i>Getting More Information or Help</i> on page 1-8.</p>
B5 xx 00	A general tower failure was detected in the Tower Module located in rack xx.
	<p>Action 1 Contact GCH. For GCH contact information, refer to <i>Getting More Information or Help</i> on page 1-8.</p>
D0 00 00	The Library detected that one of its DC Power Supplies has failed.
	<p>Action 1 Use the operator panel to retrieve additional information to determine the failing Power Supply (Main Menu ▶ Service ▶ Diags ▶ P/S Submenu ▶ Library Power). The DC output and AC input of each Power Supply is shown:</p> <p style="text-align: center;">P/S: 1 2 3 4 5 6 7 8 AC : Y Y Y Y Y Y Y Y DC : Y Y Y Y Y Y Y Y Y=OK, N=ERRORS</p> <p>Power Supplies 1 through 4 are N (Standard) configuration, and Power Supplies 5 through 8 are redundant Power Supplies. Y indicates that The DC output and/or AC input of each Power Supply is in good status, while N indicates a failing status.</p>
	<p>Action 2 If a Power Supply's DC output or AC input has a failing status, contact GCH. For GCH contact information, refer to <i>Getting More Information or Help</i> on page 1-8.</p>
D1 00 00	The Library detected that AC input to one bank of the DC Power Supplies is missing.
	<p>Action 1 Contact GCH. For GCH contact information, refer to <i>Getting More Information or Help</i> on page 1-8.</p>

Table 6-2 Service Action Codes (Continued)

Reported SAC	Perform these actions
D2 xx yy	<p>A failure was detected in one of the UDS Power Supplies.</p>
	<p>Action 1 Use the modifier xx yy to locate the failing Power Supply:</p> <ul style="list-style-type: none"> • xx = rack number (1 to 16) • yy = UDS Power Supply location (1 to 4) <p>Refer to <i>Service Action Codes</i> on page 6-11 for more information on SAC modifiers.</p> <p>Action 2 Use the operator panel to retrieve additional information to determine the failing UDS Power Supply (Main Menu ► Service ► Diags ► P/S Submenu ► UDS Power). The screen shows:</p> <pre style="margin-left: 40px;"> P/S: B1 B2 B3 B4 DC : Y Y - - Dual: Y N - - Rack: 04 </pre> <p>Select the rack containing the UDS Power Supply in question:</p> <ul style="list-style-type: none"> • B1 through B4 indicates the Drive bays 1 through 4. • DC indicates the output of each UDS bay: Y=Good, N=Fail. • Dual indicates the status of the UDS P/S: Y=Both P/S's are working, N=One of the UDS P/S supply failed. • A dash (-) indicates the UDS bay is not installed. <p>Locate the rack and the drive bay containing the failing UDS power supply, then contact GCH. For GCH contact information, refer to <i>Getting More Information or Help</i> on page 1-8.</p>
F0 00 00	<p>Failures were detected while running the diagnostic loop test from the LSC card to the LMC card.</p>
	<p>Action 1 Contact GCH. For GCH contact information, refer to <i>Getting More Information or Help</i> on page 1-8.</p>
F1 00 00	<p>Failures were detected while running the diagnostic loop test from the LSC card to the LPN card.</p>
	<p>Action 1 Contact GCH. For GCH contact information, refer to <i>Getting More Information or Help</i> on page 1-8.</p>

Table 6-2 Service Action Codes (Continued)

Reported SAC	Perform these actions
F2 00 00	<p>Failures were detected while running the diagnostic loop test from the LSC card to the LGR card.</p> <p>Action 1 Contact GCH. For GCH contact information, refer to <i>Getting More Information or Help</i> on page 1-8.</p>
F3 00 00	<p>Failures were detected while running the diagnostic loop test from the LSC card to all the sensors on the Gripper assembly.</p> <p>Action 1 Contact GCH. For GCH contact information, refer to <i>Getting More Information or Help</i> on page 1-8.</p>
F4 xx yy	<p>Failures were detected while running the diagnostic loop test from the LSC card to all the sensors on the Insert/Eject station.</p> <p>Action 1 Contact GCH. For GCH contact information, refer to <i>Getting More Information or Help</i> on page 1-8.</p>
F5 00 00	<p>Failures were detected while running the diagnostic loop test from the LSC card to the X-axis home sensors.</p> <p>Action 1 Contact GCH. For GCH contact information, refer to <i>Getting More Information or Help</i> on page 1-8.</p>
F6 00 00	<p>Failures were detected while running the diagnostic loop test from the LSC card to the Y-axis home sensor.</p> <p>Action 1 Contact GCH. For GCH contact information, refer to <i>Getting More Information or Help</i> on page 1-8.</p>
F7 00 00	<p>Failures detected in the LSC card during Power On Self Test.</p> <p>Action 1 Contact GCH. For GCH contact information, refer to <i>Getting More Information or Help</i> on page 1-8.</p>
F8 00 00	<p>Failures detected in the LMC card during Power On Self Test.</p> <p>Action 1 Contact GCH. For GCH contact information, refer to <i>Getting More Information or Help</i> on page 1-8.</p>

Table 6-2 Service Action Codes (Continued)

Reported SAC	Perform these actions
F9 00 00	Failures detected in the LGR card during Power On Self Test.
	Action 1 Contact GCH. For GCH contact information, refer to <i>Getting More Information or Help</i> on page 1-8.
FA 00 00	Failures detected in the LAM1 card during Power On Self Test.
	Action 1 Contact GCH. For GCH contact information, refer to <i>Getting More Information or Help</i> on page 1-8.
FB 00 00	Preventive maintenance is required.
	Action 1 Contact GCH to schedule a Preventive Maintenance. For GCH contact information, refer to <i>Getting More Information or Help</i> on page 1-8.

Resolving a Stuck Accessor

If the accessor is stuck, do the following:

Step 1 Open the AM service door.

Aisle power is disabled.

Step 2 Slightly pull down on the Y-axis belt (to relieve pressure on the gripper) and slide the gripper away from the cartridge slot. If needed, remove the cartridge.

Step 3 Release the Y-axis belt.

Step 4 Push/pull the accessor to the home position (AM service door).

Step 5 Using the operator panel, place the library in **Ready** state (**Main Menu ▶ Mode ▶ Ready**).

 **Note**

When pushing/pulling the accessor, place your hands near the bottom of the accessor to avoid torque on the top and bottom bearings.

Error Log Form

In the event of an error, record the error information from the Error Log screen for any future reference. Refer to *Error Log Dialog* on page 4-26.

Table 6-3 Error Log Reporting

Type	Error	Modifier	Date Error Occurred

Frequently Asked Questions

This section provides a reference of commonly asked questions and their answers.

Question: How do I set the SCSI ID of the Scalar 10K?

Answer: The SCSI ID of the Scalar 10K can be set via the operator panel. Refer to *SCSI Submenu* on page 4-66.

Question: How do I get a password to use Capacity On Demand?

Answer: Contact GCH to receive a password, and refer to *Capacity Submenu* on page 4-79.

Question: What is the Element Addressing scheme for the Scalar 10K?

Answer: The host references source and target designations with element addresses within the Scalar 10K library. Each element within the library has a unique address. For further information refer to *Element Addressing* on page 2-5 of the *Scalar 10K SCSI Reference Manual*.

Question: What is the difference between Default mode, Extended mode, and Multi Media mode?

Answer: The Scalar 10K can recognize different types of barcode labels, depending on what mode it is operating in. Refer to *Understanding Barcodes* on page 5-12.

Question: How do I upgrade the library firmware?

Answer: The Scalar 10K library firmware may only be upgraded by trained personnel. Contact GCH.

Question: What do I do if I lose my password?

Answer: Contact GCH. They can tell you how to reset the password.

Question: What are the barcode limitations/restrictions?

Answer: Barcode labels must be printed according to certain specifications. Refer to *Barcode Labels* on page 5-12.

Question: How do I remove a tape?

Answer: There are several ways to remove tapes from the Scalar 10K. Refer to *Inserting Tape Cartridges* on page 5-6.

Question: Where are the drives located?

Answer: Drives are located in the Control Module or in the Drive Module. Refer to *Control Module* on page 2-6, *Drive Module* on page 2-7, Figure 2-3 on page 2-9, Figure 6-1 on page 7-13, and Figure 6-2 on page 7-14.

Question: How do I set the SCSI/Loop ID's on the Universal Drive Sled (UDS) drives?

The default ID is set for each drive during the installation but can be changed if needed. It is recommended that you keep the default ID's.

Answer: SCSI/Loop ID's can be set via the operator panel. Refer to *ID Dialog* on page 4-88.

Question: Where are the Error Messages defined?

Answer: The Error Messages are defined in the last chapter in this guide. Refer to *Service Action Codes* on page 6-11, *Error Log Form* on page 6-41, and *Error Log Form* on page 6-41.

Question: How do I get help?

Answer: Refer to *Getting More Information or Help* on page 1-8.

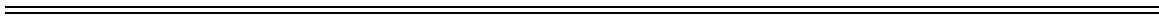

Index

- 3 -

- 3590 drive location numbering 6-14
- 3592 drive location numbering 6-14

- A -

- about screen 4-173
- accessor
 - cartridge 2-12
- Accessor Module 2-6
- accessor submenu 4-126
- acclimating cartridges 5-5
- activate dialog 4-108
- adjust dialog 4-137
- advanced dialog 4-84
- all dialog 4-171
- applying barcode labels 5-13
- associated documents
 - Scalar 10K Maintenance Guide 1-8
 - Scalar 10K Planning Guide 1-8
 - Scalar 10K SCSI Reference Manual 1-8
- audio dialog 4-102
- autoclean
 - drives 5-22

- B -

- barcode label
 - applying 5-13
 - examples 5-15
 - requirements 5-12
 - restrictions 5-13
 - standards 5-12
 - understanding 5-12

- barcode number 2-13
- bays dialog 4-162
- bulk loading cartridges 5-7

- C -

- cartridge accessor 2-12
- cartridges
 - acclimating 5-5
 - ejecting 5-11
 - handling 5-4
 - inserting 5-6
 - inspecting 5-3
 - maintenance 5-3
 - manually bulk loading 5-7
 - processing 5-12
 - storing 5-4
 - transporting 5-5
- clean drives dialog 4-114
- cleaning drives 5-16
- cleaning submenu 4-94
- commands menu 4-40
- config dialog 4-63
- continue dialog 4-158
- Control Module 2-6
- current dialog 4-159

- D -

- database menu 4-60
- date dialog 4-104
- demo dialog 4-169, 4-171
- description
 - help 4-7
 - operator panel 4-5

RMU 2-22
 diags submenu 4-125
 directory structure
 operator panel 4-5
 dismount drives dialog 4-118
 drive dialog 4-164
 drive location numbering
 3590 tape drives 6-14
 3592 tape drives 6-14
 UDS tape drives 6-13
 Drive Module 2-7
 drive state dialog 4-31
 drives
 autoclean 5-22
 cleaning 5-16
 drives dialog 4-96
 drives submenu 4-30, 4-87

- E -

eject clean tape dialog 4-58
 eject cleaning cartridge
 I/E station 5-21
 eject dialog 4-56
 ejecting cartridges 5-11
 element dialog 4-22, 4-61
 emergency shutdown 3-9
 enu 4-29
 error log form 6-41
 error messages 6-1
 Expansion Module 2-6

- F -

fiducial test dialog 4-139
 firmware
 LBI version 4-29
 LGR version 4-29
 library version 4-173
 LSC version 4-29
 RMU version 4-29
 tape drive version 4-112
 TCL version 4-29
 frequently asked questions 6-42

- G -

GCH contact information 1-8
 get/put drives dialog 4-133
 get/put storage dialog 4-130
 getting help 1-8

gripper dialog 4-166

- H -

handling cartridges 5-4
 help 1-8, 4-7
 home dialog 4-140
 Host Dialog 4-83
 host dialog 4-70

- I -

I/E security 4-74
 I/E station 5-6
 ejecting cleaning cartridge 5-21
 inserting cartridges 5-6
 I/E stations dialog 4-39
 indicators
 operator panel 3-5
 initialize dialog 4-107, 4-122
 insert clean tape screen 4-53
 insert screen 4-52
 insert/eject station 2-14
 insert/eject submenu 4-51
 eject clean tape dialog 4-58
 inserting cartridges 5-6
 internal components 2-8
 inventory dialog 4-49, 4-86
 IP dialog 4-83

- L -

library firmware version 4-173
 library microcode version 4-173
 library submenu 4-12, 4-64, 4-99
 locks dialog 4-150
 logs submenu 4-25
 loopback dialog 4-143

- M -

main menu 4-9
 main power switch 1-4
 maintenance
 cartridges 5-3
 manually bulk loading cartridges 5-7
 media
 acclimating 5-5
 ejecting 5-11
 handling 5-4
 inserting 5-6
 inspecting 5-3

maintenance	5-3	P/S submenu	4-152
manually bulk loading	5-7	library power	4-152
processing	5-12	UDS power	4-153
storing	5-4	scanner submenu	4-136
transporting	5-5	adjust dialog	4-137
media dialog	4-60, 4-77, 4-97	fiducial test dialog	4-139
media info dialog	4-35, 4-36	trigger dialog	4-138
menu		self test submenu	4-151
about screen	4-173	tower submenu	4-140
commands menu	4-40, 4-58	home dialog	4-140
insert/eject submenu	4-51	step dialog	4-142
eject dialog	4-56	SAC dialog	4-168
insert clean tape dialog	4-53	start dialog	4-123
insert screen	4-52	teach submenu	4-156
inventory dialog	4-49	bays dialog	4-162
move submenu	4-41	continue dialog	4-158
move media dialog	4-46	current dialog	4-159
position gripper dialog	4-42	drive dialog	4-164
position scanner dialog	4-44	gripper dialog	4-166
park	4-40	new dialog	4-156
database menu	4-60	tape dialog	4-168
config dialog	4-63	verify submenu	4-171
element dialog	4-61	all dialog	4-171
media dialog	4-60	report dialog	4-172
drives submenu	4-30	setup menu	4-64
element dialog	4-22	library submenu	4-64
logs submenu	4-25	advanced dialog	4-84
main screen	4-9	cleaning submenu	4-94
mode dialog	4-10	drives dialog	4-96
service menu	4-123	media dialog	4-97
demo dialog	4-169, 4-171	view dialog	4-98
diags submenu	4-125	drives submenu	4-87
accessor submenu	4-126	scsi dialog	4-88, 4-91, 4-92
move dialog	4-127	host dialog	4-70
step	4-128	inventory dialog	4-86
DI/DO submenu	4-143	media dialog	4-77
locks dialog	4-150	RMU submenu	4-82
loopback dialog	4-143	IP dialog	4-83
sensors submenu	4-145	scsi submenu	4-66
real time screen	4-147	security submenu	4-71
wrap dialog	4-146	I/E security	4-74
gripper submenu	4-129	reset passwords	4-76
get/put drives dialog	4-133	user security	4-72
get/put storage dialog	4-130	trace dialog	4-65
step dialog	4-135	more submenu	4-84
test dialog	4-136	status menu	4-12
library submenu	4-154	drives submenu	4-30
corner moves dialog	4-155	drive state dialog	4-31
storage moves dialog	4-154	media info dialog	4-35, 4-36

I/E stations dialog	4-39
library submenu	4-12
scsi submenu	4-13
system dialog	4-21
towers submenu	4-38
utils menu	4-99
drives submenu	4-106
operations submenu	4-111
clean drives dialog	4-114
dismount drives dialog	4-118
unload drives dialog	4-116
update microcode dialog	4-112
status change submenu	4-106
activate dialog	4-108
initialize dialog	4-107
vary off dialog	4-109
vary on dialog	4-110
towers submenu	4-120
initialize dialog	4-122
status change dialog	4-120
library submenu	4-99
audio dialog	4-102
date dialog	4-104
screen dialog	4-100
snap shot screen	4-104
speed dialog	4-105
time dialog	4-103
messages	
error	6-1
operator intervention	6-4
microcode	
LBI version	4-29
LGR version	4-29
library version	4-173
LSC version	4-29
RMU version	4-29
tape drive version	4-112
TCL version	4-29
mode dialog	4-10
modules	2-5
more submenu	4-84
move dialog	4-127
move media dialog	4-46
move submenu	4-41

- N -

new dialog	4-156
normal shutdown	3-8

- O -

opening service requests	1-8
operations submenu	4-111
operator intervention messages	6-4
operator panel	3-3, 4-5
directory structure	4-5
indicators	3-5
push buttons	3-5

- P -

park	4-40
position gripper dialog	4-42
position scanner dialog	4-44
Problem Box	2-14
protective devices	
main power switch	1-4
push buttons	3-5

- R -

real time screen	4-147
remote management unit	
description	2-22
report dialog	4-172
reset passwords	4-76
RMU	
description	2-22
RMU submenu	4-82

- S -

SAC dialog	4-168
SACs	
modifiers	6-11
table	6-15
understanding	6-11
Scalar 10K restart	3-10
Scalar 10K shutdown	3-8
Scalar 10K startup	3-7
Scalar DLC	2-19
screen dialog	4-100
SCSI Attachment	2-18
SCSI dialog	4-88, 4-91, 4-92
SCSI submenu	4-13, 4-66
sensors submenu	4-145
service action codes	
modifiers	6-11
table	6-15
understanding	6-11
service menu	4-123

service requests, opening 1-8
 setup menu 4-64
 shutdown 3-8
 snap shot screen 4-104
 speed dialog 4-105
 start dialog 4-123
 startup 3-7
 status change dialog 4-120
 status change submenu 4-106
 status menu 4-12
 step 4-128
 step dialog 4-135, 4-142
 storing cartridges 5-4
 symbols and notes 1-6
 system dialog 4-21

- T -

tape cartridges
 overview 2-13
 tape dialog 4-168
 tape drive, updating firmware (microcode) 4-112
 technical support 1-8
 test dialog 4-136
 time dialog 4-103
 Tower Module 2-7
 towers submenu 4-38
 trace dialog 4-65
 transporting cartridges 5-5
 trigger dialog 4-138

- U -

UDS drive location numbering 6-13
 unload drives dialog 4-116
 update microcode dialog 4-112
 user security 4-72
 utils menu 4-99

- V -

vary off dialog 4-109
 vary on dialog 4-110
 verify submenu 4-171
 view dialog 4-98

- W -

WORM tape cartridges 2-8
 wrap dialog 4-146
 Write Once Read Many (WORM) 2-8

- X -

xx 6-11

- Y -

yy 6-11

- Z -

z 6-12

