

adic

**SNC™ 5100 for the
Scalar® 1000 and 10K**

User Guide

 **Advanced Digital Information Corp**

Copyright Notice

© *Copyright* ADIC 2002

The information contained in this document is subject to change without notice.

This document contains proprietary information which is protected by copyright. All rights are reserved. No part of this document may be photocopied, reproduced, or translated to another language without prior written consent of ADIC.

ADIC shall not be liable for errors contained herein or for incidental or consequential damages (including lost profits) in connection with the furnishing, performance or use of this material whether based on warranty, contract, or other legal theory.

All trademarks within this document are the property of their respective owners.

Copyright Notice (Europe)

© *Copyright* ADIC Europe 2002

All rights reserved. No part of this document may be copied or reproduced in any form or by any means, without prior written permission of ADIC Europe, ZAC des Basses Auges, 1 rue Alfred de Vigny, 78112 Fourqueux, FRANCE.

ADIC Europe assumes no responsibility for any errors that may appear in this document, and retains the right to make changes to these specifications and descriptions at any time, without notice.

This publication may describe designs for which patents are pending, or have been granted. By publishing this information, ADIC Europe conveys no license under any patent or any other right.

ADIC Europe makes no representation or warranty with respect to the contents of this document and specifically disclaims any implied warranties of merchantability or fitness for any particular purpose. Further, ADIC Europe reserves the right to revise or change this publication without obligation on the part of ADIC Europe to notify any person or organization of such revision of change.

Every effort has been made to acknowledge trademarks and their owners. Trademarked names are used solely for identification or exemplary purposes, any omissions are made unintentionally.

ADIC and ADIC Europe are trademarks of Advanced Digital Information Corporation.

Advanced Digital Information Corporation	ADIC Europe	ADIC/GRAU Storage Systems GmbH
Tel.: +1 303-705-3900 (USA)	ZAC des Basses Auges	Eschenstraße 3
Fax: +1 303-792-2465 (USA)	1, rue Alfred de Vigny	D-89558 Böhmenkirch, Germany
Customer Assistance: 1-800-827-3822	78112 Fourqueux, France	Tel:+00.800.9999.3822
World Wide Web: http://www.adic.com	Tel.: +33.1.3087.5300	
	Fax: +33.1.3087.5301	

Document number: 6-00020-02

See the release notes for information about system requirements and pre-installation procedure

ADIC CORPORATE • 11431 WILLOWS ROAD, NE • REDMOND, WASHINGTON, USA • 1-800-336-1233
ADIC • 8560 UPLAND DRIVE • ENGLEWOOD, COLORADO, USA • 1-800-827-3822
ADIC • 10 BROWN ROAD • ITHACA, NEW YORK, USA • 1-607-266-4000

Notices

Welcome	1
Safety Notices	1
Safety Inspection	1
Remove AC Power	2
External Machine Check	2
Safety Label Check	2
Fusing Requirements	3
Environmental Notices and Statements	3
Product Recycling	3
Lithium Battery	3
Laser Safety	3
General Restrictions	4
Usage Restrictions	4
Regulatory Notices	4
Electronic Emission Statements	4
Federal Communications Commission (FCC) Statement	4
Industry Canada Compliance Statement	5
European Community Compliance Statement	5
VCCI Notice (Japan Only)	6
BSMI Notice	6
EN 55022 Compliance (Czech Republic Only)	6
CE Notice	7
Documentation	8

Introduction

Overview	9
Configuration Support	10
Address Mapping	10
Interface Protocol Awareness	10
Hardware Product Description and Features	11
Fibre Channel Interfaces	11
Ultra2 SCSI I/O Interfaces	12
SCSI Command Support	13
Ethernet	13
Service Port	13
LED Indicators	14
FC 1-2	14

SCSI 1-4.	15
PWR.	15
RDY.	15
ERR	15
Supported Platforms	15
Supported Devices	16
Operating Specifications	16
Operating Environment	16
Power Consumption.	17
Power Requirements	17

Install the SNC 5100

Pre-installation Procedure	19
Installation Procedure	20
Host Utility Software.	23
Post-Installation	24
Other Installation Issues.	24
Attaching SCSI Devices	24
Maximum Number of LUNs	24
Transfer Rates: Ultra, Fast, and Asynchronous	25
Wide and Narrow SCSI Buses.	25
Table of SCSI Terminology and Limitations	26
SCSI Bus Termination.	27
Problems on the SCSI Bus.	27
Missing terminator at the end of a SCSI bus	28
Excessive termination	28
Multiple devices at the same ID	28
Target device set to initiator's ID	28
Bent pins in a SCSI connector	28
Improper device type	28
Improper terminator type.	28
Inadequate cables.	29
Mixed cable types	29
Unshielded cables	29
Fuses	29
Host Bus Adapter Setup.	29
Installing the SAN Explorer	30
Installing the Host Registration Service	30
Power-Up and Boot Sequence Guidelines.	30

Maintenance Action Plans

Event Codes and Actions	34
Check Event Log	34
Action Reference Table	41
Event Viewing Levels	42
Start MAP	42
Event Code or Obvious Symptom	42
Visually Inspect LEDs	43
Check for Problems on Attached Devices	44
Check Host Versions	44
Check SNC 5100 Product Versions	44
ADIC Management Console version	44
Firmware version	45
Hardware version	45
Quick Component Check	46
Perform Health Check	46
Check the Host Event Log	47
Database Full MAP	47
Device Access MAP	48
Check Fibre Channel Port Status	49
Check SCSI Channel Devices	49
Check Channel Zoning Settings	50
SCSI Channel MAP	50
Get SCSI Information for the SNC 5100	50
Check Attached SCSI Devices from the Service Port	51
Compare Listed versus Physical Devices	52
Compare Listed versus Supported Devices	52
Check SCSI Bus Termination	53
Check for Multiple SCSI IDs	54
Improper Device Type	55
Examine SCSI Cables	56
Examine SCSI Connectors	57
SCSI Health Check	57
SCSI Loop Back Test	58
Testing SCSI Cables	59
Isolating SCSI devices	59
Restore SCSI Setup	60
Fibre Channel MAP	61
Verify Fibre Channel Connections	61
Test GBIC	62

Examine Cables63
Fibre Channel Loop Back Test63
Testing Fibre Channel Optical Cable.64
Replace Fibre Channel Cable65
Replace Fibre Channel Device65
MAP for the SNC 510066
Observe Operational LED Behavior66
Temperature MAP66
Notification of Problems in Temperature Subsystem67
Temperature Warnings or Alarms Received67
Fan Speed is in Warning or Alarm Range68
Power MAP68
Ethernet MAP69
Service Port MAP75
Check the RS-232 Cable76
Check Connection with Boot Messages76
Virtual Private SAN®Scalar Firewall Manager Settings MAP.77
Check Scalar Firewall Manager Access Settings77
Verify Host Access to Devices78

Removal and Replacement Procedures

Handling Electrostatic Discharge-Sensitive Parts81
Removing and Replacing the GBIC82
Removing the GBIC82
Replacing the GBIC.82
Before Removing or Replacing the Unit82
Removing and Replacing the Unit.83
Removing the SNC 5100.83
Replacing the SNC 510084
Final Diagnostic Tests84
Final Test Preparation84
Fibre Channel Tests85
Test Fibre Channel Port 185
Test Fibre Channel Port 285
Test SCSI Port 1 and 2.86
Test SCSI Port 3 and 4.86
Ethernet Test86
Network Setup for the SNC 510087
Updating the SNC 5100.90
Post-Repair Checklist91

Connecting to the Service Port

Service Port Connections95
Connecting the Service Terminal96
Hardware Required96
Initial Setup of HyperTerminal97
Verifying the Connection.97
Updating Firmware and Configurations98
Updating SNC 5100 Firmware98
Saving a Configuration File.99
Loading a Configuration File.99
Zmodem Status Code Table.100
Setting the Time and Date101
Setting the Real Time Clock101
Adding a Host System Running Timeserver102
Disabling the Timeserver Host103
Synchronizing the Real Time Clock with a Timeserver104

Service Port Command Reference

Managing the SNC 5100105
Commands105

Diagnostic Command Reference

Boot Modes187
Entering Diagnostic Mode.187
Restoring Normal Mode188
Special Procedures.188
Health Check188
Manual Health Check188
Event Log Dump189
Retrieving the Code 43 Dump File189
Boot Mode Commands191
Diagnostic Commands.191

POST Error Codes

POST Boot Behavior	197
ROM Init	197
Initial POST	198
Simple Access Test	198
Bitwalk Test	199
Memory Size	199
Pattern Test	199
Address Test	200
Secondary POST	200
Identify and Execute bootrom	200
Start of Bootrom	201
POST Service Menu	201
A - Cold boot from [A]lternate bootrom	202
B - Cold [B]oot from primary bootrom	202
R - [R]eceive new boot image from serial port	203
V- full [V]ersion information	203
Error Displays	203

Startup Message Reference

Bootrom Messages	205
LIC Initialization Messages	206
Final Startup Messages	207

Glossary

Acronyms	209
----------------	-----

Warranty and EULA

ADIC Limited Product Warranty	211
ADIC End User License Agreement	213

INDEX

Notices

Welcome

ADIC is the leading expert in open systems data storage solutions.

Your new SNC 5100 is an intelligent storage networking appliance. It provides a management platform for any-to-any connectivity, increases interoperability, integrates protocol-aware services, and improves reliability, security, and manageability in the Storage Area Network (SAN).

This manual is intended to provide hardware and firmware reference support for ADIC customers and professional services team members.

Safety Notices

The **CAUTION** notice indicates the possibility of damage to a program, device, system, or data.

The **DANGER** notice warns you of conditions or procedures that could result in death or severe personal injury.

DANGER

An electrical outlet that is not correctly wired could place hazardous voltage on metal parts of the system or the devices that attach to the system. It is the responsibility of the user to ensure that the outlet is correctly wired and grounded to prevent an electrical shock.

Safety Inspection

Perform the following safety checks to identify unsafe conditions. Be cautious of potential safety hazards not covered in the safety checks. If unsafe conditions are present, determine how serious the hazards are and whether you should continue before correcting the problem.

Remove AC Power

If the SNC 5100 is not powered off, perform the following steps to remove AC power.

- Step 1.** Perform a controlled system shutdown of attached host systems.
- Step 2.** Set the Power switch on the SNC 5100 to the off position.
- Step 3.** Disconnect the power cord from the power source.

External Machine Check

Perform the following external machine check:

- Step 1.** Verify that the external cover and front bezel of the unit are present and not damaged.
- Step 2.** Check the power cord for damage.
- Step 3.** Check the external signal cable for damage.
- Step 4.** Check the cover for sharp edges, damage, or alterations that expose the internal parts of the device.
- Step 5.** Correct any problems that you find.

Safety Label Check

Perform the following label check:

- Step 1.** Verify that the safety label shown in Figure 1 is installed on the SNC 5100.



Figure 1 Safety Label

Step 2. Check the voltage label on the bottom of the device to ensure it matches the voltage at the power source.

Step 3. Check the voltage level at the power source.

Fusing Requirements

The SNC 5100 power supply has a 3.15 A, 250 VAC time delay fuse on the AC line input, and the AC harness uses an axial lead, 3A, 250 VAC time delay fuse in the neutral line. There are no user-serviceable parts in the SNC 5100.

Environmental Notices and Statements

Product Recycling

This unit contains recyclable materials. These materials should be recycled where processing sites are available and according to local regulations.

Lithium Battery

DANGER

Risk of fire, explosion, or burns. Do not short circuit, crush, heat above 100 C, incinerate, or disassemble the battery.

Laser Safety

This unit may contain a single-mode or multi-mode transceiver, both of which are Class 1 laser products. The transceiver complies with IEC 825-1 and FDA 21 CFR 1040.10 and 1040.11. The transceiver must be operated under the recommended operating conditions.

General Restrictions

The classification is valid only if the module is operated within the specified temperature and voltage limits. The system using the module must provide power supply protection that guarantees that the system power source will cease to provide power if the maximum recommended operation limit or more is detected on the +3.3 V/+5 V at the power source. The operating temperature of the module must be in the temperature range given in the recommended operating limits. These limits guarantee the laser safety.

Usage Restrictions

The optical ports of the modules must be terminated with an optical connector or with a dust plug.

Regulatory Notices

Electronic Emission Statements

This section gives the electronic emission notices or statements for the United States and other countries.

Federal Communications Commission (FCC) Statement

This equipment has been tested and found to comply with the limits for a Class A digital device, pursuant to Part 15 of the FCC Rules. These limits are designed to provide reasonable protection against harmful interference when the equipment is operated in a commercial environment. This equipment generates, uses, and can radiate radio frequency energy and, if not installed and used in accordance with the instruction manual, may cause harmful interference to radio communications. Operation of this equipment in a residential area is likely to cause harmful interference, in which case the user will be required to correct the interference at his own expense.

Properly shielded and grounded cables and connectors must be used in order to meet FCC emission limits. ADIC is not responsible for any radio or television interference caused by using other than recommended cables and connectors or by unauthorized changes or modifications to this equipment. Unauthorized changes or modifications could void the user's authority to operate the equipment.

This device complies with Part 15 of the FCC Rules. Operation is subject to the following two conditions: (1) this device may not cause harmful interference, and (2) this device must accept any interference received, including interference that may cause undesired operation.

Industry Canada Compliance Statement

This Class A digital apparatus complies with Canadian ICES-003.

Avis de conformité à la réglementation d'Industrie Canada: Cet appareil numérique de la classe A est conforme à la norme NMB-003 du Canada.

European Community Compliance Statement

This product is in conformity with the protection requirements of EC Council Directive 89/336/EEC on the approximation of the laws of the Member States relating to electromagnetic compatibility. ADIC cannot accept responsibility for any failure to satisfy the protection requirements resulting from a non-recommended modification of the product, including the fitting of non-ADIC option cards.

This product has been tested and found to comply with the limits for Class A Information Technology Equipment according to European Standard EN 55022. The limits for Class A equipment were derived for commercial and industrial environments to provide reasonable protection against interference with licensed communication equipment.

Caution

This is a Class A product. In a domestic environment, this product may cause radio interference in which case the user may be required to take adequate measures.

Where shielded or special cables (for example, cables fitted with ferrites) are used in the test to make the product comply with the limits.

Properly shielded and grounded cables and connectors must be used in order to reduce the potential for causing interference to radio and TV communications and to other electrical or electronic equipment. Such cables and connectors are available from ADIC authorized dealers. ADIC cannot accept responsibility for any interference caused by using other than recommended cables and connectors.

VCCI Notice (Japan Only)

この装置は、情報処理装置等電波障害自主規制協議会（VCCI）の基準に基づくクラス A 情報技術装置です。この装置を家庭環境で使用すると電波妨害を引き起こすことがあります。この場合には使用者が適切な対策を講ずるよう要求されることがあります。

BSMI Notice

警告使用者：
這是甲類的資訊產品，在居住的環境中使用時，可能會造成射頻干擾，在這種情況下，使用者會被要求採取某些適當的對策。

EN 55022 Compliance (Czech Republic Only)

This device belongs to category B devices as described in EN 55022, unless it is specifically stated that it is a category A device on the specification label. The following applies to devices in category A of EN 55022 (radius of protection up to 30 meters). The user of the device is obliged to take all steps necessary to remove sources of interference to telecommunication or other devices.

Pokud není na typovém štítku poříta uvedeno, úe spadá do třídy A podle EN 55022, spadá automaticky do třídy B podle EN 55022. Pro zařzení zařazené do třídy A (ochranné pásmo 30m) podle EN 55022 platí následující. Dojde-li k rušení telekomunikačních nebo jiných zařzení, je uživatel povinen provést takové opatření, aby rušení odstranil.

CE Notice

Marking by the **CE** indicates compliance of this tape library to the EMC (Electromagnetic Compatibility) directive of the European Community. Such marking is indicative that this tape library meets or exceeds the following technical standards:

- EN 55022:1998 — “Limits and Methods of Measurement of Radio Interference Characteristics of Information Technology Equipment.”
- EN 55024:1998 — “Information technology equipment – Immunity characteristics – Limits and methods of measurements.”
- EN 61000-3-2 — “Harmonic current emissions test.”
- EN 61000-3-3 — “Voltage fluctuations and flicker in low-voltage supply systems test.”
- EN 61000-4-2 — “Electrostatic discharge immunity test.”
- EN 61000-4-3 — “Radiated, radio-frequency, electromagnetic field immunity test.”
- EN 61000-4-4 — “Electrical fast transient/burst immunity test.”
- EN 61000-4-5 — “Surge immunity test.”
- EN 61000-4-6 — “Immunity to conducted disturbances, induced by radio-frequency fields.”
- EN 61000-4-8 — “Power frequency magnetic field immunity test.”
- EN 61000-4-11 — “Voltage dips, short interruptions and voltage variations immunity test.”
- EN 60950:1992 + Amd1:1993 + Amd2:1993 with considerations to Amd.3:1995 — “Safety of Information Technology Equipment including Electrical Business Equipment.”

A “Declaration of Conformity” in accordance with the preceding standards has been made and is on file at ADIC Europe, ZAC de Basses Auges, 1, rue Alfred de Vigny, 78112 Fourqueux, FRANCE.

Documentation

Although the material contained herein has been carefully reviewed, ADIC does not warrant it to be free of errors or omissions. We reserve the right to make corrections, updates, revisions, or changes to the information contained herein.

- Send e-mail to: techdocs@adic.com

Introduction

This chapter describes the SNC 5100. It provides the following information:

- Overview
- Configuration Support
- Hardware Product Description and Features
- Supported Platforms
- Supported Devices
- Operating Specifications

Overview

The SNC 5100 is a 1U high, half-rack width, AC powered storage networking controller.

It is the interface between storage and Open System Host interfaces and provides Fibre Channel to SCSI connectivity. One possible configuration is illustrated in Figure 2.

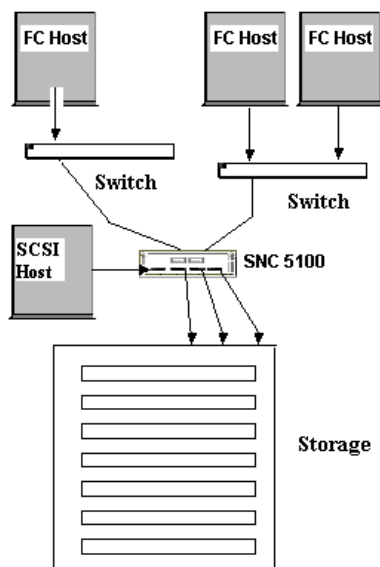

Figure 2 Configuration Overview

Configuration Support

The SNC 5100 provides two Fibre Channel interfaces. The FC interfaces are configured with Giga Bit Interface Converter (GBIC) modules.

In addition, the SNC 5100 has four Ultra2 SCSI interfaces. The Ultra2 interfaces are Low Voltage Differential (LVD).

See Figure 3.

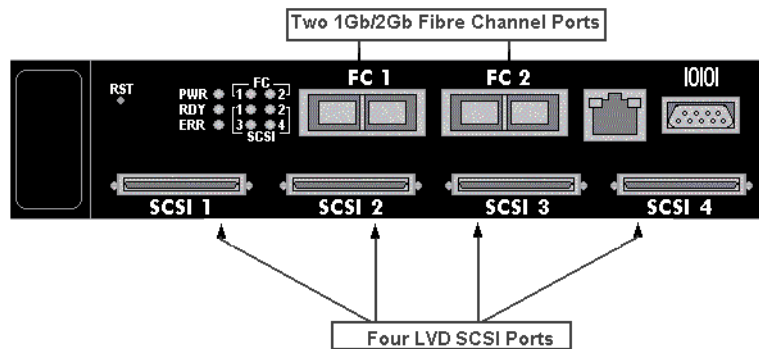

Figure 3 Configuration Detail

Address Mapping

The SNC 5100 maps addresses across and between these different interfaces and preserves the persistency of the address maps across power ups of systems, devices, and the SNC 5100. The SNC 5100 supports the attachment of up to 2048 unique devices across multiple interfaces.

Interface Protocol Awareness

The SNC 5100 processes SCSI-3 and SCSI-2 protocols for disk, tape, and tape medium changer devices. It can report the hosts and devices that are attached to its interfaces. The SNC 5100 has the capability to manage the access security between end points on the Fibre Channel interfaces and the SCSI channels.

Hardware Product Description and Features

This section describes the capabilities of the product and outlines some of the key features of its interfaces.

- An IBM 405GP 200 MHz processor, with integrated instruction and data caches, and internal serial I/O and Ethernet interfaces.
- An Intel 80303 100 MHz Processor, with integrated instruction and data caches.
- QLogic 23x0 Fibre Channel protocol chip
- 32 MB ECC protected SDRAM program memory.
- 128 MB ECC protected SDRAM data buffer memory.
- FLASH memory for operational firmware, power on self-test code, diagnostic functions, and system utilities.
- Non-volatile SRAM for persistent configuration tables and event logs.
- VxWorks™ real-time operating system (RTOS).

Fibre Channel Interfaces

Interfaces for host and device attachment include two 2-Gb/s bi-directional Short Wave connections.

Table 1: Fibre Channel Connections

GBIC speed	Cable Type	Distance
1.062.5 Mb/sec	62.5 μ multimode	300 m
1.062.5 Mb/sec	50 μ multimode	500 m
2.125 Mb/sec	62.5 μ multimode	300 m
2.125 Mb/sec	50 μ multimode	500 m

The Giga-Bit Interface Converter (GBIC) can interoperate with both 2 Gb/sec and 1 Gb/sec data links. The GBIC is hot-swappable and is the only component, except for the SNC 5100 unit itself that is a Field Replaceable Unit (FRU). See “Removing and Replacing the GBIC” on page 82.

Cables should have a duplex SC connector on the GBIC end and a connector appropriate to the HBA in use on the host end.

Fibre Channel interfaces support the following Public and Private Loop modes:

- Target
- Initiator
- Target and Initiator

The maximum number of initiators connected via Fibre Channel is 64 per Fibre Channel port.

Fibre Channel Interfaces also support the following connection options:

- Loop
- Point-to-Point
- Loop Preferred

The Fibre Channel controller is compliant with the following standards and specifications:

- Fibre Channel Arbitrated Loop (FC-AL-2) working draft, rev 6.4, August 28, 1998
- Fibre Channel Fabric Loop Attachment (FC-FLA) working draft, rev 2.7, August 12, 1997
- Fibre Channel Private Loop SCSI Direct Attach (FC-PLDA) working draft, rev 2.1, September 22, 1997
- Fibre Channel -- Tape and Tape Medium Changers (FC-Tape), Rev 1.17, Technical Report, T11/99-069v4
- Fibre Channel protocol SCSI (FCP-SCSI)

Ultra2 SCSI I/O Interfaces

- Four Low Voltage Differential (LVD) Ultra2 SCSI channels with internal termination.
- SCSI channels have automatic speed and width negotiation capability for wide or narrow bus widths and Standard, Fast, Ultra or Ultra2 speeds.
- SCSI channel support for up to 15 SCSI target IDs and up to 32 LUNs per ID (subject to an overall total of 2048 devices). The SNC 5100 uses one

LUN for command and control so that the remaining 2047 LUNs are available for SCSI devices. For each Fibre Channel interface, the SNC 5100 occupies one Fibre Channel ID and all SCSI target devices are available as LUNs on the same Fibre Channel ID.

- The maximum number of initiators that can be connected via SCSI Channel is 1 per SCSI Channel.
- The unit provides four SCSI-3 VHDCI connectors for maximum mechanical reliability.

The SCSI interfaces are compliant with the following SCSI specifications:

- ANSI X3T9.2 375D Rev. 101, SCSI - 2
- ANSI T10/1142D Rev 20b, SCSI-3 Parallel Interface-2

SCSI Command Support

- SCSI-3 SCSI Architecture Model - 2 (SAM-2)
- SCSI-3 SCSI Primary Commands - 2 (SPC-2)
- SCSI-3 SCSI Block Commands - 2 (SBC-2)
- SCSI-3 Stream Commands (SSC)
- SCSI-3 Medium Changer Commands (SMC)
- SCSI-3 Multi-Media Commands - 2 (MC-2)
- SCSI-3 Controller Commands - 2 (SCC-2)

Ethernet

The 10/100 Base-T Ethernet port has an RJ-45 connector for out-of-band management. It can be connected to a network hub, switch, or router using an unshielded twisted-pair Ethernet cable. The Ethernet port complies with the IEEE 802.3 specification.

Service Port

The service port is an RS-232 connection with a 9-pin D-shell connector (DTE). It connects to the host serial port with a 9-pin to 9-pin null-modem cable. It is compatible with serial ports on personal computers.

The service port is used for local service and diagnostics when you use a terminal session to access the shell interface.

The service port is configured at:

- 19,200 Baud
- 8 data bits
- No parity
- One stop-bit
- Hardware Flow Control or Xon/Xoff or other internally detected error conditions

LED Indicators

The User panel of the SNC 5100 provides LEDs that indicate the status and activity of the SNC 5100 and its interfaces.



Figure 4 LEDs

When the SNC 5100 is first turned on, some of the LEDs will be on and others will flash while it is booting.

The following list briefly describes how to interpret the LED signals. See also “POST Error Codes” on page 197.

FC 1-2

For each FC Channel, the LED will be OFF when the Channel is not connected. It will be ON when the Channel is connected to a live Fibre Channel device. It will flash when there is activity on the Channel.

SCSI 1-4

For each SCSI channel, the LED will be OFF when no devices have been detected on the port. It will be ON when a target has been found on the channel. It will flash when there is activity on the channel. The LED will return to the OFF state if the channel is reset.

PWR

The **PWR** (Power) LED will be ON when the SNC 5100 has power. It will flash if the on-board power sensors determine that any of the required supply voltages are out of range.

RDY

The **RDY** (Ready) LED indicates status of Ready. Normally the **RDY** LED flashes when the SNC 5100 has finished booting. If the **RDY** LED remains ON or OFF for more than a few seconds, it means there is a problem.

The **RDY** LED will flash rapidly, four times per second, when the SNC 5100 is running in diagnostic mode.

ERR

The **ERR** (Error) LED indicates that an error condition exists. This may indicate such errors as over-temperature conditions, fan stalled or other internally detected error conditions. See “POST Error Codes” on page 197.

Supported Platforms

The SNC 5100 is a platform-independent product. You can connect a host to the SNC 5100 after you have installed the appropriate host bus adapter and drivers. You can also connect host systems with different operating systems to the SNC 5100 through either SCSI or Fibre Channel.

For a current list of supported platforms, configurations, and host bus adapters, visit www.adic.com.

Supported Devices

The architecture and implementation of the SNC 5100 software has full SCSI-2 and SCSI-3 target and initiator support. The SNC 5100 has support for disk, tape, and medium changer devices. The product supports all these devices with the same firmware. Multiple target device type drivers coexist to support different device types.

For a current list of supported devices, visit www.adic.com.

Operating Specifications

This section contains the physical, electrical, and environmental specifications for the product.

The enclosure is designed for strength, durability, and electromagnetic and radio frequency interference (EMI/RFI) immunity.

The external dimensions are:

- 1.61" high
- 12" deep
- 8.61" wide
- weight: 2.70 kg (~5.93 lb.) with bezel

In order to provide a safety margin and permit adequate cooling, the unit is fitted with a 12 VDC tach-output blower. Should temperatures exceed specifications, an environmental alarm violation is sent and logged in a non-volatile location immune from user erasure, permitting environmental causes of failure to be determined.

Operating Environment

- Operating Temperature: 10° C to 40° C
- Storage Temperature: -40° C to 65° C
- Humidity: 10%-90% Operating, Non-Condensing
5%-95% Non-operating, Non-Condensing

Power Consumption

The power consumption of this product depends on the number and type of installed interface options. Maximum power consumption is 45 watts in active mode. The SNC 5100 can provide up to 3.25 watts of termination power per SCSI channel.

Power Requirements

The power supply status is monitored as part of the Enclosure Monitor Register and is reported by the front panel LED.

For more information on LEDs, see the *ADIC Management Console User Guide*.

- Input voltage range of 85-264 VAC, 47-63 Hz.
- Maximum power draw for the 90 watt supply running at 72% typical efficiency is 65 watts.
- Maximum input current of 1.05 amps max at 120 VAC, 0.51 amps max at 230 VAC.
- Input surge current (cold start) of 17A at 120 VAC, 32A at 230 VAC.

Install the SNC 5100

This section covers installation of the SNC 5100, SCSI devices, and Host Bus Adapter.

Before you or your service representative installs the SNC 5100, you must perform the steps in the "Pre-installation Procedure".

Pre-installation Procedure

It is important that the steps in this procedure are completed before you begin the installation of the SNC 5100. This ensures a successful installation of the product.

Table 2: Pre-Installation Checklist

Step	Actions	Comments and References
1	Verify that the required host platform operating system version is compatible with the installed Fibre Channel Host Bus Adapter (HBA).	For the most current list of supported platforms, required host platform code updates, and information on how to obtain them, visit www.adic.com .
2	Verify that the HBA BIOS and device drivers have been procured and are installed in host system(s).	For the most current list of supported HBAs, the required BIOS and device driver, visit www.adic.com . See "Host Bus Adapter Setup" on page 29.
3	Optionally, install the Host Registration Service on the hosts that will be connected to the SNC 5100.	Consult your service representative. For more information on Access Options, see the <i>ADIC Management Console User Guide</i> .
4	Ensure that all host Fibre Channel cables <ul style="list-style-type: none"> ◦ Have been ordered with the product or ◦ Have been preinstalled and checked and ◦ Are labeled with host system identifier. 	Refer to the HBA Specification provided with your HBA.

Table 2: Pre-Installation Checklist

Step	Actions	Comments and References
5	Label both ends of each SCSI cable with: ° Drive ID and SNC 5100 connector number	None.
6	<p>If you are using the ADIC Management Console to manage the SNC 5100, configure an Ethernet environment. Decide on network parameters:</p> <p>Ethernet port configuration decisions: Static IP address _____ Netmask (if required) _____ User-defined SNC 5100 name (optional) _____</p> <p>You may need to assign a default network gateway address and/or route table entries: _____</p> <p>Caution: Save this configuration information for future reference.</p>	<p>For more information, see the <i>ADIC Management Console User Guide</i>.</p> <p>Obtain the network parameters from your network administrator.</p> <p>Caution: Use of incorrect network parameters can cause problems on the Ethernet network.</p> <p>The default network name is the unit's serial number. If you choose a different name, it becomes the prompt displayed on the service terminal. Choosing a different name may be useful if you have more than one SNC 5100. To change the name, use the "hostNameSet" command on page 138.</p>
7	If you are using the ADIC Management Console to manage the SNC 5100, run the Ethernet cable from the server (the computer that is designated to run the management software's Server) to the network hub.	For more information, see the <i>ADIC Management Console User Guide</i> .

Installation Procedure

The installation checklist has instructions on how to install the SNC 5100 with SCSI attached storage and Fibre Channel attached hosts.

Table 3: Installation Checklist

Step	Actions	Comments and References
1	Acquire information for Ethernet installation.	Refer to Step 6 in Table 2: Pre-Installation Checklist.

Table 3: Installation Checklist

Step	Actions	Comments and References
2	Unpack the SNC 5100. Check the components against the packing slip.	None.
3	Install into rack or on the desktop.	See “” on page 24.
4	Connect the power cord to the SNC 5100.	See “Fuses” on page 29.
5	Connect the service terminal to the Service Port and start a terminal emulation session.	See “Connecting to the Service Port” on page 95 for the required parameters.
6	Run the Ethernet cable from the network hub to the SNC 5100.	<p>If you are using the ADIC Management Console application, you must configure an Ethernet environment.</p> <p>For more information, see the <i>ADIC Management Console User Guide</i>.</p>
7	Power on the SNC 5100 and observe the startup messages on the service terminal.	<p>Look for “done executing startup script” message. See “Startup Message Reference” on page 205.</p> <p>Within one minute, the RDY LED should start flashing once per second. If the “done executing startup script” message is not seen or the RDY LED is not flashing as expected, go the “Start MAP” on page 42.</p>
8	Look for the “done executing startup script” message on the service terminal, then power down the SNC 5100.	None.
9	Connect the SCSI cables from the target devices to the SNC 5100. Turn on the SCSI target devices.	
10	Turn on the SNC 5100.	Within one minute, the RDY LED on the SNC 5100 should start flashing once per second and the “done executing startup script” message should be displayed on the service terminal.

Table 3: Installation Checklist

Step	Actions	Comments and References
11	<p>Configure the Ethernet Port (Host Name, Address, Routes, reboot).</p> <p>Observe Ethernet Link LED.</p>	<p>If you are using the ADIC Management Console, you must configure an Ethernet environment.</p> <p>For more information, see the <i>ADIC Management Console User Guide</i></p> <p>Configure the Ethernet Port using information in Step 6 in Table 2: Pre-Installation Checklist.</p> <p>Refer to “Network Setup for the SNC 5100” on page 87.</p> <p>If the Ethernet Link LED is not on, go to “Ethernet MAP” on page 69.</p>
12	<p>Issue <code>hostTypeShow</code> command from the service terminal to view host type settings for the Fibre Channel ports.</p> <p>If the hosts that will be connected are not the type shown, issue <code>setHost</code> command from the service terminal to set the host type for each Fibre Channel port.</p>	<p>See the "<code>hostTypeShow</code>" command on page 138.</p> <p>See the "<code>setHost [port], "OS"</code>" command on page 162.</p>
13	<p>Power down the FC host(s).</p> <p>Connect the FC cables from the FC HBA(s) to the SNC 5100.</p> <p>Power up the FC host(s).</p>	<p>If the FC1 and/or FC2 Connection Status LED for the attached host(s) is not on, check FC cables. You may have to change the polarity of the FC cables. If the problem persists, go to “Fibre Channel MAP” on page 61.</p>
14	<p>Issue the <code>fcShow</code> command from the service terminal to show the status of the FC interface that is installed and connected.</p> <p>Issue <code>fcShowDevs</code> command from the service terminal to show SCSI target devices that are connected as seen by the Fibre Channel interface.</p>	<p>See the "<code>fcShow [level]</code>" command on page 127.</p> <p>Look for FW State=Ready for each FC interface. If FW State NOT=Ready, go to “Fibre Channel MAP” on page 61.</p> <p>See the "<code>fcShowDevs</code>" command on page 129. If all devices are not shown, go to “SCSI Channel MAP” on page 50.</p>

Table 3: Installation Checklist

Step	Actions	Comments and References
15	Verify all target devices are available to the host system.	Use appropriate host system utilities for disk and tape. See Table 4. If all devices are NOT available, reboot host system(s) and check again. If problem persists, go to "Start MAP" on page 42.

Host Utility Software

Table 4: Host Utility Software

Platform	Host Utility Software Name	Host Utility Software Function
Windows	Disk Administrator SCSI Adapter control panel applet Tape Devices control panel applet	show attached devices show installed scsi adapters show installed tape device drivers
Solaris	st.conf ¹ reboot -- -r ls/dev/rmt	specify LUNs to be scanned for tape devices ¹ rescan show mapped tape devices
AIX	lsdev -Cc tape lsdev -Cc adapter rmdev - dl fcs[n] -R where [n] is the number of the device cfgmgr	list all tape devices list all adapters remove devices no longer present reconfigure
HP-UX	ioscan -C disk	scan for devices
<p>NOTE:</p> <p>¹ Because systems vary it is generally not possible to just replace the existing sd.conf or st.conf with a new one. Therefore you will have to add multiple LUN entries for SCSI ID 0 to sd.conf. After the existing line: name="st" class="scsi" target=0 lun=0; add lines of the form: name="st" class="scsi" target=0 lun=1; until you have as many lines as are needed, one line per storage device or volume. Be sure to increase the LUN number appropriately.</p>		

Post-Installation

The ADIC Management Console application allows you to manage multiple SNC 5100s from any location on your network.

For installation and operating instructions, see the *ADIC Management Console User Guide*.

Other Installation Issues

The SNC 5100 is 8.61" wide x 12.0" deep x 1.61" high.

All the connectors, and the air outlets, are at one end of the unit. The air inlet and power switch at the other. A minimum of 3" clearance is required at the connector end for cables, though 4-5" is recommended. A minimum of 0.75" clearance at the air inlet end and a supply of air at ambient temperature and pressure are required. There are no side clearance requirements.

Attaching SCSI Devices

SCSI devices are attached to any of the SCSI connectors on the rear of the . The device types and speeds, as well as cabling, target IDs, and termination are discussed below.

High quality cables with the correct latches or screws must be used at all times to ensure reliable connections. Cables are not provided with the .

Caution

Ensure that you read this section before you attach any devices to the . A summary table appears at the end of this discussion.

Maximum Number of LUNs

The SNC 5100 supports up to 2048 LUNs.

Caution

Do not attach more than 2048 LUNs to the SNC 5100. Exceeding the 2048 LUN limit will result in unreliable behavior.

Transfer Rates: Ultra, Fast, and Asynchronous

The SCSI protocol defines two methods of data transfer: synchronous and asynchronous. Asynchronous transfers may run as fast as 5 MB/sec, while synchronous transfers may run as fast as 180 MB/sec (Ultra2/3) at block sizes of 256 k. Performance is system and configuration dependent.

The rate of transfer is negotiated between a SCSI initiator, such as the SNC 5100, and each target. For each target device identified during a bus scan, the SNC 5100 will request a transfer rate at the fastest transfer rate supported by the SNC 5100. The target will then reply with the maximum transfer rate it will support.

Caution

In general, devices that are capable of running at Ultra2/3 speeds should not be mixed on a bus with slower devices, since the bus speed will be set to match the slowest device on the bus.

Wide and Narrow SCSI Buses

A SCSI bus may be either narrow (8 bit) or wide (16 bit). The SNC 5100 SCSI buses are all wide, but may be connected to narrow devices with the correct cable adapters.

Although it is possible to mix narrow and wide devices on a single SCSI bus, this configuration is not recommended. If any of the devices supports Ultra2/3 speeds, then a mix of narrow and wide devices is prohibited.

In order for the SNC 5100 to locate and communicate with the devices, each device on the SCSI bus must be assigned a unique target ID. On a wide (16 bit) SCSI bus, the SCSI standard allows for a total of 16 target IDs. On a narrow (8 bit) SCSI bus, the SCSI standard allows for a total of 8 target IDs. There are no requirements about the ordering or position of the target IDs on the SCSI bus. The only requirement is that there be no duplicate target IDs. By default, the SNC 5100 uses ID 7. Thus, peripheral devices may be assigned IDs 0 through 6 and 8 through 15, typically selected by a switch or jumpers. These settings may be changed.

Caution

Make sure you do not assign more than one device on a bus to the same target ID. This will prevent that bus from working properly.

The SCSI protocol also defines a priority-based arbitration method, based on the target ID of the device attaching to the bus. The SCSI ID priority order is, from highest to lowest, 7, 6, 5, 4, 3, 2, 1, 0, 15, 14, 13, 12, 11, 10, 9, 8.

Table of SCSI Terminology and Limitations

The following table (look for updates at <http://www.scsita.org/>) defines the number of devices supported, based on the negotiated transfer type. When reviewing the limitations of a bus, the capabilities of the fastest devices must be considered. The bus length indicates total SCSI bus length, including any internal device cables, rather than the length between any two devices.

Table 5: SCSI Trade Association Terminology

Endorsed Terminology for SCSI Parallel Interface Technology	Max. Bus Speed, MB/Sec	Bus Width, Bits	Max. Bus Lengths , in Meters (1)	Max. Devices
			LVD	
SCSI 1 (2)	5	8	25	8
Fast SCSI (2)	10	8	25	8
Fast Wide SCSI (2)	20	16	25	16
Ultra SCSI (2)	20	8	25	8
Ultra SCSI (2)	20	8	-	4
Wide Ultra SCSI	40	16	25	16
Wide Ultra SCSI	40	16	-	8
Wide Ultra SCSI	40	16	-	4
Ultra2 SCSI (2,3)	40	8	25	8
Wide Ultra2 SCSI (3)	80	16	25	16
Ultra3 SCSI or Ultra 160 (5)	160	16	(4)	16
Ultra320	320	16	(4)	16

Table 5: SCSI Trade Association Terminology**Notes:**

¹The listed maximum bus lengths may be exceeded in Point-to-Point and engineered applications.

²Use of the word "Narrow", preceding SCSI, Ultra SCSI, or Ultra2 SCSI is optional.

³Single-ended is not defined for speeds beyond Ultra.

⁴Not defined for speeds beyond Ultra2.

⁵After Ultra2 all new speeds are wide only.

SCSI Bus Termination

Each end of a SCSI bus must be terminated correctly. The SNC 5100 provides termination on each of its buses. The terminators can be disabled using a jumper on the SNC 5100 motherboard.

The terminators can also be enabled or disabled from the ADIC Management Console. For more information on SCSI Channel configuration, see the *ADIC Management Console User Guide*.

Caution

Improper SCSI bus termination may result in excessive errors on the SCSI bus, and may lead to data corruption or the inability to communicate with target devices.

The SNC 5100 provides termination power on all SCSI buses for external terminators.

Many SCSI target devices have internal terminators. It is imperative that the terminators be disabled for all devices EXCEPT those at the physical ends of the SCSI bus.

Problems on the SCSI Bus

When a SCSI bus fails to operate correctly, it is most often caused by incorrect connections to the SCSI bus. Common problems include:

Missing terminator at the end of a SCSI bus

Check that an external terminator is attached or that the end device has termination enabled.

Excessive termination

Check that all devices other than the end devices have termination disabled.

Multiple devices at the same ID

If two or more devices are configured at the same SCSI ID, only one of those devices will be seen by the SNC 5100, and data transfers to that device will be unreliable. Check that only one device is set to each ID.

Target device set to initiator's ID

If a target device is set to the same ID as the SNC 5100 (ID 7), the bus will be unstable and targets will not be identified. Check that no target devices are set to ID 7, or if one must be set to 7, change the SNC 5100 Initiator ID.

Bent pins in a SCSI connector

The pins in the SCSI connectors are somewhat fragile. Inspect each connector to find pins that were bent when the connector was attached. Replace any cables with bent pins.

Improper device type

A DE device on an SE bus or an SE device on a DE bus will cause the bus to be unusable.

Improper terminator type

A DE terminator on an SE bus or an SE terminator on a DE bus will cause the bus to be unusable.

Inadequate cables

Older cables may not be suitable for running at Ultra speeds. Be sure all cables are rated for Ultra.

Mixed cable types

If a SCSI bus has both round cables and flat ribbon cables, it may suffer problems when running at Ultra speeds. Use the same cable type consistently for all segments of the SCSI bus.

Unshielded cables

An unshielded SCSI cable used external to a cabinet may cause reliability problems, due to interference from other electrical devices. Use only shielded cables.

Fuses

The SNC 5100 has a 3.15A, 250 VAC, time delay fuse on the AC line input, and the AC harness uses an axial lead, 250 VAC time delay fuse in the neutral line. There are no user-serviceable parts in the SNC 5100.

Host Bus Adapter Setup

Hosts are connected to the SNC 5100 through specific Host Bus Adapters (HBAs). The installation procedure varies slightly, depending on which adapter you will be using. The procedure involves these steps:

- Step 1.** Install the adapter in the host system, following the manufacturer's recommendations.
- Step 2.** Power on the host system and update the adapter firmware, if necessary.
- Step 3.** Boot the operating system and install the device driver for the HBA.
- Step 4.** Reboot and verify that the device driver has started and that expected target devices are seen by the operating system.

Step 5. Install optional utility software, if desired.

Perform steps 4 and 5 after the SNC 5100 is installed and connected to the host system.

Installing the SAN Explorer

The SAN Explorer software is only available for hosts running the Windows NT or Windows 2000 operating systems. It allows you to view the LUN mapping through switches to which your SNC 5100 may be attached.

It includes the Host Registration Service. The Host Registration Service provides the SNC 5100 with periodic host status information including the host name, host type and HBA. The default notification period is 15 minutes.

See the readme file on the CD-ROM for installation instructions. For software updates, visit www.adic.com.

Installing the Host Registration Service

The Host Registration Service is available without the SAN Explorer software for host operating systems other than Windows NT or Windows 2000. It provides the SNC 5100 with periodic host status information including the host name, host type and HBA. The default notification period is 15 minutes.

See the readme file on the CD-ROM for installation instructions. For software updates, visit www.adic.com.

Power-Up and Boot Sequence Guidelines

The SNC 5100 scans the SCSI buses after it boots. If you add or remove SCSI devices after the SNC 5100 has booted, it will not detect the changes until you invoke a SCSI rescan or reboot.

Before you turn on or restart the hosts that are connected to the SNC 5100, you must wait until the SNC 5100 has finished booting. You will know that the SNC 5100 has finished booting when the **RDY** LED on the user panel blinks at intervals of one second.

Some operating systems provide you with software methods that allow you to add or remove SCSI devices dynamically after the host has booted. To ensure reliable operation, reboot the host.

If you update SNC 5100 firmware you must reboot in order to use the new firmware. To ensure compatibility between the firmware features or functions and the host, reboot the host.

If you update SCSI device firmware, the SAN Explorer application does not display the new firmware version until you rescan the appropriate SCSI Channel on the SNC 5100.

Maintenance Action Plans

This section describes the Maintenance Action Plans (MAPs) for the SNC 5100. MAPs exist for all of the SNC 5100's component systems.

If it is clear that a particular component system is at fault in a problem situation, go directly to the MAP for that component by consulting Table 6.

If it is not clear which component system is at fault in a problem situation, choose one of the following options:

- Work through the Event Codes and Actions in Table 7 on page 35 in order to determine the appropriate MAP.
- Work through the “Start MAP” on page 42 in order to determine the appropriate MAP.

Table 6: Maintenance Action Plans Troubleshooting Table

Component Subsystem	Go To
If Event Code 42 has been reported	“Database Full MAP” on page 47
If you are unable to access SCSI or Fibre devices	“Device Access MAP” on page 48
If SCSI I/O fails or errors on the SCSI bus are reported	“SCSI Channel MAP” on page 50
If the SAN Connection LED is off or Fibre Channel errors are reported	“Fibre Channel MAP” on page 61
If the SNC 5100 continually reboots or all LEDs are off	“MAP for the SNC 5100” on page 66
If the temperature Warning or Alarm LEDs are on	“Temperature MAP” on page 66
If all LEDs are off or the SNC 5100 fails to respond to any method of management	“Power MAP” on page 68
If Client and Server cannot communicate or the Ethernet LED is off	“Ethernet MAP” on page 69
If the Client is communicating with the Server, but the Service Terminal does not respond	“Service Port MAP” on page 75

Event Codes and Actions

Review all visual observations and Event Codes against Table 7 on page 35.

Check Event Log

- Step 1.** To determine what Events are in the Event Log, follow the procedures in the *ADIC Management Console User Guide*.
- Step 1.** If the ADIC Management Console application is not available, connect a service terminal to the SNC 5100.

For information about how to do this, see “Connecting to the Service Port” on page 95.

- Step 2.** Press the **Enter** key on the service terminal.

If the prompt is not displayed, go to “Service Port MAP” on page 75.

- Step 3.** Issue the `loggerDump` command from the service terminal.

For more information, see the "`loggerDump [number]`" command on page 141.

Messages that look like the ones in Figure 5 display:

```

SN600393 > loggerDump
*** Dumping 10 of 10 records ***
SEQUENCE TIME          CODE  DESCRIPTION
0001  FEB 21 2002 17:58:06  31  NOTICE: LOGGING STARTED
0002  FEB 21 2002 17:58:06  14  CS 1: Rev. 4.11.05 Built Feb  5 2002, 18:03:37
0003  FEB 21 2002 17:58:12  14  VPS 1: Enabled: State = Active, Hosts = 1
0004  FEB 21 2002 17:58:12  14  FCAL 1: External FIFO depth is unknown (0x0700)
0005  FEB 21 2002 17:58:12  14  FCAL 2: External FIFO depth is unknown (0x0700)
0006  FEB 21 2002 17:58:13  14  FCAL 1: LIP Initiated
0007  FEB 21 2002 17:58:13  14  FCAL 2: LIP Initiated
0008  FEB 21 2002 17:58:13  28  USCSI 2: Bus RESET
0009  FEB 21 2002 17:58:13  28  USCSI 4: Bus RESET
0010  FEB 21 2002 17:58:13  14  System 0: ES 1 CC 0/0 Prd 2 Snp 1 HP 1 fMax 254 Rstl 0
SN600393 >

```

Figure 5: Event Log Listing From Service Port

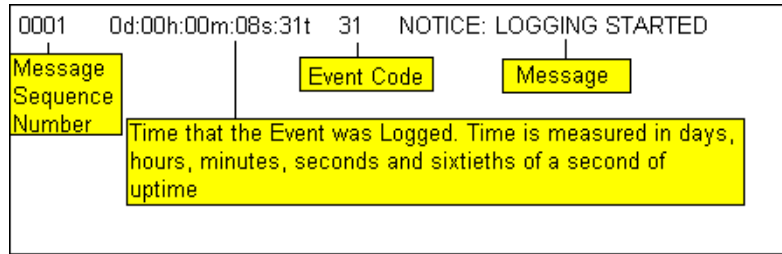

Figure 6: Detail of Event Log Listing From Service Port

Step 4. Check the listed Event Codes against the **Event Code** column of Table 7 on page 35.

See Figure 6 to interpret the log listing.

Step 5. Read across Table 7 to the **Action** column to see the associated Action number.

Step 6. Find the Action number in the **Action** column of Table 8 on page 41.

Step 7. Complete the indicated MAP or action.

Step 8. To see additional log messages, follow the procedure “Event Log Dump” on page 189.

Step 9. If there are no abnormal events, go to “Perform Health Check” on page 46.

Table 7: Event Codes and Actions

Event Code	Viewing Level ¹	Default Trap Threshold	Description	Action ²
			Visual Observations	
N.A.	N.A.	N.A.	All LEDs are off	5
N.A.	N.A.	N.A.	RDY LED not blinking once per second after power has been on for one minute	3
N.A.	N.A.	N.A.	Temperature Warning LED on	4
N.A.	N.A.	N.A.	Temperature Alarm LED on	4
N.A.	N.A.	N.A.	SNC 5100 not responding	3

Table 7: Event Codes and Actions

Event Code	Viewing Level¹	Default Trap Threshold	Description	Action²
N.A.	N.A.	N.A.	Persistent reboots	3
N.A.	N.A.	N.A.	Host application error message or host log entry indicates SCSI target error	12
N.A.	N.A.	N.A.	Host cannot access attached devices	12
N.A.	N.A.	N.A.	SAN Connection LED off although cables are attached and host systems are on and have booted	2
N.A.	N.A.	N.A.	Heartbeat failure	7
N.A.	N.A.	N.A.	fcShow command returns Firmware State = Sync Lost	2, 0
N.A.	N.A.	N.A.	ADIC Management Console failure	7
N.A.	N.A.	N.A.	Service terminal connection failure	8
			Generic Event Descriptions	
8	2	0	Sense data recorded following a check condition Caution: Normally, the host system will request and process send data and then perform error recovery	0
9	1	0	LUN reports a “unit attention” condition on a non-removable media device	0
11	1	1	ADIC Management Console reports a temperature change (event message indicates the change to High, Very High, Reduced, to High, or OK)	4
13	1	1	SNC 5100 is shutting down as requested by the ADIC Management Console (a Restart was requested)	0
14	0	0	Additional status information used for diagnostics	0

Table 7: Event Codes and Actions

Event Code	Viewing Level ¹	Default Trap Threshold	Description	Action ²
16	1	1	A SCSI bus reports an unexpected interrupt	1
17	1	1	Fibre Channel interface reports a LIP reset was received from a host	0, 2
18	1	1	Fibre Channel interface reports a system error	2
19	1	1	Fibre Channel interface reports an error processing a request	2
20	1	1	Fibre Channel interface reports an error processing a response	2
21	1	1	SNC 5100 processor memory fault detected	1, 2, 3
22	1	10	Fibre Channel interface detected a LIP	2
23	2	0	Fibre Channel interface reports a loop up	0
24	2	0	Fibre Channel interface reports a loop down	0
25	1	1	SNC 5100 PCI bus parity error detected	3, 2, 1
26	1	1	SNC 5100 PCI interface error detected	3, 2, 1
27	2	0	A device has been added to a SCSI bus	0
28	1	0	A SCSI bus reports a reset has been detected	0
29	1	1	SNC 5100 has added a device to its configuration table Caution: The trap is held off until the SNC 5100 has been up for 60 seconds	0
30	1	1	SNC 5100 has removed a device from its configuration	0, 1, 2
31	2	0	SNC 5100 logging service has started	0

Table 7: Event Codes and Actions

Event Code	Viewing Level ¹	Default Trap Threshold	Description	Action ²
33 ³	1	1	An interface has detected a bus fault (event message indicates the specific interface)	1, 2
34 ³	1	1	An interface has detected a device fault (event message indicates the specific interface)	1, 2
35	1	1	A SCSI interface reported an unexpected disconnect by a device	1
36	1	1	A parity error was detected on a SCSI bus	1
37	2	0	Fibre Channel Port Database change detected	0
39	1	1	Directory Server on Fabric has changed	0
40	1	1	Maximum LUN limit has been exceeded	10
41	1	0	Fibre Channel transfer failure (Caution: error recovery may have succeeded)	0
42	1	1	Maximum device limit has been exceeded (persistent Address Map database is full)	10
43	1	1	Fibre Channel interface driver reported debug file dump (event log contains further information)	13
58	1	1	Power has returned to Nominal from Warning or Alarm Stage	0
59	1	1	Power has entered Warning Range from Nominal Range (Power falling) or Alarm Range (Power improving)	5
60	1	1	Power has entered Alarm Range	5

Table 7: Event Codes and Actions

Event Code	Viewing Level¹	Default Trap Threshold	Description	Action²
61 ⁴	1	1	Inlet Air, Outlet Air, or I/O Processor temperatures have entered Nominal Range from a Warning or Alarm Range	0
62 ⁴	1	1	Inlet Air Temperature has entered Warning Range from Nominal Range (heating up) or Alarm Range (cooling down)	4
63	1	1	Inlet Air Temperature has entered Alarm Range	4
64 ⁴	1	1	Outlet Air Temperature or I/O Processor Temperature has entered Warning Range from Nominal or Alarm Ranges	4
65	1	1	Outlet Air Temperature or I/O Processor Temperature has entered Alarm Range	4
66	1	1	Fan is operating in Nominal Range after operating in a fault state	0
67	1	1	Fan speed has entered Warning Range (Tachometer fans only)	4
68	1	1	Fan speed has entered Alarm Range (Tachometer fans) or is stalled (rotor stall fans)	4
70 ⁵	1	1	Firmware upload completed	0
71 ⁵	1	1	SNC 5100 restart completed	0
72	1	1	Maximum number of initiators has been exceeded	0
150	1	1	The event log is about to overwrite the earliest events	0
			Health Check Event Descriptions	
100	1	1	Power supply is out of specification	5

Table 7: Event Codes and Actions

Event Code	Viewing Level ¹	Default Trap Threshold	Description	Action ²
102	1		Temperature change detected since the last report (event message indicates the change to High, Very High, Reduced to High, or OK)	4, 0
106	1	1	Fibre Channel interface failed Health Check	2
107	1	1	SCSI interface failed Health Check	1
109	1	1	Target device failed Health Check	1
110	1	1	Fibre Channel link status changed	0, 2
111	1	1	Fibre Channel transfer failures detected since the last report Caution: error recovery may have succeeded	0
112	1	1	Blower/Fan is running in Warning or Alarm Range	4
113	1	1	Power is running in Warning or Alarm Range	5
114	1	1	Temperature is running in Warning or Alarm Range	4
115	1	1	Network is running at 10 Mb/sec	7
			Heartbeat Event Descriptions Caution: These event codes are not logged in the Event Log. Notification of these events occurs from the ADIC Management Console. For more information on Heartbeat, see the <i>ADIC Management Console User Guide</i> .	
200 ⁵	N.A.	N.A.	The Server could not verify the connection to the SNC 5100	7,3
201 ⁶	N.A.	N.A.	The Client could not communicate with the Server	7,9
202 ^{6,7}	N.A.	N.A.	The Server could not communicate with the Client	7,9

Table 7: Event Codes and Actions

Event Code	Viewing Level ¹	Default Trap Threshold	Description	Action ²
203 ^{6,8}	N.A.	N.A.	Heartbeat communication restored	0
<p>Notes:</p> <p>¹See Table 9 on page 42.</p> <p>²See Table 8 on page 41.</p> <p>³Default Trap Threshold settings are explained “Events” in the ADIC Management Console User Guide.</p> <p>⁴Check the Event Log to find out which interface (FCAL or SCSI) caused this event. Then use the appropriate action number.</p> <p>⁵This trap signals a change in state. A string sent with the trap will indicate the nature of the previous state.</p> <p>⁶Events not logged in SNC 5100 Event Log.</p> <p>⁷Not Reported. View the Server Log.</p> <p>⁸Event reported only when ADIC Management Console 2.7 or above is running</p>				

Action Reference Table

Numerical references from the **Action** column in Table 7: Event Codes and Actions are associated with the appropriate MAP in Table 8: Action Reference Table.

Table 8: Action Reference Table

Action Number	Action
0	No action necessary
1	Go to “SCSI Channel MAP” on page 50
2	Go to “Fibre Channel MAP” on page 61
3	Go to “MAP for the SNC 5100” on page 66
4	Go to “Temperature MAP” on page 66
5	Go to “Power MAP” on page 68

Table 8: Action Reference Table

Action Number	Action
7	Go to “Ethernet MAP” on page 69
8	Go to “Service Port MAP” on page 75
9	Contact your network administrator
10	Reduce the number of target devices attached to the SNC 5100
11	Go to “Start MAP” on page 42
12	Go to “Device Access MAP” on page 48
13	Go to “Retrieving the Code 43 Dump File” on page 189

Event Viewing Levels

Numerical equivalents for the Event viewing levels from the **Viewing Level** column of Table 8 are explained in Table 9.

Table 9: Event Viewing Levels

Number	Level	Explanation
0	Notice	Events recorded in the Event Log but not displayed by the Event Viewer
1	Warning	Includes events that should always be reported, such as device removals, and changes to temperature or power systems
2	Information	Includes events that might result in later problems

Start MAP

Gather as much information as possible before performing a repair action. When gathering information, you may need to connect the service terminal to the service port. See “Connecting to the Service Port” on page 95.

For the latest information on the SNC 5100, visit www.adic.com.

Event Code or Obvious Symptom

Either an Event Code has been reported by the ADIC Management Console or an error has been observed by other means.

For more information on Events, see the *ADIC Management Console User Guide*.

If the event code is known, go to Table 7, “Event Codes and Actions,” on page 35 with that event code and perform the recommended action.

If the symptom is obvious, go to Table 6, “Maintenance Action Plans Troubleshooting Table,” on page 33.

If the event code or error symptom is not known, go to “Event Codes and Actions” on page 34.

Otherwise, proceed to "**Visually Inspect LEDs**".

Visually Inspect LEDs

Use this procedure to visually inspect the LEDs.

Step 1. Observe front-panel SNC 5100 LED status indicators.

For information about expected LED behavior, see “LED Indicators” on page 14.

If the **RDY** LED is flashing as expected but the SCSI, Ethernet and SAN Connection LEDs are off, the SNC 5100 may have been left in diagnostic mode.

The device drivers for SCSI, Fibre Channel and Ethernet interfaces are disabled when in diagnostic mode.

If the command prompt on the service terminal is `diagmode >`, return the SNC 5100 to normal mode by entering the `normalBoot` command on the service terminal.

For more information, see “Boot Modes” on page 187.

Step 2. Check LED observation against Table 7, “Event Codes and Actions,” on page 35.

The **Visual Observations** area at the beginning of the Table includes several descriptions of situations signalled by LED states.

Step 3. Refer to Table 8, “Action Reference Table,” on page 41 and complete the action.

Step 4. If LED observations did not solve the problem, proceed to "**Check for Problems on Attached Devices**".

Check for Problems on Attached Devices

Check the following in order to find problems on attached devices:

- LEDs
- Display panels
- Firmware levels
- Operability

Check Host Versions

Check the following in order to find problems on attached Hosts:

- Operating system version
- Service pack version
- Hot-fix version
- HBA hardware version
- HBA firmware version
- HBA device driver version

If an update is required, perform the update.

For an updated list of supported SNC 5100 host platforms and Fibre Channel Host Bus Adapters, visit www.adic.com.

Check SNC 5100 Product Versions

For an current list of required updates, visit www.adic.com.

ADIC Management Console version

Use this procedure to check the version level of the ADIC Management Console application.

Step 1. Start the ADIC Management Console Server and Client.

For installation and operating instructions, as well as access to version information, see the *ADIC Management Console User Guide*.

Step 2. If an update is needed, download the update from www.adic.com, and perform the update.

Firmware version

Use this procedure to check the firmware version level.

Step 1. Connect a service terminal to the SNC 5100.

For information about how to do this, see “Connecting to the Service Port” on page 95.

Step 2. Press the **Enter** key on the service terminal.

If the prompt is not displayed, go to “Service Port MAP” on page 75.

Step 3. Issue the `showVersions` command.

For more information, see the "`showVersions`" command on page 170.

Step 4. If an update is required, download the update from www.adic.com, and perform the update.

Hardware version

Use this procedure to check the hardware version information.

Step 1. Connect a service terminal to the SNC 5100.

For information about how to do this, see “Connecting to the Service Port” on page 95.

Step 2. Press the **Enter** key on the service terminal.

If the prompt is not displayed, go to “Service Port MAP” on page 75.

Step 3. Issue the `sysVpdShow` command.

For more information, see the "`sysVpdShow` or `sysVpdShowAll`" command on page 175.

Step 4. Report this information to your service representative, if you are asked for it.

Quick Component Check

Use this procedure to check system components:

Step 1. Connect a service terminal to the SNC 5100.

For information about how to do this, see "Connecting to the Service Port" on page 95.

Step 2. Press the **Enter** key on the service terminal.

If the prompt is not displayed, go to "Service Port MAP" on page 75.

Step 3. From the service terminal, enter the `showBox` command.

For more information, see the "`showBox`" command on page 170.

Step 4. If an installed component does not show up in the display, go to the correct MAP.

For example, if a SCSI interface is missing, go to ""SCSI Channel MAP"" on page 50.

If a Fibre Channel is missing, go to ""Fibre Channel MAP"" on page 61.

Step 5. If all components display properly, proceed to "**Perform Health Check**".

Perform Health Check

Step 1. Stop all I/O.

Step 2. Remove the Ethernet cable if installed.

Step 3. Connect a service terminal to the SNC 5100.

For information about how to do this, see “Connecting to the Service Port” on page 95.

Step 4. Press the **Enter** key on the service terminal.

If the prompt is not displayed, go to “Service Port MAP” on page 75.

Step 5. From the service terminal, issue the `hlthChkNow` command.

For other commands associated with healthchecks, see terms beginning with the `hlthChk` prefix in “Service Port Command Reference” on page 105.

Step 6. Check the results displayed on the service terminal to determine the status of the interfaces and attached devices. If a failure is indicated, perform the appropriate MAP.

Check the Host Event Log

Check the event log on the Fibre Channel host. Look for the most recent entries and check to see if there are any Fibre Channel HBA driver errors. If there are, go to “Fibre Channel MAP” on page 61.

Database Full MAP

Perform these steps if Event Code 42 is reported. Event Code 42 indicates that the persistent address map database is full.

There cannot be more than 2048 devices in the database. If devices were moved to different ports or channels, Event Code 42 can be reported, even when fewer than 2048 devices are actually present.

Use the following procedure to free up database entries that are no longer needed, and keep the devices that are currently attached at the same Assigned LUNs.

Caution:

Use this procedure only when you are sure that the devices you are interested in are connected and available to the SNC 5100. Devices

that are not currently attached will be removed from the database. You must reboot the SNC 5100 after performing this procedure for the changes to take effect.

Step 1. Connect a service terminal to the SNC 5100.

For information about how to do this, see “Connecting to the Service Port” on page 95.

Step 2. Press the **Enter** key on the service terminal.

If the prompt is not displayed, go to “Service Port MAP” on page 75.

Step 3. From the service terminal, enter the `mapShowDatabase` command to display the contents of the database.

For more information, see “mapShowDatabase” on page 146.

Step 4. From the service terminal, enter the `mapShowDevs` command to display LUN assignments for the attached devices that have been mapped.

For more information, see the "`mapShowDevs`" command on page 147.

Step 5. From the service terminal, enter the `mapWinnowDatabase` command to remove LUN assignments for devices that no longer need to be kept.

For more information, see the "`mapWinnowDatabase`" command on page 148.

Step 6. Reboot the SNC 5100.

Step 7. After the SNC 5100 has finished booting, repeat steps 3 and 4 to verify that all attached devices have been mapped.

Device Access MAP

Perform these steps if a host is not able to access SCSI or Fibre Channel devices.

Step 1. Connect a service terminal to the SNC 5100.

For information about how to do this, see “Connecting to the Service Port” on page 95.

Step 2. Press the **Enter** key on the service terminal.

If the prompt is not displayed, go to “Service Port MAP” on page 75.

Check Fibre Channel Port Status

Step 1. Enter the `fcShow` command from the service terminal.

For more information, see the "`fcShow [level]`" command on page 127.

If the `fcShow` command does not display a Firmware State of **Ready** for the attached Fibre Channel SAN connections, go to “Fibre Channel MAP” on page 61.

Step 2. If a Fibre Channel host should have access to SCSI Channel devices, verify that the FC port mode is **Target**.

The SNC 5100 Fibre Channel ports are set by default to **Target** mode. If the port mode for the host connection was changed to **Initiator**, the host will not be able to see the SCSI devices.

For more information on setting Channel modes, see the *ADIC Management Console User Guide*.

Step 3. If the host should have access to devices on a Fibre Channel, verify that the FC port mode is set to **Initiator** or **Target and Initiator**.

If the port mode for the host connection is set to **Target**, the host will not be able to see the attached Fibre Channel devices.

For more information on setting Channel modes, see the *ADIC Management Console User Guide*.

Check SCSI Channel Devices

Enter the `scsiShow` command from the service terminal.

For more information, see the "`scsiShow`" command on page 160.

If all of the attached SCSI devices are not displayed, go to “SCSI Channel MAP” on page 50.

Check Channel Zoning Settings

Step 1. Enter the `fcShowDevs` command from the service terminal.

For more information, see the "`fcShowDevs`" command on page 129.

Look at the display for each Fibre Channel interface. If all of the SCSI devices are displayed under each Fibre Channel interface, then host access to SCSI devices is not being restricted by Channel Zoning.

Step 2. Use the ADIC Management Console to change Channel Zoning settings.

For information on Channel Zoning, see the *ADIC Management Console User Guide*.

SCSI Channel MAP

Perform these steps if:

- Errors are reported on the SCSI bus
- SCSI I/O fails to operate
- Parity errors are detected on the SCSI bus
- SCSI device reports unit attention on non-removable device
- Unexpected SCSI bus reset occurs
- Unexpected SCSI disconnect reported by a SCSI device

Get SCSI Information for the SNC 5100

Step 1. Connect a service terminal to the SNC 5100.

For information about how to do this, see “Connecting to the Service Port” on page 95.

Step 2. Press the **Enter** key on the service terminal.

If the prompt is not displayed, go to “Service Port MAP” on page 75.

Step 3. If the SNC 5100 is off, then turn it on.

Step 4. Verify that the **RDY** LED is blinking once per second.

As the SNC 5100 is booting, several status messages should be displayed on the service terminal. The last status message is “Done executing startup script”.

If no status messages are displayed, go to “Service Port MAP” on page 75.

Step 5. Enter the `showBox` command from the service terminal.

For more information, see the "`showBox`" command on page 170.

Step 6. Write down the information for each SCSI channel.

Example:

```
SCSI -1 requires Low Voltage Differential cable
```

Step 7. If the SCSI interfaces are not all displayed, replace the SNC 5100.

Go to “Before Removing or Replacing the Unit” on page 82.

Continue through “Replacing the SNC 5100” on page 84.

Exit this MAP.

If the SCSI interfaces display properly, go to "**Check Attached SCSI Devices from the Service Port**".

Check Attached SCSI Devices from the Service Port

Caution

The SNC 5100 supports up to 2048 LUNs. If more than 2048 LUNs are attached, unreliable behavior will result. The SNC 5100 takes up one LUN (0) as its Command and Control LUN. Therefore, only 2047 LUNs are available to the user.

Step 1. Issue the `scsiShow` command from the service terminal to display a list of attached SCSI devices.

For more information, see the "`scsiShow`" command on page 160.

Step 2. For each SCSI channel, make a list of attached devices. Include SCSI device ID, manufacturer, and device status/flags.

Step 3. Go to "[Compare Listed versus Physical Devices](#)".

Compare Listed versus Physical Devices

For each SCSI channel, compare the list of attached devices with the physical devices.

If any of the physical devices are not shown, go to "Check SCSI Bus Termination" on page 53.

If all the physical devices are shown, go to "[Compare Listed versus Supported Devices](#)".

Compare Listed versus Supported Devices

Step 1. Compare the attached devices to the list of supported devices listed.

Step 2. If the attached devices are all supported, go to "SCSI Loop Back Test" on page 58.

If any attached devices are not supported, report them to the system administrator for possible replacement.

Caution

If all other diagnostic procedures fail to isolate a SCSI problem, and there are unsupported SCSI devices attached to the SNC 5100, those devices will need to be removed or replaced.

Check SCSI Bus Termination

Caution

If in this procedure you determine that you need to remove a SCSI cable or terminator, all I/O to the SNC 5100 must be stopped and the SNC 5100 must be turned off.

- Step 1.** Verify the termination for the end device attached to the channel in question.

The last physical device on a chain of SCSI devices needs to be terminated.

If the end device has internal termination, be sure it is enabled.

Otherwise check that an external terminator is attached to the device.

A Differential (DE) terminator on a Single Ended (SE) bus or an SE terminator on a DE bus will cause the bus to be unusable.

- Step 2.** Verify the termination for the other devices attached to the channel in question.

Check that all SCSI devices other than the end devices have internal termination disabled.

A Differential (DE) terminator on a Single Ended (SE) bus or an SE terminator on a DE bus will cause the bus to be unusable.

- Step 3.** If there are SCSI termination problems, power down the SNC 5100 down and correct them.

If you corrected SCSI termination problems, go to "[SCSI Health Check](#)".

If SCSI termination is OK, go to "[Check for Multiple SCSI IDs](#)".

- Step 4.** If you powered down the SNC 5100 down, turn it back on.

Check for Multiple SCSI IDs

If two or more devices on the same SCSI channel are configured at the same SCSI ID, only one of those devices will be seen by the SNC 5100. Data transfers to that device will be unreliable.

Caution

If in this procedure you determine that you need to correct any SCSI IDs, all I/O to the SNC 5100 must be stopped and the SNC 5100 must be turned off.

- Step 1.** Enter the `scsiShow` command from the service terminal.
- For more information, see the "`scsiShow`" command on page 160.
- Step 2.** Write down the SCSI IDs of all devices connected to each SCSI channel.
- Step 3.** Check that only one device is set to each ID for each SCSI channel.
- Assign a new SCSI ID to any conflicting target device.
- Step 4.** Check that for each SCSI Channel, no devices are set to ID 7 except the SNC 5100 channel ID.
- If a target device is set to the same ID as the SNC 5100 (ID 7), the bus will be unstable and data corruption may result.
- Step 5.** If you do not need to correct any SCSI IDs, go to "**Improper Device Type**".
- Step 6.** If you corrected any SCSI IDs, reboot the SNC 5100.
- Step 7.** After it finishes booting, enter the `scsiShow` command.
- For more information, see the "`scsiShow`" command on page 160.
- Step 8.** Compare the list of attached devices with the physical devices.
- If not all of the physical devices are shown, go to "**Improper Device Type**".
- If all of the physical devices are shown, go to "**SCSI Health Check**".

Improper Device Type

- Step 1.** Check to be sure that all the devices attached to a single SCSI bus are of the same type.

Only low voltage differential devices must be attached to low voltage differential SCSI channels.

When a mix of Ultra2/3 SCSI and Ultra SCSI devices are connected to a single bus, the bus will run at the Ultra SCSI speed. Because the bus will auto-adjust to the slowest speed, it is not recommended that you run both Ultra2/3 SCSI and Ultra SCSI devices on the same bus.

Caution

If in this procedure you determine that you need to replace a SCSI device, all I/O to the SNC 5100 must be stopped and it must be turned off.

- Step 2.** Replace any improper SCSI device with a proper device.

- Step 3.** Reconnect the SCSI cable.

- Step 4.** If you do not have to replace an improper device, go to "[Examine SCSI Cables](#)".

If you replaced any devices, reboot the SNC 5100.

- Step 5.** After the SNC 5100 finishes booting, enter the `scsiShow` command from the service terminal.

For more information, see the "`scsiShow`" command on page 160.

- Step 6.** Compare the list of attached devices with the physical devices.

If not all of the physical devices are shown, go to "[Examine SCSI Cables](#)".

If all of the physical devices are shown, go to "[SCSI Health Check](#)".

Examine SCSI Cables

Caution

If in this procedure you determine that you need to remove a SCSI cable, all I/O to the SNC 5100 must be stopped and the SNC 5100 must be turned off.

Step 1. Look for damaged cables.

Check for breaks in the cable jacket, exposed or frayed cable shield, exposed or broken wires.

Step 2. Replace any damaged cables.

Step 3. Look for inadequate cables.

Older SCSI cables may not be suitable for running at Ultra2/3 speeds. Be sure all cables are rated for Ultra2/3.

Step 4. Replace any cables not suitable for running at Ultra 2/3 speeds.

Step 5. Check for mixed cable types.

If a SCSI bus has both round cables and flat ribbon cables, it may suffer problems when running at Ultra2/3 speeds.

Use the same cable type consistently for all segments of the SCSI bus.

Step 6. Replace any cables that are of the wrong type.

Step 7. Check for unshielded cables.

An unshielded SCSI cable used external to a cabinet may cause reliability problems, due to interference from other electrical devices.

Step 8. Replace all unshielded cables.

If no cables are replaced, go to **"Examine SCSI Connectors"**.

If cables were replaced, go to **"SCSI Health Check"**.

Examine SCSI Connectors

Caution

Before removing a SCSI cable, all I/O to the SNC 5100 must be stopped and the SNC 5100 must be turned off.

- Step 1.** Inspect each connector to find out if pins were bent when the connector was attached.
- Step 2.** Replace any cables that have bent pins.
- Step 3.** If you did not have to replace or re-secure a SCSI cable, go to **"SCSI Loop Back Test"**.
- Step 4.** If you replaced or re-secured a SCSI cable, turn on the SNC 5100.
- Step 5.** After it finishes booting, enter the `scsiShow` command from the service terminal.

For more information, see the `scsiShow` command on page 160.

- Step 6.** Compare the list of attached devices with the physical devices.
If not all of the physical devices are shown, go to **"SCSI Loop Back Test"**.
If all of the physical devices are shown, go to **"SCSI Health Check"**.

SCSI Health Check

- Step 1.** Perform a Health Check.
For more information, see "Perform Health Check" on page 46.
- Step 2.** Check the Event Log for SCSI errors.
For more information, see "Check the Host Event Log" on page 47.
- Step 3.** Perform a component check.
For more information, see "Quick Component Check" on page 46.
- Step 4.** If errors are still indicated, go to **"SCSI Loop Back Test"**.
If no errors are reported, exit this MAP.

SCSI Loop Back Test

Caution

Before performing diagnostics, all FC and SCSI cables must be disconnected from the SNC 5100. Before changing any SCSI cables, all I/O to the SNC 5100 must be stopped and the SNC 5100 must be turned off. Do not perform SCSI loop back tests on SCSI channels that are attached to SCSI target devices. If you do this, you will corrupt the data on the device.

Step 1. If the SNC 5100's command prompt on the terminal is not `diagmode >`, enter the `diagBoot` command on the service terminal

For more information, see "Entering Diagnostic Mode" on page 187.

Step 2. Power down the SNC 5100.

Step 3. In addition to the suspect SCSI channel, choose one of the other SCSI channels to use for the loop back test.

Step 4. Label and remove those cables.

Step 5. Connect a short SCSI loopback test cable to those two SCSI channels.

Step 6. Power on the system.

Step 7. Wait for the SNC 5100 to finish booting.

Step 8. Enter the `scsiChannelTest(1,2)` command. The following example shows a loop back test on SCSI channels 1 and 2.

Example:

```
diagmode > scsiChannelTest (1,2)
SCSI-1 -> SCSI-2 [#####] 10 iterations PASSED
SCSI-2 -> SCSI-1 [#####] 10 iterations PASSED
value = 0 = 0x0
```

Step 9. If the SNC 5100 returns a PASSED status, go to "**Testing SCSI Cables**".

Testing SCSI Cables

If the cables of the devices attached to a channel have a compatible pinout on both sides, the SNC 5100 can test the cable using the loop back test.

- Step 1.** Stop all I/O to the SNC 5100.
- Step 2.** If the SNC 5100's command prompt on the terminal is not `diagmode >` place the SNC 5100 in diagnostic mode
- For more information, see "Entering Diagnostic Mode" on page 187.
- Step 3.** Shut down the SNC 5100.
- Step 4.** Remove the cable from one attached SCSI device, and attach it as a loop back cable to the SNC 5100.
- Step 5.** Power on the SNC 5100.
- Step 6.** After the SNC 5100 has finished booting, enter the `scsiChannelTest(x,y)` command from the service terminal (where 'x' and 'y' are the slot numbers connected by the loopback cable) to perform a loop back test.
- For an example, see "SCSI Loop Back Test" on page 58, Step 8.
- Step 7.** If the SNC 5100 returns a FAILED status, the cable is faulty and must be replaced.
- If the SNC 5100 returns a PASSED status, go to **"Isolating SCSI devices"** to isolate bad devices on the SCSI bus.

Isolating SCSI devices

- Step 1.** Restore the SNC 5100 to normal operation.
- See "Restoring Normal Mode" on page 188.
- Step 2.** Power down the SNC 5100.
- Step 3.** Perform Steps 4 - 11 for each SCSI device that was found missing in Step 1 under "Compare Listed versus Physical Devices" on page 52.

-
-
- Step 4.** Remove all devices from the SCSI buses.
- Step 5.** Attach **ONLY** the device in question to the SCSI channel it was originally connected to using a known-good SCSI cable and terminators.
- Step 6.** Power the SNC 5100 back on. Wait for it to finish booting.
- Step 7.** Enter the `scsiShow` command from the service terminal and verify the device's presence.
- For more information, see the "`scsiShow`" command on page 160.
- Step 8.** If the device is missing from the display, it needs to be replaced and/or serviced.
- Inform the system administrator of any suspected bad devices found in this step.
- Replace or remove any bad devices.
- Step 9.** If the device is present, perform a health check.
- For more information, see "Perform Health Check" on page 46.
- Step 10.** Review the host event log.
- For more information, see "Check the Host Event Log" on page 47.
- Step 11.** If SCSI errors are found, then inform the system administrator that the connected device appears to be bad.
- Replace or remove any bad devices.
- Step 12.** After all possible device checks are performed go to "**Restore SCSI Setup**".

Restore SCSI Setup

- Step 1.** Shut down the SNC 5100.
- Step 2.** Reconnect all available SCSI devices to their proper channel assignments.
- Use the original configuration, except where changes have been made per this MAP.

- Step 3.** Wait for the SNC 5100 to finish booting.
- Step 4.** If the SNC 5100 is in diagnostic mode (command prompt = `diagmode >`), then restore normal operation.
- For more information, see “Restoring Normal Mode” on page 188.
- Step 5.** Perform a health check.
- For more information, see “Perform Health Check” on page 46.
- Step 6.** Review the host event log.
- For more information, see “Check the Host Event Log” on page 47.
- If all attached SCSI devices and cables are determined to be good, yet SCSI errors persist, replace the SNC 5100.
- Go to “Before Removing or Replacing the Unit” on page 82.
- Proceed through “Replacing the SNC 5100” on page 84.
- Exit this MAP.

Fibre Channel MAP

Perform these steps if:

- The Fibre Channel interface reports a reset or system error
- The Fibre Channel interface reports an error processing a request or response
- The Fibre Channel interface reports an excess of 10 LIPs in a 10-minute interval
- Other Fibre Channel errors reported
- FC connection LED is off

Verify Fibre Channel Connections

- Step 1.** Connect the service terminal to the Service Port.
- For more information, see “Connecting to the Service Port” on page 95.

- Step 2.** Press the **Enter** key on the service terminal.
- If the prompt is not displayed, go to “Service Port MAP” on page 75.
- Step 3.** From the service terminal, enter the `showBox` command.
- For more information, see the "`showBox`" command on page 170.
- Step 4.** Confirm that the Fibre Channel connections are correctly displayed. If `showBox` displays the Fibre Channel connections correctly, go to "**Examine Cables**".
- Step 5.** If the Fibre Channel connections do not display correctly in the `showBox` display, remove the GBIC and replace it with a known-good GBIC.
- Go to “Removing the GBIC” on page 82.
- Proceed through “Replacing the GBIC” on page 82.
- Step 6.** Proceed to "**Test GBIC**".

Test GBIC

Caution

You must stop I/O at the Fibre Channel host.

- Step 1.** With a known-good GBIC installed, confirm that the SNC 5100’s Fibre Channel connections are correctly displayed by issuing the `showBox` command from the service terminal.
- For more information, see the "`showBox`" command on page 170.
- Step 2.** If the output of the `showBox` command matches the Fibre Channel configuration, exit this MAP.
- If the output of the `showBox` command, still does not match the Fibre Channel configuration, remove the known-good GBIC and reinstall the original GBIC.
- Go to "**Examine Cables**".

Examine Cables

Caution

If in this procedure, you need to remove or replace the Fibre Channel cable, you must stop I/O at the Fibre Channel host.

- Step 1.** Remove the cables.
- Step 2.** If any cables are obviously damaged, replace them.
- Step 3.** Use dusting spray/compressed gas to dust off optical connectors on the GBIC and cable ends.
- Step 4.** Reconnect the cables.
- Step 5.** Perform Health Check.
- For more information, see “Perform Health Check” on page 46.
- Step 6.** View the event log at viewing level 3.
- For more information, see Table 9, “Event Viewing Levels,” on page 42.
- Step 7.** If errors are gone, exit this MAP.
- If errors persist, go to **"Fibre Channel Loop Back Test"**.

Fibre Channel Loop Back Test

Caution

Before performing diagnostics, the Fibre Channel cables must be removed from the SNC 5100. All I/O to the SNC 5100 must be stopped.

- Step 1.** Attach a Fibre Channel loop back plug to the Fibre Channel port.
- Step 2.** If the front-panel FC Connection Status LED is not on, replace the SNC 5100.
- For more information, see Figure 4 on page 14.
- Go to “Before Removing or Replacing the Unit” on page 82.
- Continue through “Replacing the SNC 5100” on page 84.

Exit this MAP.

If the front-panel FC Connection Status LED is on, proceed to Step 3.

- Step 3.** If the SNC 5100's command prompt on the service terminal is not `diagmode >`, place the SNC 5100 in diagnostic mode.

For more information, see "Entering Diagnostic Mode" on page 187.

- Step 4.** Substituting the Fibre Channel slot number for `x`, enter the `fcSlotTest x` command.

For more information, see "`fcSlotTest [x]`" command on page 192.

- Step 5.** If the test failed, replace the SNC 5100.

Go to "Before Removing or Replacing the Unit" on page 82.

Continue through "Replacing the SNC 5100" on page 84.

Exit this MAP.

If the test passed, the Fibre Channel port is good.

- Step 6.** Remove the loop back plug.

Go to "[Testing Fibre Channel Optical Cable](#)".

Testing Fibre Channel Optical Cable

Caution

If the Fibre Channel cable is extremely long it may be more practical to replace the Fibre Channel device first; then if the problem is not resolved, replace the cable.

- Step 1.** If the cables are already removed, reattach them.

Attach matching cable ends (red-to-red or 'A'-to-'A' and so on) to both slots of the Fibre Channel port.

- Step 2.** Substituting the Fibre Channel slot number for `x`, from the service terminal enter the `fcSlotTest x` command.

For more information, see "fcSlotTest [x]" command on page 192.

Step 3. If the test passes, the Fibre Channel optical cable is good.

Go to "[Replace Fibre Channel Device](#)".

If the test fails, go to "[Replace Fibre Channel Cable](#)".

Replace Fibre Channel Cable

Step 1. Replace the cables to the Fibre Channel ports with known good cables.

Step 2. Perform Health Check.

For more information, see "Perform Health Check" on page 46.

Step 3. View the event log at viewing level 3.

For more information, see Table 9, "Event Viewing Levels," on page 42.

Step 4. If problems persist, inform the network administrator that there seems to be a problem with a device or a host bus adapter.

If problems are gone, exit this MAP.

Step 5. Replace external devices that are attached to the Fibre Channel ports.

Go to "[Replace Fibre Channel Device](#)".

Replace Fibre Channel Device

The device that needs to be replaced is one of the following:

- Fibre Channel HBA
- Fibre Channel Switch
- Fibre Channel Hub

- Step 1.** Inform the system administrator that it is necessary to replace the Fibre Channel device connected to the SNC 5100 to resolve the Fibre Channel errors.
- Step 2.** Repeat this MAP, beginning with the section “Verify Fibre Channel Connections” on page 61, after replacing the external component.

MAP for the SNC 5100

Perform these steps if:

- **RDY** LED not blinking once per second after power has been on for one minute
- The SNC 5100 is not responding
- SNC 5100 processor memory fault detected
- SNC 5100 PCI bus parity error detected
- SNC 5100 PCI interface error detected
- The ADIC Management Console Server could not verify the connection to the SNC 5100

Observe Operational LED Behavior

When the SNC 5100 is first powered on, the front-panel’s LEDs flash a variety of patterns as it performs the Power On Self Test (POST) and then starts booting.

For more information, see “POST Error Codes” on page 197.

Within one minute, the SNC 5100 should have booted successfully and the **Ready** LED should be blinking once per second.

If the **Ready** LED is not blinking as expected, go to “Start MAP” on page 42.

Temperature MAP

Perform these steps if:

- The SNC 5100 generates Trap Event Codes 62, 64, or 67 (Inlet Air, Outlet Air, I/O Processor, or Fan have entered a Warning Range)

- The SNC 5100 generates Trap Event Codes 63, 65, or 68 (Inlet Air, Outlet Air, I/O Processor, or Fan have entered Alarm Range)
- Health Check generates Trap Event Code 112 or 114 (Fan or Power are running in Warning or Alarm Range)

Notification of Problems in Temperature Subsystem

System operators are normally notified of problems or potential problems in SNC 5100 subsystems by the event traps that appear in the “Received Event Trap” window of the ADIC Management Console client.

For more information, see the *ADIC Management Console User Guide*.

However, when sensors detect a Warning or Alarm condition in the Temperature subsystem, not only are Trap Event Codes 62, 63, 64, or 65 generated, but a pop-up dialog box immediately alerts the user.

See the "envMonShow" command on page 118 for operational temperature ranges that will generate these messages.

If the temperature problems are due to a reduction in blower functionality, Event Codes 62, 63, 64, or 65 will be accompanied by Event Codes 67 or 68.

See the "envMonRangeShow" command on page 119 for conditions that will generate these messages.

Temperature Warnings or Alarms Received

- Step 1.** Verify that room temperature is within satisfactory limits.
- Step 2.** If room temperature is not within satisfactory limits, adjust it.
- Step 3.** If the room temperature is within satisfactory limits, and alarm or warning messages are being generated, check the air intake for obstructions.

Caution

The Inlet Air sensor is at the end with the plastic bezel and the on/off switch. The Outlet Air sensor is the end with the connectors.

- Step 4.** If obstructions are found, remove them and permit the SNC 5100 to cool.
- Step 5.** If temperatures stabilize, exit this MAP.
- Step 6.** If no obstructions are found, or temperatures do not stabilize, check the SNC 5100's Air Outlet for obstructions.
- Step 7.** If obstructions are found, remove them and permit the SNC 5100 to cool.
- Step 8.** If temperatures stabilize, exit this MAP.
- Step 9.** If no obstructions are found, or temperatures do not stabilize, replace the unit.

Proceed to "Before Removing or Replacing the Unit" on page 82.

Continue through "Replacing the SNC 5100" on page 84.

Fan Speed is in Warning or Alarm Range

If you were directed to this MAP because of Trap Event Code 67, indicating that the Fan is in Warning Range--replace the SNC 5100 at the next scheduled maintenance.

If you were directed to this MAP because of Trap Event Code 68, indicating that the Fan is in Alarm Range, Proceed to "Before Removing or Replacing the Unit" on page 82.

Continue through "Replacing the SNC 5100" on page 84.

Power MAP

Perform these steps if:

- All LEDs are off
- The SNC 5100 generates Trap Event Codes 59 or 60, indicating that the Power is running in the Warning or Alarm Range. A string accompanying a Trap Event will indicate which power supply is specifically involved.
- Health Check generates a Trap Event Code 113, indicating that Power is running in Warning or Alarm Range

- Step 1.** Verify that the SNC 5100 is plugged into an active AC power source.
- Step 2.** Verify the status of the SNC 5100 Power LED.
For more information, go to Figure 4 on page 14.
- Step 3.** If the Power LED remains off, try a different power cord.
- Step 4.** If the Power LED remains off, remove the SNC 5100.
Proceed to “Before Removing or Replacing the Unit” on page 82.
Continue through “Replacing the SNC 5100” on page 84.

Ethernet MAP

The network administrator must provide the following information before you can perform this MAP:

- The IP address for the SNC 5100 - REQUIRED
- The net mask for the SNC 5100 in decimal and hex formats - REQUIRED
- The network gateway IP address for the SNC 5100 - if assigned
- The IP address of a computer on the same subnet as the SNC 5100 for PING tests - REQUIRED
- The IP address of the ADIC Management Console Server - REQUIRED.
For more information, see the *ADIC Management Console User Guide*.

- Step 1.** The SNC 5100 must be booted and its Ethernet Port must be attached to the local area network.

For the position of the Ethernet port on the SNC 5100, see Figure 7.

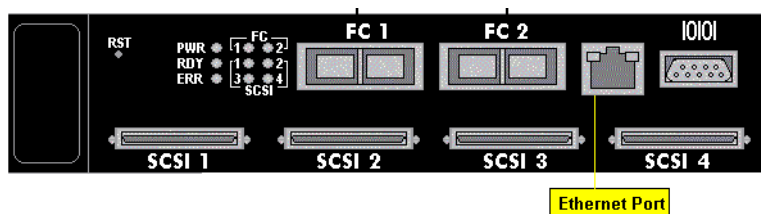

Figure 7: Ethernet Port on Faceplate

Step 2. Verify that the Ethernet Link LED, which is the green LED on the left, is on.

Step 3. If the LED is on, go to step 4.

If the LED is not on, proceed to “Before Removing or Replacing the Unit” on page 82.

Continue through “Replacing the SNC 5100” on page 84.

Exit this MAP.

Step 4. Determine the speed of the network, by following the procedure in “Perform Health Check” on page 46.

If the Health Check generates a Trap Event Code of 115, then the SNC 5100’s yellow Speed LED should be on.

Verify that the yellow Speed LED, which is the yellow LED on the right, correctly reflects the speed of the network.

Step 5. If the yellow Speed LED correctly reflects the speed of the network, go to Step 7.

If the yellow Speed LED does not correctly reflect the speed of the network, go to Step 6.

Step 6. Inform the System Administrator that there may be a problem with the Ethernet cable quality, the intermediate link speeds or interconnect speeds.

If the System Administrator can find no problems with the Ethernet cable quality, the intermediate link speeds, or interconnect speeds, but the SNC 5100 yellow Speed LED does correctly reflect the network speed, go to “Before Removing or Replacing the Unit” on page 82.

Continue through “Replacing the SNC 5100” on page 84.

Exit this MAP.

Step 7. Remove the Ethernet cable from the SNC 5100 Ethernet Port and attach the Ethernet loop back plug.

Step 8. Verify that the Ethernet LEDs are functioning correctly.

If they are, proceed to Step 9.

If they are not, inform the system administrator that there is a network hardware problem where the SNC 5100 is attached.

Exit this MAP.

- Step 9.** Remove the Ethernet loop back plug.
- Step 10.** Obtain another Ethernet cable.
- Step 11.** Use this cable to attach the SNC 5100 to the local area network.
- Step 12.** Connect the service terminal to the Service Port.

For more information, see “Connecting to the Service Port” on page 95.

- Step 13.** Press the **Enter** key on the service terminal.

If the prompt is not displayed, go to “Service Port MAP” on page 75.

- Step 14.** From the service terminal, enter the `ifShow` command.

For more information, see the "`ifShow`" command on page 139.

Example:

```
SN60023 > ifShow
ibmEmac (unit number 0):
  Flags: (0x8063) UP BROADCAST MULTICAST ARP RUNNING
  Type: ETHERNET_CSMACD
  Internet address: 172.16.76.211
  Broadcast address: 172.16.255.255
  Netmask 0xffff0000 Subnetmask 0xffff0000
  Ethernet address is 00:60:45:17:02:f0
  Metric is 0
  Maximum Transfer Unit size is 1500
  114192 packets received; 364 packets sent
  114023 multicast packets received
  116 multicast packets sent
  0 input errors; 0 output errors
  0 collisions; 0 dropped
```

```
lo (unit number 0):
  Flags: (0x8069) UP LOOPBACK MULTICAST ARP RUNNING
  Type: SOFTWARE_LOOPBACK
  Internet address: 127.0.0.1
  Netmask 0xff000000 Subnetmask 0xff000000
  Metric is 0
  Maximum Transfer Unit size is 32768
  0 packets received; 0 packets sent
  0 multicast packets received
  0 multicast packets sent
  0 input errors; 0 output errors
  0 collisions; 0 dropped
  value = 29 = 0x1d
```

Step 15. If there is no entry for `ibmEmac`, replace the SNC 5100.

Go to “Before Removing or Replacing the Unit” on page 82.

Continue through “Replacing the SNC 5100” on page 84.

Exit this MAP.

If there is an entry for `ibmEmac`, write down the values of the:

- internet address,
- netmask,
- subnetmask

Step 16. Verify that the internet address is the same as the IP address supplied by the network administrator.

Step 17. Verify that the netmask value is the same as the netmask in hex format supplied by the network administrator.

Step 18. Verify that the subnetmask is the same as the netmask. If these values are correct, go to step 21.

If these values are not correct, proceed to Step 19.

Step 19. Use the `ethAddrSet` command to set the correct IP address and netmask values.

For more information, see the "`ethAddrSet`" command on page 121.

Step 20. From the service terminal, enter the `reboot` command and wait for the SNC 5100 to finish booting.

Go back to step 14.

Step 21. Enter the command `ping "<host IP address>"`, where `<host IP address>` is four decimal numbers separated by periods.

`<host IP address>` is the address provided by the network administrator for PING testing.

Display of successful PING test:

Example:

```
SN60023 > ping "192.168.1.1", 10
PING 192.168.1.1: 56 data bytes
64 bytes from 192.168.1.1: icmp_seq=0. time=0. ms
64 bytes from 192.168.1.1: icmp_seq=0. time=0. ms
64 bytes from 192.168.1.1: icmp_seq=0. time=0. ms
64 bytes from 192.168.1.1: icmp_seq=0. time=0. ms
64 bytes from 192.168.1.1: icmp_seq=0. time=0. ms
64 bytes from 192.168.1.1: icmp_seq=0. time=0. ms
64 bytes from 192.168.1.1: icmp_seq=0. time=0. ms
64 bytes from 192.168.1.1: icmp_seq=0. time=0. ms
64 bytes from 192.168.1.1: icmp_seq=0. time=0. ms
64 bytes from 192.168.1.1: icmp_seq=0. time=0. ms
64 bytes from 192.168.1.1: icmp_seq=0. time=0. ms
----192.168.1.1 PING Statistics----
10 packets transmitted, 10 packets received, 0% packet loss
round-trip (ms) min/avg/max = 0/0/0
value = 0 = 0x0
```

Display of failed PING test:

Example:

```
SN60023 > ping "192.168.1.251",10
PING 192.168.1.251: 56 data bytes
request timed out
value = -1 = 0xffffffff
```

Step 22. If the PING test passes, go to step 23.

If the PING test fails, inform the system administrator that there is a network hardware problem where the SNC 5100 is attached.

Exit this MAP.

Step 23. Remove the Ethernet cable from the SNC 5100 and install the Ethernet loop back plug.

Step 24. From the service terminal, enter the `diagBoot` command.

For more information, see “Entering Diagnostic Mode” on page 187.

Step 25. Wait for the SNC 5100 to finish booting.

Step 26. Verify that the `diagmode>` prompt is displayed.

Step 27. From the service port, enter the `elTest` command.

Example:

```
diagmode > elTest
==== Testing Ethernet ====
Init complete.
Ethernet OK
value = 0 = 0x0
```

Step 28. If the test fails, replace the SNC 5100.

Go to “Before Removing or Replacing the Unit” on page 82.

Continue through “Replacing the SNC 5100” on page 84.

Exit this MAP.

If the test passes, remove the Ethernet loop back plug.

Proceed to Step 29.

Step 29. From the service terminal, enter the `normalBoot` command and wait for the SNC 5100 to finish booting.

Step 30. Reattach the Ethernet cable to the SNC 5100.

Step 31. From the service terminal, enter the `gateAddrGet` command and write down the network gateway address that is displayed.

For more information, see the “`gateAddrGet`” command on page 131.

Step 32. Compare this address to the one provided by the network administrator.

If both addresses are the same, go to step 33.

Example:

```
SN60023 > gateAddrGet
Gateway Address set to 192.168.1.1
value = 0 = 0x0
```

If the network gateway address is incorrect, set it to the value provided by the network administrator using the `gateAddrSet` command.

For more information, see the "`gateAddrSet`" command on page 131.

Step 33. From the service terminal, enter the `reboot` command.

Step 34. Wait until the SNC 5100 has finished booting.

Step 35. From the service terminal, use the `ping` command to PING the IP address of the ADIC Management Console Server.

For more information, see the *ADIC Management Console User Guide*.

Step 36. From the host running the ADIC Management Console Server, PING the SNC 5100.

If both PING tests succeed, exit this MAP.

If a PING test fails, inform the network administrator to check and correct the network connection, route tables, and network gateway addresses for both the ADIC Management Console Server and the SNC 5100.

Service Port MAP

These steps are performed if the SNC 5100 boots and responds to the ADIC Management Console, but the Service Port does not respond.

For more information, see the *ADIC Management Console User Guide*.

Check the RS-232 Cable

This test requires another laptop or desktop computer with a functioning RS-232 9-pin port. Terminal emulation software must be installed and running.

- Step 1.** Remove the RS-232 null-modem cable from the service port.
- Step 2.** Connect it to the compatible port on the other computer.
- Step 3.** Connect the service terminal to the cable.
- Step 4.** Set the service terminal and the other computer to 19200 baud, 8 data bits, no parity, one stop, Xon/Xoff flow control.
- Step 5.** Enter test lines in the service terminal and the other computer.
- Step 6.** Confirm that they are displayed on each other.

If this fails, replace the RS-232 cable.

If this succeeds, remove the cable from the other computer

Go to "[Check Connection with Boot Messages](#)".

Check Connection with Boot Messages

- Step 1.** Reconnect the terminal to the SNC 5100 with the RS-232 null modem cable.
- Step 2.** Stop all I/O to the SNC 5100.
- Step 3.** Shut down the SNC 5100 and keep the power off for 5 seconds.
- Step 4.** Turn the SNC 5100 on.

If boot messages fail to appear on the service terminal, then replace the SNC 5100.

Go to “Before Removing or Replacing the Unit” on page 82.

Proceed through “Replacing the SNC 5100” on page 84.

- Step 5.** Reboot the SCSI host.

If devices are still unavailable, proceed to "[SCSI Channel MAP](#)".

Virtual Private SAN®Scalar Firewall Manager Settings MAP

Perform these steps if SFM devices are unavailable.

Check Scalar Firewall Manager Access Settings

Step 1. Connect the service terminal to the Service Port.

For more information, see “Connecting to the Service Port” on page 95.

Step 2. Press the **Enter** key on the service terminal.

If the prompt is not displayed, go to “Service Port MAP” on page 75.

Step 3. Enter the `sfmShow -1` command from the service terminal.

For more information, see the "`sfmShow [hostIndex]`" command on page 168

Step 4. If **SFM State: Inactive** is displayed, Scalar Firewall Manager is not controlling access between the host and target devices. Proceed to Step 5.

If **SFM State: Active** is displayed, Scalar Firewall Manager® is controlling access between the host and the target devices. Proceed to Step 8.

Step 5. Enter the `sfmFeatureEnable` command from the service terminal.

For more information, see the or the "`sfmFeatureEnable "license key string"`" command on page 166.

If SFM devices are available, exit this MAP.

If SFM devices are not available, proceed to Step 6.

Step 6. Enter the `licenseShow` command from the service terminal.

For more information, see the "licenseShow" command on page 141.

Example:

```
License "s2zhq-7xdhd": Valid
  Features:
    SFM
Value = 2 = 0 x 2
```

Step 7. If the output from the `licenseShow` command shows that SFM is Valid, as in the example, proceed to Step 8.

If the output from the `licenseShow` command shows that SFM is not Valid, exit this MAP and contact your service representative.

Step 8. Use the ADIC Management Console to verify the host and target device access settings.

For more information, see the *ADIC Management Console User Guide*.

Exit this MAP.

If the ADIC Management Console is not available, you can temporarily make SFM inactive to verify that the host can access all devices. Proceed to "[Verify Host Access to Devices](#)".

Verify Host Access to Devices

Step 1. Shut down all of the hosts.

Step 2. Enter the `sfmInactive Set` command from the service terminal.

For more information, see the "`sfmInactiveSet`" command on page 167.

Step 3. Startup one of the hosts.

Step 4. If the host can access all of the target devices, shut down the host and repeat steps 2 and 3 for each of the other hosts.

If each host can access all devices then there is a problem with the Scalar Firewall Manager Access settings. Go to step 5.

If the host cannot access all of the target devices, then there is a problem with the devices or their SAN connections. Proceed to “Device Access MAP” on page 48 or “Fibre Channel MAP” on page 61.

Step 5. Shut down all of the hosts.

Step 6. Enter the `sfmActiveSet` command from the service terminal.

For more information, see the "`sfmActiveSet`" command on page 165.

Step 7. Use the ADIC Management Console to verify the host and target device access settings.

For more information, see the *ADIC Management Console User Guide*.

Removal and Replacement Procedures

This section describes the removal and replacement procedures for the SNC 5100 in its entirety or for one or more of its GBICs.

Handling Electrostatic Discharge-Sensitive Parts

Caution

It is highly recommended that you follow industry best practice when handling Electrostatic Discharge (ESD) Sensitive Parts.

- Keep the ESD-sensitive part in a static-protective bag until you are ready to install the part into the machine.
- Make the fewest possible movements with your body to prevent an increase of static electricity from clothing, fibers, carpets, and furniture.
- If instructed to do so, switch off the machine power before you remove ESD-sensitive parts.
- Just before touching the ESD-sensitive part, discharge to the machine any static electricity in your body by touching the metal frame or cover of the machine. If possible, keep one hand on the frame when you install or remove an ESD-sensitive part.
- You may opt to wear an ESD wrist strap.
- Do not place any ESD-sensitive parts on the machine cover or on a metal table because large metal objects can become discharge paths if they are not grounded. If you must set aside an ESD-sensitive part, first place it into the ESD static-protective bag.
- Prevent ESD-sensitive parts from being accidentally touched by other personnel.
- If possible, keep all ESD-sensitive parts in a grounded metal case.
- Be very careful when you work with ESD-sensitive parts in cold weather. Low humidity and heating increase static electricity.

Removing and Replacing the GBIC

Caution

Shut down the host systems to ensure that all I/O through the SNC 5100 has stopped.

Removing the GBIC

Caution

You must stop I/O at the Fibre Channel host.

- Step 1.** Review “Handling Electrostatic Discharge-Sensitive Parts” on page 81.
- Step 2.** Unplug the Fibre Channel cable.
- Step 3.** Slide the GBIC out of the slot.
- Step 4.** Place the GBIC in a static-protective bag.

Replacing the GBIC

Caution

You must stop I/O at the Fibre Channel host.

- Step 1.** Review “Handling Electrostatic Discharge-Sensitive Parts” on page 81.
- Step 2.** Insert the known good GBIC into the slot.
- Step 3.** Remove the dust caps from a known good GBIC.
- Step 4.** Plug the Fibre Channel cables back in, being sure to use the correct polarity.
- Step 5.** If you were sent here by another MAP, return to it.

Before Removing or Replacing the Unit

These steps are performed if a repair action is required for any component of the SNC 5100, except for a GBIC.

Caution

Shut down the host systems to ensure that all I/O through the SNC 5100 has stopped.

Step 1. Verify that the latest configuration has been saved.

For more information on saving the configuration, see the *ADIC Management Console User Guide*.

Step 2. Shut the SNC 5100 down and disconnect the power cord.

Step 3. For each cable attached to the SNC 5100, repeat the following:

- Remove the cable.
- Mark what the cable was connected to (for example, SNC 5100 number 3, SCSI channel 1).
- If the final cable has been removed, then return to the MAP that sent you here, or continue with "Removing and Replacing the Unit".

Removing and Replacing the Unit

Caution

Follow all ESD-sensitive parts procedures while performing this procedure. For ESD information, see "Handling Electrostatic Discharge-Sensitive Parts" on page 81.

This procedure describes how to remove and replace the SNC 5100.

Removing the SNC 5100

Step 1. Complete all steps in "Before Removing or Replacing the Unit" on page 82.

Step 2. After the final cable has been removed, pop off the plastic rack-mount bezel, if installed on your unit. Pull it straight out to detach it.

Step 3. Unscrew the four 4-40 x 3/8" screws that hold the units to the rack bracket.

Step 4. Remove the rack bracket from across the width of the 19" rack by unscrewing the two 10-32 x 5/8" screws.

Step 5. Slide the unit out of the rack.

Replacing the SNC 5100

Step 1. Remove the SNC 5100 from the protective bag.

Install the new SNC 5100 in the rack.

Step 2. Plug the power cable in.

Step 3. Complete the "Final Diagnostic Tests".

Final Diagnostic Tests

After the unit has been replaced, a complete diagnostic check must be performed to ensure that no new problems have been introduced.

For further information about the procedures and commands used in this section, see "Connecting to the Service Port" on page 95 and "Diagnostic Command Reference" on page 187.

Final Test Preparation

Step 1. Connect a service terminal to the SNC 5100.

For information about how to do this, see "Connecting to the Service Port" on page 95.

Step 2. Reattach the power cord to the SNC 5100.

Step 3. Turn on the SNC 5100 and wait until it finishes booting.

Step 4. Press the **Enter** key on the service terminal.

If the prompt is not displayed, go to "Service Port MAP" on page 75.

Step 5. From the Service Terminal, enter the `diagBoot` command.

Step 6. Wait until the SNC 5100 has finished booting into diagnostic mode.

- Step 7.** From the Service Terminal, enter the `showBox` command.
- For more information, see the "`showBox`" command on page 194.
- Step 8.** Verify that the SNC 5100 accurately displays the channel information.
- If the `showBox` display is accurate, go to step 9.
- If not, go to "Start MAP" on page 42.
- Step 9.** Proceed to "**Fibre Channel Tests**"

Fibre Channel Tests

For further information about the procedures and commands used in this section, see "Connecting to the Service Port" on page 95 and "Diagnostic Command Reference" on page 187.

Test Fibre Channel Port 1

- Step 1.** Attach the Fibre Channel loop back plug to the GBIC in FC 1.
- Step 2.** From the service terminal, enter the `fcSlotTest 1` command.
- For more information, see the "`fcSlotTest [x]`" command on page 192.
- Step 3.** If the test passes, remove the loop back plug and go to "**Test Fibre Channel Port 2**".
- If the test does not pass, go to "Start MAP" on page 42.

Test Fibre Channel Port 2

- Step 1.** Attach the Fibre Channel loop back plug to the GBIC in FC 2.
- Step 2.** From the service terminal, enter the `fcSlotTest 2` command.
- For more information, see the "`fcSlotTest [x]`" command on page 192.

Step 3. If the test passes, remove the loop back plug and go to "**Test SCSI Port 1 and 2**".

If the test does not pass, go to "Start MAP" on page 42.

Test SCSI Port 1 and 2

Step 1. Attach the appropriate VHDCI cable between SCSI 1 and 2.

Step 2. From the service terminal, enter the `scsiChannelTest 1,2` command.

For more information, see the "`scsiChannelTest (x,y)`" command on page 193.

Step 3. If the test passes, remove the loop back cable and go to "**Test SCSI Port 1 and 2**".

If the test does not pass, go to "Start MAP" on page 42.

Test SCSI Port 3 and 4

Step 1. Attach the appropriate VHDCI loop back cable between SCSI 3 and SCSI 4.

Step 2. From the service terminal, enter the `scsiChannelTest 3,4` command.

For more information, see the "`scsiChannelTest (x,y)`" command on page 193.

Step 3. If the test passes, remove the loop back cable and go to "**Ethernet Test**".

If the test does not pass, go to "Start MAP" on page 42.

Ethernet Test

For further information about the procedures and commands used in this section, see "Connecting to the Service Port" on page 95 and "Diagnostic Command Reference" on page 187.

- Step 1.** If you did not replace the SNC 5100, go to Step 3.
- Step 2.** Obtain the SNC 5100's Ethernet network parameters.
Configure the Ethernet Port Host Name, Address, Routes, Enable Ethernet.
For more information, see "[Network Setup for the SNC 5100](#)".
- Step 3.** Attach the Ethernet loop back plug to the Ethernet port.
- Step 4.** From the service terminal, enter the `e1Test` command.
For more information, see the "`e1Test`" command on page 192.
- Step 5.** If the test passes, go to Step 6.
If the test does not pass, go to See "Start MAP" on page 42.
- Step 6.** Remove the Ethernet loop back plug.
- Step 7.** Proceed to "[Updating the SNC 5100](#)".

Network Setup for the SNC 5100

The SNC 5100 must be connected to a 10/100-base-T Ethernet network for use with the ADIC Management Console software.

For more information, see the *ADIC Management Console User Guide*.

An RJ-45 connector is located on the rear panel of the SNC 5100 for connection to the Ethernet. See Figure 8.

You will need to connect a terminal or terminal emulator to the Service Port of the SNC 5100 in order to configure the IP address.

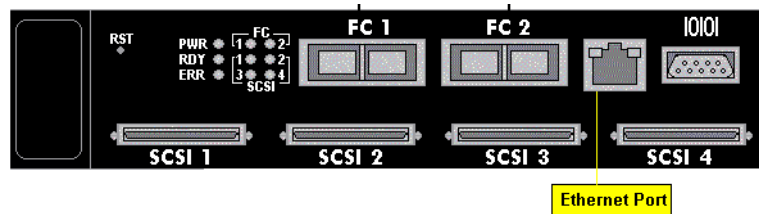

Figure 8 Ethernet Port

Step 1. To configure the network, connect to the SNC 5100 Service Port.

For more information, see “Connecting to the Service Port” on page 95.

In all of the subsequent steps, substitute the values you determined in Step 6 of Table 2, “Pre-Installation Checklist,” on page 19.

Step 2. Enter the `hostNameSet` command to set the Host name.

For more information, see the "`hostNameSet`" command on page 138.

In the example shown, the host name of the SNC 5100 was “SN60023” and is now being set to “foster.” The shell prompt will change to reflect the new name.

Example:

```
SN60023 > hostNameSet "foster"
Target hostname set to foster
value = 0 = 0x0
foster >
```

Step 3. Use the `ethAddrSet` command to set the host network address:

For more information, see the "`ethAddrSet`" command on page 121.

The IP address is specified as four decimal numbers, separated by periods.

Example:

```
foster > ethAddrSet "192.168.1.54"
Host Address set to 192.168.1.54 for Ethernet interface
value = 0 = 0x0
```

If you need to set a netmask, specify it after the network address:

Example:

```
foster > ethAddrSet "10.0.0.2", "255.0.0.0"
```

If you need a network route and/or default gateway, you must specify it.

Example:

```
foster > gateAddrSet "192.168.1.1"  
value = 0 = 0x0
```

When more complicated routing is required, use the `route` command to specify the destination address, as a full address (single host) or as an abbreviated subnet address.

Specify the address of the gateway that is reachable on the local subnet.

Example:

```
foster > route "add", "206.0.0", "192.168.1.1"  
value = 0 = 0x0
```

Step 4. Optionally, add User account for Telnet

If you want to access the SNC 5100's command line interface through its Ethernet port using a Telnet session, you need to add a user account.

The user name you specify must be 3 or more characters. The password you specify must be 8 or more characters.

For more information, see the commands beginning with `user` in the "Service Port Command Reference" on page 105.

Example:

```
foster > userAdd "username", "password"  
value = 0 = 0x0  
foster >
```

Step 5. Enter the `reboot` command to reboot the SNC 5100:

For more information, see the "`ethAddrSet`" command on page 121.

Example:

```
foster > reboot
```

Updating the SNC 5100

- Step 1.** From the service terminal, enter the `normalBoot` command.
- For more information, see the "`normalBoot`" command on page 191.
- Step 2.** Wait until the SNC 5100 has finished booting.
- Step 3.** From the service terminal, enter the `version` command.
- For more information, see the "`version`" command on page 185.
- Step 4.** Write down the operating software version number.
- Step 5.** Determine whether the SNC 5100's firmware version requires an update.
- If an update is required, download the new file or files and the associated readme.
- You will install the new firmware as you complete the "**Post-Repair Checklist**".
- Step 6.** If you replaced the SNC 5100, enter the `ridTag` command and type the identifier.

Caution

You must perform this step if you replaced the SNC 5100.

For more information, see the "`ridtag [\"value\"]`" command on page 152.

- Step 7.** Shut down the SNC 5100.
- Step 8.** Unplug the power cord.
- Step 9.** Disconnect the RS-232 cable from the SNC 5100.
- Step 10.** Proceed to "**Post-Repair Checklist**".

Post-Repair Checklist

It is important that the items in this checklist are verified after you have completed a repair action. This ensures a successful reinstall of the product.

Table 4-1: Post-Repair Checklist

Step	Actions	Comments and References
1	Reinstall the SNC 5100 in its original location.	See “Replacing the SNC 5100” on page 84
2	Ensure that the FC hosts are turned off. If not, disconnect the FC cables now.	If you cannot turn off the FC hosts you must disconnect the FC hosts before turning on the SNC 5100. This is a safety precaution that ensures that FC hosts cannot perform any I/O to the SCSI target devices prior to restoring the SNC 5100 configuration in step 8, below.
3	Attach the Service Terminal to the SNC 5100	None.
4	Turn on the SNC 5100.	None.
5	Wait for the SNC 5100 to finish booting.	Within one minute, the Ready LED should start flashing once per second and the “Done executing startup script” message should be displayed on the service terminal. If not, go to “Start MAP” on page 42.
6	From the service terminal, enter the <code>targets</code> command.	See “Service Port Command Reference” on page 105. If all attached SCSI devices are not shown, go to “Start MAP” on page 42.
7	If you replaced the SNC 5100, configure the network parameters.	Obtain the network parameters.

Table 4-1: Post-Repair Checklist

Step	Actions	Comments and References
8	Perform the following: <ul style="list-style-type: none"> • Start the ADIC Management Console Server and Client. • Log on with administrator privileges. • Connect to the SNC 5100. • If you downloaded new operating software in Step 5 of “Updating the SNC 5100” on page 90, update the firmware. • Load the configuration file you saved in Step 1 of “Before Removing or Replacing the Unit” on page 82 into the SNC 5100. • Restart the SNC 5100. 	This step must be performed if you replaced the SNC 5100 For more information, see the <i>ADIC Management Console User Guide</i> .
9	Reconnect the FC cables or, if you turned off the FC hosts, turn them back on.	If FC1 and/or FC2 Connection Status LEDs for the attached hosts are not on, check the FC cables. You may have to change the polarity of the FC cables. If the problem persists, go to “Start MAP” on page 42.

Table 4-1: Post-Repair Checklist

Step	Actions	Comments and References
10	<p>From the service terminal, enter the <code>fcShow</code> command to show the status of each FC interface that is installed and connected.</p> <p>From the service terminal, enter the <code>fcShowDevs</code> command to show the SCSI target devices that are connected as seen by the Fibre Channel interface.</p>	<p>In the output of the <code>fcShow</code> command, look for the Firmware State column.</p> <p>If the word Ready does not appear, go to “Fibre Channel MAP” on page 61.</p> <p>Check to see that all SCSI target devices are seen by each FC interface.</p> <p>If not, go to “SCSI Channel MAP” on page 50.</p>
11	<p>Verify that all (or the designated) target devices are available to the host systems.</p>	<p>Use appropriate host system utilities for tape. See Table 4, “Host Utility Software,” on page 23.</p> <p>If “Access Control” is enabled (Channel Zoning or SFM) the hosts will only see the devices that have been assigned to them.</p> <p>If the designated devices are NOT available, reboot the host and check again.</p> <p>If the problem persists, go to “Start MAP” on page 42.</p>
12	<p>Disconnect the RS-232 cable from the and from the service terminal.</p>	<p>None.</p>
13	<p>End of repair.</p>	

Connecting to the Service Port

The service port is an RS-232C Data Terminal Equipment (DTE) port, configured at 19200 Baud, with 8 data bits, no parity and either hardware flow control or Xon/Xoff flow control.

The 9-pin connector is compatible with serial ports on PCs. A PC may be used to connect to the service port, using a 9-pin to 9-pin null modem cable.

For connection to another system, such as a UNIX workstation, a different cable or an adapter may be required.

Service Port Connections

The figure below shows the service port connections.

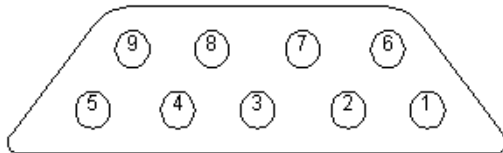

Figure 9 Service Port Pinout

Connections are listed in the following table.

Table 10: DB-9 RS-232 Connector Pin Assignments

Pin Number	Signal Name	Abbreviation	Direction relative to SNC 5100
1	Carrier Detect	CD	In
2	Receive Data	RD	In
3	Transmit Data	TD	Out
4	Data Terminal Ready	DTR	Out
5	Signal Ground	SG	-
6	Data Set Ready	DSR	In
7	Request to Send	RTS	Out
8	Clear to Send	CTS	In
9	Ring Indicator	RI	In

Table 11 lists the null modem cable connections.

Table 11: Null Modem Cable Connections

Service Port Pin Number	Signal Name	9-pin AT connector	25-pin (DB25) connector (DTE)
1	Carrier detect (not used)	n/c	n/c
2	Receive data <-> Transmit data	3	2
3	Transmit data <-> Receive data	2	3
4	Data terminal ready <-> Data set ready	6	6
5	Signal ground	5	7
6	Data set ready <-> Data terminal ready	4	20
7	Request to send <-> Clear to send	8	5
8	Clear to send <-> Request to send	7	4
9	Ring indicator (not used)	n/c	n/c

Connecting the Service Terminal

Hardware Required

- RS-232 DB9F null model cable
- RS-232 DTE Terminal or desktop/laptop computer running terminal emulation software
- RS-232 DB9M-to-DB25F adapter if the terminal uses a DB25M connector

Initial Setup of HyperTerminal

This section shows the steps to setup use the HyperTerminal program. Other terminal emulation programs operate in a similar fashion.

- Step 1.** Connect the null modem cable (and the 9- to 25-pin adapter if applicable) from the computer serial (COM) port to the SNC 5100 Service Port.
- Step 2.** Turn on the service terminal.
- Step 3.** On the service terminal, select the HyperTerminal icon and double-click on it.
- Step 4.** In the New Connection dialog enter **SNC5100** for the name and click OK.
- Step 5.** In the Connect To dialog, for the Connect using field select the COM Port number that you have chosen and click OK.
- Step 6.** In the COM Properties dialog select the following:
- Bits per second:19200
 - Data bits:8
 - Parity:None
 - Stop bits:1
 - Flow Control: Hardware or Xon/Xoff
- Step 7.** Click OK.

Verifying the Connection

If the SNC 5100 is already on, then characters typed in the terminal should be visible to the operator. The simplest test is to press the **Enter** key. The SNC 5100 responds by displaying a command prompt:

Example :
SN60023 >

When the SNC 5100 is rebooting, several messages are displayed on the service terminal. A successful boot is indicated by the last message: "Done executing startup script".

Updating Firmware and Configurations

Although the ADIC Management Console is the simplest and most efficient tool for updating firmware and saving/loading configurations, you can use the service terminal as an alternate method to perform these operations.

For more information, see the *ADIC Management Console User Guide*.

The ADIC Management Console service port supports Zmodem file transfers. The procedures below are specific for using the HyperTerminal program on the service terminal to transfer files. Other terminal emulation programs operate in a similar fashion.

The Zmodem send and receive functions in some terminal emulation programs automatically issue the command string “rz” before sending a file and the command string “sz” before receiving a file. However, even if the program you are using automatically sends the “rz” command, manually issuing the command string “rz” before starting the transfer has no negative effect on the transfer.

Updating SNC 5100 Firmware

- Step 1.** From the Hyper Terminal window, at the `SN60023 >` command prompt, type `rz` and then press the Enter key.
- Step 2.** From the HyperTerminal window select `Transfer` and `Send File`.
- Step 3.** From the `Send File` dialog enter the path and filename where the firmware file is located or click the `Browse` button and navigate to it.
- Step 4.** In the `Protocol` field, select `Zmodem` and click the `Send` button.
- Step 5.** It will take several minutes for the file to be transferred. The Zmodem file send dialog will display the current status and it will close automatically when the file transfer has completed.
- Step 6.** Wait for the *Firmware Update Complete* status message to be displayed on the service terminal indicating successful completion.
- Step 7.** Reboot the SNC 5100 for the update to take effect.

For more information, see the “`reboot`” command on page 151.

If HyperTerminal reports an error, try to send the file again.

If the SNC 5100 reports an error, make a note of the error code and see the Table 12, “Zmodem Status Codes,” on page 100 for further information.

Saving a Configuration File

Step 1. From the HyperTerminal window enter `sz "config.cfg"`
<Enter>.

The filename “`config.cfg`” is an example of a name. You can specify a different filename but it must be in quotes, it must be 8 characters or less and it must end in `.cfg`.

Step 2. From the HyperTerminal window select `Transfer` and `Receive File`.

Step 3. From the `Receive File` dialog enter the path to the folder where you want to save the file or click the `Browse` button and navigate to it.

Step 4. For the Receiving protocol select `Zmodem` and press the `Receive` button.

Step 5. Wait for the “Configuration Download Complete” status message to be displayed on the service terminal indicating successful completion.

If HyperTerminal reports an error, try to receive the file again.

If the SNC 5100 reports an error, make a note of the error code and see the Table 12, “Zmodem Status Codes,” on page 100 for further information.

Loading a Configuration File

Step 1. From the Hyper Terminal window, at the `SN60023 >` command prompt, type `rz` and then press the `Enter` key.

Step 2. From the HyperTerminal window select `Transfer` and `Send File`.

- Step 3.** From the `Send File` dialog enter the path and file name where the firmware file is located or click the `Browse` button and navigate to it. In the `Protocol` field, select `Zmodem` and click the `Send` button.
- Step 4.** Wait for the “Configuration Update Complete” status message to be displayed on the service terminal indicating successful completion.
- Step 5.** Reboot the SNC 5100 for the update to take effect.

For more information, see the `"reboot"` command on page 151.

If HyperTerminal reports an error, try to send the file again.

If the SNC 5100 reports an error, make a note of the error code and see the Table 12, “Zmodem Status Codes,” on page 100 for further information.

Zmodem Status Code Table

The following table shows Zmodem status codes reported by the SNC 5100.

Table 12: Zmodem Status Codes

Status Code	Description
0	OK
-1	Error unwrapping file -bad file, or out of space
-2	Error opening file
-3	Error writing file
-4	Error closing file
-5	Service Port Function Only
-6	Cannot create Debug file - only applicable under lab conditions
-7	Cancelled by host
-8	“Command” not supported
-9	Memory Buffer allocation failed - problem with SNC 5100 memory allocation
-10	No file to send
-11	Garbage - degraded link

Table 12: Zmodem Status Codes

Status Code	Description
-12	CRC Error - degraded link
-13	Timeout Error
-14	File size error - file size is different than it was supposed to be
-15	Invalid file type
-16	Too many retries - degraded link
-17	Position Error - file data has been lost

Setting the Time and Date

Setting the Real Time Clock

Step 1. Use the `rtcDateSet` command to manually set the Real Time Clock.

For more information, see the "`rtcDateSet[year],[month],[dayofmonth],[dayofweek],[hour],[minute],[second]`" command on page 154.

Example:

```
SN60023 > rtcDateSet 2001,1,26,5,9,30,00
value = 0 = 0x0
SN60023 >
```

Step 2. Use the `dateSetFromRTC` command to set the SNC 5100's RTC as the source of date display.

For more information, see the "`dateSetFromRTC`" command on page 116:

Example:

```
SN60023 > dateSetFromRTC
value = 0 = 0x0
SN60023 >
```

Step 3. Use the `tzSet` command to set the timezone. EST is used in the example for Eastern Standard Time.

For more information, see the "tzSet "timezone"" command on page 183.

Example:

```
SN60023> tzSet "EST"  
TZ Set TIMEZONE = EST:EDT:300:040202:101502  
value = 0 = 0x0  
SN60023 >
```

Step 4. Use the date command to confirm.

For more information, see the "date" command on page 115.

Example:

```
SN60023 > date  
SN60023 > FRI JAN 26 9:30:49 2001  
SN60023 >
```

Caution

Use 24 hour time when programming the real time clock.

Caution

The time will be 1 hour off while Daylight Savings time is in effect.

Adding a Host System Running Timeserver

Step 1. To enable the timeserver functionality use the setNettime command.

For more information, see the "setNettime [value]" command on page 163.

Example:

```
SN60023 > setNettime 1  
Nettime 1 value = 0 = 0x0  
SN60023 >
```

Step 2. Add a Host running timeserver to the SNC 5100 using the setTimeHost command.

For more information, see the "setTimeHost" command on page 164.

Example:

```
SN60023 > setTimeHost "butter"  
Time Host butter value = 0 = 0x0  
SN60023 >
```

Step 3. Set the remote system as the source of date/time display using the rdate command.

For more information, see the "rdate "timeserver" " command on page 150.

Example:

```
SN60023 > rdate "butter"  
Get time from butter using UDP/SNTP  
value = 0 = 0x0  
SN60023 >
```

Step 4. 4. Use the tzSet command to set the timezone

In the following example, EST is used for Eastern Standard Time.

Example:

```
SN60023 > tzSet "EST" TZ Set TIMEZONE =  
EST:EDT:300:040202:101502 value = 0 = 0x0  
SN60023 >
```

Step 5. 5. To confirm, use the date command.

For more information, see the "date" command on page 115.

Example:

```
SN60023 > date WED JUL 18 14:51:59 2001 value = 0 = 0x0  
SN60023 >
```

Disabling the Timeserver Host

Step 1. To disable the timeserver functionality, use the setNettime command.

For more information, see the "setNettime [value]" command on page 163.

Example:

```
SN60023 > setNettime 0
Nettime 0 value = 0 = 0x0
SN60023 >
```

Step 2. The time will revert to the time set on the SNC 5100's Real Time Clock.

Synchronizing the Real Time Clock with a Timeserver

Step 1. Use the setTimeHost command to add a host running timeserver to the SNC 5100 system.

For more information, see the "setTimeHost" command on page 164.

Example:

```
SN60023 > setTimeHost "butter"
Time Host butter value = 0 = 0x0
SN60023 >
```

Step 2. Synchronize the SNC 5100's Real Time Clock with the timeserver using the rtcSetCurrent command.

For more information, see the "rtcSetCurrent" command on page 155.

Example:

```
SN60023 > rtcSetCurrent
value = 0 = 0x0
SN60023 >
```

Service Port Command Reference

A “shell” interface provides access to the management and configuration commands referenced in this chapter.

The shell is accessible by connecting a terminal or computer with terminal emulation software to the SNC 5100’s Service Port. For more information, see “Connecting to the Service Port” on page 95.

Managing the SNC 5100

The ADIC Management Console application is the preferred method for managing the SNC 5100. When you use the ADIC Management Console, the operations described in this reference are carried out through the client application.

For more information, see the *ADIC Management Console User Guide*.

The following table is a list of the commands grouped by function.

Commands

This section specifies the commands that are available to control, manage, and service the SNC 5100.

The commands are listed alphabetically by function in Table 13.

The commands are listed in alphabetical order beginning on page 114.

Table 13: Commands Listed Alphabetically byFunction

Command or Command Group	Description	Page
Command and Control		
disableCC	Disable Command and Control Interface	117
enableCC	Enable Command and Control Interface	118

Table 13: Commands Listed Alphabetically byFunction

Command or Command Group	Description	Page
setSnaCCLun	Change Command and Control Interface LUN	164
Data Mover		
sncFeatureEnable	Enable the optional Data Mover feature	171
Diagnostics	Diagnostic commands are located in “Diagnostic Command Reference” on page 187.	
Environmental Sensors		
envMonShow	Display all environmental channel states	118
Ethernet Network		
arptabShow	Display a list of known ARP entries	114
ethAddrGet	Display Ethernet Port address	120
ethAddrSet	Set Ethernet Port address	121
gateAddrGet	Display network gateway address	131
gateAddrSet	Set network gateway address	131
host “add”	Add host table entries	135
host “delete”	Delete network host table entries	136
host “list”	List network host table entries	137
hostNameSet	Change SNC 5100’s network name	138
icmpstatShow	Display statistics for ICMP	138
ifShow	Display Ethernet Port parameters and status	139
inetstatShow	Display all Internet protocol sockets	140
ipstatShow	Display statistics for IP	141
macShow	Display Ethernet Port Media Access Control address	143
mbufShow	Display mbuf statistics	148
route	Edit route table entries	153

Table 13: Commands Listed Alphabetically byFunction

Command or Command Group	Description	Page
route "add"	Add network route table entries	153
route "delete"	Delete network route table entries	154
route "list"	List network route table entries	154
snmpCommunitiesShow	Display list of Community names currently in use	171
snmpReadCommunityAdd	Add Community name with Read permission	173
snmpReadCommunityRemove	Remove Community name Read permission	174
snmpTrapCommunitySet	Set Community name passed with traps	173
snmpWriteCommunityAdd	Add Community name with Write permission	173
snmpWriteCommunityRemove	Remove Community name Write permission	174
tcpstatShow	Display statistics for TCP	181
trapDestAdd	Add recipient IP address to trap destination table	182
trapDestRemove	Remove recipient IP address from trap destination table	182
trapDestShow	Display trap destination table	183
udpstatShow	Display statistics for UDP	183
userAdd	Add a user and password to the password file	184
userDelete	Delete a user from the password file	184
userList	Display the contents of the password file	185
Event Logging		
cleShow	Display Command Log events for the specified LUN	115
cleShowAll	Display Command Log events for all LUNs	115
csClearLogFile	Clear the Event Log	115

Table 13: Commands Listed Alphabetically byFunction

Command or Command Group	Description	Page
loggerDump	Display Event Log records	141
loggerDumpCurrent	Display Event Log records for current boot	142
supportDump	Display information used in troubleshooting	195
Fibre Channel		
fcConnTypeGet	Display the current setting of a Fibre Channel port's connection type	121
fcConnTypeSet	Set the type of connection for a Fibre Channel port	122
fcFibreSpeedGet	Display maximum and current speeds of Fibre Channel port	123
fcFibreSpeedSet	Set Fibre Channel port speed	123
fcGbicShow	Display the GBIC information for each installed GBIC	123
fcPortModeGet	Display the mode for the specified Fibre Channel port	125
fcPortModeSet	Set the mode for the specified Fibre Channel port	126
fcRestart	Restart the specified Fibre Channel port	126
fcShow	Display Fibre Channel interface status	127
fcShowDevs	Display attached SCSI and Fibre Channel Target Devices from Fibre Channel port perspective	129
fcShowNames	Display Node and Port names for Fibre Channels	130
fcTxDisable	Disable a Fibre Channel port transmitter	130
fcTxEnable	Enable or re-enable a Fibre Channel port transmitter	130
setFcFrameSize	Set Frame Size for specific Fibre Channel port	161
setFcHardId	Set Loop ID for specific Fibre Channel port	162

Table 13: Commands Listed Alphabetically byFunction

Command or Command Group	Description	Page
setHost	Set Host OS type for specific Fibre Channel port	162
sysNodeNameModeSet	Change the Fibre Channel Node Name mode	174
sysNodeNameModeShow	Display the current Fibre Channel Node Name mode	175
targets	Display attached SCSI and Fibre Channel Target devices	180
Flash File System		
cd	Set current working path	114
ll	List directory contents in long format	143
ls	List directory contents	143
rm	Remove (delete) a file	153
rz	Initiate a receive Zmodem file transfer session	155
sz	Initiate a send Zmodem file transfer session	180
Health Check		
hlthChkIntervalGet	Display Health Check Interval	134
hlthChkIntervalSet	Set Health Check Interval	134
hlthChkLevelGet	Display Health Check Level	135
hlthChkLevelSet	Set Health Check Level	135
hlthChkNow	Perform a Health Check Now	135
Help		
clehelp	Display Command Log Entry command info	115
diagHelp	Display Diagnostic command info	116
help	Display info for all shell commands	132
hlthChkhelp	Display Health Check command info	134

Table 13: Commands Listed Alphabetically byFunction

Command or Command Group	Description	Page
mapHelp	Display Device Map command info	145
netHelp	Display Network command info	149
snmpHelp	Display SNMP command info	172
userHelp	Display User account command info	185
Product Data and Maintenance		
clearReservation	Force-clear a reservation on the specified target LUN	114
initializeBox	Restore factory defaults by deleting all configuration files including persistent address map and SFM database and then reboot	140
licenseShow	Display information about installed software license keys	141
mapCompressDatabase	Remove inactive device entries and reassign LUNS contiguously in persistent address map database	144
mapRebuildDatabase	Delete and reconstruct persistent address map database	145
mapShowDatabase	Display all persistent address map database entries	146
mapShowDevs	Display persistent address map database entries for attached devices only	147
mapWinnowDatabase	Remove inactive device entries from persistent address map database	148
mapWinnowDatabaseLun	Remove specified device entry from persistent address map database	148
shellLock	Lock or unlock the shell command interface	169
showBox	Display graphic of hardware	194
showVersions	Displays the version of the operational firmware, Power-On-Self-Test (POST), bootrom and Alternate bootrom	170

Table 13: Commands Listed Alphabetically byFunction

Command or Command Group	Description	Page
sysConfigShow	Display configuration settings	174
sysVpdShow	Display Vital Product Data	174
sysVpdShowAll	Display Vital Product Data for all subsystems	174
ridTag	Display and set serial number of replaced Base	152
version	Display Firmware version	185
uptime	Display time elapsed since last boot	184
Scalar Firewall Manager		
sfmAccessApply	Apply access settings and save in Scalar Firewall Manager database	164
sfmAccessClear	Disable Scalar Firewall Manager access to all LUNs for all hosts	165
sfmAccessSet	Set Scalar Firewall Manager access permission for a specific host and a specific LUN range	165
sfmActiveSet	Reactivate Scalar Firewall Manager if inactive	165
sfmConnectionSet	Enter connection information for a specific host	166
sfmFeatureEnable	Enable Scalar Firewall Manager with license key	166
sfmHostShow	Display LUN access permissions for a specific host	166
sfmInactiveSet	Deactivate Scalar Firewall Manager access control allowing all hosts to access all LUNs	167

Table 13: Commands Listed Alphabetically byFunction

Command or Command Group	Description	Page
sfmNameSet	Enter a name for a specific host	167
sfmShow	Display status information for one or all registered hosts	168
sfmSparseAccessSet	Set access permission for a specific host and specific LUNs	169
sfmTypeSet	Enter Operating System information for a specific host	169
SCSI		
fcShowDevs	Display SCSI and Fibre Channel Target Devices from Fibre Channel port perspective	129
scsiAltIdGet	Display SCSI Alternate IDs	156
scsiAltIdSet	Change SCSI Alternate IDs	156
scsiHostChanGet	Display SCSI Host Channel Modes	157
scsiHostChanSet	Set SCSI Host Channel Modes	157
scsiHostIdGet	Display SCSI Host ID Numbers	158
scsiHostIdSet	Set SCSI Host ID Numbers	158
scsiRescan	Rescan for devices on one or all SCSI Channels	158
scsiResetDisableGet	Display SCSI Bus Reset on Power-Up Setting	159
scsiResetDisableSet	Set the SCSI Bus Reset on Power-Up Setting	159
scsiShow	Display SCSI Channels and attached devices	160

Table 13: Commands Listed Alphabetically byFunction

Command or Command Group	Description	Page
scsiTermGet	Display termination status information for SCSI Channels	161
scsiTermSet	Set termination status for the selected channel	161
targets	Display attached SCSI and Fibre Channel Target devices	180
Startup		
diagBoot	Shutdown and restart in Diagnostic mode	191
normalBoot	Shutdown and restart in Normal mode	150
reset	Restart without shutdown	151
reboot	Shutdown and restart	151
Time and Date		
date	Display the date and time	115
dateSetFromRTC	Set the Real Time Clock as the source of date display	116
hostShow	Display the IP address of the system timeserver	138
rdate	Set a remote system as the source of date display	150
rtcDateSet	Manually set the Real Time Clock	154
rtcSetCurrent	Synchronize the Real Time Clock with the timeserver	155
setNettime	Enable or disable timeserver functionality	163
setTimeHost	Add a host running timeserver to the system	164
tzSet	Set the time zone offset from Greenwich Mean Time	183

Each command outputs a status “value” in decimal and hexadecimal after execution and before a new prompt is displayed.

Example :

value = 0 = 0x0

Usually a value of 0 indicates success, but some successful commands return a different value.

arptabShow

The `arptabShow` command displays the contents of the ARP table. The ARP table contains the current Internet-to-Ethernet address mappings. This information may be useful to the LAN administrator.

```
SN60023 > arptabShow
192.168.1.19 at 8:0:20:23:2f:db
value = 0 = 0x0
SN60023 >
```

cd

You can move to a different directory (usually in the flash file system) using the `cd` command.

```
SN60023 > cd "MGMT"
value = 0 = 0x0
SN60023 >
```

clearReservation[devId]

The `clearReservation` command can be used to force-clear a reservation held by a host for the specified target device. It may be necessary to issue this command if a host that has a reservation for a shared device was disconnected from the SNC 5100 without properly shutting down the application software that issued the reservation. If this is the case, other hosts that attempt to access the shared device will repeatedly receive reservation conflict status from the device. Issuing this command may result in resetting the target device.

Parameter	Value
devId	The index of the device (LUN)

```
SN60023 > clearReservation 4
value = 0 = 0x0
SN60023 >
```

The above example shows the `clearReservation` command being used to clear a reservation on a target device at LUN 4.

cleHelp

The `cleHelp` command displays a list of the Command Log Event facility commands.

```
SN60023 > cleHelp
CLE - Command Log Event facility
cleShow <lun> - Displays Logged Events for a specific LUN
cleShowAll - Displays Logged Events for All LUNs
value = 0 = 0x0
SN60023 >
```

cleShow <LUN>

The `cleShow` command displays the last 64 Command Log events for a device at the specified LUN. The manufacturer may request the contents of the command log for diagnostic purposes. Information about interpreting these events is not provided.

cleShowAll

The `cleShowAll` command performs a `cleShow` for all LUNs. The manufacturer may request the contents of the command log for diagnostic purposes. Information about interpreting these events is not provided.

csClearLogFile

The `csClearLogFile` command clears the contents of the event log.

```
SN600726 > csClearLogFile
value = 0 = 0x0
SN600726 >
```

date

The `date` command displays the system's date and the time.

The system may be set to read its local Real Time Clock (see the `dateSetFromRTC` command) or a remote host. See the `rdate "timeserver"` command.

The local Real Time Clock can also be synchronized with a remote timeserver. See the `rtcSetCurrent` command.

```
SN60023 > date
SN60023 > THU JAN 25 20:32:49 2001
SN60023 >
```

dateSetFromRTC

The `dateSetFromRTC` command sets the SNC 5100's RTC as the source of the date display. Use the `date` command to display the date and time.

```
SN60023 > dateSetFromRTC
value = 0 = 0x0
SN60023 >
```

diagBoot

This command is used only to transition the SNC 5100 from normal operation to the special diagnostic mode. The `diagBoot` command first ensures that the `ffs:mt` directory exists. It verifies that the files `diagnstk.o` and `diagnstk.rc` are in the flash file system. If they are in the root directory, it moves them to the `ffs:mt` directory.

It copies the existing bootline to a file in the `ffs:mt` directory on the SNC 5100 and installs a new bootline directing the SNC 5100 to boot using a special diagnostic startup script `ffs:mt/diagnstk.rc`. It renames the persistent map file `config/device.map` as `config/device.bak` (a new file will be generated after rebooting).

Finally, `diagBoot` issues a `reboot` command to put the changes into effect.

Caution

After completing use of the diagnostic commands, use the `normalBoot` command to restore your system to normal operation.

diagHelp

The `diagHelp` command displays a list of the diagnostic commands.

```
SN60023 > diagHelp
** Diagnostic commands: Available in Diagnostic Mode Only **
elTest    Test Ethernet port w/loop-back cable
fcSlotTest <portnum> Test specified Fibre Channel port
```

```
w/loop-back cable
normalBoot Shutdown and restart in normal mode
scsiChannelTest <x,y> Test specified SCSI Channels w/loop-back
cable
```

```
See User's Guide for more information
value = 0 = 0x0
SN60023 >
```

disableCC [option number]

Disable the command and control interface (LUN 0) using the `disableCC` command. Specify one of two option parameters as follows.

Option Number	Value
1	Hides the Command and Control interface and results in Inquiry data returning "device not available" for LUN 0.
2	Completely disables all Command and Control functions

The SNC 5100 is addressable as a SCSI target device for command and control support. On a Fibre Channel Interface, this device will be seen as logical unit number 0, (LUN 0). The LUN 0 device returns a device type of 0Ch in an inquiry command, indicating it is a controller device. Controller devices are defined in the SCSI-3 Controller Commands specification (SCC).

In some cases, it may be desirable to disable this feature. If LUN 0 is disabled, then a device type of 2Ch will be returned in an inquiry to LUN 0, indicating that the device is not presently available at this LUN. LUN 0 will remain reserved for the Command and Control interface and will not be allocated to another target device.

Other commands are available for re-enabling the Command and Control interface or reassigning it to a different LUN rather than hiding or disabling it. See the `enableCC` command and the `setSnaCCLun` command for further information.

Caution

If you enter the `disableCC` command without specifying an option number, it has the same effect as `disableCC 1`

```
SN60023 > disableCC
value = 0 = 0x0
SN60023 >
```

enableCC

To restore the capability to send commands to the command and control interface (LUN 0), use the `enableCC` command. The command is typically used to re-enable the interface after it was disabled by the `disableCC` command.

```
SN60023 > enableCC
value = 0 = 0x0
SN60023 >
```

envMonShow

The `envMonShow` command lists all of the environmental channel states and their current values. Use the command `envMonRangeShow` to restrict output to a display of the ranges relevant to each state. The following channels have been defined:

Channel Name	Description
Air Inlet Temp	Temperature of the air as it enters the unit
Air Outlet Temp	Temperature of the air as it exits the unit
IO Processor Temperature	Temperature of the IO Processor
Input Power: ± 5 Volts	Voltage level of the ± 5 input
Input Power: ± 12 Volts	Voltage level of the ± 12 input
Local Power: ± 2.5 Volts	Voltage level of the local 2.5 supply
Local Power: ± 3.3 Volts	Voltage level of the local ± 3.3 supply
Local Power: ± 3.3 Volts Aux	Voltage level of the local auxiliary ± 3.3 supply
Channel Name	Description
Fan	Fan running (for tachometer fans: RPM of fan)

```
SN60023 > envMonShow
Channel      State  Value
-----
Air Inlet Temperature  Nominal  44 C
```

```

Air Outlet Temperature Nominal 51 C
IO Processor Temperature Warning 31 C
Input Power: ±5 Volts Nominal 5.2 V
Input Power: ±12 Volts Nominal 12 V
Local Power ±2.5 Volts Nominal 3.3 V
Local Power ±3.3 Volts Nominal 3.3 V
Local Power ±3.3 Volts Aux Nominal 3.29 V

```

```

All Power      Nominal
All Temp      Nominal
Sample Count   20

```

```
value = 1 = 0x1
```

envMonRangeShow

The `envMonRangeShow` command specifies operational ranges for the SNC 5100's environmental channels. It displays ranges of values associated with the Nominal, Warning, and Alarm states for voltage, temperature, and fan/blower operation according to the channels defined in the `envMonShow` command:

```

SN600012 > envMonRangeShow
Air Inlet Temp (C):
    Nominal: 5 to 45
    Warning: 4 <= N < 5 or 45 < N <= 50
    Alarm:   N < 4 or N > 50

Air Outlet Temp (C):
    Nominal: 5 to 50
    Warning: 4 <= N < 5 or 50 < N <= 55
    Alarm:   N < 4 or N > 55

IO Processor Temp (C):
    Nominal: 5 to 80
    Warning: 4 <= N < 5 or 80 < N <= 108
    Alarm:   N < 4 or N > 108

```

```
Input Power: +5 Volts (V):
    Nominal: 4.83 to 5.20
    Warning: 4.75 <= N < 4.83 or 5.20 < N <= 5.25
    Alarm:   N < 4.75 or N > 5.25

Input Power: +12 Volts (V):
    Nominal: 11.00 to 12.93
    Warning: 10.75 <= N < 11.00 or 12.93 < N <= 13.18
    Alarm:   N < 10.75 or N > 13.18

Local Power: +2.5 Volts (V):
    Nominal: 2.42 to 2.58
    Warning: 2.36 <= N < 2.42 or 2.58 < N <= 2.62
    Alarm:   N < 2.36 or N > 2.62

Local Power: +3.3 Volts (V):
    Nominal: 3.20 to 3.39
    Warning: 3.13 <= N < 3.20 or 3.39 < N <= 3.46
    Alarm:   N < 3.13 or N > 3.46

Local Power: +3.3 Volts Aux (V):
    Nominal: 3.20 to 3.39
    Warning: 3.13 <= N < 3.20 or 3.39 < N <= 3.46
    Alarm:   N < 3.13 or N > 3.46

Fan :
Nominal: 1; Alarm: 0

value = 1 = 0x1
SN600012 >
```

ethAddrGet

The `ethAddrGet` command displays the IP address of the SNC 5100, specified as 4 decimal numbers separated by periods

```
SN60023 > ethAddrGet
IP Address set to 192.168.1.176
value = 0 = 0x0
SN60023 >
```

ethAddrSet

The `ethAddrSet` command changes the IP address of the SNC 5100. An IP address is specified as 4 decimal numbers separated by periods.

```
SN60023 > ethAddrSet "192.168.1.54"
Host Address set to 192.168.1.54 for Ethernet interface
value = 0 = 0x0
SN60023 >
```

If a netmask is required, specify it after the IP address in “dotted decimal” form.

For example:

```
SN60023 > ethAddrSet "10.0.0.2","255.255.0.0"
Inet Mask set to ffff0000 for Ethernet interface
Write complete
Host Address set to 10.0.0.2 for Ethernet interface
value = 0 = 0x0
SN60023 >
```

fcConnTypeGet [port]

The `fcConnTypeGet` command is used to display the current setting of a Fibre Channel port’s connection type. See also the `fcConnTypeSet` command.

Parameter	Value	Meaning
port	1	The SNC 5100 Connection labeled FC1
	2	The SNC 5100 Connection labeled FC2
connection type	0	Loop
	1	Point-to-point
	2	Loop preferred

The following example shows how the connection type is displayed when Fibre Channel port 1 is specified and its connection type is loop.

```
SN600012 > fcConnTypeGet 1
value = 0 = 0x0
SN600012 >
```

fcConnTypeSet [port],[connection]

The `fcConnTypeSet` command is used to set the type of connection for a Fibre Channel port. See also the `fcConnTypeGet` command

Parameter	Value	Meaning
Port	1	The SNC 5100 Connection labeled FC1
	2	The SNC 5100 Connection labeled FC2
Connection Type	0	Loop
	1	Point-to-Point
	2	Loop Preferred

The following example shows how to set Fibre Channel port 1 connection type to point-to-point.

```
SN60023 > fcConnTypeSet 1,1
value = 0 = 0x0
SN60023 >
```

Caution

You must issue the `fcRestart` command or reboot the SNC 5100 for the new setting to take effect. See the `fcRestart` command for further information.

fcFibreSpeedGet [port]

The `fcFibreSpeedGet` command displays the requested speed of the Fibre Channel port. The actual speed can be viewed in the output of the `fcShow` command. The example below shows that Fibre Channel port 1 has a maximum speed of 1 Gb/sec.

```
SN60023 > fcFibreSpeedGet 1
value = 1= 0x1
SN60023 >
```

Parameter	Value	Meaning
port	1	The SNC 5100Connection labeled FC1

Parameter	Value	Meaning
	2	The SNC 5100 Connection labeled FC2
value =	0	Speed is set to Autorange
	1	Speed is set to 1 Gb/sec
	2	Speed is set to 2 Gb/sec

fcFibreSpeedSet [port],[speed]

The `fcFibreSpeedSet` command sets the Fibre Channel port speed to 1 Gb/sec or 2 Gb/sec for a Fibre Channel port. The port can also be set to autorange, as in the example below

Parameter	Value	Meaning
Port	1	The SNC 5100 connection labeled FC1
	2	The SNC 5100 connection labeled FC2
Speed	0	Autorange
	1	1 Gb/sec
	2	2 Gb/sec

```
SN60023 > fcFibreSpeedSet 1,0
value = 0 = 0x0
SN6002 >
```

Caution

You must issue the `fcRestart` command or reboot the SNC 5100 for the new setting to take effect. The initiator and the device must both be capable of the selected speed. See the `fcRestart` command for further information.

fcGbicShow [port]

The `fcGbicShow` command displays the GBIC information for each installed

GBIC. Specifying the port number is optional.

Parameter	Value	Meaning
Port	1	The SNC 5100 connection labeled FC1
	2	The SNC 5100 connection labeled FC2

SN600023 > fcGbicShow

```
-----
Ctrl : Module :   Module
ID   : Code   :   Information
-----
```

```
1 : 4 : Serial Module Definition Protocol
   : Connector Type ----- SC
   : Nominal Speed ----- 2.5 Gb/sec
   : Link length for 9/125 um ----- 0 meters
   : Link length for 50/125 um ----- 5500 meters
   : Link length for 62.5/125 um -- 2700 meters
   : Vendor Name ----- FINISAR CORP.
   : Vendor OUI ----- 009065
   : Vendor Part Number ----- FTR-8519-3-2.5
   : Vendor Revision ----- 1A
   : Vendor Serial Number ----- B2557JC
   : Vendor Mfg. Date ----- 10-26-2000
   : RX LOS Implemented ----- Yes
   : TX Fault Implemented ----- Yes
   : TX Disable Implemented ----- Yes

2 : 4 : Serial Module Definition Protocol
   : Connector Type ----- SC
   : Nominal Speed ----- 2.5 Gb/sec
   : Link length for 9/125 um ----- 0 meters
   : Link length for 50/125 um ----- 5500 meters
   : Link length for 62.5/125 um -- 2700 meters
   : Vendor Name ----- FINISAR CORP.
   : Vendor OUI ----- 009065
   : Vendor Part Number ----- FTR-8519-3-2.5
   : Vendor Revision ----- 1A

   : Vendor Serial Number ----- B2557K2
   : Vendor Mfg. Date ----- 10-26-2000
   : RX LOS Implemented ----- Yes
   : TX Fault Implemented ----- Yes
   : TX Disable Implemented ----- Yes
-----
```

fcPortModeGet [port]

The `fcPortModeGet` command displays the mode for the specified Fibre Channel port. The default port mode is **Public Target**. See also the `fcPortModeSet` command.

Parameter	Value	Meaning
Port	1	The SNC 5100 connection labeled FC1
	2	The SNC 5100 connection labeled FC2

After the command executes, the number displayed as a value indicates the port mode as follows:

Value	Port Mode
1	Private Target
2	Private Initiator
3	Private Target and Initiator
17	Public Target
18	Public Initiator
19	Public Target and Initiator

The following example shows how the connection type is displayed when Fibre Channel port 1 is specified and the port mode is **Private Target**.

```
SN6002 >fcPortModeGet 1
value = 1 = 0x1
SN6002 >
```

Caution

You must issue the `fcRestart` command or reboot the SNC 5100 for the new setting to take effect. See the `fcRestart` command for further information.

fcPortModeSet [port],[mode]

The `fcPortModeSet` command sets the mode for the specified Fibre Channel port. See also the `fcPortModeGet` command.

The default port mode is **Public Target**. Consequently, if attached to a Fabric device the SNC 5100 will register as a **Target** with the name server. If the port mode is **Private Target**, the SNC 5100 does not register with the name server and the Fabric device will not recognize the SNC 5100 as a **Target**.

The port must be in Initiator mode if you want the SNC 5100 to scan for target devices on the port. When the port is in **Private Initiator** mode, the SNC 5100 only scans for devices on the local loop. If the port mode is in **Public Initiator** mode, the SNC 5100 also scans for devices attached to a Fabric.

Parameter	Value	Meaning
Port	1	The SNC 5100 connection labeled FC1
	2	The SNC 5100 connection labeled FC2
Mode	1	Private Target
	2	Private Initiator
	3	Private Target and Initiator
	17	Public Target
	18	Public Initiator
	19	Public Target and Initiator

```
SN60023 > fcPortModeSet 1,2
value = 0 = 0x0
SN60023 >
```

Caution

You must issue the `fcRestart` command or reboot the SNC 5100 for the new setting to take effect. See the `fcRestart` command for further information.

fcRestart [port]

The `fcRestart` command restarts the specified Fibre Channel port. You

typically use this command to restart the port after changing its configuration settings so that the changes take effect. Issuing this command is an alternative to rebooting the SNC 5100 in order to make the configuration changes take effect.

Caution

This command interrupts traffic.

Parameter	Value	Meaning
Port	1	The SNC 5100 connection labeled FC1
	2	The SNC 5100 connection labeled FC2

The following example shows the display when Fibre Channel port 1 is specified.

```
SN60023 > fcRestart 1
value = 0 = 0x0:
Restart of FC Channel 1 succeeded
```

In order to get the command prompt (e.g. SN60023 >) to show after you have executed the `fcRestart` command, you will need to press the Enter key.

fcShow [level]

The `fcShow` command displays the channel status for each Fibre Channel interface.

Level	Meaning
0 or <blank>	sets the verbosity level to the display in the example below
1	displays the information displayed below, and appends a break-out for each channel that includes Node Type, Node Name, Port Name and Port ID
2	displays the information included at levels 0 and 1, and appends loop ID link stats

```

SN600032 > fcShow
-----Fibre Channel Controllers-----
Ctrlr : PCI Addr : ISP   : Firmware  : Firmware  : Loop : Fabric : Port : E
xt. : Link
      Id : Bs Dv Fn : Type  : State      : Version   : ID   : Attached : Mode : F
IFO : Speed
-----
      1 : 00 07 00 : 2300  : Sync Lost  : 3.00.25   : None : No       : Targ : N
one : 1 Gbps
      2 : 00 08 00 : 2300  : Sync Lost  : 3.00.25   : None : No       : Targ : N
one : 2 Gbps
-----
value = 95 = 0x5f = '_'
SN600032 >

```

Ctrlr Id	Indicates the Port Number for this interface.
PCI Addr	The PCI address of the interface, showing bus, device id, and function number.
ISP Type	The type of Fibre Channel Controller.
Firmware State	The current state of the interface as reported by the Fibre Channel controller. Firmware states are listed below.
Configuration Wait	Firmware is not initialized.
Waiting for AL_PA	Firmware is performing or waiting to perform loop initialization.
Waiting for login	Firmware is attempting port and process logins with all loop ports.
Ready	Indicates that the interface is connected and operational and ready to process SCSI commands. Any other value indicates intermediate states or interface failure.
Sync Lost	The firmware has detected a loss-of-sync condition and is re-synchronizing the serial link receiver. This is the state reported when the Fibre Channel link does not detect a connection to a Fibre Channel device.
Error	The firmware has detected an unrecoverable error condition.
Nonparticipating	The firmware is not participating on the loop since it did not acquire an AL_PA during initialization.
Failed	The firmware is not responding to commands.
Firmware Version	The version of firmware on the Fibre Channel

	controller.
Loop ID	The Fibre Channel Loop ID for this interface. PtoP indicates a point-to-point connection.
Fabric Attached	Indicates whether the port is attached to a Fabric.
Port Mode	Indicates whether the port is set to Target or Initiator mode
Ext. FIFO	Indicates that FIFOs external to the FC controller are on the board. If they are, their size in KB will be output into this column.
Link Speed	Indicates the actual speed of the connection. This figure is only meaningful when the Firmware State is reported as Ready .

Caution

If the **Firmware State** is anything but **Ready**, the information output by this command will be unreliable.

fcShowDevs

The `fcShowDevs` command displays information about the devices that are accessible from each Fibre Channel interface. The display shows the LUN that the SNC 5100 has assigned to each device, the SCSI Channel that the device is attached to, the actual SCSI ID and LUN of the device, the vendor, product, revision and serial number of the device.

In the example, Channel Zoning was used for access control. Fibre Channel 1 has access to all of the attached SCSI tape devices. For the other Fibre Channel interface, Channel Zoning has been setup to restrict access to certain devices.

```
SN60023 > fcShowDevs
FC 1:
LUN Chan Id Lun Vendor Product    Rev SN
-----
 0 0 0 0 ADIC 0338 00000060450d0080
17 3 0 0 OEM  03570C12  5346 000000000305
18 3 0 1 OEM  03570C12  5346 000000000305
19 3 1 0 OEM  03570C12  5346 000000000306
 6 1 1 0 OEM  OEM  DCHS04X   6363 681F775B
 7 1 2 0 OEM  OEM  DCHS04X   6363 682086D3
 8 2 3 0 OEM  OEM  DCHS04X   6363 6820837B
 9 2 4 0 OEM  OEM  DCHS04X   6363 682076AC
FC 2:
LUN Chan Id Lun Vendor Product    Rev SN
-----
```

```

0 0 0 0 ADIC 0338 00000060450d0080
8 2 3 0 OEM OEM DCHS04X 6363 6820837B
9 2 4 0 OEM OEM DCHS04X 6363 682076AC
value = 6 = 0x6
SN60023 >

```

fcShowNames

The `fcShowNames` command displays the node and port names (addresses) of the Fibre Channels.

Ctlr Id	Indicates the Channel Number for the interface
PCI Addr	The PCI address of the interface, showing bus, device id, and function number.
ISPTYPE	The type of Fibre Channel Controller, ISP2300.
Node Name	The Fibre Channel node name for the SNC 5100.
Port Name	The Fibre Channel port name for the interface.

fcTxDisable [port]

The `fcTxDisable` command disables a Fibre Channel port transmitter.

Parameter	Value	Meaning
Port	1	The SNC 5100 connection labeled FC1
	2	The SNC 5100 connection labeled FC2

```

SN60023 > fcTxDisable 1
value = 0 = 0x0
SN60023 >

```

fcTxEnable [port]

The `fcTxEnable` command enables or re-enables a Fibre Channel port transmitter.

Parameter	Value	Meaning
Port	1	The SNC 5100 connection labeled FC1
	2	The SNC 5100 connection labeled FC2

```
SN60023 > fcTxEnable 1
value = 0 = 0x0
SN60023 >
```

gateAddrGet

The `gateAddrGet` command displays the default network gateway address if one has been set. This address is used when connections are made to a different subnet and there are no explicit routes defined for that subnet. Consult your network administrator for more information on the default gateway (sometimes referred to as default router) address.

```
SN60023 > gateAddrGet
Gateway Address set to 192.168.1.1
value = 0 = 0x0
SN60023 >
```

gateAddrSet

The `gateAddrSet` command changes the default network gateway address. This address is used when connections are made to a different subnet and there are no explicit routes defined for that subnet. Consult your network administrator for more information on the default gateway (sometimes referred to as default router) address.

Successful gateAddrSet

```
SN60023 > gateAddrSet "10.0.0.1"
value = 0 = 0x0
SN60023 >
```

Failed gateAddrSet (1)

The following message is received when trying to set a new gateway address and that address is currently unreachable. The following message is sent to the

terminal.

```
SN600726 > gateAddrSet "10.0.0.1"
gateAddrSet: Error setting current gate addr:
S_errno_ENETUNREACH
value = -1 = 0xffffffff = payloadChecksum + 0xffd418a3
```

The new gateway address is written to the bootup parameters to be used at the next boot. If at next boot, the address is reachable, then it will be written to the system file. If at next boot the gateway address is not reachable and therefore not written to the system file, the following message is displayed:

Failed gateAddrSet (2):

```
SN600726 > gateAddrSet "172.16.76.1"
gateAddrSet: Error deleting old gateway addr: S_errno_ESRCH
Gateway Address set to 172.16.76.1 for Ethernet interface
value = 0 = 0x0
SN600726 >
```

help

The help command displays a list of the shell commands.

```
SN60023 > help
```

```
help          Print this list
cleHelp       Print Command Log Entry info
```

```

diagHelp          Print Diagnostic Help info
hlthChkHelp      Print Health Check Help info
ioHelp           Print I/O Utilities Help info
mapHelp          Print Device Map Help info
netHelp          Print Network Help info
snmpHelp         Print SNMP Help info
userHelp         Print User account info
h [n]            Print (or set) shell history
pwd              Print working path
shellLock        Lock or unlock shell command interface
version          Print Version info
whoami           Print user name
clearReservation [devId] Clear reservation on a target (may
reset target)
diagBoot         Shutdown and restart in diagnostic mode
initializeBox    Delete all device maps, restore factory
defaults, reboot
ridTag ["value"] Display and set serial number of replaced
base unit
disableCC [option] Disable Command and Control Interface
                    option 1 - Report as Invalid (AIX mode)
                    option 2 - Fully disabled
enableCC         Enable Command and Control Interface
scsiRescan [chan] Rescan SCSI Channel (all if chan not
specified)
scsiShow         Display info for SCSI Channels
fcShow           Display info for Fibre Channels
fcShowDevs      Display devices available on each Fibre
Channel
fcShowNames     Display Node and Port names for Fibre
Channels
hostTypeShow    Display Default Host Type settings
loggerDump [count] Display Logger Dump Records
loggerDumpCurrent [level] Display Logger Dump Records for
current boot
reboot          Shut down and restart
reset           Restart without shut down
setFcFrameSize [chan],[size] Set FC Frame Size
setFcHardId [chan],[id] Set FC Loop ID
setHost [chan],[OS] Set default host type for FC Channel
OS may be "aix", "nt", "solaris","hpux"
setSnaCCLun     Set LUN for Controller Device (typically
zero)
showBox         Display graphic of current hardware
configuration
sysConfigShow   Display System Config Parameters
sysVpdShow      Display Vital Product Data
sysVpdShowAll   Display Vital Product Data for all

```

```

subsystems
targets          List all known target devices
uptime          Display time since last boot

```

See User's Guide for more information

```

value = 39 = 0x27 = ''
SN60023 >

```

hlthChkHelp

The `hlthChkHelp` command displays a list of the Health Check commands.

```

SN60023 > hlthChkHelp

```

```

hlthChkIntervalGet  - Show Check Interval
hlthChkIntervalSet <interval> - Set Check Interval
hlthChkLevelGet    - Show Check Level
hlthChkLevelSet <level> - Set Check Level
hlthChkNow         - Run Health Check Now

```

See User's Guide for more information

```

value = 0 = 0x0
SN60023 >

```

hlthChkIntervalGet

The current Health Check interval can be viewed using the `hlthChkIntervalGet` command. The example below shows the current interval is 60 minutes.

```

SN60023 > hlthChkIntervalGet
value = 60 = 0x3c = '<'
SN60023 >

```

hlthChkIntervalSet

The Health Check interval controls how often the Health Check process runs. The interval may range from 1 to 65,535 minutes (about 45 days). Set the interval using the `hlthChkIntervalSet` command.

```

SN60023 > hlthChkIntervalSet 60
value = 0 = 0x0
SN60023 >

```

hlthChkLevelGet

To display the current Health Check level, use the `hlthChkLevelGet` command. The example below shows that the current level is 2.

```
SN60023 > hlthChkLevelGet
value = 2 = 0x02
SN60023 >
```

hlthChkLevelSet

To set the Health Check level, use the `hlthChkLevelSet` command. The example below shows setting the level to 3.

```
SN60023 > hlthChkLevelSet 3
value = 0 = 0x0
SN60023 >
```

hlthChkNow

The `hlthChkNow` function causes the SNC 5100 to execute an immediate, level 4 Health Check. Results are displayed that will indicate which devices or subsystems failed the check.

```
SN60023 > hlthChkNow
Health Check: Starting level 4 check
Health Check: Step 1 -- Checking System
Health Check: Step 2 -- Checking Interfaces
Health Check: Step 3 -- Checking Devices
Health Check: Step 4 -- Checking Device States
Health Check: Passed

value = 0 = 0x0
SN60023 >
```

host "add", "hostname", "ipAddress"

The `host "add"` command adds the named host to the host table and host file. If the IP address is already assigned to a host, then the new name is added as an alias for the host. The `host "add"` command is invoked to add known hosts and their IP addresses. Alias names are supported, allowing multiple names to a single host.

The `host` utilities maintain a host file, `nvfs:/mgnt/hosts`, which is used

at system startup to initialize the network hosts table. This table associates network names with IP addresses. Use of the `hosts` table is entirely optional, but might facilitate frequently needed connections. Each host entry is a single line of the format:

```
IP-address      official_host_name  nicknames ...
```

where

IP-address is a text string in standard IP Address format (i.e., 10.0.0.2).

official_host_name is the first name selected for this host.

nicknames is an optional list of additional aliases for the host (separated by spaces).

The following is an example of host file contents.

```
192.168.1.90 bruno
200.0.0.42 socrates
200.0.0.45 plato
200.0.0.47 fred
```

Note

The host file does not exist until you enter the host “add” command.

```
SN60023 > host "add","plato","200.0.0.45"
SN60023 >
```

host “delete”,“hostname”

The host “delete” command deletes the named host from the hosts table and hosts file. If the `hostname` is an alias, then only the alias is removed. If `hostname` is the official host name, the entry and all aliases are removed.

The `host` utilities maintain a host file, `nvfs : /mgnt/hosts`, which is used at system startup to initialize the network hosts table. This table associates network names with IP addresses. Use of the `hosts` table is entirely optional, but might facilitate frequently needed connections. Each host entry is a single line of the format:

```
IP-address      official_host_name  nicknames ...
```

where

IP-address is a text string in standard IP Address format (i.e., 10.0.0.2).

official_host_name is the first name selected for this host.

nicknames is an optional list of additional aliases for the host (separated by spaces).

The following is an example of host file contents.

```
192.168.1.90 bruno
200.0.0.42 socrates
200.0.0.45 plato
200.0.0.47 fred

SN60023 > host "delete", "plato"
SN60023>
```

host "list"

The host "list" command prints the content of the hosts file.

The `host` utilities maintain a host file, `nvfs:/mgnt/hosts`, which is used at system startup to initialize the network hosts table. This table associates network names with IP addresses. Use of the `hosts` table is entirely optional, but might facilitate frequently needed connections. Each host entry is a single line of the format:

```
P-address      official_host_name  nicknames ...
```

where

IP-address is a text string in standard IP Address format (i.e., 10.0.0.2).

official_host_name is the first name selected for this host.

nicknames is an optional list of additional aliases for the host (separated by spaces).

The following is an example of host file contents.

```
SN60023 > host "list"
192.168.1.90 bruno
200.0.0.42 socrates
200.0.0.45 plato
200.0.0.47 fred
value = 0 = 0x0
SN60023 >
```

hostNameSet

The `hostNameSet` command changes the network name of the SNC 5100. The shell prompt will be set to the new host name.

```
SN60023 > hostNameSet "foster"
Target hostname set to foster
value = 0 = 0x0
foster >
```

hostShow

The `hostShow` command displays the IP address and alias (if any) of the unit processing the `hostShow` command, the localhost and the timeserver host.

```
SN600012 > hostShow
hostname          inet address      aliases
-----          -
SN600012          192.168.1.172
localhost         127.0.0.1
host              192.168.1.127
value = 0 = 0x0
SN600012 >
```

hostTypeShow

The `hostTypeShow` command displays the host type setting for each Fibre Channel. The possible host types are **AIX, AS400, Gateway, FCR-2, HP-UX, Linux, NT (includes Windows 2000), Netware, Generic, Solaris, Autosense/NT, or Dell PV-136T-FC.**

```
SN60023 > hostTypeShow
FC 1: Type 2 - nt
FC 2: Type 1 - solaris
value = 0 = 0x0
SN60023 >
```

The output in the example could be the result of the user's choosing either "Linux" or "Solaris" for the host attached to FC2.

icmpstatShow

The `icmpstatShow` command displays ICMP statistics for the Ethernet

network. Interpreting these statistics requires detailed knowledge of Internet networking protocols. This information may be useful to the LAN administrator.

```
SN60023 > icmpstatShow
ICMP:
  0 call to icmp_error
  0 error not generated because old message was icmp
  0 message with bad code fields
  0 message < minimum length
  0 bad checksum
  0 message with bad length
Input histogram:
  destination unreachable: 1
  0 message response generated
value = 30 = 0x1e
SN60023 >
```

ifShow

The `ifShow` command is used to show the Ethernet port parameters and status as shown below. The SNC 5100 will show two devices. `ibmEmac` is the Ethernet port. `lo` is the local loopback port.

```
SN600752 > ifShow
ibmEmac (unit number 0):
  Flags: (0x8063) UP BROADCAST MULTICAST ARP RUNNING
  Type: ETHERNET_CSMACD
  Internet address: 172.16.76.211
  Broadcast address: 172.16.255.255
  Netmask 0xffff0000 Subnetmask 0xffff0000
  Ethernet address is 00:60:45:17:02:f0
  Metric is 0
  Maximum Transfer Unit size is 1500
  114192 packets received; 364 packets sent
  114023 multicast packets received
  116 multicast packets sent
  0 input errors; 0 output errors
  0 collisions; 0 dropped
lo (unit number 0):
  Flags: (0x8069) UP LOOPBACK MULTICAST ARP RUNNING
  Type: SOFTWARE_LOOPBACK
  Internet address: 127.0.0.1
  Netmask 0xff000000 Subnetmask 0xff000000
```

```

Metric is 0
Maximum Transfer Unit size is 32768
0 packets received; 0 packets sent
0 multicast packets received
0 multicast packets sent
0 input errors; 0 output errors
0 collisions; 0 dropped
value = 29 = 0x1d
SN600752 >

```

inetstatShow

The `inetstatShow` command displays statistics about Internet protocol sockets for the Ethernet network. Interpreting these statistics requires detailed knowledge of Internet networking protocols. This information may be useful to the LAN administrator.

```

SN60023 > inetstatShow
Active Internet connections (including servers)
PCB  Proto Recv-Q Send-Q Local Address  Foreign Address (state)
-----
c1fee18c TCP  0  0 192.168.1.59.23 206.0.64.117.4239
ESTABLISHED
c1fee40c TCP  0  0 0.0.0.0.52787  0.0.0.0.0 LISTEN
c1fee58c TCP  0  0 0.0.0.0.21  0.0.0.0.0 LISTEN
c1fee68c TCP  0  0 0.0.0.0.23  0.0.0.0.0 LISTEN
c1feea0c TCP  0  0 0.0.0.0.513  0.0.0.0.0 LISTEN
c1fee48c UDP  0  0 0.0.0.0.161  0.0.0.0.0
value = 1 = 0x1
SN60023 >

```

initializeBox

The `initializeBox` command removes configuration files, such as management configuration and SCSI device maps, and then prompts to reboot.

Caution

Use this function with care as data may be lost as a result of devices moving to different LUNs when the mapping database is removed. Make sure all I/O has been stopped.

ipstatShow

The `ipstatShow` command displays Internet protocol statistics for the Ethernet network. Interpreting these statistics requires detailed knowledge of Internet networking protocols. This information may be useful to the LAN administrator.

```
SN60023 > ipstatShow
  total 8380
  badsum 0
  tooshort 0
  toosmall 0
  badhlen 0
  badlen 0
  fragments 0
  fragdropped 0
  fragtimeout 0
  forward 0
  cantforward 0
  redirectsent 0
```

```
value = 1 = 0x1
SN60023 >
```

licenseShow

The `licenseShow` command displays information about software license keys that are installed and the corresponding features that are available. The following example shows an SNC 5100 that contains a license key for the SFM and Data Mover features.

```
SN60023 > licenseShow
License "wsk96-sd59a": Valid
Features:
SFM,
Data Mover.
value = 1 = 0x1
SN60023 >
```

loggerDump [number]

Dump records from the system event log to the console using the `loggerDump` command. A numeric parameter may be used to indicate the number of events to display. With no parameter specified, all events in the log

file are displayed starting with the most recent events.

```
SN600393 > loggerDump
*** Dumping 10 of 10 records ***
SEQUENCE  TIME                               CODE   DESCRIPTION
0001      FEB 21 2002 17:58:06                31     NOTICE: LOGGING STARTED
0002      FEB 21 2002 17:58:06                14     CS 1: Rev. 4.11.05 Built
Feb  5 2002, 18:03:37
0003      FEB 21 2002 17:58:12                14     SFM1: Enabled: State =
Active, Hosts = 1
0004      FEB 21 2002 17:58:12                14     FCAL 1: External FIFO
depth is unknown (0x0700)
0005      FEB 21 2002 17:58:12                14     FCAL 2: External FIFO
depth is unknown (0x0700)
0006      FEB 21 2002 17:58:13                14     FCAL 1: LIP Initiated
0007      FEB 21 2002 17:58:13                14     FCAL 2: LIP Initiated
0008      FEB 21 2002 17:58:13                28     USCSI 2: Bus RESET
0009      FEB 21 2002 17:58:13                28     USCSI 4: Bus RESET
0010      FEB 21 2002 17:58:13                14     System 0: ES 1 CC 0/0
Prd 2 Snp 1 HP 1 fMax 254 RstI 0
```

SN600393 >

loggerDumpCurrent [level]

Dump records from the system event log to the console with the `loggerDumpCurrent` command. Only records logged since the system was booted are dumped. Level specifies the event log level for the events as follows:

Table 14: Event Viewing Levels

Number	Level	Explanation
0	Notice	Events recorded in the Event Log but not displayed by the Event Viewer
1	Warning	Includes events that should always be reported, such as device removals, and changes to temperature or power systems
2	Information	Includes events that might result in later problems

```
SN600393 > loggerDumpCurrent 2
*** Dumping 5 current records (of 13 total) with level <= 2 ***
SEQUENCE  TIME                               CODE  DESCRIPTION
0007      FEB 26 2002 19:01:14      28    USCSI 2: Bus RESET
0008      FEB 26 2002 19:01:14      28    USCSI 4: Bus RESET
0010      FEB 26 2002 19:01:14      29    Mapping 1: Target Device
Added: index 0
, handle 0x08fda380
0012      FEB 26 2002 19:01:26      29    Mapping 1: Target Device
Added: index 1
, handle 0x09ffcf08
0013      FEB 26 2002 19:01:27      70    NOTICE: Reboot Complete
value = 0 = 0x0
SN600393 >
```

ls or ll

The SNC 5100 contains a file system in its flash memory. Use the `ls` command to display the files as shown below.

```
SN60023 >
license.dat
sna.rc
vxWorks.st
value = 0 = 0x0
SN60023 >
```

To obtain detailed information about the file, use the `ll` command instead.

macShow

The `macShow` command displays the Media Access Control (MAC) address for

the Ethernet interface.

```
SN60023 > macShow
Enet MAC Address: 0.60.45.d.0.80
value = 33 = 0x21 = '!'
SN60023 >
```

mapCompressDatabase

Caution

Compressing the map database will cause device addresses to change unpredictably. Use this command only when no host systems are expecting devices to remain at their current addresses.

Occasionally, it may be necessary to eliminate inactive entries and reorder the active entries in the Persistent Device Map database. The `mapCompressDatabase` command removes entries for devices that are no longer present and reassigns existing device entries to new addresses. The devices will be assigned new addresses immediately and hosts must rescan for devices or be rebooted.

This may be required when a host system has a limited number of logical units that may be supported, and changing devices on the SNC 5100 has caused the logical unit numbers to increase beyond the host's supported level.

When you run this command you will be given the option of also clearing the SFM access settings. Because devices will be assigned new addresses, clearing the SFM database ensures that hosts will not have access to the wrong LUNs. Accepting this option requires that the system administrator must reassign SFM access permissions between the hosts and LUNs.

```
SN60023 > mapCompressDatabase
This command will compress the Persistent Device Map.
```

```
Existing SFM Access Settings may become invalid and
should be cleared because LUN assignments may change!
Do you want to compress the Device Map? (y or n) y
0xc1689ac0 (tShell): Wrote 23 device maps to file
'nvfs:config/device.map'
Device Map Compressed
- Do you want to clear SFM Access Settings? (y or n) y
SFMAccess Cleared
value = 23 = 0x17
```

SN60023 >

If you have not been using SFM the output of this command will not reference SFM.

```
SN60023 > mapCompressDatabase
This command will compress the Persistent Device Map.
```

```
Do you want to compress the Device Map? (y or n) y
0xc1689ac0 (tShell): Wrote 23 device maps to file
'nvfs:config/device.map'
Device Map Compressed
```

```
value = 23 = 0x17
```

SN60023 >

mapHelp

The mapHelp command displays a list of the persistent address map database commands.

```
SN60023 > mapHelp
```

```
mapCompressDatabase - Compress Device Map Database
(reboot required)
mapRebuildDatabase - Rebuild Device Map Database (reboot
required)
mapShowDatabase - Show the Map Database
mapShowDevs - Show currently attached devices
mapWinnowDatabase - Remove unattached devices from database
```

See User's Guide for more information

```
value = 0 = 0x0
```

SN60023 >

mapRebuildDatabase

Caution

Clearing the map database will cause device addresses to change unpredictably. Use this command only when no host systems are expecting devices to remain at their current addresses. The SNC 5100 must be rebooted after executing this command.

Occasionally, it may be necessary to eliminate the Persistent Device Map database entirely, allowing the existing devices to have new addresses assigned.

The `mapRebuildDatabase` command deletes the current database. When the SNC 5100 is next booted, the devices found will be assigned new addresses.

When you run this command you will be given the option of also clearing the SFMaccess settings. Because devices will be assigned new addresses, clearing the SFMdatabase ensures that hosts will not have access to the wrong LUNs. Accepting this option requires that the system administrator must reassign SFM access permissions between the hosts and LUNs.

This may be required when a host system has a limited number of logical units that may be supported, and changing devices on the SNC 5100 has caused the logical unit numbers to increase beyond the host's supported level.

```
SN60023 > mapRebuildDatabase
This command will clear the Persistent Device Map.
Existing SFM Access Settings may become invalid and
should be cleared because LUN assignments may change!
These changes will take effect when the SNC 5100 is rebooted.
Do you want to clear the Device Map? (y or n) y
Removing the Persistent Device Map
Device Map Cleared - Do you want to clear SFM Access Settings?
(y or n) y
SFM Access Cleared - Reboot SNC 5100 (y or n) y== reboot
SN60023 >
```

mapShowDatabase

The SNC 5100 maintains a database of attached devices, to insure that each time a host attaches to it, the target devices are seen at a consistent address. The database will list not only the devices presently connected, but also devices that have previously been connected. If a previously attached device is later reattached, it will be assigned back to its previous address. Use the `mapShowDatabase` command to display the persistent device map table.

```
SN60023 > mapShowDatabase
devId Type Chan tId tLun UID
-----
000 SNA 127 127 127 00000060:450d00c0
001 SCSI 001 003 000 00000060:450d00c0
002 SCSI 001 002 000 00000060:450d00c0
003 SCSI 001 001 000 00000060:450d00c0
004 SCSI 002 002 000 00000060:450d00c0
005 SCSI 002 000 000 00000060:450d00c0
006 SCSI 002 006 000 00000060:450d00c0
007 SCSI 002 009 000 00000060:450d00c0
008 SCSI 002 002 001 00000060:450d00c0
```

```

009 SCSI 002 005 000 00000060:450d00c0
010 SCSI 002 005 001 00000060:450d00c0
011 SCSI 001 000 000 00000060:450d00c0
012 SCSI 001 006 000 00000060:450d00c0
value = 0 = 0x0
SN60023 >

```

devIdThe index of the device in the database.

TypeThe type of interface where the device is connected. SNA indicates an internal device. SCSI or Fibre Channel indicate I/O interfaces.

ChanThe channel number of the interface where the device is attached

TIdTarget ID mapping for SCSI Initiators

TLunTarget LUN mapping for SCSI Initiators

UIDFor a Fibre Channel interface, the Unique ID of the device. For SCSI interface, the SNC 5100's Unique ID.

mapShowDevs

The SNC 5100 maintains a cross-reference map of device addresses. Information about the presently attached and available devices in the map can be displayed using the mapShowDevs command.

```

SN60023 > mapShowDevs
devId Type Chan iId iLun UID      tId tLun Handle  Itl
-----
000 SNA 127 127 127 00000060.450d00c0 001 000 c0ec2600h 00000000h
009 SCSI 002 005 000 09000060.450d00c0 255 255 c1f9e090h 00000000h
010 SCSI 002 005 001 0a000060.450d00c0 255 255 c0ad2590h 00000000h
012 SCSI 001 006 000 0c000060.450d00c0 255 255 c1ffdf10h c1ffdc80h
value = 0 = 0x0
SN60023 >

```

TypeThe type of interface where the device is attached to the SNC 5100.

ChanThe channel number of the interface

iIdFor a SCSI interface only - device ID of the device

iLunFor a SCSI interface only – Logical unit number of the device.

UIDFor a Fibre Channel interface – Unique ID of the device. For SCSI interface, a constructed Unique ID based on the SNC 5100's Unique ID.

tIdTarget ID mapping for SCSI Initiators

tLunTarget LUN mapping for SCSI Initiators

Handle An internal pointer used for some diagnostic operations.

Itl An internal pointer used for some diagnostic operations.

mapWinnowDatabase

Occasionally, you may want to eliminate inactive entries from the database. The `mapWinnowDatabase` command reduces the database to only the devices presently attached. The address mapping of the current devices will not be altered.

```
SN60023 > mapWinnowDatabase
0xc0ac8340 (tShell): Wrote 4 device maps to file
'nvfs:config/device.map'
value = 4 = 0x4
SN60023 >
```

Caution

Winnowing the database might cause unattached devices to change addresses unpredictably if they are reattached. Use this command only when you are sure that the devices you are interested in are connected and available to the SNC 5100. You must reboot the SNC 5100 after executing this command for the new setting to take effect.

mapWinnowDatabaseLun [dev ID]

The `mapWinnowDatabaseLun` command acts like the existing function `mapWinnowDatabase` except that it operates on only one specified LUN, which is input as a parameter. The `mapWinnowDatabaseLun` command operates against the device list output by the `mapShowDatabase` command. Issue the `mapShowDatabase` command before and after issuing the `mapWinnowDatabaseLun` command to verify functionality.

The `mapWinnowDatabaseLUN` command frees the LUN for use in the device map. If the LUN is currently assigned to an attached device, no action is taken. If the LUN refers only to historical data (device not currently attached), the LUN is freed for reuse.

```
Fibre Bridge > mapWinnowDatabaseLun 14
value = 31 = 0x1f
Fibre Bridge >
```

mbufShow

The `mbufShow` command displays statistics about the distribution of mbufs on the Ethernet network. Interpreting these statistics requires detailed knowledge of Internet networking protocols. This information may be useful to the LAN

administrator.

```
SN60023 > mbufShow
type  number
-----
FREE  :   23
DATA  :    0
HEADER:    1
SOCKET:    0
PCB   :   11
RTABLE:    3
HTABLE:    0
ATABLE:    0
SONAME:    0
ZOMBIE:    0
SOOPTS:    0
FTABLE:    0
RIGHTS:    0
IFADDR:    2
TOTAL :   40
number of mbufs: 40
number of clusters: 4
number of interface pages: 0
number of free clusters: 4
number of times failed to find space: 0
number of times waited for space: 0
number of times drained protocols for space: 0
value = 47 = 0x2f = '/'
SN60023 >
```

netHelp

The netHelp command displays a list of the Ethernet network commands.

```
SN60023 > netHelp

arptabShow - Display a list of known ARP entries
ethAddrSet "inetaddr", "netmask" - set IP Address
gateAddrGet          - Display Default IP gateway
gateAddrSet "inetaddr" - set Default IP gateway
host "<func>", "hostname", "inetaddr"
  func - "add" - add to host table
        - "delete" - delete from host table
        - "list" - list host table
hostNameSet - set host name
icmpstatShow - Display statistics for ICMP
ifShow      - Display info about network interfaces
```

```
inetstatShow - Display all Internet protocol sockets
ipstatShow  - Display statistics for IP
macShow     - Display Media Access Control Address
mbufShow    - Display mbuf statistics
route "<func>","destination","gateway"
  func - "add" - add route to route table
        - "delete" - delete route from route table
        - "list" - list route table
tcpstatShow - Display statistics for TCP
udpstatShow - Display statistics for UDP
```

See User's Guide for more information

```
value = 0 = 0x0
SN60023 >
```

normalBoot

Certain commands and tests are only available in diagnostic mode. Switching to diagnostic mode saves all configuration parameters so that they are restored before returning to normal operation. Use the `normalBoot` command to restore the SNC 5100 to normal operating conditions.

This command is used only to transition an SNC 5100 from the special diagnostic mode to normal operations. It restores the bootline that was copied by `diagBoot`. The new persistent device map is erased, and the original map file is renamed `config/device.map` restoring it for use when the SNC 5100 reboots. The `normalBoot` command will then reboot the unit.

rdate "timeserver"

The `rdate "timeserver"` command sets the system date and time to be read from a remote system. The `setTimeHost` command on page 164 must already have been entered before the `rdate "timeserver"` command is issued. To see data from the new setting, use the `date` command. To set the date and time to be read from a remote system named "Cronos," enter the following command:

```
SN60023 > rdate "Cronos"
value = 0 = 0x0
SN60023 >
```

reboot

The `reboot` command requests that the SNC 5100 shut down existing operations and then restart. This is the preferred method of restarting the SNC 5100. There are processes running within the SNC 5100 that may have writes pending to files within the flash file system. Following a `reboot` command, these processes flush their data to the flash file system, and the flash file system writes all pending data out to the flash memory. Only after all pending data has successfully been written to flash, will the SNC 5100 start a reset cycle.

```
SN60023 > reboot
```

reserveShow [level]

The `reserveShow` command outputs a list of devices with reservations. By adding the flag “1” a list of all devices is output.

Table 15: reserveShow Viewing Levels

Level	Explanation
<blank>	Show target devices with reservations
1	Show all target devices regardless of whether a reservation is held or not

```
SN600393 > reserveShow
Idx Tdev      Vendor  Product      Rev  | Reservation ITL
Host's Port Name
-----|-----
value = 0 = 0x0
```

```
SN600393 > reserveShow 1
Idx Tdev      Vendor  Product      Rev  | Reservation ITL
Host's Port Name
-----|-----
  0 0x8fda380 ADIC    SNC 5100     40b5 |
  1 0x9ffc08 IBM     DNES-309170W SA30  |
value = 0 = 0x0
SN600393 >
```

reset

The `reset` command immediately initiates a reset cycle. Any pending data

writes to the flash file system will be lost. This operation is not typically used. The `reboot` command should be used to gracefully shutdown and restart the SNC 5100.

```
SN60023 > reset
```

restartScsi [channel]

The `restartScsi` command restarts the specified SCSI Channel without issuing a bus reset.

```
SN60023 > restartScsi 1
value = 0 = 0x0
SN60023>
```

ridtag ["value"]

The `ridtag` command is used to change the replacement identifier (RID) tag for the SNC 5100 after it has been replaced by the service representative. This should be the final step after replacing and verifying that the replacement unit is performing satisfactorily.

The `sysVpdShow` command will display the RID tag. Before replacing the SNC 5100, you must determine the existing RID tag, if there is one, or the original serial number if no replacement has been made.

If the `ridtag` command is entered with a string, that string becomes the RID tag recorded for the unit.

```
SN60023 > ridtag "12D345677"
*** value = 0 = 0x0
```

If a string is not entered, the existing RID tag is displayed.

```
SN60023 > ridtag
RID Tag = 12D345677
value = 0 = 0x0
SN60023 >
```

On original equipment, the RID tag will be blank.

rm

To remove a file, use the `rm` command and specify the file name in quotes:

```
SN60023 > rm "file.ext"
```

route

The `route` utilities maintain a route file, `nvfs:/mgmt/route`, which is used at system startup to initialize the network routing table. Each route entry is a single line of the format:

```
destination:gateway
```

where

`destination` is an IP address (for a subnet or host) or the name of a host that is described in the hosts file.

`gateway` is an IP address or the name of a gateway to a host. The gateway must be a device on the local subnet.

An IP address is a text string in standard IP Address format (i.e., 10.0.0.2). A host or gateway name must be listed in the hosts file.

Here is an example of the contents of the route file.

```
socrates:bruno  
10.0.0:bruno
```

The first line instructs the system to reach the host “socrates” by directing the IP packets to the host “bruno”. The second example shows how all traffic for the subnet 10.0.0 (implied netmask is 255.255.255.0) is sent to the host “bruno” for forwarding. By default, no routes are defined in the route file.

The `route` command is invoked to add, remove, and list the route table.

route “add”, “destination”, “gateway”

The `route “add”` command adds a route to the destination through the gateway.

```
SN60023 > route "add", "200.0.0", "bruno"  
SN60023 >
```

route “delete”, “destination”, “gateway”

The route “delete” command removes a route to the destination through the gateway.

```
SN60023 > route "delete", "200.0.0", "bruno"
SN60023 >
```

route “list”

The route “list” command lists the existing routes.

```
SN60023 > route "list"
Destination SNC 5100
-----
socrates      bruno
Destination SNC 5100
-----
200.0.0      bruno
value = 0 = 0x0
SN60023 >
```

rtcDateSet [year], [month], [dayofmonth], [dayofweek], [hour], [minute], [second]

The rtcDateSet command allows you to set the date and time manually.

- You must use a 24-hour clock.
- All parameters are digits.
- The year can be either two or four digits.
- Single digit months or hours should not be filled out with leading zeroes.
- A digit from 1-7 needs to be entered for the [dayofweek] parameter, but it doesn't matter what you enter, since the command will automatically correct it if it is wrong.

To display the new time and date data after entering the rtcDateSet command, enter the date command.

To set the RTC to 9:35 A.M. on Friday, January 26, 2001, enter the following

string:

```
SN60023 > rtcDateSet 2001,1,26,5,9,30,00
value = 0 = 0x0
SN60023 >
```

Caution:

The time will be one hour off when Daylight Savings Time is in effect.

rtcSetCurrent

The `rtcSetCurrent` command is used after the `rdate "timeserver"` command in order to synchronize the local Real Time Clock with the timeserver running on a remote host. Use the `date` command to see the synchronized settings.

```
SN60023 > rtcSetCurrent
value = 0 = 0x0
SN60023 >
```

rz

The `rz` command initiates a receive Zmodem file transfer session. You use this command when you want to download a file from the service terminal to the SNC 5100. The file can be either a firmware or configuration file. After issuing this command, you start the file transfer from the service terminal by initiating a send file operation that uses Zmodem protocol.

The example below shows the `rz` command when it is used to receive a file that contains operational firmware. The SNC 5100 extracts individual firmware modules from the file and saves them temporarily in memory. After the file transfer has completed, the SNC 5100 copies the firmware modules to nonvolatile flash memory. The SNC 5100 must be rebooted to use the updated firmware.

```
SN60023 > rz
**B000000023be50
Firmware Update in Progress....
Found Image File BOOTROM.IMG - loading
.....Found Image File IPOST.IMG - loading
.....Found Image File SPOST.IMG - loading
Firmware Update Complete. Reboot for Update to Take Effect.
value = 0 = 0x0
```

```
SN60023 >
The example below shows the rz command when it is used to
receive a file that contains configuration parameters. See also
the sz command for information about sending a configuration
file.
```

```
SN60023 > rz
**B000000023be50
Configuration Update in Progress....
Configuration Update Complete. Reboot for Update to Take
Effect.
value = 0 = 0x0
SN60023 >
```

scsiAltIdGet [channel]

The `scsiAltIdGet` command displays the alternate ID number for a specified channel. If no channel is specified, alternate IDs are displayed for all SCSI channels.

```
SN60023 > scsiAltIdGet
SCSIbus AltId -----
SCSI 1 1
SCSI 2 6
value = -1 = 0xffffffff
SN60023 >
```

scsiAltIdSet [channel],[id]

The `scsiAltIdSet` command sets the Alternate Id for the specified SCSI Channel.

Parameter	Value
SCSI Channel Number	1 - 4
ID	0 -15

```
SN60023 > scsiAltIdSet 2,6
Alternate Id set to 6 for SCSI 2
will take effect upon reboot
value = 0 = 0x0
```

SN60023 >

Caution

You must reboot the SNC 5100 after executing this command for the new setting to take effect.

scsiHostChanGet [channel]

The `scsiHostChanGet` command displays Host Channel modes for a SCSI channel. If no channel is specified, Host Channel modes are displayed for all SCSI channels.

```
SN60023 > scsiHostChanGet
SCSIbus HostChan -----
SCSI 1 Channel is Target
SCSI 2 Channel is Initiator
value = -1 = 0xffffffff
SN60023 >
```

scsiHostChanSet [channel],[mode]

The `scsiHostChanSet` command sets the Channel Mode to **Target** or **Initiator** for the specified SCSI Channel.

Parameter	Value	Meaning
SCSI Channel Number	1 - 4	Selected Channel
Mode	0	Initiator
	1	Target

```
SN60023 > scsiHostChanSet 2,1
Host Chan set to TARGET for SCSI 2 will take effect upon reboot
value = 0 = 0x0
SN60023 >
```

Caution

You must reboot the SNC 5100 after executing this command for the new settings to take effect.

scsiHostIdGet [channel]

The `scsiHostIDGet` command displays the Host ID number for a specified SCSI Channel. If no channel is specified, Host IDs are displayed for all SCSI channels.

```
SN60023 > scsiHostIdGet
SCSIbus HostId -----
SCSI 1 7
SCSI 2 7
value = -1 = 0xffffffff
SN60023 >
```

scsiHostIdSet [channel],[id]

The `scsiHostIdSet` command sets the Host ID for a specified SCSI Channel.

Parameter	Value
Channel Number	1 - 4
ID	0 - 15

```
SN60023 > scsiHostIdSet 2,7
Host Id set to 7 for SCSI 2
will take effect upon reboot
value = 0 = 0x0
SN60023 >
```

Caution

You must reboot the SNC 5100 after executing this command for the new settings to take effect.

scsiRescan [channel]

The command `scsiRescan` requests a SCSI rescan for new devices. If channel is specified (1 or 2), then only that channel is scanned. Otherwise, if channel is not specified or if channel is 0, then all channels are scanned.

```
SN60023 > scsiRescan 2
Done
```

```
value = 0 = 0x0
SN60023 >
```

Rescanning a SCSI bus may delay I/O commands pending on that bus for several seconds. Do not rescan SCSI buses when this delay may not be tolerated. When possible, only scan the bus where a new device has been added.

When a device is discovered, there may be further device specific initialization that continues after the scan has completed in which case the device may not show up immediately when you issue the `fcShowDevs` command. Tape and Changer devices that indicate Ready status are available on scan completion.

If a SCSI target device should require replacement, remove the old device, set the new device to the same SCSI bus ID as the old device and attach it to the same channel. Rescan the channel to update the configuration data. The new device should be available to host systems with the same LUN as the old device.

scsiResetDisableGet [channel]

The `scsiResetDisableGet` command displays the SCSI Bus Reset On Power Up is enabled. False means that SCSI Bus Reset On Power Up is disabled.

```
SN60023 > scsiResetDisableGet
SCSIbus Reset Disable -----
SCSI 1 TRUE
SCSI 2 FALSE - default
value = -1 = 0xffffffff
Sn60023 >
```

scsiResetDisableSet [channel],[mode]

The `scsiResetDisableSet` command sets the SCSI Bus Reset On Power Up for the specified SCSI channel. False is default and enables reset of SCSI bus on power-up. True disables SCSI bus reset on power-up.

Parameter	Value	Meaning
Channel Number	1 - 4	Selected Channel
Mode	0	Enable Reset on Power Up
	1	Disable Reset on Power Up

```
SN60023 > scsiResetDisableSet 1,1
Reset Disable set to TRUE for SCSI 1
will take effect upon reboot
value = 0 = 0x0
SN60023 >
```

scsiShow

The `scsiShow` command displays all SCSI channels and information about the devices attached to each channel. The following example shows the display for a tape library attached to SCSI Channel 2:

```
SN60023 > scsiShow
SCSI Initiator Channel 2: 0xc08d26e0
ID LUN Vendor Product Rev | Sync/Off Width
-----|-----
 0 0 OEM 03570C12 5346 | 25/15 16 S W 0/ 0 8 S W
 0 1 OEM 03570C12 5346 |
 1 0 OEM 03570C12 5346 | 25/15 16 S W 0/ 0 8 S W
value = 0 = 0x0
SN60023 >
```

ID	The SCSI ID of the target device
LUN	The SCSI LUN of the target device
Vendor	The content of the Vendor ID field from the SCSI Inquiry Data
Product	The content of the Product ID field from the SCSI Inquiry Data
Rev	The content of the Revision ID field from the SCSI Inquiry Data
Sync/Off	The negotiated synchronous transfer period and offset. The period is the negotiated transfer period. Multiply the period times 4 nanoseconds

to determine the actual period (exception: if the period is negotiated to 12, then 50ns. is used). The offset indicates the REQ/ACK offset that was negotiated. A zero in these fields indicates that asynchronous transfer is in use.

Width

The negotiated transfer width in bits, either 8 or 16.

scsiTermGet [channel]

The `scsiTermGet` command displays termination status information for the specified channel. If no channel is specified, status information is displayed for all SCSI channels.

```
SN60023 > scsiTermGet
  SCSIbus Termination -----
  SCSI 1 Enabled - default
  SCSI 2 Enabled
  value = 0 = 0x0
SN60023 >
SN60023 > scsiTermGet 2
  SCSIbus Termination -----
  SCSI 2 Enabled - default
  value = 0 = 0x0
SN60023 >
```

scsiTermSet [channel],[termination]

The `scsiTermSet` command enables or disables the termination for the SCSI Channel.

Parameter	Value	Meaning
Channel Number	1 - 4	Selected Channel
Termination	0	Enable Termination
	1	Disable Termination

setFcFrameSize [channel],[size]

Set the frame size for a channel using the `setFcFrameSize` command.

Parameter	Value
SAN Channel Number	1 - 2
Frame Size	512,1024, or 2048

If an invalid size is set, then the frame size of 2048 will be used.

Caution

You must reboot the SNC 5100 after executing this command for the new setting to take effect.

```
SN60023 > setFCFrameSize 1,2048
value = 2048 = 0x800
SN60023 >
```

setFcHardId [channel],[id]

Set the Hard AL_PA for a channel using the setFcHardId command.

Parameter	Value	Meaning
FC Connection Number	1 or 2	
ID Number	0 to 125	
	255	Use Soft ID method

The ID settings 0 to 125, inclusive, are valid IDs. [255] requests the Soft ID method. If an invalid id is requested, then the Soft ID method will be used.

```
SN60023 > setFcHardId 1,1
value = 0 = 0x0
SN60023 >
```

Caution

You must reboot the SNC 5100 after executing this command for the new setting to take effect.

setHost [port],"OS"

The setHost command sets the operating system type for the specified SAN

interface. This provides some customization in the way the SNC 5100 is presented to the particular operating system. If [port] is 0, the change applies to all SAN connections; otherwise the host type is applied to the specified port.

Parameter	Value	
Port	0	Changes will apply to all FC Connections
	1 or 2	Changes will apply to FC Connection 1 or 2, as specified
OS	"nt" "aix" "solaris" "hp-ux" "linux" "netware" "gateway" "generic" "unisys" "as400" "adic snc" "pv-136t-fc" "autosense/nt"	

Caution

You must reboot the SNC 5100 after executing this command for the new setting to take effect.

setNettime [value]

The `setNettime` command enables or disables timeserver functionality.

Value	Meaning
0	Disables timeserver functionality
1	Enables timeserver functionality

```
SN60023 > setNettime 1
Nettime 1 value = 0 = 0x0
```

setSnaCCLun [newLUN]

The `setSnaCCLun` command reassigns the SNC 5100's Command and Control LUN to the specified value.

newLUN is the new value for the Command and Control LUN. Valid values are 0 through 127.

The new setting takes effect immediately. The previous value is removed from the device map and database and a trap is generated indicating that the device was removed.

If the new LUN is not currently in use, a new entry is added in the device map and database. A trap will be generated indicating the new device was added.

If the new LUN is already in use, the Command and Control LUN will be disabled. It will remain disabled until the device mapped at the requested LUN is removed and deleted from the database. In this case, you can use the `mapRebuildDatabase` command to remove the previous LUN assignment and to allow the new Command and Control LUN to be enabled.

Caution

Because AIX and NT use LUN 0 when they issue a Report LUNs command, you must make sure that a device is configured at LUN 0.

setTimeHost

The `setTimeHost` command adds a host running timeserver to the SNC 5100 system. The “`setNettime 1`” command must already have been issued. To add a host named Cronos to the system enter the following command:

```
SN60023 > setTimeHost "Cronos"
Time Host Cronos value = 0 = 0x0
SN60023 >
```

sfmAccessApply

The `sfmAccessApply` command causes the settings that have been changed and stored in memory to take effect immediately and also saves them to the SFM database.

sfmAccessClear [disable code]

The `sfmAccessClear` command disables all host access to all LUNs except to LUN 0 (the Command and Control interface). The disable code is 0xfacade02.

The following command example shows how to disable all access.

```
SN60023 >sfmAccessClear 0xfacade02
value = 0 = 0x0
SN60023 >
```

sfmAccessSet [hostindex],<Starting LUN>,<Ending LUN>,<Access>

The `sfmAccessSet` command sets the access for the specified range of LUNs for the specified host connection index.

Access Value	
0	Disables access to the LUNs
1	Enables access to the LUNs

When you enter this command, the settings are stored in memory but are not applied until you enter the `sfmAccessApply` command. The following example shows how to enable the host at connection index 1 to access LUNs 2 through 32. Existing `hostindex` values can be determined by looking at the “Id” column in the output of the `sfmShow -1` command.

```
SN60023 > sfmAccessSet 1,2,32,1
value = 0 = 0x0
SN60023 >
```

sfmActiveSet

The `sfmActiveSet` command places SFM in the active state. This means that all of the current access settings are put into effect. You would typically only use this command after making SFM inactive. See the `sfmInactiveSet` command.

```
SN60023 > sfmActiveSet
value = 0 = 0x0
```

```
SN60023 >
```

If SFM is already active, the following is displayed.

```
SN60023 > sfmActiveSet
SFM: Already Active
value = 21 = 0x15
SN60023 >
```

sfmConnectionSet [hostindex],“host connection string”

The `sfmConnectionSet` command sets the host connection information for the host at the specified connection index. The connection may be a device name, port address, etc. The following example shows setting the host connection information. Existing `hostindex` values can be determined by looking at the “Id” column in the output of the `sfmShow -1` command.

```
SN60023 > sfmConnectionSet 1,"ScsiPort2[0:0:0] (QLA2100)"
value = 0 = 0x0
SN60023 >
```

sfmFeatureEnable “license key string”

The `sfmFeatureEnable` command enables the SFM feature. Each license key is unique for each Pathlight 5000SNC 5100 serial number. If the feature is factory-enabled you can specify “enable” rather than an actual license key.

sfmHostShow [hostIndex]

The `sfmHostShow` command displays all known Scalar Firewall Manager information for the specified host connection index. The LUN access map is displayed as 16 rows of 16 bytes, one byte for each LUN.

hostIndex is the Id obtained from the `sfmShow` command.

00 in the LUN Access map indicates the host has no access to the LUN.

01 in the LUN Access map indicates the host has access to the LUN.

The following command example shows SFM information for host Id 1.

```
SN60023 > sfmHostShow 1
Host(1):
State = 0, Type = 1, Flags = 0x00000000, Online
WWN: 200000e0:8b0057d8
```

```

Name: 'LABATTS'
Host Type: 'NT 4.0 SP5'
Device Id: 'ScsiPort6 [0:0:0] (QLA2100)
LUN Access:
0: 01 01 01 00 00 00 00 00 00 00 00 00 00 01 01 00
16: 00 00 00 00 00 00 00 00 00 00 01 01 00 00 00 00
32: 00 00 00 00 00 01 01 00 00 00 00 00 00 00 00 00
48: 00 00 00 00 00 00 00 00 00 00 00 00 00 00 00 00
64: 00 00 00 00 00 00 00 00 00 00 00 00 00 00 00 00
80: 00 00 00 00 00 00 00 00 00 00 00 00 00 00 00 00
96: 00 00 00 00 00 00 00 00 00 00 00 00 00 00 00 00
112: 00 00 00 00 00 00 00 00 00 00 00 00 00 00 00 00
128: 00 00 00 00 00 00 00 00 00 00 00 00 00 00 00 00
144: 00 00 00 00 00 00 00 00 00 00 00 00 00 00 00 00
160: 00 00 00 00 00 00 00 00 00 00 00 00 00 00 00 00
176: 00 00 00 00 00 00 00 00 00 00 00 00 00 00 00 00
192: 00 00 00 00 00 00 00 00 00 00 00 00 00 00 00 00
208: 00 00 00 00 00 00 00 00 00 00 00 00 00 00 00 00
224: 00 00 00 00 00 00 00 00 00 00 00 00 00 00 00 00
240: 00 00 00 00 00 00 00 00 00 00 00 00 00 00 00 00
value = 0 = 0x0
SN60023 >

```

sfmInactiveSet

The `sfmInactiveSet` command de-activates SFM making all LUNs available to all host connections. This command typically would be used when troubleshooting a SAN configuration. It removes SFM access control without deleting SFM access settings. Use the `sfmActiveSet` command to re-activate SFM.

```

SN60023 > sfmInactiveSet
value = 0 = 0x0
SN60023 >

```

If SFM is already inactive, the following is displayed.

```

SN60023 > sfmInactiveSet
SFM: Already Inactive
value = 23 = 0x17
SN60023 >

```

sfmNameSet [hostindex], "name string"

The `sfmNameSet` command sets the host name field to the specified “name

string” for the specified host connection index. The following command example shows setting the host name for host Id 1 to “LANDERS”. Existing hostindex and name values can be determined by looking at the “Id” and “Host Name” columns in the output of the `sfmShow -1` command.

```
SN60023 > sfmNameSet 1, "LANDERS"
value = 0 = 0x0
SN60023 >
```

sfmShow [hostIndex]

The `sfmShow` command displays information about hosts that have been registered with Scalar Firewall Manager based on the value of `hostIndex`.

Hostindex	Meaning
-1	Displays brief list of all known host connections
0	Full display of all known host connections, and if online displays a list of all LUNs available to that connection
N (1-48)	Display the full information for the host N only

The following command example shows SFM information for the hosts that have been registered by SFM. Hosts that have the Host Registration Service running with periodic re-registration are shown with a status of Periodic. One of the hosts has more than one Fibre Channel connection to the Pathlight 5000SNC 5100.

```
SN60023 > sfmShow -1
SFM State: Active
Id World Wide Name St. Typ HexFlags Status Host Name Host Type
Host Connection
-----
001 200000e0.8b0057d8 000 001 00000000 Online LANDERS NT 4.0
SP5 ScsiPort6 [0:0:0](QLA2200)
002 200000e0.8b16014d 000 001 00000000 Periodic SUPERIOR NT 4.0
SP5 ScsiPort7 [0:0:0](QLA2200)
003 200000e0.8b160152 000 001 00000000 Offline SUPERIOR NT 4.0
SP5 ScsiPort7 [0:0:0](QLA2200)
value = 0 = 0x0
SN60023 >
```

sfmSparseAccessSet[hostindex],“LUN string”,[Access]

The `sfmSparseAccess` command sets the access for the specified LUNs for the specified host connection index. Same as `sfmAccessSet` except LUNs are entered as a string of characters separated by commas. Existing `hostindex` values can be determined by looking at the “Id” column in the output of the `sfmShow -1` command.

Access	Meaning
0	Disables access to the LUNs
1	enables access to the LUNs

When you enter this command, the settings are stored in memory but are not applied until you enter the `sfmAccessApply` command. The following command example enables host access to the LUNs 1, 2, 3, 4, 6, 9, 22, 23 and 45 on host connection index 1.

```
SN60023 >sfmSparseAccessSet 1,"1,2,3,4,6,9,22,23,45,"1
value = 0 = 0x0
SN60023 >
```

sfmTypeSet [hostIndex],“OS type string”

The `sfmTypeSet` command sets the Operating System type for the specified host connection index. Existing `hostindex` values can be determined by looking at the “Id” column in the output of the `sfmShow -1` command. OS must begin with “NT”, “AIX”, “Linux”, “SOLARIS”, “HP-UX” or “NETWARE”. Additional information may be appended to these strings as desired.

Choosing “Linux” sets the host type default to “Solaris”.

The following command example shows setting the host type to NT 4.0 SP5 for host Id 1.

```
SN60023 > sfmTypeSet 1,"NT 4.0 SP5"
value = 0 = 0x0
SN60023 >
```

shellLock

Only one management interface may be in use at a time. If a network interface is opened, Only one management interface may be in use at a time. If a network

firmware, Power-On-Self-Test (POST), bootrom and Alternate bootrom.

```
SN600726 > showVersions
ADIC Scalar Storage Network Controller Firmware-4
Version 0404.05 Built Oct 19 2001, 14:40:29 on 5xame by jsmyder
  POST          version v040405
  Bootrom       version v040405
  Alt Bootrom   version v040405
value = 0 = 0x0
SN600726 >
```

sncFeatureEnable "licensekeystring"

The `sncFeatureEnable` command enables the optional Data Mover feature. You enable the feature by entering the unique license key.

```
SN60023 > sncFeatureEnable "BVRXC-G79DN"
value = 0 = 0x0
SN60023 >
```

Caution

If the license key was factory-installed, you can enter the word “enable” rather than the actual license key.

```
SN60023 > sncFeatureEnable "enable"
value = 0 = 0x0
Data Mover License is Valid
SN60023 >
```

If `value = 1 = 0x1` message is displayed, it means the license is already installed and Data Mover is already enabled.

If the `value = -1 = 0xffffffff` message is displayed, it means the license is not already installed and you do need to enter the license key.

snmpCommunitiesShow

The `snmpCommunitiesShow` command displays the list of SNMP community strings in use by the SNC 5100.

```
SN60023 > snmpCommunitiesShow

ReadCommunity  ViewIndex
-----
```

```

pub      1
ReadCommunity ViewIndex
-----
public   1
icmp     2

WriteCommunity ViewIndex
-----
priv     1
private  1
TrapCommunity

-----
private
value = 9 = 0x9
SN60023 >

```

SNMP community strings serve to group network devices into logical collections for management purposes. The community string must match on both the ADIC Management Console Server and the SNC 5100 you wish to manage. The default settings do match. Use the ADIC Management Console to view or edit strings that apply to the Server.

For more information, see the *ADIC Management Console User Guide*.

To view or edit strings that apply to the SNC 5100, use the snmp... commands explained below.

snmpHelp

The snmpHelp command displays a list of the snmp commands.

```

SN60023 > snmpHelp

snmpCommunitiesShow
snmpReadCommunityAdd "string"
snmpReadCommunityRemove "string"
snmpTrapCommunitySet "string"
snmpWriteCommunityAdd "string"
snmpWriteCommunityRemove "string"
trapDestAdd "ipaddress"
trapDestRemove "ipaddress"
trapDestShow

```

See User's Guide for more information

```

value = 0 = 0x0
SN60023 >

```

snmpReadCommunityAdd "string",[view]

The `snmpReadCommunityAdd` command adds the specified string to the list of accepted strings for SNMP Read operations (Get and GetNext). The View switch must be set to "1" to be accepted by the ADIC Management Console.

For more information, see the *ADIC Management Console User Guide*.

```
SN60023 > snmpReadCommunityAdd "adic",1
Success
value = 4 = 0x4
SN60023>
```

snmpReadCommunityRemove "string"

The `snmpReadCommunityRemove` command removes the specified string from the list of accepted strings for SNMP Read operations.

```
SN60023 > snmpReadCommunityRemove "adic"
Success
value = 3 = 0x3
SN60023 >
```

snmpTrapCommunitySet "string",[view]

The `snmpTrapCommunitySet` command sets the community string passed with all SNMP traps. The View switch must be set to "1" to be accepted by the ADIC Management Console.

For more information, see the *ADIC Management Console User Guide*.

```
SN60023 > snmpTrapCommunitySet "adic",1
Success
value = 8 = 0x8
SN60023 >
```

snmpWriteCommunityAdd "string",[view]

The `snmpWriteCommunityAdd` command adds the specified string to the list of accepted strings for SNMP Write operations (Set). The View switch must be set to "1" to be accepted by the ADIC Management Console.

For more information, see the *ADIC Management Console User Guide*.

```
SN60023 > snmpWriteCommunityAdd "adic",1
Success
value = 0 = 0x0
SN60023 >
```

snmpWriteCommunityRemove "string"

The `snmpWriteCommunityRemove` command removes the specified string from the list of accepted strings for SNMP Write operations.

```
SN60023 > snmpWriteCommunityRemove "adic"
Success
value = 0 = 0x0
SN60023 >
```

sysConfigShow

The `sysConfigShow` command displays current system parameter settings. The display shows whether or not the SNC 5100's Command and Control interface is enabled or disabled and the LUN that is assigned to it, whether or not enhanced tape performance features are enabled, the MAC address of the Ethernet port; and the SNC 5100's Fibre Channel Node address.

```
SN60023 > sysConfigShow
Current System Parameter Settings:
Command and Control Device (CC) : 0 Enabled
      LUN : 0
Allow Early Write Status for Tape : 1 Enabled
Allow R/W Acceleration for Tape : 1 Enabled
Enet MAC Address: 0.60.45.16.1.4
FC Node WWN: 10000060.45160104
value = 0 = 0x0
SN60023 >
```

sysNodeNameModeSet [Mode]

The `sysNodeNameModeSet` command changes the Fibre Channel Node Name Mode for the Fibre Channel interface ports. In the default mode (Mode 0), each Fibre Channel port on the SNC 5100 has the same node name. For configurations that require the node name to be different, use the `sysNodeNameModeSet` command to change the mode to 1.

An example configuration that requires the Node Name on each Fibre Channel port to be different is where the host has two Host Bus Adapters (HBAs) installed for redundancy. In this configuration, each HBA is connected to a different Fibre Channel port on the SNC 5100. Fail-over software on the host defines one of the HBAs as the primary connection and the other HBA as a spare. If the primary HBA should fail, the fail-over software routes data transfers to the SNC 5100 through the spare HBA.

Mode	Definition
0	Node name is the same on all Fibre Channel interfaces (default)
1	Node name is based on port name but different from port name

If you change the mode, you must reboot the SNC 5100 for new setting to take effect.

See also the `sysNodeNameModeShow` command.

Example:

```
SN60023 > sysNodeNameModeSet 1
Please REBOOT the box to activate your new mode
value = 0 = 0x0
SN60023 >
```

sysNodeNameModeShow

The `sysNodeNameModeShow` command displays the current Fibre Channel Node Name mode. The default mode is 0. See the `sysNodeNameModeSet` command for further information.

Example:

```
SN60023 > sysNodeNameModeShow
Active system node name mode is 0
Mode 0: Node name is the same on all FC Interfaces
Mode 1: Node name is based on port name, but different from port
name
value = 0 = 0x0
SN60023 >
```

sysVpdShow or sysVpdShowAll

The `sysVpdShow` command displays Vital Product data information. The Vital

Product Data for the SNC 5100 includes such items as serial numbers and installed memory sizes, as shown below.

```
SN60023 > sysVpdShow

***** VPD Base Rev. 1 *****

Name      SNC
Mfg       ADIC
OEM       ADIC
Manufacture Date JUN 13 05:19:59 1974
UID       00:00:00:60:45:17:00:17
S/N       600023
Assy HCO   BKA01001P
RID Tag
Firmware ID Firmware-4
FirmwareVend ADIC
Firmware Version 4.01
Config File Sys /nvfs
Code File Sys  /ffs

A Board Name ADIC FCR2
A Board S/N
A Board HCO   BK001120P

B Board Name B Board Proc
B Board S/N
B Board HCO   BK002100P

value = 0 = 0x0
SN60023 >
```

The sysVpdShowAll shows a little more information and includes product

data for the Fibre Channel GBIC.

```
buck172 > sysVpdShowAll
===[ Vital Product Data ]===

***** VPD Base *****

Name      SNC
Mfg       ADIC
OEM       ADIC
Manufacture Date JAN 25 20:39:29 2001
UID       00:00:00:60:45:17:00:0C
S/N       600012
Assy HCO   BKA01001P
RID Tag
Firmware ID Firmware-4
FirmwareVend ADIC
Firmware Version 4.01
Config File Sys /nvfs
Code File Sys  /ffs

***** A BOARD *****

----- Processor Board VPD -----
Name      ADIC FCR2
S/N       00034689
HCO       BK001120P
Flash Megs 8 Meg
Dram Megs 32 Meg
Sys Ram   n/a
NV RAM    512K
CPU       PPC405GP
IO Devices
----- Ethernet VPD -----
IO Class   Fixed IO
IO Type    Ether
IO Mfg     IBM
Device Index 01
IO Class Enum n/a
IO Type Enum n/a
Label Index 02
Bus Id     n/a12
----- FC 1 VPD -----
IO Class   Fixed IO
IO Type    Fibre Channel
IO Mfg     QLogic
```

```
Device Index 02
IO Class Enum n/a
IO Type Enum n/a
Label Index 02
Bus Id 0.7.0
----- FC 2 VPD -----
IO Class Fixed IO
IO Type Fibre Channel
IO Mfg QLogic
Device Index 03
IO Class Enum n/a
IO Type Enum n/a
Label Index 02
Bus Id 0.8.0
----- IO Option Card VPD -----
IO Class Option IO
IO Type GBIC
IO Mfg unknown
S/N unknown
HCO none
Device Index 04
IO Class Enum n/a
IO Type Enum n/a
Slot Index 1
Bus Id n/a12
Device Data unknown

----- IO Option Card VPD -----
IO Class Option IO
IO Type GBIC
IO Mfg unknown
S/N unknown
HCO none
Device Index 05
IO Class Enum n/a
IO Type Enum n/a
Slot Index 2
Bus Id n/a12
Device Data unknown

----- RS232 VPD -----
IO Class RS232
IO Type RS232
IO Mfg unknown
S/N n/a
HCO n/a
Device Index 06
IO Class Enum n/a
```

```
IO Type Enum n/a
Baud 19200
Flow Hardware
----- RS232 VPD -----
IO Class RS232
IO Type RS232
IO Mfg unknown
S/N n/a
HCO n/a
Device Index 07
IO Class Enum n/a
IO Type Enum n/a
Baud unknown
Flow unknown
```

```
***** B BOARD *****
```

```
----- Processor Board VPD -----
Name B Board Proc
S/N 00032601
HCO BK002100P
Flash Megs none
Dram Megs 128 Meg
Sys Ram
NV RAM
CPU 80303
IO Devices
----- SCSI 1 VPD -----
IO Class Fixed IO
IO Type SCSI
IO Mfg LSI Logic
Device Index 08
IO Class Enum n/a
IO Type Enum n/a
Label Index 03
Bus Id 1.0.0
----- SCSI 2 VPD -----
IO Class Fixed IO
IO Type SCSI
IO Mfg LSI Logic
Device Index 09
IO Class Enum n/a
IO Type Enum n/a
Label Index 03
Bus Id 1.0.1
----- SCSI 3 VPD -----
IO Class Fixed IO
IO Type SCSI
IO Mfg LSI Logic
```

```

Device Index 10
IO Class Enum n/a
IO Type Enum n/a
Label Index 03
Bus Id 1.1.0
----- SCSI 4 VPD -----
IO Class Fixed IO
IO Type SCSI
IO Mfg LSI Logic
Device Index 11
IO Class Enum n/a
IO Type Enum n/a
Label Index 03
Bus Id 1.1.1
value = 0 = 0x0
buck172 >

```

sz "filename"

The `sz` command initiates a send Zmodem file transfer session. You use this command when you want to save configuration information to a file in case the SNC 5100 needs to be replaced. The SNC 5100 uses Zmodem protocol to upload its persistent address map database and configuration parameter settings from its nonvolatile flash memory to a file on the service terminal. After issuing this command, you start the file transfer from the service terminal by initiating a receive file operation that uses Zmodem protocol.

The filename "config.cfg" is shown in the example below. You can specify a different name for the file but the name must not exceed 8 characters and it must end in .cfg. See also the `rz` command for information about receiving a configuration file.

```

SN60023 > sz "config.cfg"
Configuration Download Complete: config.cfg
value = 0 = 0x0
SN60023 >

```

targets

The SNC 5100 maintains a list of target devices that are attached to the I/O channels. The `targets` command will list each device currently attached, providing descriptions of the devices.

```

SN60023 > targets

```

```

Idx Tdev  Vendor Product  Rev | Type Specific
-----|-----
0 0xc194a400 ADIC Local 0252 | Cmd/Cntrl Status 0h
2 0xc1ffc390 ADIC 5324 | Tape: Blk Size 32768 , flags 7h
3 0xc1ffc290 ADIC 5324 | Changer: flags 7h
value = 4 = 0x4
SN60023 >

```

IdxDevice Index in the target list.

TdevAn internal pointer, used for some diagnostic operations

VendorThe content of the Vendor ID field from the SCSI Inquiry Data

ProductThe content of the Product ID field from the SCSI Inquiry Data

RevThe content of the Revision ID field from the SCSI Inquiry Data

Type SpecificFor each device type, information pertinent to the device

tcpstatShow

The `tcpstatShow` command displays TCP statistics for the Ethernet network. Interpreting these statistics requires detailed knowledge of Internet networking protocols. This information may be useful to the LAN administrator.

```

SN60023 > tcpstatShow
TCP:
  301 packets sent
    278 data packets (18371 bytes)
    0 data packet (0 byte) retransmitted
    23 ack-only packets (22 delayed)
    0 URG only packet
    0 window probe packet
    0 window update packet
    0 control packet
  516 packets received
    272 acks (for 18372 bytes)
    1 duplicate ack
    0 ack for unsend data
    276 packets (322 bytes) received in-sequence
    0 completely duplicate packet (0 byte)
    0 packet with some dup. data (0 byte duped)
    0 out-of-order packet (0 byte)
    0 packet (0 byte) of data after window
    0 window probe
    0 window update packet
    0 packet received after close
    0 discarded for bad checksum

```

```

0 discarded for bad header offset field
0 discarded because packet too short
0 connection request
1 connection accept
1 connection established (including accepts)
1 connection closed (including 0 drop)
0 embryonic connection dropped
272 segments updated rtt (of 272 attempts)
0 retransmit timeout
0 connection dropped by rexmit timeout
0 persist timeout
1 keepalive timeout
1 keepalive probe sent
0 connection dropped by keepalive
value = 36 = 0x24 = '$
SN60023 >

```

trapDestAdd "ipAddress"

The `trapDestAdd` command allows you to add an ethernet address as a trap recipient to the SNMP trap destination table that is maintained within the SNC 5100. The broadcast address for the Ethernet port is also automatically included in the table. When the ADIC Management Console is running, it inserts its address into the table automatically.

For more information, see the *ADIC Management Console User Guide*.

```

SN60023 > trapDestAdd 192.168.1.75
value = 0 = 0x0
SN60023 >

```

trapDestRemove "ipAddress"

The `trapDestRemove` command allows you to remove an ethernet address as a trap recipient from the SNMP trap destination table that is maintained within the SNC 5100. When the ADIC Management Console is running, it inserts its address into the table automatically.

For more information, see the *ADIC Management Console User Guide*.

The broadcast address for the Ethernet port is also automatically included in the table

```

SN60023 > trapDestRemove "10.0.0.2"
value = 0 = 0x0
SN60023 >

```

trapDestShow

The `trapDestShow` command allows you to view the SNMP trap destination table maintained within the SNC 5100. The broadcast address for the Ethernet port is also automatically included in the table. When the ADIC Management Console is running, it inserts its address into the table automatically.

For more information, see the *ADIC Management Console User Guide*.

```
SN60023 > trapDestShow
Trap Destination IP Address
-----
192.168.30.255
206.0.64.17
206.0.64.25
206.0.64.35
206.0.64.255
value = 1 = 0x1
SN60023 >
```

tzSet "timezone"

The `tzSet` command sets the timezone offset from Greenwich Mean Time.

```
SN60023 > tzSet "PDT"
TZ Set TIMEZONE
value = 0 = 0x0
SN60023 >
```

udpstatShow

The `udpstatShow` command displays UDP statistics for the Ethernet network. Interpreting these statistics requires detailed knowledge of Internet networking protocols. This information may be useful to the LAN administrator.

```
SN60023 > udpstatShow
UDP:
8514 total packets
8445 input packets
69 output packets
0 incomplete header
0 bad data length field
0 bad checksum
8383 broadcasts received with no ports
0 full socket
```

```
value = 15 = 0xf
SN60023C >
```

uptime

The `uptime` command displays the elapsed time since the last boot of the SNC 5100.

```
SN60023 > uptime
Elapsed time since reset 4d:23h:12m:46s:10t
value = 10 = 0xa
SN60023 >
```

The example indicates that 4 days, 23 hours, 12 minutes, 46 seconds and 10 clock ticks have elapsed since the SNC 5100 was last booted. There are 60 ticks per second.

user

The `userAdd`, `userDelete`, and `userList` commands provide control of the user list. The persistent address map file can be sent to the SNC 5100 or retrieved from it using FTP. If you need to use FTP, use the user commands to create a login and password so you can access the SNC 5100 from the Ethernet network.

userAdd "username", "password"

The `userAdd` command adds a user and password to the password file. The parameter "username" must be from 3 to 80 characters. The parameter "password" must be from 8 to 40 characters.

```
SN60023 > userAdd "nancy", "password"
value = 0 = 0x0
SN60023 >
```

userDelete "username", "password"

The `userDelete` command deletes a user from the password file. It is not possible to remove a user without knowing the user's password. If the user's password is forgotten or unknown, you have to delete the password file, reboot the SNC 5100, and then add all user names and passwords again.

```
SN60023 > userDelete "nancy", "password"
```

```
value = 0 = 0x0
SN60023 >
```

userList

The `userList` command displays the contents of the password file (passwords are encrypted).

```
SN60023 > userList
Name : Password
nancy : SyecycRz
fred : b9dczebQbd
martha : RQQdRedb9d
user : cScQRSQzzz
value = 0 = 0x0
SN60023 >
```

userHelp

The `userHelp` command displays a list of the user commands.

```
SN60023 > userHelp

userAdd "name","password" - Add user to user list
userDelete "name","password" - Delete user from user list
userList          - Display user list

See User's Guide for more information

value = 0 = 0x0
SN60023>
```

version

The SNC 5100 is an intelligent device and has software that controls all functions. The revision of that operating software can be displayed with the `version` command. The first line displayed is the SNC 5100 firmware version. The lines that follow pertain to the operating system software version.

```
SN600033 > version

ADIC Firmware-4
Version 0401.0701 Built Mar 2 2001, 10:55:47 on EDELWEISS by
```

```
terryk  
VxWorks (for Buckhorn - IBM PowerPC 405GP Rev. D) version 5.4.  
Kernel: WIND version 2.5.  
value = 26 = 0x1a  
SN600033 >
```

Diagnostic Command Reference

This section specifies the procedures used when diagnostics are required.

Boot Modes

The SNC 5100 has two modes of operation: `normal` mode and `diagmode`. Two commands are available from the service terminal to reboot the SNC 5100 to the desired mode. The SNC 5100 remains in the existing mode until it has been directed to reboot in the other mode.

When the SNC 5100 is booted in `diagmode`, the command prompt displayed on the service terminal is `diagmode >`. While in `diagmode`, a limited command set is available for testing the SNC 5100 interfaces. In addition, the device drivers for the Ethernet, Fibre Channel, and SCSI interfaces are disabled so loop back tests can be performed on them.

Entering Diagnostic Mode

Use the `diagBoot` command when the special features of the SNC 5100's diagnostic module are required.

Follow this procedure to enter diagnostic mode.

Step 1. Stop all I/O.

Caution

Before entering `diagmode`, you must disconnect all SCSI and FC cables from the SNC 5100. If you do not, the data on the attached tape devices will become corrupted.

Step 2. Shut down the SNC 5100.

Step 3. Remove the Ethernet cable, if installed.

Step 4. Connect the terminal to the Service Port.

Step 5. Turn on the SNC 5100 and wait for it to finish booting.

Step 6. If the command prompt displayed on the service terminal is `diagmode >`, proceed with the appropriate diagnostic tests.

If the command prompt displayed on the service terminal is not `diagmode >`, enter the `diagBoot` command.

- Step 7.** Wait for the SNC 5100 to reboot.
- Step 8.** At the `diagmode >` prompt, proceed with the appropriate diagnostic tests.

Restoring Normal Mode

Follow this procedure if the SNC 5100 was placed in diagnostic mode and needs to be restored to normal operation.

- Step 1.** Connect the terminal to the Service Port, if it is not already connected.
- Step 2.** If it is not already on, turn on the SNC 5100 and wait for it to finish booting.
- Step 3.** From the service terminal, type the `normalBoot` command.
- Step 4.** Wait for the SNC 5100 to reboot.
- Step 5.** At the command prompt, continue with the MAP that sent you here.

Special Procedures

This section contains information on special procedures.

Health Check

The Health Check function provides a method to periodically determine the operational state of an SNC 5100 and its attached interfaces and devices.

Manual Health Check

Health Check is performed manually from the service terminal **only** if the SNC 5100 is in normal mode.

See “Perform Health Check” on page 46, for instructions.

Event Log Dump

The events that have been logged in the SNC 5100's Event Log can be displayed on the service terminal or viewed from the ADIC Management Console.

For more information, see the *ADIC Management Console User Guide*.

This information may be useful because you can see the normal events and any abnormal events that may lead you to the source of an internal or external failure.

Each entry contains a sequence number, day, and time-stamp, the event code, event source (interface name or system process), an index, and a description of the event.

If the Real Time Clock has been set, the time-stamp will be real time. Otherwise, the time stamp will be relative to the boot-time.

The Event Log holds more than 2000 events. When the log becomes full, the oldest events are overwritten by the most recent events.

You can choose to view only those events logged since the SNC 5100 was last booted or you can view a longer list of events that have accumulated from previous boots.

You can choose to view events by severity level. Selecting **Warning** will display **Warning** and **Notice** events. Selecting **Information** will display **Information**, **Warning** and **Notice** events.

See the "loggerDump [number]" command on page 141 or the "loggerDumpCurrent [level]" command on page 142.

See also Figure 6 on page 35, "Detail of Event Log Listing From Service Port."

Retrieving the Code 43 Dump File

If an event code 43 was reported to the ADIC Management Console client, it is an indication that the SNC 5100 performed an error recovery operation and had to reset the Fibre Channel interface to clear a lock-up condition.

For more information, see the *ADIC Management Console User Guide*.

This event is also recorded in the SNC 5100 event log along with the name of a file that was saved to the flash file system. The file contains information about the state of the Fibre Channel interface prior to the reset.

Follow these steps to retrieve the file.

Step 1. Connect the service terminal to the Service Port.

For more information, see “Connecting to the Service Port” on page 95.

Step 2. Press the **Enter** key on the service terminal.

If the prompt is not displayed, go to “Service Port MAP” on page 75.

Step 3. From the service terminal, navigate to the “DUMP” directory by entering the `cd “/ffs/dump”` command.

Step 4. From the service terminal, enter the `ls` command to get a file listing for the directory.

There may be more than one file present if the error condition has occurred more than once.

Caution

Dump file names end in `.dmp` and the files are automatically deleted whenever you update the SNC 5100’s firmware.

Step 5. Refer to the section “Saving a Configuration File” on page 99.

Substitute the name of the dump file and use that procedure to save the file to the service terminal.

Repeat this step if there is more than one file.

Save each file to the service terminal.

Step 6. Send the file to `support@adic.com` for analysis, attaching the dump file to the message.

Boot Mode Commands

diagBoot

This command is used only to transition an SNC 5100 from normal operations to the special diagnostic mode.

Caution

All SCSI and FC cables must be disconnected before entering the `diagBoot` command.

- The `diagBoot` command first ensures that the `/nvfs:mt` directory exists.
- It copies the existing bootline to a file in the `/nvfs:mt` directory on the SNC 5100.
- It installs a new bootline directing the SNC 5100 to boot using a special diagnostic startup script `/ffs:mt/diagnstk.rc`.
- It renames the persistent map file `config/device.map` as `config/device.bak` (a new file will be generated after rebooting).
- It issues a `reboot` command to put the changes into effect.

normalBoot

The `normalBoot` command is used only to transition the SNC 5100 from the special diagnostic mode to resume normal operation.

- It restores the bootline that was copied by `diagBoot`.
- It erases the new persistent device map and renames the original map file `config/device.map` – restoring it for use when the SNC 5100 reboots.
- It reboots the SNC 5100.

Diagnostic Commands

This section is a reference for the commands that are available when the SNC 5100 is booted in `diagmode`.

The command set is limited while in `diagmode`. You will need to use the `showBox` command and three commands (with the suffix `Test`) when testing the Ethernet, Fibre Channel, and SCSI interfaces.

The Ethernet loop back plug, Fibre Channel loop back plug, and SCSI cable provided in the Service Tool Kit are required for the corresponding loop back test.

Caution

You must disconnect the FC and SCSI cables from the SNC 5100. If you do not, the data on the attached tape devices will become corrupted.

elTest

elTest is the Ethernet loop back test. The SNC 5100 must be in diagnostic mode to use this command and a loop back plug must be installed on the Ethernet port.

```
diagmode > elTest
==== Testing Ethernet ====
Init complete.
Ethernet OK
value = 0 = 0x0
```

The test issues a series of loop back tests. Test data is transferred and verified. A good test ends with Ethernet OK.

If errors are detected, the test displays the number of bad test iterations as shown below. If your test was not successful, return to the MAP that sent you here.

```
diagmode > elTest
==== Testing Ethernet ====
Init complete.
Ethernet timeout error
Ethernet timeout error
Ethernet timeout error
Ethernet timeout error
Ethernet timeout error
Ethernet timeout error
Ethernet test reported 6 errors out of 12 iterations
value = 6 = 0x6
```

fcSlotTest [x]

The SNC 5100 must be in diagnostic mode to use this command and a loop back plug must be connected to the GBIC.

The `fcSlotTest` command performs a confidence test on a Fibre Channel slot. Substitute for `x` the Fibre Channel slot number you want to test. This command can be used to test the slot or the cable.

The following example code shows the display for a test Fibre Channel slot 1.

```
diagmode > fcSlotTest 1
FC 1 [#####] Iterations 72 Errors 0 - PASSED
Fibre Channel Port 1 returns PASSED
value = 0 = 0x0
diagmode > fcSlotTest 2
FC 1 [#####] Iterations 72 Errors 0 - PASSED
Fibre Channel Port 2 returns PASSED
value = 0 = 0x0
```

The following outputs are examples Fibre Channel port tests that were not successful. If your test was not successful, return to the MAP that sent you here.

Unsuccessful Fibre Test 1:

```
diagmode > fcSlotTest 1
FC 1 [#####] Iterations 7799 Errors 7799 - FAILED
Fibre Channel Port 1 returns FAILED
value = -1 = 0xffffffff = pNullDmaDesc + 0xfe4ea9f7
```

Note: If the Fibre Channel “link” LED does not come on, the test will not pass.

Unsuccessful Fibre Test 2 (cable not plugged in):

```
diagmode > fcSlotTest 1
FC 1 [#####] Iterations 37 Errors 37 - FAILED
Fibre Channel Port 1 returns FAILED
value = -1 = 0xffffffff = pNullDmaDesc + 0xfe4ea9f7
```

scsiChannelTest (x,y)

The SNC 5100 must be in diagnostic mode to use this command and a SCSI cable must be connected between two SCSI channels.

The `scsiChannelTest` command performs a confidence test on a pair of SCSI channels. Substitute for `x` and `y` the SCSI channel numbers you want to test. Parentheses are optional. This command can be used to test the SCSI interface or the SCSI cable.

The example below shows the display for a test on SCSI channels 1 and 2.

```
diagmode > scsiChannelTest (3,4)
SCSI-3 -> SCSI-4 [#####] 10 iterations PASSED
SCSI-4 -> SCSI-3 [#####] 10 iterations PASSED
value = 0 = 0x0
diagmode > scsiChannelTest (1,2)
SCSI-1 -> SCSI-2 [#####] 10 iterations PASSED
SCSI-2 -> SCSI-1 [#####] 10 iterations PASSED
value = 0 = 0x0
```

The following output is an example of a SCSI port test that was not successful. If your test was not successful, return to the MAP that sent you here.

Unsuccessful SCSI Test (cable not plugged in):

```
diagmode > scsiChannelTest (1,2)
SCSI Initiator Error(s) - STO iUnk
SCSI Initiator Error(s) - STO iUnk
SCSI-1 -> SCSI-2 [SCSI Initiator Error(s) - STO iUnk
  ERROR, i = 1 ] 1 iterations FAILURE
SCSI-2 -> SCSI-1 [SCSI Initiator Error(s) - STO iUnk
  ERROR, i = 1 ] 1 iterations FAILURE
value = -1 = 0xffffffff = pNullDmaDesc + 0xfe4ea9f7
```

showBox

The `showBox` command displays the components present in the SNC 5100 using characters to form a picture of the unit, as viewed from the rear.

showBox also lists the cabling requirements for each slot:

```
SN60023 > showBox
```

```
Back
```

```

/-----/
/-----/
/-----/
/-----/
|          FC1          FC2          |
|        [SW-2]        [SW-2]        |
|
| [LVDT] [LVDT] [LVDT] [LVDT] |
| SCSI1  SCSI2  SCSI3  SCSI4 |
|-----|-----|-----|-----|
|/ Front
```

LVDT = SCSI Low Voltage Differential - Terminated
SW-2 = Short Wave - Two GB

```
value = 0 = 0x0
```

```
SN60023 >
```

supportDump

The `supportDump` command outputs the result of a number of Service Port commands in a standard way and in a specific order. The resulting file is used for troubleshooting. The individual commands called by `supportDump` are:

```

envShow
version
showBox
sysVpdShowAll
sysConfigShow
licenseShow
sfmShow
hostTypeShow
targets
scsiShow
fcShow 2
fcShowDevs
mapShowDevs
mapShowDatabase
showScsiAssign
fctShowChan 1
fctShowChan 2
cleShowAll
loggerDumpCurrent
```

```
envMonShow  
dmva  
reserveShow 1
```

POST Error Codes

The Power-On-Self-Test (POST) is responsible for testing the integrity of the processor's SDRAM. After testing SDRAM POST will attempt to transfer control to either the default bootrom image or an alternate image.

POST can also download binary images over the service port and write them to flash memory. This enables POST to perform a minimal amount of emergency recovery from FLASH errors.

POST Boot Behavior

ROM Init

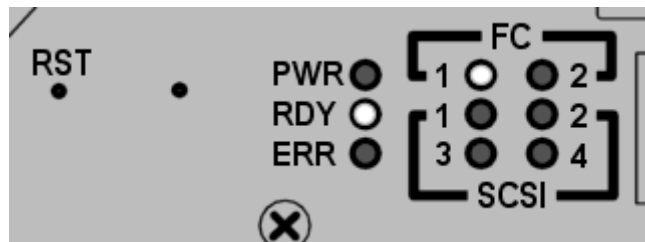

Figure 10 ROM Init

After applying power the **ERR** LED will illuminate.

At this time `postInit` code initializes the processor's internal registers and subsystems, including the SDRAM controller.

The processor's internal RAM is used as a tiny-stack for this stage of POST.

Control is then passed to the `IpostMain` routine for the SDRAM memory.

Initial POST

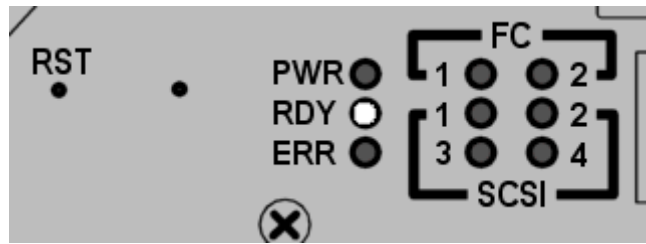

Figure 11 Initial POST

`IpostMain` starts by initializing the service-port and the system PLD(s). The **ERR** LED will extinguish and the **RDY** LED will turn on. POST will display the following message on the service port:

```
== POST Version nnn ==
```

Simple Access Test

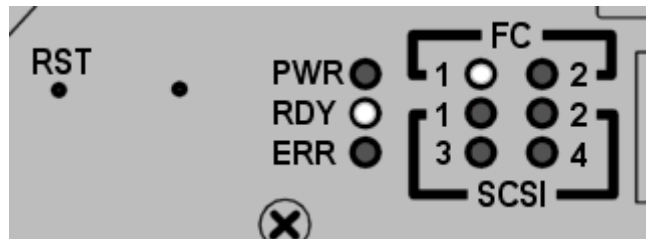

Figure 12 Simple Access

The simple access test verifies that the processor can perform basic writes and reads to the SDRAM. This test is identified by the flash of the **FC1** LED.

Bitwalk Test

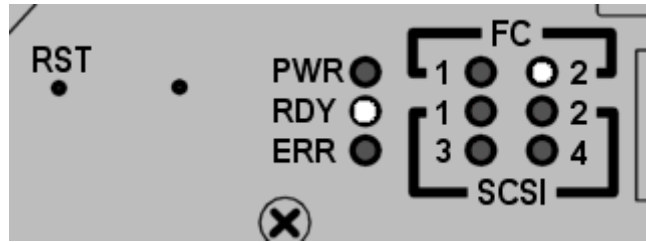

Figure 13 Bitwalk Test

This test first walks a one-bit then a zero-bit through the base of each bank of SDRAM. This test is identified by the flash of the **FC2** LED.

Memory Size

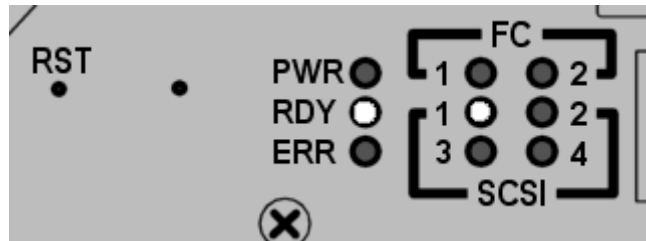

Figure 14 Memory Size

This test verifies that the apparent size of SDRAM meets the minimum and maximum sizes specified for the product. This test is identified by the flash of the **SCSI1** LED.

Pattern Test

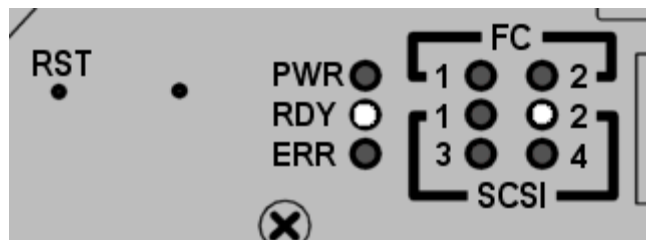

Figure 15 Pattern Test

This test writes and reads a series of diagnostic patterns to each memory location in SDRAM. This test is identified by the repeated flash of the **SCSI2** LED. This test can take several seconds to complete.

Address Test

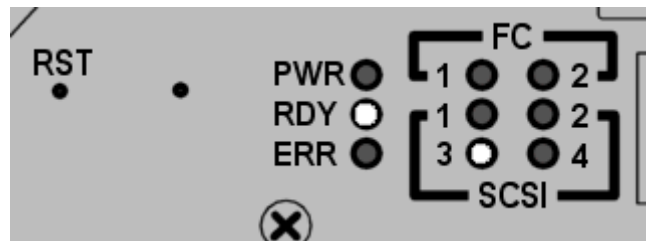

Figure 16 Address Test

This test writes and reads address tags to memory to test for bad SDRAM address lines. This test is identified by the flash of the **SCSI3** LED. POST then relocates itself to SDRAM and moves its stack from processor internal RAM to SDRAM. Control is then transferred to the SDRAM based Secondary POST.

Secondary POST

This stage of POST attempts to locate and execute the intermediate loader, or “bootrom”. If the operator presses the interrupt button then POST will enter into the service menu. See the section “POST Service Menu” for details.

Identify and Execute bootrom

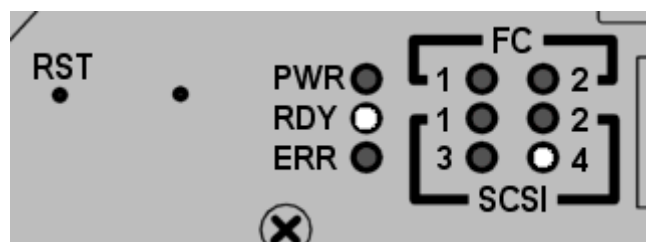

Figure 17 Identify and Execute

POST will examine the FLASH memory primary bootrom locations to determine whether or not it contains a viable bootrom. If the bootrom appears valid then POST will transfer control to it. If the bootrom image is considered invalid then POST will repeat the bootrom checks at the location of the secondary bootrom. This step is indicated by the flash of the **SCSI4** LED.

Start of Bootrom

When POST starts a bootrom image it will display a line like:

```
Bootrom (*FFF00100)(2)
```

The number in the first parenthesis is the address of the bootrom's startup code. The number in the second parenthesis is flag to the operating system to determine what type of boot it has – warm or cold.

Bootrom code will set the **ERR** LED when it reconfigures the PLD.

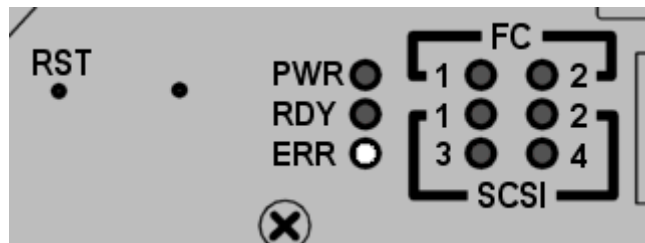

Figure 18 Start of bootrom

POST Service Menu

The POST Service Menu is enabled by using a slim tool, for example, an unfolded paper clip, to depress the unlabeled button between the **RST** button and **PWR** LED.

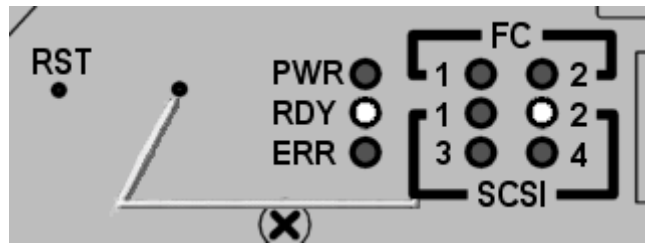

Figure 19 NMI 1

The button may be depressed any time during the memory tests.

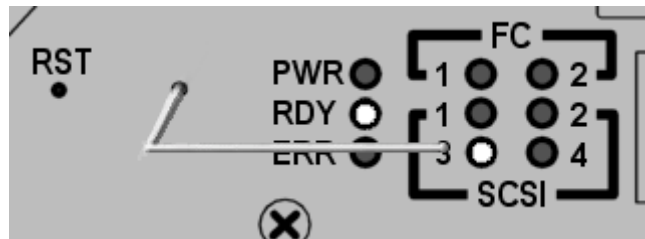

Figure 20 NMI 2

After completing the memory tests POST will display:

```
== POST Version nnn ==
```

```
== POST MENU ==
```

```
A - Cold boot from [A]lternate bootrom
B - Cold [B]oot from primary bootrom
R - [R]eceive new boot image from serial port
V - full [V]ersion information
```

A - Cold boot from [A]lternate bootrom

This option causes POST to transfer control to the alternate bootrom image at address 0xFFE00100 and to treat it as a cold boot. Unless you are instructed to boot from the Alternate bootrom by service personnel, you should boot from option B, below.

B - Cold [B]oot from primary bootrom

This option causes POST to transfer control to the default, or primary, bootrom image at address 0xFFF00100 and to treat it as a cold boot. After loading in a new bootrom image, select this option to boot the SNC 5100

R - [R]eceive new boot image from serial port

This will start the ZMODEM transfer engine that transfers a single binary bootrom image file to POST using the service port. It should not be used to receive other kinds of binary image files. If the transfer is successful then POST will program the bootrom image into the FLASH memory device.

While waiting for the file, POST will display:

```
**B000000023be50
```

At this point the operator may transfer the bootrom “.bin” file to POST using the ZMODEM protocol. Refer to terminal emulator documentation for details on how to do this. After the file is transferred, POST will display:

```
File transfer and update PASSED
```

```
ZMODEM Messages:
```

```
Writing to flash:MMMMMMMM-NNNN
```

MMMMMMMM is the address that is being written in FLASH memory and NNNN is the length of the image. At this point the operator should choose option “B”, Cold [B]oot from primary bootrom.” If errors are encountered, POST will display appropriate messages along with the line:

```
File transfer and update FAILED
```

V- full [V]ersion information

This command will cause POST to display its version number, build date, the machine it was built on, and the user who built it. The display will look like:

```
POST version 0402.02 Built Apr 4 2001, 15:24:06 on TANGLEFOOT by jim
```

Error Displays

POST will flash the **ERR** LED along with the LEDs associated with any failed test. Refer to the LED assignments in the normal POST sequence. Error messages may also be displayed on the service port.

Startup Message Reference

After the SNC 5100 completes its power-on self-test, it will attempt to find, load, and run the real-time LIC boot loader.

Bootrom Messages

See the sample code below.

```
Press any key to stop auto-boot...
0
auto-booting...

boot device      : ibmEmac
unit number     : 0
processor number : 0
file name       : //ffs/vxWorks.st
inet on ethernet (e) : 192.168.1.183
flags (f)       : 0x8
target name (tn) : SN600030
startup script (s) : //ffs/sna.rc

Attaching to TFFS... done.
Loading /ffs/vxWorks.st...2697865
Done
Starting at 0x10000...
```

LIC Initialization Messages

After the BootLoader finds and loads the licensed internal code (LIC), the BootLoader will transfer control and start SNC 5100 operations. See the sample code below.

```
Host Name: bootHost
User: buckhorn
Attached TCP/IP interface to ibmEmac unit 0
Attaching network interface lo0... done.
NFS client support not included.
Adding 8123 symbols for standalone.
SDRAM DIMM: 128 Meg - 1 banks detected
Enabling MMU Data Translation
```

```
Firmware-4
Version 0401.5 Built Feb 1 2001, 17:23:51 on redsky for Buckhorn
- IBM PowerPC 405GP Rev. D
Product Type - ADIC FCR2
Copyright ADIC, 1994-2001
```

```
VxWorks 5.4 WIND version 2.5BSP 1.2/4a
Copyright Wind River Systems, Inc., 1984-2000
```

```
Memory Size: 0x2000000
```

```
/nvfs/ - disk check in progress ...
/nvfs/ - Volume is OK
    total # of clusters: 1,008
    # of free clusters: 935
    # of bad clusters: 0
    total free space: 478,720
    max contiguous free space: 478,720 bytes
    # of files: 5
    # of folders: 10
    total bytes in files: 29,785
    # of lost chains: 0
    total bytes in lost chains: 0
Executing startup script /ffs/sna.rc ...
#! /bin/csh -f
CNFinit
value = 0 = 0x0
```

```
csSrvcInit
SN600030
Clock set from RTC
value = 0 = 0x0
amemInit
SDRAM DIMM: 128 Meg - 1 banks detected
value = 0 = 0x0
appInit
```

Final Startup Messages

In the final stage of the boot process, information is displayed about the firmware version, SNC 5100 name, optional features that are enabled or disabled, SCSI Channels, and the IP address. In the example below, after the SNC 5100 command prompt, a message is displayed as a result of a response from a host that is running the Host Registration Service for Scalar Firewall Manager access control.

```
SFM Disabled, License is Invalid
Data Mover Enabled, License is Valid
SAN Management Disabled, License is Invalid
VPM Disabled, License is Invalid
USCSI 4 - LVD Term Enabled
USCSI 3 - LVD Term Enabled
USCSI 2 - LVD Term Enabled
USCSI 1 - LVD Term Enabled
SN600030
value = 28051936 = 0x1ac09e0
Done executing startup script /ffs/sna.rc
SN600030 >
```

Glossary

Acronyms

BIOS	Basic Input/Output System
DE	Differential Ended
DRAM	Dynamic Random Access Memory
DTE	Data Terminal Equipment
ESD	Electrostatic Discharge
EMI	Electromagnetic Interference
GUI	Graphical User Interface
HBA	Host Bus Adapter
HSM	Hierarchical Storage Management
HTTP	Hypertext Transfer Protocol
I/O	Input/Output
IP	Internet Protocol
JMAPI	Java Management Application Programming Interface
JRE	Java RunTime Environment
LED	Light Emitting Diode
LUN	Logical Unit Number
LVD	Low Voltage Differential
LW	Long Wavelength
MAP	Maintenance Action Plan
MIB	Management Information Base
MTBF	Mean Time Between Failures

POST	Power-On Self test
PPP	Point-to-Point Protocol
RFI	Radio Frequency Interference
RID	Replacement Identification
RMI	Remote Method Invocation
RPC	Remote Procedure Call
RTOS	Real Time Operating System
SAN	Storage Area Network
SCSI	Small Computer System Interface
SDRAM	Synchronous Dynamic Random Access Memory
SE	Single-Ended
SFM	Scalar Firewall Manager
SNMP	Simple Network Management Protocol
SRS	SAN Replication Services
TCP	Transmission Control Protocol
VDC	Volts Direct Current

Warranty and EULA

ADIC Limited Product Warranty

1. Subject to the limitations set forth below, ADIC warrants to Buyer as follows:
 - b.) For 3 years from the date of delivery to Buyer, all hardware products manufactured by ADIC (hereafter Products), excluding drives and media manufactured by third parties, which are covered by paragraph (c) below, will be capable of performing substantially in accordance with the applicable specifications for such Products stated in documentation supplied by ADIC;
 - c.) All hardware repairs made by ADIC will be free from defects in material and workmanship for the greater of the original warranty period or 3 months from the date such repairs are made; and
 - d.) With respect to drives, tapes, and software manufactured by a third party, which are supplied by ADIC, Buyer will be the beneficiary of the manufacturer's warranties, if any, **SUBJECT TO THE LIMITATIONS STATED THEREIN**. Copies of such manufacturer's warranties will be made available to Buyer upon request. **ADIC DISCLAIMS AND EXCLUDES ALL WARRANTIES WITH RESPECT TO SUCH ITEMS.**
2. The foregoing warranties will be voided if the Products are not properly installed, serviced, used, or maintained according to ADIC's printed instructions or if the Products have been damaged or modified after delivery. Buyer assumes responsibility for the selection of the Products for the uses for which they are purchased.
3. If a defect is found and reported to ADIC in writing within the warranty period, ADIC will, in its sole discretion and as its sole responsibility and liability and as **BUYER'S SOLE AND EXCLUSIVE REMEDY** for breach of warranty, either repair or replace the nonconforming Product or accept the return thereof and refund to Buyer the price paid to ADIC for such nonconforming Product. ADIC will respond to Buyer's request for return material authorization within 72 hours of Buyer's notice. All warranty repair work or inspections must be performed at an ADIC facility designated by ADIC. Shipment to ADIC's facility and all risk of loss or damage during shipment shall be borne by, or for the account of, Buyer.

4. ADIC will indemnify Buyer for any damages and costs finally awarded against Buyer on the grounds that the Products, in the form and condition delivered by ADIC to Buyer hereunder, infringe on any valid United States patents or copyrights of any third party, provided that Buyer notifies ADIC in writing of any such claim within 10 days after learning thereof and that Buyer gives ADIC full control over the defense and settlement of the claim and fully cooperates with ADIC with respect thereto. If any such claim is brought or is likely to be brought, ADIC may at its option replace or modify the Products to make them non-infringing, or refund to Buyer, upon the return of the Products at issue, the price paid therefore, less 20% for each year which has passed since the date of delivery hereunder. Buyer must discontinue all use of any portion of the Products that has been replaced or modified or for which such a refund has been tendered. ADIC's obligation hereunder will not apply to any claim based on ADIC's following Buyer's or its customers' specifications or requests, the use of the Products to practice a process or in conjunction with items not supplied by ADIC, and Buyer will similarly indemnify ADIC with respect to any such claims. **THE FOREGOING STATES ADIC'S SOLE RESPONSIBILITY, AND BUYER'S SOLE REMEDY, FOR ANY INFRINGEMENTS OF ANY PROPRIETARY RIGHTS.**
5. **ADIC DOES NOT WARRANT THAT THE PRODUCTS WILL MEET ALL END-USER REQUIREMENTS OR THAT OPERATION OF THE PRODUCTS WILL BE UNINTERRUPTED OR TROUBLE FREE. THE WARRANTIES SET FORTH ABOVE ARE THE ONLY WARRANTIES MADE BY ADIC. ADIC EXPRESSLY DISCLAIMS AND EXCLUDES ALL OTHER REMEDIES, EXPRESS OR IMPLIED, ORAL OR WRITTEN, ARISING BY LAW OR OTHERWISE INCLUDING PARTICULAR PURPOSE OR THOSE ARISING FROM COURSE OF DEALING, COURSE OF PERFORMANCE, OR TRADE USAGE.**
6. **BUYER ACKNOWLEDGES THAT ADIC HAS NOT MADE, AND BUYER IS NOT RELYING UPON, ANY EXPRESS OR IMPLIED WARRANTIES OR REPRESENTATIONS TO BUYER REGARDING THE VALUE OF THIS AGREEMENT.**

ADIC End User License Agreement

This License defines the terms and conditions of the license between Advanced Digital Information Corporation (ADIC) and Licensee for use of ADIC's software and related documentation. Any software or related materials provided to Licensee by ADIC will be subject to the terms and conditions of this License and by opening the accompanying package and/or by using the products, Licensee signifies its agreement with this license.

Software License.

License. In consideration of Licensee's payment of the License fees and subject to the terms of this License, ADIC grants to Licensee a personal, non-exclusive, non-transferable license to use the Software (Software is defined as the current version of the software products accompanying this license agreement in object code form only). A separate license is required for use of each Software program on each of Licensee's computers. The Software will be installed initially on Licensee's Designated Computer. Licensee may thereafter transfer the Software to another one of its computers of the same machine architecture, provided that the Software is installed on one (1) Designated Computer at a time.

Use. Licensee is authorized hereby to use the Software on one computer only (Designated Computer), or on backup equipment if the Designated Computer is inoperative until such time as the Designated Computer is restored to operation. This grant is specifically limited to use by the Licensee for normal, customary internal data processing, and specifically excludes Licensee's time-sharing or the rental of the Software or use of the Software in the development or marketing of a competitive or compatible product. No right to use, print, copy or display the Software or Documentation, in whole or in part, is granted hereby except as expressly provided in this License.

Copying. Licensee may make one (1) copy of the Software in a non-printed, machine-readable form for archival and back-up purposes only. In order to protect ADIC's trade secret and copyrights in the Software, Licensee agrees to reproduce and incorporate ADIC's trade secret or copyright notice in any copy or partial copy, and will maintain appropriate records of the location of such copy.

US Government Rights. If the Licensee is the United States government, Licensee understands and agrees that ADIC Software and documentation are provided as "Commercial Items" as defined at 48 CFR 2.101 and are being licensed to U.S. Government end users consistent with 48 CFR 12.212.

Software Ownership and Protection

Title to Software. The Software and all copies thereof are proprietary to ADIC and title thereto remains in ADIC. All applicable rights to patents, copyrights, trademarks, trade secrets or other proprietary rights in the Software and any modifications made at Licensee's request are and will remain in ADIC.

Restrictions. Licensee will not itself or permit others to: (i) sell, sublicense, transfer, publish, disclose, display, provide access via a network or otherwise make available the Software or any copy thereof to others; (ii) remove, obscure, or alter any copyright, trade secret, trademark, patent or other proprietary rights notice affixed to or displayed on the Software or Documentation; (iii) modify, merge with other programs or translate any portion of the Software into any other assembly or language; and (v) reverse-assemble, reverse-compile or attempt to derive a source code equivalent of the Software.

Protections. Licensee agrees to secure and protect the Software, the Documentation and copies thereof in a manner consistent with ADIC's rights therein and to take appropriate action to satisfy its obligations in this Agreement by instruction or agreement with its employees, agents, subcontractors or others who are permitted access to the Software. All programs or copies developed by or for Licensee in violation of this License, including translations, compilations, partial copies and up-dates, are owned by ADIC.

Responsibility. Licensee has sole responsibility for use of the products and any information entered, used, or stored thereon, including responsibility for protection of data from modification, destruction, or disclosure, and for the accuracy and integrity of the data. ADIC assumes no responsibility for Licensee's negligence or failure to protect its data.

Warranty and Warranty Servicing.

Warranty. ADIC warrants that for a period of 90 days from installation the Software will conform to all substantial operational features in ADIC's current published specifications and will be free of defects which substantially affect performance of the Software. ADIC does not warrant that the Software will meet the Licensee's requirements or that the operation of the Software will be uninterrupted or error free. The Licensee must notify ADIC in writing, within 90 days after installation of the Software of Licensee's claim of any defect. If ADIC determines that the Software is defective, ADIC's sole obligation is for ADIC, at its option, to correct, any defect in the Software or to accept the

return of the Software. Where Software is returned for claims made during the warranty period, Licensee will receive a refund for the Software. This warranty is made void if the Licensee or any third party makes any modifications to the Software. ADIC is not responsible for corrections necessitated by difficulties or defects traceable to Licensee's errors or system changes.

Compatibility. ADIC does not warrant that the Software is compatible with the current releases of all operating systems, nor that the Software will be made compatible with new releases of operating systems within a specified amount of time, or at all. At Licensee's request, ADIC will notify Licensee of the version level of the operating system with which the Software is intended to be compatible.

Warranty Disclaimer. EXCEPT FOR THE EXPRESS LIMITED WARRANTY STATED ABOVE, ADIC MAKES NO WARRANTIES, EXPRESS OR IMPLIED, FOR THE SOFTWARE, INCLUDING THE WARRANTIES OF MERCHANTABILITY AND FITNESS FOR A PARTICULAR PURPOSE.

Term and Termination. This License commences on the Effective Date and will continue in perpetuity unless Licensee fails to comply with any conditions of this License. If Licensee breaches, ADIC may, after allowing Licensee a reasonable time to cure its default, terminate this License upon written notice to the Licensee. Within 30 days after termination of this License, Licensee will certify, in writing, to ADIC, that Licensee has discontinued the use of all Software and returned to ADIC the original and all copies of the Software and Documentation in any form maintained by Licensee.

DISCLAIMER AND LIMITATION OF LIABILITY. THE LICENSEE HAS THE SOLE RESPONSIBILITY FOR THE ADEQUATE PROTECTION AND BACK-UP OF ITS DATA USED IN CONNECTION WITH THE SOFTWARE. IN NO EVENT WILL ADIC BE LIABLE FOR SPECIAL, INDIRECT, INCIDENTAL OR CONSEQUENTIAL DAMAGES OR ANY DAMAGES WHATSOEVER RESULTING FROM THE LOSS OF USE, DATA OR PROFITS, RERUN TIME, INACCURATE INPUT OR WORK DELAYS, OR ANY PERSONAL OR PROPERTY DAMAGE ARISING OUT OF OR IN CONNECTION WITH THIS LICENSE OR THE USE, PERFORMANCE OR NON-PERFORMANCE OF THE SOFTWARE, WHETHER IN ACTION, IN CONTRACT, OR TORT INCLUDING

NEGLIGENCE, EVEN IF ADIC KNEW, SHOULD HAVE KNOWN OR HAS BEEN ADVISED OF THE POSSIBILITY OF SUCH DAMAGES. ADIC's LIABILITY FOR DAMAGES HEREUNDER WILL IN NO EVENT EXCEED THE AMOUNT OF FEES PAID BY LICENSEE UNDER THIS LICENSE.

General.

No Assignment or Modification. This License is not assignable. None of the Software or Documentation may be sublicensed, assigned, or transferred to any other party without ADIC's prior written consent. Any effort contradictory with this is null and void. This License can only be modified by a written agreement executed by the parties.

Governing Law and Venue. The laws of the state of Washington will govern this license. All litigation between the parties, including all applications for injunctive relief, must be conducted before a court of competent jurisdiction in King County, Washington, USA and both parties consent to personal jurisdiction of such court. If any of the provisions of this License are held to be invalid under any applicable statute or law, they are, to that extent, deemed omitted.

Entirety. Licensee acknowledges that it has read this Software License, understands it, and agrees to be bound by its terms and conditions. Further, Licensee agrees that this is the complete and exclusive statement of the agreement between the parties and supersedes all proposals or prior agreements, oral or written and all other communications between the parties relating to the subject matter of this License. Any variance from the terms and conditions of this License or any supplement in any Licensee purchase order or other written notification or agreement will be of no effect.

INDEX

- A -

Action Reference Table 41
ADIC Management Console 105
AMC. See ADIC Management Console
Assigned LUN 47

- B -

Boot modes 187, 191
bootrom 110, 171, 197–203

- C -

calar 77
Channel Zoning 129
Command and Control LUN 51, 164
Configuration 9–10
 load 99
 save 99

- D -

Date 101
Device Access MAP 48
Diagnostic commands 187

- E -

Electrostatic discharge 81
Environmental notices 3
Ethernet 13, 106
 MAP 69
 network setup 87

- F -

Features 11
Fibre channel 11, 49, 61–66, 85
Firmware 170
 update 98
Frame size 108

- G -

GBIC 10, 123
 MAP 63
 remove 82
 replace 82

- H -

Hardware
 description 11
 maintenance. See MAPs
HBA 19
 setup 29
Help 8
Host
 event log 47
 Registration service. See HRS
Host Bus Adapter. See HBA
HRS 30
HyperTerminal 97

- I -

Installation 19–31

- L -

License key 110, 141
Loop ID 129

- M -

Maintenance Action Plans. See MAPs
MAPs 33–79

- N -

Netmask 72
Normal mode 113, 188

- O -

Operating specifications 16

- P -

POST 197–203
Power
 consumption 17
 down 2
 LED 15
 MAP 68
 requirements 17
Power-On Self Test. See POST

- R -

Recycling 3
Regulatory notices 4
Removal 81–84

Replacement 84–93

- S -

SAN Explorer 30
Scalar Firewall Manager 77–79
SCSI 10, 12
 LEDs 15
 target ID 25
SCSI bus 27
SCSI Channel 12, 49–61
SCSI target ID. See also Assigned LUN
Service port
 commands 105--186
 connecting to 95–104
 MAP 75
SFM. See Scalar Firewall Manager
SNC 5100 for the Scalar 1000 and 10K
 MAP 66–76
SNMP community strings 171
Specifications. See Operating specifications
Start MAP 42

- T -

Telnet 89
Temperature MAP 66
Troubleshooting 33–41

- W -

Warranty 211

- Z -

Zmodem 98
 status code table 100

