

# Quantum<sup>®</sup>

## Setup Guide

# Quantum StorNext QX Storage



StorNext QX Storage Setup Guide, 6-67860-01 Rev A, March 2013, Product of USA.

©2013 All rights reserved. Quantum, the Quantum logo, DXi, Scalar and StorNext are registered trademarks of Quantum Corporation and its affiliates in the United States and/or other countries. All other trademarks are the property of their respective owners.



# Contents

---

<b>About this guide</b> .....	<b>xi</b>
Intended audience .....	xi
Prerequisites .....	xi
Related documentation .....	xii
Document conventions and symbols .....	xiii

---

<b>1 Components</b> .....	<b>1</b>
StorNext QX-2400 front panel components .....	1
StorNext QX-1200 front panel components .....	2
Controller enclosure: Rear panel layout .....	3
StorNext QX-2400/StorNext QX-1200 controller module: Rear panel components .....	4
Component installation and replacement .....	4
Cache .....	5
CompactFlash .....	5
Supercapacitor pack .....	6

---

<b>2 Installing the enclosures</b> .....	<b>7</b>
Installation checklist .....	7
Network Equipment-Building System (NEBS) Level 3 compliance .....	8
Generic Requirements (GRs) .....	8
Connecting the controller enclosure and drive enclosures .....	9
Cable requirements for drive enclosures .....	9
Testing enclosure connections .....	14
Powering on/powering off .....	14
AC PSU .....	15
DC and AC PSUs with power switch .....	16

---

<b>3 Connecting hosts</b> .....	<b>19</b>
Host system requirements .....	19
Cabling considerations .....	19
Connecting the enclosure to hosts .....	19
FC host ports .....	20
Connecting direct attach configurations .....	20
Connecting switch attach configurations .....	22
Connecting a management host on the network .....	23
Updating Firmware .....	23

Obtaining IP values .....	23
Setting network port IP addresses using DHCP .....	23
Setting network port IP addresses using the CLI .....	24
<hr/>	
<b>4 Basic operation .....</b>	<b>29</b>
CLI .....	29
Signing in to the CLI .....	29
Quantum StorNext Disk Storage Management Utility .....	30
Browser setup .....	30
Signing in to the Quantum StorNext Disk Storage Management Utility .....	30
Configuring and provisioning the storage system .....	31
Best practices for optimal performance .....	31
<hr/>	
<b>5 Troubleshooting .....</b>	<b>33</b>
USB CLI port connection .....	33
Fault isolation methodology .....	33
Basic steps .....	33
Options available for performing basic steps .....	34
Performing basic steps .....	34
If the enclosure does not initialize .....	36
Correcting enclosure IDs .....	36
Stopping I/O .....	37
Diagnostic steps .....	37
Is the enclosure front panel "Fault/Service Required" LED amber? .....	38
Is the controller rear panel "FRU OK" LED lit? .....	38
Is the controller rear panel "Fault/Service Required" LED amber? .....	38
Are both disk drive module LEDs off? .....	39
Is the disk drive module "Fault" LED amber? .....	39
Is a connected host port's "Host Link Status" LED lit? .....	39
Is a connected port's "Expansion Port Status" LED lit? .....	40
Is a connected port's "Network Port Link Status" LED lit? .....	40
Is the PSU's "Input Power Source" LED lit? .....	41
Is the "Voltage/Fan Fault/Service Required" LED amber? .....	41
Isolating a host-side connection fault .....	42
Host-side connection troubleshooting featuring FC host ports .....	42
Isolating a controller module expansion port connection fault .....	43
Resolving voltage and temperature warnings .....	44
Sensor locations .....	45
PSU sensors .....	45
Cooling fan sensors .....	45
Temperature sensors .....	46
PSU voltage sensors .....	46
<hr/>	
<b>A LED descriptions .....</b>	<b>47</b>
StorNext QX-2400 front panel LEDs .....	47
StorNext QX-1200 front panel LEDs .....	49
Disk drive LEDs .....	51
Controller enclosure: Rear panel layout .....	53
StorNext QX-2400/StorNext QX-1200 controller module: Rear panel LEDs .....	54
PSU LEDs .....	56
QX 24-Drive Expansion Module/QX 12-Drive Expansion Module drive enclosure rear panel LEDs .....	56
<hr/>	
<b>B Environmental requirements and specifications .....</b>	<b>59</b>
Safety requirements .....	59

Site requirements and guidelines . . . . .	59
Site wiring and AC power requirements . . . . .	59
Site wiring and DC power requirements . . . . .	60
Weight and placement guidelines . . . . .	61
Electrical guidelines . . . . .	61
Ventilation requirements . . . . .	61
Cabling requirements . . . . .	61
Management host requirements . . . . .	62
Physical requirements . . . . .	62
Environmental requirements . . . . .	64
Electrical requirements . . . . .	64
Site wiring and power requirements . . . . .	64
Power cable requirements . . . . .	65
<hr/>	
<b>C Electrostatic discharge . . . . .</b>	<b>67</b>
Grounding methods to prevent ESD . . . . .	67
<hr/>	
<b>D USB device connection . . . . .</b>	<b>69</b>
Rear panel USB ports . . . . .	69
USB the CLI port . . . . .	69
Emulated serial port . . . . .	70
Supported host applications . . . . .	70
CLI . . . . .	70
Device driver/special operation mode . . . . .	70
Microsoft Windows . . . . .	71
Linux . . . . .	71
<hr/>	
<b>Glossary . . . . .</b>	<b>73</b>
<hr/>	
<b>Index . . . . .</b>	<b>77</b>





# Figures

---

1	StorNext QX-2400 with bezel installed	1
2	StorNext QX-2400 with bezel removed	2
3	StorNext QX-1200 with bezel installed	2
4	StorNext QX-1200 with bezel removed	3
5	Representative controller enclosure: Rear panel layout	3
6	StorNext QX-2400/StorNext QX-1200 controller module	4
7	CompactFlash	6
8	Cabling connections between a dual-controller enclosure and one drive enclosure	11
9	Fault-tolerant cabling between a dual-controller enclosure and four drive enclosures	12
10	Reverse cabling between a dual-controller enclosure and seven drive enclosures	13
11	AC PSU	15
12	AC power cord	15
13	DC and AC PSUs with power switch	16
14	DC power cable featuring D-shell and lug connectors	17
15	Connecting hosts: One server and one HBA, dual path	21
16	Connecting hosts: Two servers and one HBA per server, dual path	21
17	Connecting hosts: Four servers and one HBA per server, dual path	22
18	Connecting hosts: Switch attach: multiple servers/switches	22
19	Connecting a USB cable to the CLI port	24
20	StorNext QX-2400 with bezel installed	47
21	StorNext QX-2400 with bezel removed	48
22	StorNext QX-1200 with bezel installed	49
23	12-disk enclosure with bezel removed	50
24	Disk drives	51
25	Example controller enclosure: Rear panel layout	53
26	StorNext QX-2400/StorNext QX-1200 controller module	55
27	PSUs	56
28	QX 24-Drive Expansion Module/QX 12-Drive Expansion Module drive enclosure	57
29	USB device connection: CLI port	69







# Tables

---

1	Related documents	. . . . .	xii
2	Document conventions	. . . . .	xiii
3	Installation checklist	. . . . .	7
4	Summary of Mini-SAS cable type requirements and related enclosure characteristics	. . . . .	10
5	Maximum cable lengths for 850nm FC SFP transceivers	. . . . .	20
6	Terminal emulator display settings	. . . . .	25
7	Terminal emulator connection settings	. . . . .	25
8	Solutions to degraded performance	. . . . .	31
9	Diagnostics LED status: Front panel "Fault/Service Required"	. . . . .	38
10	Diagnostics LED status: Rear panel "FRU OK"	. . . . .	38
11	Diagnostics LED status: Rear panel "Fault/Service Required"	. . . . .	38
12	Diagnostic LED status: Disk drive module	. . . . .	39
13	Diagnostics LED status: Disk drive "Fault" LED (LFF and SFF modules)	. . . . .	39
14	Diagnostics LED status: Rear panel "Host Link Status"	. . . . .	39
15	Diagnostics LED status: Rear panel "Expansion Port Status"	. . . . .	40
16	Diagnostics LED status: Rear panel "Network Port Link Status"	. . . . .	40
17	Diagnostics LED status: Rear panel PSU "Input Power Source"	. . . . .	41
18	Diagnostics LED status: Rear panel PSU "Voltage/Fan Fault/Service Required"	. . . . .	41
19	PSU sensor descriptions	. . . . .	45
20	Cooling fan sensor descriptions	. . . . .	45
21	Controller module temperature sensor descriptions	. . . . .	46
22	PSU temperature sensor descriptions	. . . . .	46
23	Voltage sensor descriptions	. . . . .	46
24	LEDs: 2U24 enclosure front panel (bezel installed)	. . . . .	47
25	LEDs: 2U24 enclosure front panel (bezel removed)	. . . . .	48
26	LEDs: 2U12 enclosure front panel (bezel installed)	. . . . .	49
27	LEDs: 2U12 enclosure front panel (bezel removed)	. . . . .	50
28	LEDs: Disk drive	. . . . .	51
29	LEDs: Disks in LFF and SFF enclosures	. . . . .	52
30	LEDs: Vdisks in LFF and SFF enclosures	. . . . .	52
31		. . . . .	54
32		. . . . .	56
33		. . . . .	57
34	Power requirements - AC Input	. . . . .	59
35	Power requirements - DC Input	. . . . .	60
36	Rackmount enclosure dimensions	. . . . .	63
37	Rackmount controller enclosure weights	. . . . .	63
38	Rackmount compatible drive enclosure weights (ordered separately)	. . . . .	63
39	Operating environmental specifications	. . . . .	64
40	Non-operating environmental specifications	. . . . .	64

41 Supported terminal emulator applications . . . . .	70
42 USB vendor and product identification codes . . . . .	70



# About this guide

---

This guide provides information about hardware setup for the Quantum StorNext QX Storage products listed below:

StorNext Base Systems - FC Controller Enclosure

- StorNext QX-2400
- StorNext QX-1200

The StorNext QX Storage enclosures are NEBS Level 3, MIL-STD-810G (storage requirements), and European Telco compliant. The StorNext QX Storage enclosures support either LFF 12-disk or SFF 24-disk 2U drive enclosures, using either AC or DC power supplies. See the Quantum web site for more information about specific models and uses: <http://www.quantum.com>.

---

## Intended audience

This guide is intended for storage system administrators.

---

## Prerequisites

Prerequisites for installing and using this product include knowledge of:

- Servers and computer networks
- Network administration
- Storage system installation and configuration
- SAN management and DAS
- FC and Ethernet protocols

---

## Related documentation

**Table 1** Related documents

<b>For information about</b>	<b>See</b>
Web links to download Quantum QX Storage guides listed below, but not shipped with the product	Documentation sheet*
Enhancements, known issues, and late-breaking information not included in product documentation	Quantum StorNext QX Storage Release Notes
Product overview and overview of setup tasks	Quantum StorNext QX Storage Getting Started Guide
Regulatory compliance and safety and disposal information	Quantum Product Regulatory Compliance and Safety*
Using a rackmount bracket kit to install an enclosure into a rack	Quantum StorNext QX Storage Rackmount Bracket Kit Installation Guide
Installing the front bezel on a Quantum StorNext QX-1200 system	Quantum StorNext QX Storage QX-1200 Bezel Installation Guide
Using the CLI to configure and manage the product	Quantum StorNext QX Storage CLI Reference Guide
Using the web interface to configure and manage the product	Quantum StorNext QX Storage Disk Management Utility Guide
Event codes and recommended actions Identifying and installing or replacing FRUs	Quantum StorNext QX Storage Service Guide

\* Printed document included with product

For additional information, go to Quantum's website, [www.quantum.com](http://www.quantum.com)

---

# Document conventions and symbols

**Table 2** Document conventions

Convention	Element
Blue text	Cross-reference links and e-mail addresses
<a href="#">Blue, underlined text</a>	Web site addresses
<b>Bold text</b>	<ul style="list-style-type: none"><li>• Key names</li><li>• Text typed into a GUI element, such as into a box</li><li>• GUI elements that are clicked or selected, such as menu and list items, buttons, and check boxes</li></ul>
<i>Italic text</i>	Text emphasis
Monospace text	<ul style="list-style-type: none"><li>• File and directory names</li><li>• System output</li><li>• Code</li><li>• Text typed at the command-line</li></ul>
<i>Monospace, italic text</i>	<ul style="list-style-type: none"><li>• Code variables</li><li>• Command-line variables</li></ul>
<b>Monospace, bold text</b>	Emphasis of file and directory names, system output, code, and text typed at the command-line

---

 **WARNING!** Indicates that failure to follow directions could result in bodily harm or death.

---

---

 **CAUTION:** Indicates that failure to follow directions could result in damage to equipment or data.

---

---

 **IMPORTANT:** Provides clarifying information or specific instructions.

---

---

 **NOTE:** Provides additional information.

---

---

 **TIP:** Provides helpful hints and shortcuts.

---





# Chapter 1

## Components

The StorNext QX Storage drive enclosures include a bezel sub-assembly that attaches to the front panel of the chassis (see [Figure 1](#) and [Figure 3](#)). The bezel, comprised of a vented cover attached to an EMI shield, is pre-assembled and packed within a box contained in the enclosure master shipping container. The bezel might optionally include a removable air filter that can be serviced or replaced. Hard copy instructions for attaching/removing the bezel, and for servicing or replacing the air filter, are provided in the *Quantum StorNext QX Storage QX-1200 Bezel Installation Guide*.

### StorNext QX-2400 front panel components

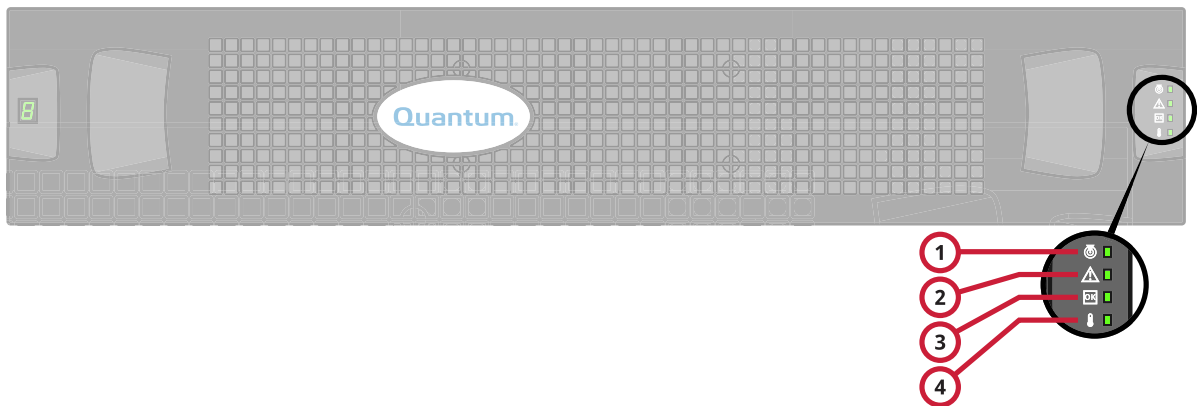

- |  |   |
|--|---|
| 1 Enclosure status LED: Unit Locator           | 3 Enclosure status LED: FRU OK            |
| 2 Enclosure status LED: Fault/Service Required | 4 Enclosure status LED: Temperature Fault |

**Figure 1** StorNext QX-2400 with bezel installed

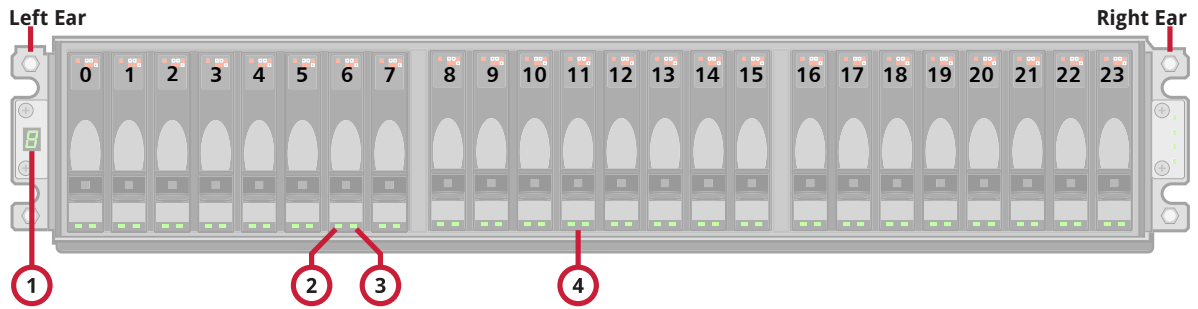

Note: Integers on disks indicate disk slot numbering sequence.

- |   |  |
|---|--|
| 1 Enclosure ID LED                      | 3 Disk drive status LED: Fault             |
| 2 Disk drive status LED: Power/Activity | 4 2.5" disk drive blank (typical 24 slots) |

Figure 2 StorNext QX-2400 with bezel removed

## StorNext QX-1200 front panel components

△ CAUTION: Whether configured with or without an air filter, to ensure adequate EMI protection for the disk drives, the bezel should be properly installed while the enclosure is in operation.

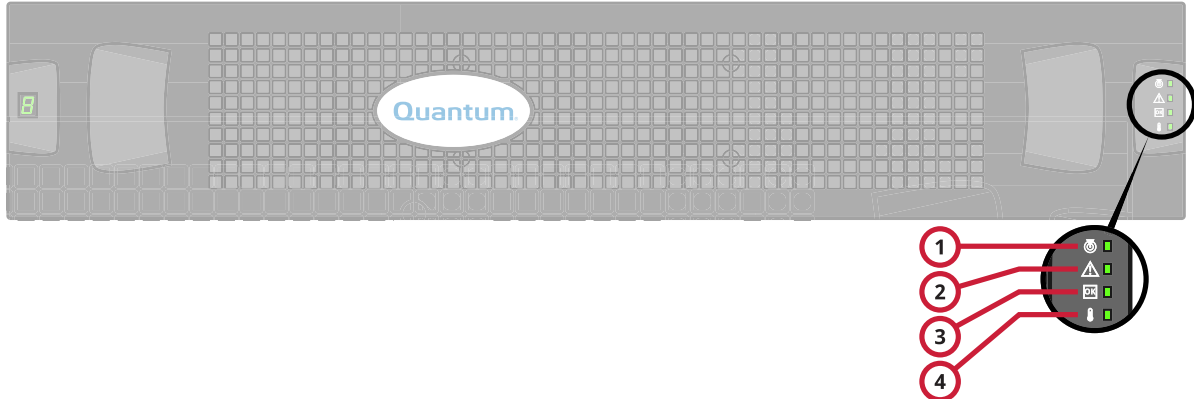

- |  |   |
|--|---|
| 1 Enclosure status LED: Unit Locator           | 3 Enclosure status LED: FRU OK            |
| 2 Enclosure status LED: Fault/Service Required | 4 Enclosure status LED: Temperature Fault |

Figure 3 StorNext QX-1200 with bezel installed



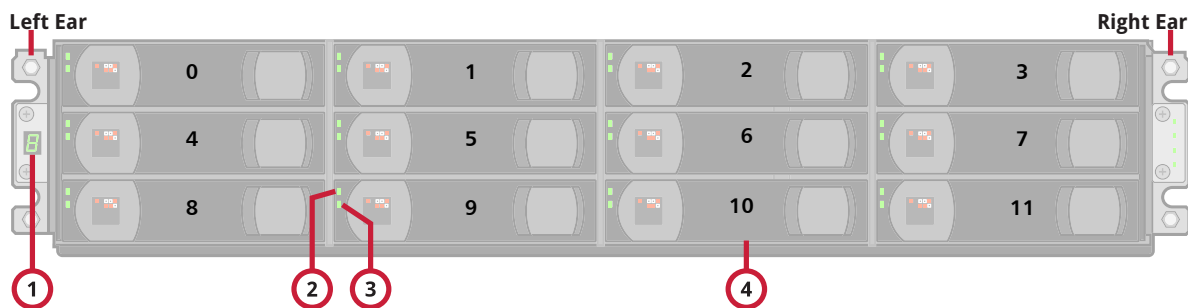

**Note:** Integers on disks indicate disk slot numbering sequence.

- |   |  |
|---|--|
| 1 Enclosure ID LED                      | 3 Disk drive status LED: Fault             |
| 2 Disk drive status LED: Power/Activity | 4 3.5" disk drive blank (typical 12 slots) |

**Figure 4** StorNext QX-1200 with bezel removed

 **NOTE:** LEDs for StorNext QX Storage controller enclosures are described in Appendix A, [LED descriptions](#).

## Controller enclosure: Rear panel layout

The diagram and table below display and identify important component items that comprise the rear panel layout of a Quantum StorNext QX Storage controller enclosure. The following image shows a representative example of controller enclosure models included in the product series.

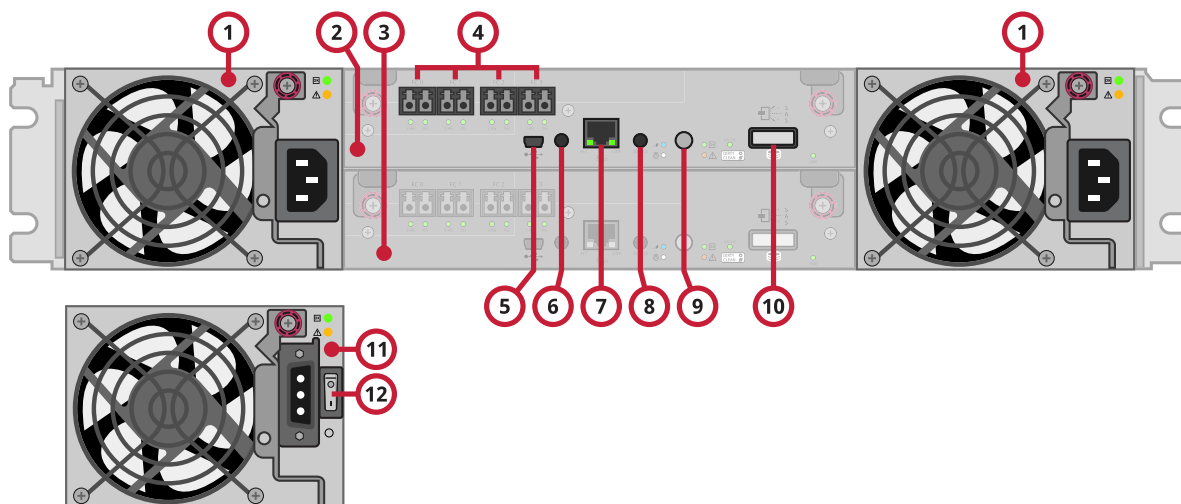

- |   |   |
|---|---|
| 1 AC power supplies                                 | 7 Network port                                    |
| 2 Controller module A                               | 8 Service port (used by service personnel only)   |
| 3 Controller module B                               | 9 Disabled button (used by engineering/test only) |
| 4 FC ports: host interface or replication           | 10 Expansion port                                 |
| 5 CLI port (USB - Type B)                           | 11 DC Power supply (2) — (DC model only)          |
| 6 Host port (USB - Type A; reserved for future use) | 12 DC Power switch                                |

**Figure 5** Representative controller enclosure: Rear panel layout

A controller enclosure accommodates two PSU FRUs of the same type — either both AC or both DC — within the two PSU slots (see two instances of callout No.1 above). The controller enclosure accommodates two controller module FRUs of the same type within the IOM slots (see callouts No.2 and No.3 above).

**IMPORTANT:** All StorNext QX Storage configurations are dual-controller. Single-controller support is provided only when a controller fails over to its partner controller. A controller module must be installed in each IOM slot to ensure sufficient airflow through the enclosure during operation.

Figure 6 provides descriptions for the different controller modules and PSUs that can be installed into the rear panel of a StorNext QX Storage controller enclosure. Showing controller modules and PSUs separately from the enclosure enables improved clarity in identifying the component items called out in the diagrams and described in the tables.

Descriptions are also provided for optional drive enclosures supported by StorNext QX Storage controller enclosures.

## StorNext QX-2400/StorNext QX-1200 controller module: Rear panel components

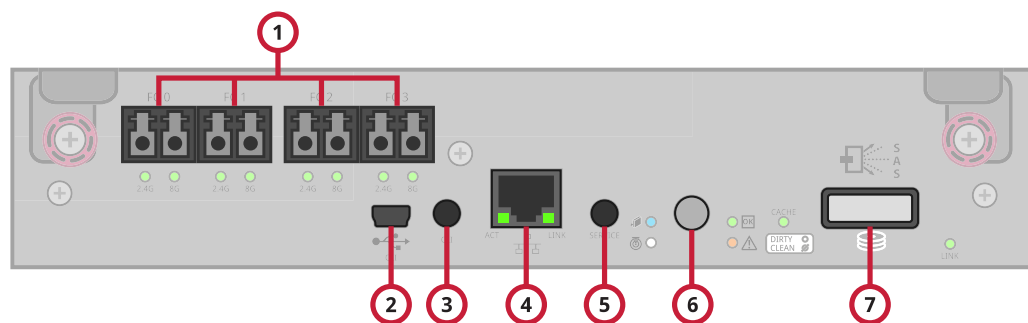

- |  |   |
|--|---|
| 1 Host interface ports (FC)  | 5 Service port (used by service personnel only)   |
| 2 CLI port (USB - Type B) [see <a href="#">USB device connection</a> on page 69] | 6 Disabled button (used by engineering/test only) |
| 3 Reserved for future use  | 7 Expansion port                                  |
| 4 Network port   |   |

Figure 6 StorNext QX-2400/StorNext QX-1200 controller module

## Component installation and replacement

Installation and replacement of StorNext QX Storage FRUs is addressed in the StorNext QX Storage Service Guide within the “Procedures” chapter.

FRU procedures facilitate replacement of a damaged chassis or chassis component:

- Replacing a controller or expansion module
- Replacing a disk drive module
- Replacing a power supply unit (AC and DC units with integrated cooling fans)

- Replacing ear bezels
- Replacing an FC transceiver
- Replacing a controller enclosure chassis

---

## Cache

To enable faster data access from disk storage, the following types of caching are performed:

- Write-back or write-through caching.
  - Write-back. The controller receives the data to be written to disks, stores it in the memory buffer, and immediately sends the host operating system a signal that the write operation is complete, without waiting until the data is actually written to the disk. Write-back cache mirrors all of the data from one controller module cache to the other. Write-back cache improves the performance of write operations and the throughput of the controller.
  - Write-through. The controller writes the data to the disks before signaling the host operating system that the process is complete. Write-through cache has lower write operation and throughput performance than write-back, but it is the safer strategy, with minimum risk of data loss on power failure. However, write-through cache does not mirror the write data because the data is written to the disk before posting command completion and mirroring is not required.
- Read-ahead caching. The controller detects sequential data access, reads ahead into the next sequence of data (based upon settings) and stores the data in the read-ahead cache. Then, if the next read access is for cached data, the controller immediately loads the data into the system memory, avoiding the latency of a disk access.

---

 **TIP:** See the “About volume cache options” and “Changing system cache settings” topics in the *Quantum Disk Storage Management Utility Users Guide* for setting options.

---

---

## CompactFlash

During a power loss or controller failure, data stored in cache is saved to non-volatile memory (CompactFlash). The data is restored to cache, and then written to disk after the issue is corrected. CompactFlash provides unlimited cache memory backup time. To protect against writing incomplete data to disk, the image stored on the CompactFlash is verified before committing to disk.

The CompactFlash card is located at the midplane-facing end of the controller module as shown below. Do not remove the card; it is used for cache recovery only.

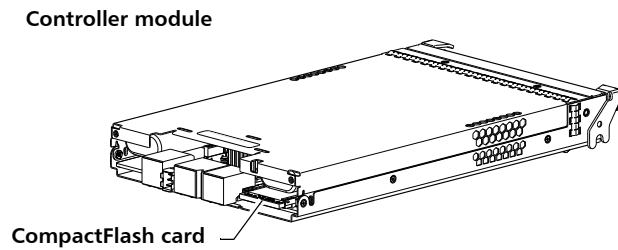

Figure 7 CompactFlash

---

 **IMPORTANT:** Customer removal of CompactFlash will void the product warranty.

---

---

## Supercapacitor pack

To protect controller module cache in case of power failure, each controller enclosure model is equipped with supercapacitor technology, in conjunction with CompactFlash memory, built into each controller module to provide unlimited cache memory backup time. The supercapacitor pack provides energy for backing up unwritten data in the write cache to the CompactFlash, in the event of a power failure. Unwritten data in CompactFlash memory is automatically committed to disk media when power is restored. In the event of power failure, while cache is maintained by the supercapacitor pack, the Cache Status LED flashes at a rate of 1/10 second on and 9/10 second off.



# Installing the enclosures

## Installation checklist

Table 3 outlines the steps required to install the enclosures, and initially configure and provision the storage system. To ensure successful installation, perform the tasks in the order presented.

**Table 3** Installation checklist

Step	Task	Where to find procedure
1	Install the controller enclosure and optional drive enclosures in the rack, and attach the enclosure bezel. <sup>1</sup>	See the rack-mount bracket kit installation instructions pertaining to your enclosure. If your product uses a bezel, see its bezel kit installation instructions.
2	Connect controller enclosure and optional drive enclosures.	See <a href="#">Connecting the controller enclosure and drive enclosures</a> on page 9.
3	Connect power cords.	See <a href="#">Power Cords</a> on page 16.
4	Test enclosure connectivity.	See <a href="#">Testing enclosure connections</a> on page 14.
5	Install required host software.	See <a href="#">Host system requirements</a> on page 19.
6	Connect hosts. <sup>2</sup>	See <a href="#">Connecting the enclosure to hosts</a> on page 19.
7	Connect management hosts. <sup>2</sup>	See <a href="#">Connecting a management host on the network</a> on page 23.
8	Obtain IP values and set network port IP properties on the controller enclosure.	See <a href="#">Obtaining IP values</a> on page 23. For USB CLI port and cable use, see Appendix D, <a href="#">USB device connection</a> on page 69.
9	Perform initial configuration tasks <sup>3</sup> : <ul style="list-style-type: none"> <li>• Sign-in to the Quantum StorNext Disk Storage Management Utility.</li> <li>• Initially configure and provision the system using the Quantum StorNext Disk Storage Management Utility</li> </ul>	Topics below correspond to bullets at left: See "Getting Started" in the <i>StorNext QX Storage Disk Storage Management Utility Users Guide</i> . See "Configuring the System" and "Provisioning the System" topics in the <i>StorNext QX Storage Disk Storage Management Utility Users Guide</i> .

<sup>1</sup>Also see the *StorNext QX Storage Service Guide* for illustrations showing installation of enclosure ear caps or the enclosure bezel that is provided with some models.

<sup>2</sup>For more about hosts, see the “About hosts” topic in the *StorNext QX Storage Disk Storage Management Utility Users Guide*.

<sup>3</sup>For additional information on the Quantum StorNext Disk Storage Management Utility, see the Disk Storage Management Utility Users Guide.

---

 **NOTE:** Controller modules within the same enclosure must be of the same type.

---

---

## Network Equipment-Building System (NEBS) Level 3 compliance

### Generic Requirements (GRs)

Meets the NEBS requirement of GR-1089-CORE Issue 5, port types 2, 7 & 8.

Meets the NEBS requirements of GR-63-CORE Issue 3, for the product’s intended use.

---

 **NOTE:** [Table 4](#) on page 10 shows NEBS-compliance for individual storage enclosures.

---

### Exceptions to GRs

Exceptions to the overall NEBS GR-63-CORE Issue 3 requirements include:

- Heat Dissipation: Environmental Criteria Section 4.1.6, Operational Requirement O4-20. This product exceeds the Optional Requirements shown in Table 4-5 for Forced-Air Fan Shelf equipment.
- Airborne Contaminants: This product is designed for indoor use only, and has not been tested for Outdoor Contaminant Levels (Table 4-11); per Requirement R4-86 (Environmental Criteria section 4.5.2.2).
- Equipment — Fan Filters: Environmental Criteria Section 4.5.4. This product does not have a fan filter, and has not been tested by any requirements in section 4.5.4. The following requirements have not been tested: R4-87 [138]; R4-88 [139]; R4-89 [176]; R4-90 [140]; R4-91 [141]; R4-92 [142]; R4-93 [143]; O4-94 [144] and O4-95 [145].
- This product does not meet the requirements of Spatial Requirements, Section 2.

Exceptions to the overall NEBS GR-1089-CORE Issue 5 requirements include:

- None reported

### Product documentation requirements

NEBS product documentation requirements applying to Quantum StorNext QX Storage controller and drive enclosures are listed beneath “NEBS (Level 3)” in the Index — under either GR-1089-CORE Issue 5 or GR-63-CORE Issue 3 — together with adjacent page locations. NEBS topics are *integrated* within the overall content of this setup guide. The requirement designators in the Index have been codified for use within index marker tags according to the following example:

NEBS generic requirement number “R1-3 [155]” appears as “R1-3.155” within the Index.

Each codified string (e.g., R1-3.155) is followed by a hyphen and brief description of the requirement. Within the Index, click on the [blue page number](#) link to navigate to the corresponding NEBS topic.

---

# Connecting the controller enclosure and drive enclosures

Quantum StorNext QX Storage controller enclosures, available in either 24-disk (2.5") or 12-disk (3.5") chassis, support up to eight enclosures (including the controller enclosure), or a maximum of 192 disk drives. The StorNext QX Storage enclosures support both straight-through and reverse SAS cabling. Reverse cabling allows any drive enclosure to fail or be removed while maintaining access to other enclosures. Fault tolerance and performance requirements determine whether to optimize the configuration for high availability or high performance when cabling.

---

**△ CAUTION:** Some 6-Gbit/s disks might not consistently support a 6-Gbit/s transfer rate. If this happens, the system automatically adjusts transfers to those disks to 3-Gbit/s, increasing reliability and reducing error messages with little impact on system performance. This rate adjustment persists until the controller is restarted or power-cycled.

---

Cabling diagrams in this section show fault-tolerant cabling patterns. Controller and expansion modules are identified by <enclosure-ID><controller-ID>. When connecting multiple drive enclosures, use reverse cabling to ensure the highest level of fault tolerance, enabling controllers to access remaining drive enclosures if a drive enclosure fails.

For example, [Figure 9](#) on page 12 shows reverse cabling wherein controller 0A (i.e., enclosure-ID = 0; controller-ID = A) is connected to expansion module 1A, with a chain of connections cascading down (blue). Controller 0B is connected to the lower expansion module (B) of the last drive enclosure in the chain, with connections moving in the opposite direction (green). Several cabling examples are provided on the following pages.

---

 **NOTE:** Quantum StorNext QX Storage controller enclosures support hot-plug replacement of redundant controller modules, fans, power supplies, and IOMs. Hot-add of drive enclosures is also supported.

---

## Cable requirements for drive enclosures

StorNext QX Storage enclosures support 6-Gbit/s expansion port data rates. Observe the following guidelines when installing SAS cables:

- Use only Quantum or OEM-qualified SAS cables appropriate for connecting the drive enclosure:
  - Use cables providing 6-Gbit/s data rate per lane with four lanes (4x) per SAS connector:
    - When connecting a controller-enclosure to a disk-enclosure, the cable length should not exceed 2.0 meters
    - When connecting disk-enclosures to one another, cable lengths should not exceed 2.0 meters
  - Qualified cables of 0.6 meter length may be used for cabling stacked components in cascaded fashion
  - Mini-SAS to mini-SAS cables denote SFF-8088 to SFF-8088
  - You may need to order additional or longer cables when reverse-cabling a fault-tolerant configuration.
  - Cables required, if not included, must be purchased separately.

[Table 4](#) summarizes key characteristics of controller enclosures and compatible drive (expansion) enclosures relative to cabling, including: the cable type needed for attaching one specific enclosure model to another specific enclosure model; internal disk drive speeds; number of disks of given size (SFF or LFF) supported per enclosure model; and SAS expander data rates. Enclosure form factor (2U24/2U12) and NEBS compliance information are also provided.

**Table 4** Summary of Mini-SAS cable type requirements and related enclosure characteristics

Model	StorNext QX Storage 2U24 controller enclosure	StorNext QX Storage 2U12 controller enclosure	QX 24-Drive Expansion Module (mini-SAS)
StorNext QX-2400	Not Applicable		mini-SAS to mini-SAS
StorNext QX-1200			mini-SAS to mini-SAS
StorNext QX 24-Drive Expansion Module	mini-SAS to mini-SAS	mini-SAS to mini-SAS	mini-SAS to mini-SAS
StorNext QX 12-Drive Expansion Module	mini-SAS to SAS	mini-SAS to SAS	mini-SAS to SAS

Controller enclosure/chassis designators:

2U24: Enclosure measuring two rack units high, providing 24-drives and smaller depth dimension than 2U12.

2U12: Enclosure measuring two rack units high, providing 12-drives, and larger footprint than 2U24.

Compatible product models featuring 6-Gbps internal disk and SAS expander link speeds.

StorNext QX-2400: FC controller enclosure (2.5" disks in 2U24 chassis) [NEBS]

StorNext QX-1200: FC controller enclosure (3.5" disks in 2U12 chassis) [NEBS]

QX 24-Drive Expansion Module: 24-drive expansion enclosure (2.5" disks in 2U24 chassis) [NEBS]

QX 12-Drive Expansion Module: 12-drive expansion enclosure (3.5" disks in 2U12 chassis) [NEBS]

See [Physical requirements](#) on page 62 for more information about 2U24 and 2U12 enclosures.

 **NOTE:** For clarity, the schematic diagrams show only relevant details such as face-plate outlines and expansion ports. For detailed illustrations, see [Controller enclosure: Rear panel layout](#) on page 53. Also see the controller module face plate illustrations that follow the rear panel layout.



## Drive enclosure cabling illustrations

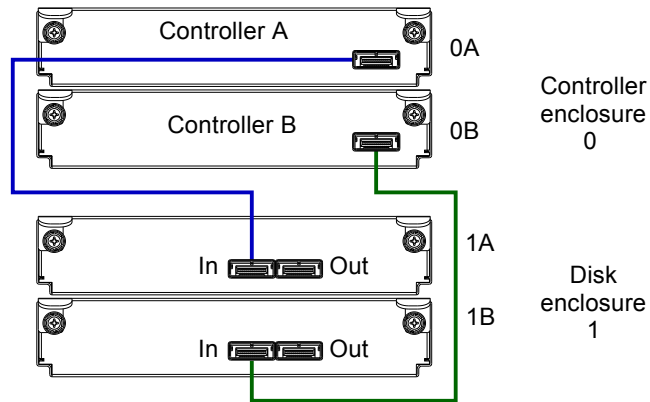

**Figure 8** Cabling connections between a dual-controller enclosure and one drive enclosure

**Figure 8** shows a StorNext QX Storage dual-controller enclosure cabled to QX 24-Drive Expansion Module/QX 12-Drive Expansion Module drive enclosures featuring dual-expansion modules. Controller module 0A is connected to expansion module 1A (blue). Controller module 0B is connected to expansion module 1B (green).

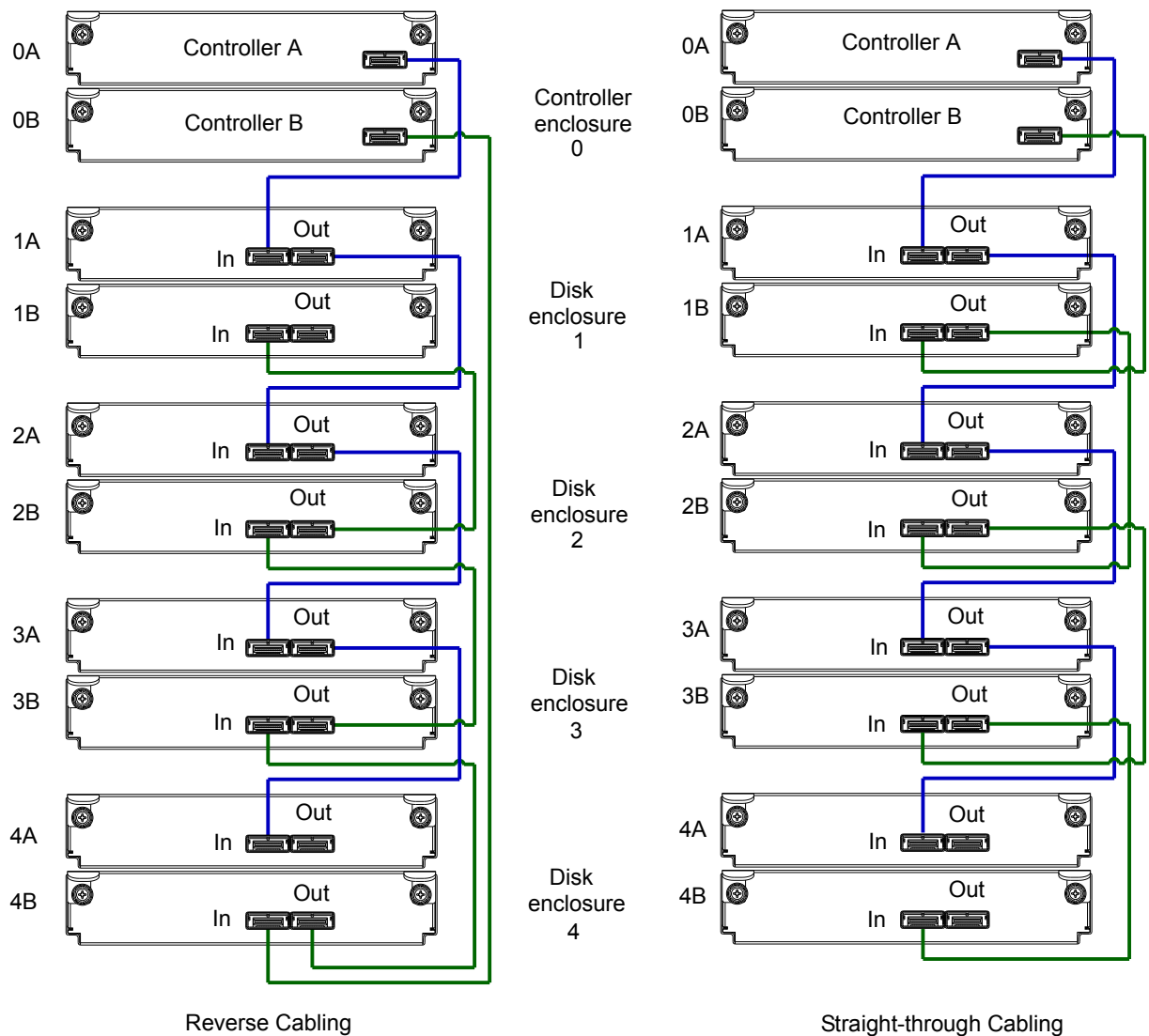
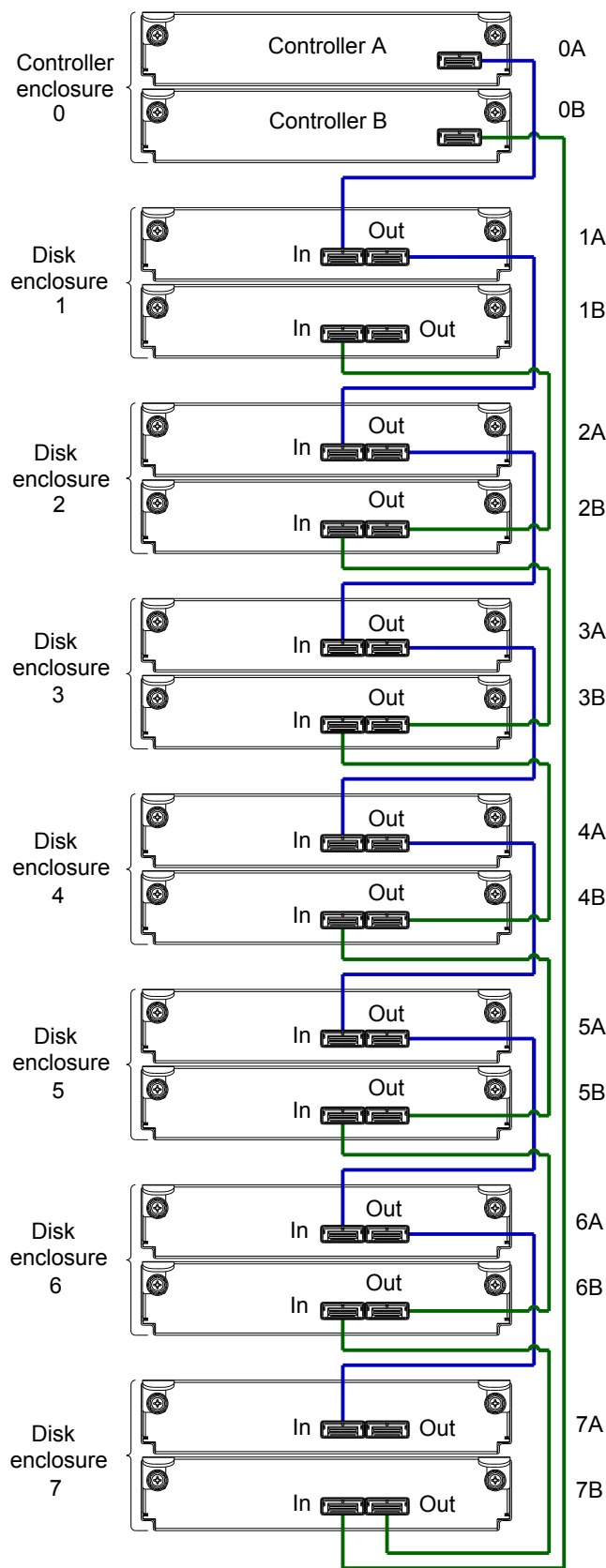

**Figure 9** Fault-tolerant cabling between a dual-controller enclosure and four drive enclosures

The diagram at left in [Figure 9](#) shows reverse cabling of a dual-controller enclosure and QX 24-Drive Expansion Module/QX 12-Drive Expansion Module 6 Gb drive enclosures configured with dual-expansion modules. Controller module 0A is connected to expansion module 1A, with a chain of connections cascading down (blue). Controller module 0B is connected to the lower expansion module (4B), of the last drive enclosure, with connections moving in the opposite direction (green). Reverse cabling allows any drive enclosure to fail—or be removed—while maintaining access to other enclosures.

The diagram at right in [Figure 9](#) shows the same storage components connected using straight-through cabling. Using this method, if a drive enclosures fails, the enclosures that follow the failed enclosure in the chain are no longer accessible until the failed enclosure is repaired or replaced.

Refer to these diagrams when cabling multiple compatible drive enclosures together with the StorNext QX Storage controller enclosure.



**Note:**  
The maximum number of supported drive enclosures (7) may require purchase of additional longer cables.

**Figure 10** Reverse cabling between a dual-controller enclosure and seven drive enclosures

**Figure 10** shows a StorNext QX Storage dual-controller enclosure cabled to StorNext QX 24-Drive Expansion Module / StorNext QX 12-Drive Expansion Module drive enclosures featuring

dual-expansion modules. Controller module 0A is connected to expansion module 1A, with a chain of connections cascading down (blue). Controller module 0B is connected to the lower expansion module (7B), of the last drive enclosure, with connections moving in the opposite direction (green).

---

## Testing enclosure connections

---

 **NOTE:** For NEBS applications, verify that you are using compatible PSUs and drive enclosures.

---

Power cycling procedures vary according to the type of PSU provided with the enclosure. Some enclosure models are equipped with PSUs possessing power switches; whereas other enclosures use PSUs that have no power switch.

[Powering on/powering off](#) describes power cycling procedures relative to different types of PSUs installed within enclosures. Once the power-on sequence succeeds, the storage system is ready to be connected to hosts as described in [Connecting the enclosure to hosts](#) on page 19.

---

## Powering on/powering off

Before powering on the enclosure for the *first* time:

- Install all disk drives in the enclosure so the controller can identify and configure them at power-up.
- Connect the cables and power cords to the enclosure as described in this document.

---

 **NOTE:** Newer AC PSUs do not have power switches. *Switchless* PSUs power on when connected to a power source, and power off when disconnected.

---

- Generally, when powering up, make sure to power up the enclosures and associated data host in the following order:
  - Drive enclosures first  
This ensures that the disks in the drive enclosure have enough time to completely spin up before being scanned by the controller modules within the controller enclosure.  
While enclosures power up, their LEDs blink. After the LEDs stop blinking and no LEDs on the front and rear of the enclosure are amber, the power-on sequence is complete, and no faults have been detected. See Appendix A, [LED descriptions](#) for descriptions of LED behavior.
  - Controller enclosure next  
Depending upon the number and type of disks in the system, it may take several minutes for the system to become ready.
  - Data host last (if powered down for maintenance purposes).

---

 **TIP:** Generally, when powering off, you will reverse the order of steps used for powering on.

---

Power cycling procedures vary according to the type of PSU included within the enclosure. For controller and drive enclosures configured with switchless AC PSUs, refer to the procedure described in [AC PSU](#) on page 15. For procedures pertaining to a) controller enclosures configured with DC PSUs,

or b) previously installed drive enclosures featuring power switches, see [DC and AC PSUs with power switch](#) on page 16.

## AC PSU

Controller and drive enclosures configured with switchless PSUs rely on the power cord for power cycling. Power-on the enclosure by connecting the cord from the PSU power cord connector to the appropriate power source; power-off the enclosure by disconnecting the cord from the power source.

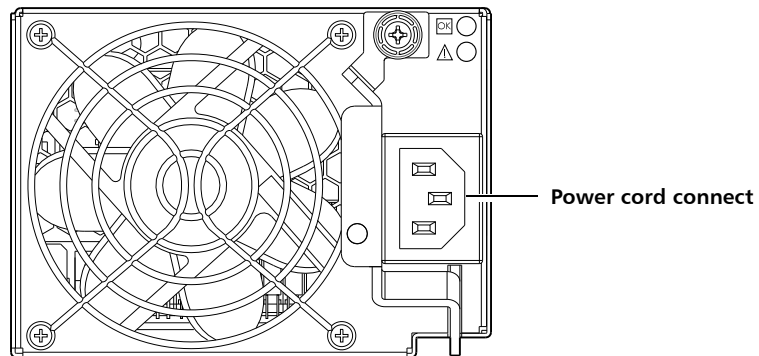

Figure 11 AC PSU

### To power on the system:

- 1 Plug the power cord into the power cord connector on the rear of the drive enclosure. Plug the other end of the power cord into the rack power source (see [Figure 11](#) and [Figure 12](#)). Wait several seconds to allow the disks to spin up.

Repeat this sequence for each switchless PSU within each drive enclosure.

- 2 Plug the power cord into the power cord connector on the rear of the controller enclosure. Plug the other end of the power cord into the rack power source (see [Figure 11](#) and [Figure 12](#)).

Repeat the sequence for the controller enclosure's other switchless PSU.

Power cord facilitates power on/power off

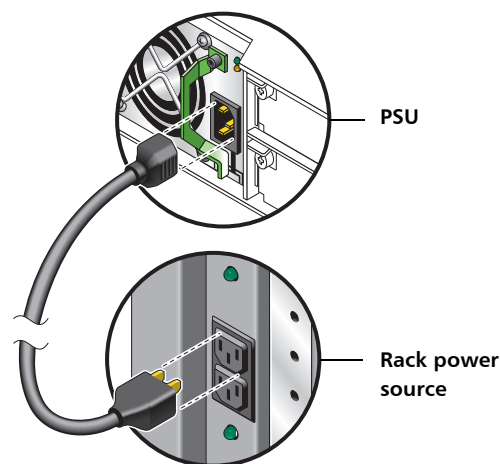

Figure 12 AC power cord

### To power off the system:

- 1 Stop all I/O from hosts to the system (see [Stopping I/O](#) on page 37).
- 2 Shut down both controllers using *either* method described below:
  - Use the Quantum StorNext Disk Storage Management Utility to shut down both controllers, as described in the *StorNext QX Storage Disk Storage Management Utility Users Guide*. Proceed to [step 3](#).
  - Use the CLI to shut down both controllers, as described in the *StorNext QX Storage CLI Reference Guide*.
- 3 Disconnect the power cord's male plug from the power source.
- 4 Disconnect the power cord's female plug from the power cord connector on the PSU.

## DC and AC PSUs with power switch

DC and legacy AC power supplies, each equipped with a power switch, are shown below.

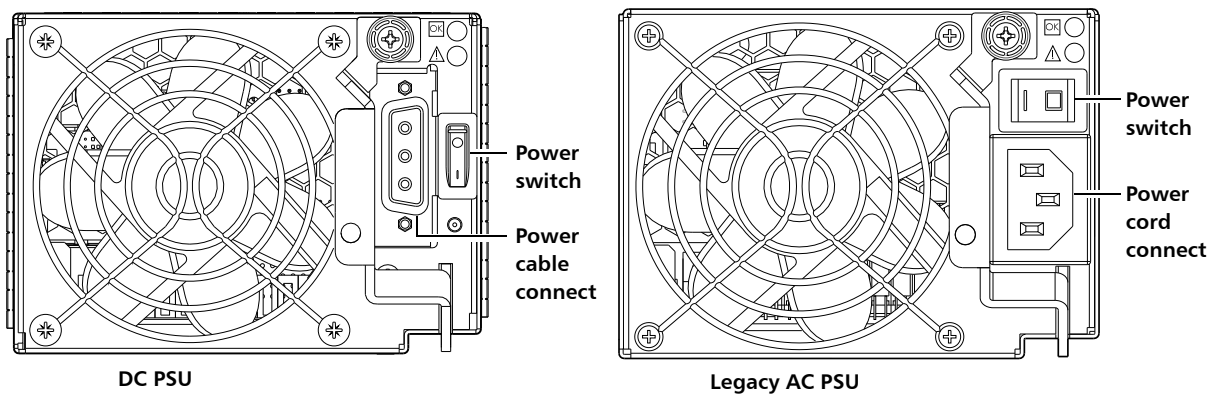

Figure 13 DC and AC PSUs with power switch

## Power Cords

---

 **IMPORTANT:** See [Environmental requirements and specifications](#) for additional information.

---

### AC model

See [Figure 12](#) and [Figure 13](#) (right) when performing the following steps:

- 1 Verify that the enclosure's power switches are in the Off position.
- 2 Identify the power cord connector on the PSU, and locate the target power source.
- 3 Using the AC power cords provided, plug one end of the cord into the power cord connector on the PSU. Plug the other end of the power cord into the rack power source.
- 4 Verify connection of primary power cords from the rack to separate external power sources.

See [Power cycle](#) on page 17.

## DC model

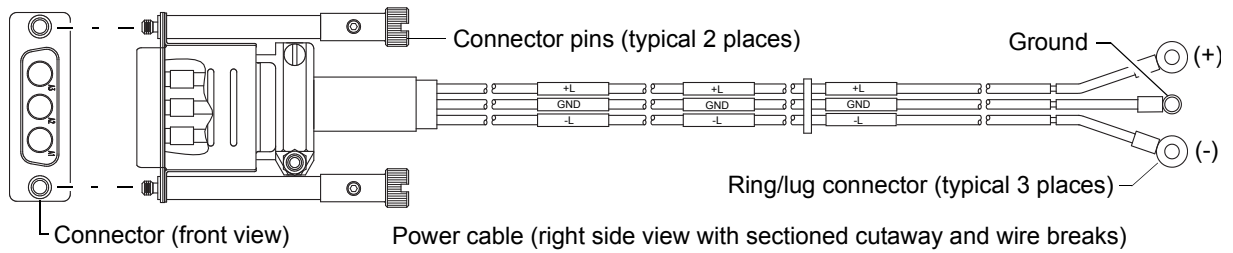
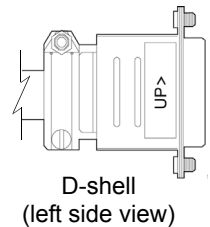

Figure 14 DC power cable featuring D-shell and lug connectors

See [Figure 14](#) and [Figure 13](#) (left) when performing the following steps:

- 1 Locate and use the provided DC power cables.
- 2 Verify that the enclosure's power switches are in the Off position.
- 3 Connect a DC power cable to each DC PSU using the D-shell connector. Use the UP> arrow on the connector shell to ensure proper positioning (see adjacent left side view of D-shell connector).
- 4 Tighten the screws at the top and bottom of the shell, applying a torque between 1.7 N-m (15 in-lb) and 2.3 N-m (20 in-lb), to securely attach the cable to the DC PSU.
- 5 To complete the DC connection, secure the other end of each cable wire component of the DC power cable to the target DC power source.



Check the three individual DC cable wire labels before connecting each cable wire lug to its power source. One cable wire is labeled *ground* (GND), and the other two are labeled *positive* (+L) and *negative* (-L) (shown in [Figure 14](#)).

---

△ **CAUTION:** Connecting to a DC power source outside the designated -48VDC nominal range (-36VDC to -72VDC) may damage the enclosure.

---

See [Power cycle](#) on page 17.

### Power cycle

#### To power on the system:

- 1 Power up drive enclosure(s) by pressing the power switches at the rear of each drive enclosure to the **On** position. Allow several seconds for disks to spin up.
- 2 Power up the controller enclosure next by pressing the power switches at the rear of the controller enclosure to the **On** position.

#### To power off the system:

- 1 Stop all I/O from hosts to the system (see [Stopping I/O](#) on page 37).
- 2 Shut down both controllers using *either* method described below:
  - Use the Quantum StorNext Disk Storage Management Utility to shut down both controllers, as described in the *StorNext QX Storage Disk Storage Management Utility Users Guide*. Proceed to [step 3](#).
  - Use the CLI to shut down both controllers, as described in the *StorNext QX Storage CLI Reference Guide*.
- 3 Press the power switches at the rear of the controller enclosure to the Off position.
- 4 Press the power switches at the rear of each drive enclosure to the Off position.







## Chapter 3

# Connecting hosts

---

---

### Host system requirements

Depending on your system configuration, host operating systems may require that multipathing is supported.

If fault tolerance is required, then multipathing software may be required. Host-based multipath software should be used in any configuration where two logical paths between the host and any storage volume may exist at the same time. This would include most configurations where there are multiple connections to the host or multiple connections between a switch and the storage.

---

### Cabling considerations

Common cabling configurations address hosts, controller enclosures, drive enclosures, and switches. Host interface ports on StorNext QX Storage controller enclosures can connect to respective hosts via direct-attach or switch-attach.

---

### Connecting the enclosure to hosts

A *host* identifies an external port to which the storage system is attached. Cable connections vary depending on configuration. This section describes host interface protocols supported by StorNext QX Storage controller enclosures, while showing a few common cabling configurations.

---

 **NOTE:** The StorNext QX Storage controllers use ULP, a controller feature enabling a host to access mapped volumes through any controller host port.

---

ULP can show all LUNs through all host ports on both controllers, and the interconnect information is managed by the controller firmware. ULP appears to the host as an active-active storage system, allowing the host to select any available path to access the LUN, regardless of vdisk ownership.

---

**TIP:** See “Configuring the system > Using the Configuration Wizard” in the *StorNext QX Storage Disk Storage Management Utility Users Guide* to initially configure the system or change system configuration settings (for example, Configuring host ports).

---

## FC host ports

Certain StorNext QX Storage controller enclosures use FC interface protocol for host port connection, featuring two controller modules. Each controller module provides host ports configured with an FC SFP transceiver connector, supporting data rates up to 8 Gbit/s.

The StorNext QX-2400 / StorNext QX-1200 models support FC-AL (loop) or point-to-point topologies. Loop protocol can be used in a physical loop or in a direct connection between two devices. Point-to-point protocol is used to connect to a fabric switch. These models employ FC ports for attachment to FC hosts directly, or through an FC switch, which requires that the host computer supports Ethernet, FC, and optionally, multipath I/O.

---

**TIP:** Use the Quantum StorNext Disk Storage Management Utility’s Configuration Wizard to set FC port options.

---

## Connecting direct attach configurations

The StorNext QX-2400 / StorNext QX-1200 each support up to eight direct-connect server connections, four per controller module. Connect appropriate cables from the server’s HBAs to the controller module’s host ports as described below, and shown in [Figure 15](#) through [Figure 16](#).

- To connect the StorNext QX-2400 / StorNext QX-1200 controller enclosure to a server HBA or switch using the controller’s FC host ports, select FC cables supporting 2/4/8 Gbit data rates, that are compatible with the controller module’s host port SFP connector. The table below maps SFP transceiver data rates to relative fiber optic cable characteristics (i.e., cable length, MMF, and ISO/IEC optical multimode cable performance standards). When transferring data through FC connections, cable lengths should not exceed the lengths listed for each given fiber type and performance code within the applicable data rate (2/4/8 Gbit) class.

**Table 5** Maximum cable lengths for 850nm FC SFP transceivers

SFP data	Representative FC cable types	Cable performance code		
		OM1	OM2	OM3
Data rate	MMF FC cable length designators			
8 Gbit/s	21m with 62.5µm fiber type	X		
	50m with 50µm fiber type		X	
	150m with 50µm fiber type			X
4 Gbit/s	70m with 62.5µm fiber type	X		
	150m with 50µm fiber type		X	
	380m with 50µm fiber type			X
2 Gbit/s	150m with 62.5µm fiber type	X		
	300m with 50µm fiber type		X	
	500m with 50µm fiber type			X

## Dual-controller configurations

**IMPORTANT:** All StorNext QX Storage configurations are dual-controller. Single-controller support is provided only when a controller fails over to its partner controller. A controller module must be installed in each IOM slot to ensure sufficient airflow through the enclosure during operation.

Dual-controller configurations improve application availability because, in the event of a controller failure, the affected controller fails over to the partner controller with little interruption to data flow. A failed controller can be replaced without the need to shut down the storage system.

In a dual-controller system, hosts use LUN-identifying information from both controllers to determine that up to four paths are available to a given storage volume. Assuming MPIO software is installed, a host can use any available data path to access a volume owned by either controller. The path providing the best performance is through host ports on the volume's owning controller. Both controllers share one set of 512 LUNs (0-511) for use in mapping volumes to hosts (see "ULP" in the *StorNext QX Storage Disk Storage Management Utility Users Guide*).

### One server/one HBA/dual path

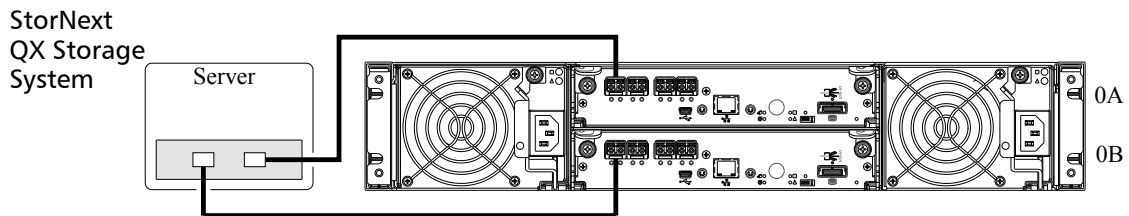

Figure 15 Connecting hosts: One server and one HBA, dual path

### StorNext QX Storage System

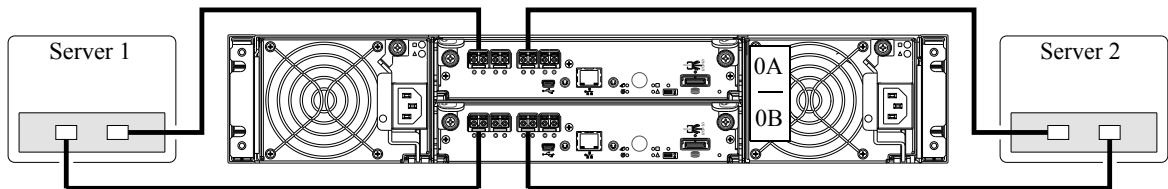

Figure 16 Connecting hosts: Two servers and one HBA per server, dual path

### Four servers and one HBA per server, dual path

Figure 17 shows four-server/dual-controller configurations for StorNext QX Storage controller enclosures supporting pertinent host interface protocols.

StorNext QX Storage System

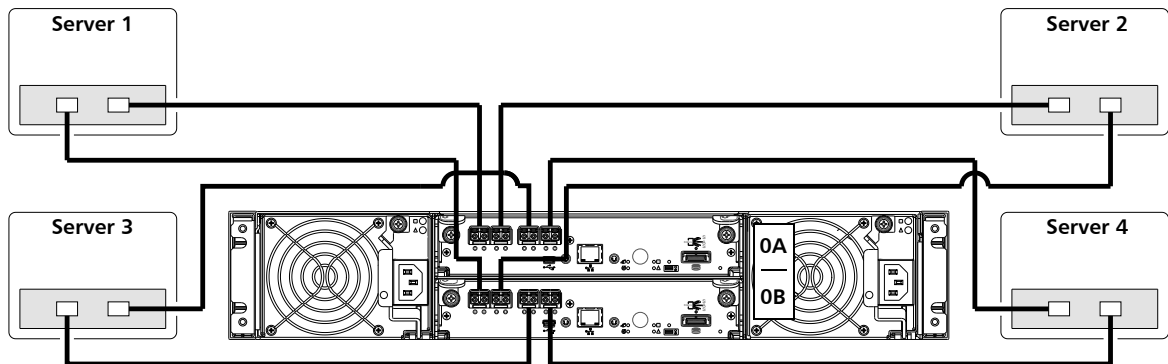

Figure 17 Connecting hosts: Four servers and one HBA per server, dual path

## Connecting switch attach configurations

A SAN places a switch between the servers and the controller enclosures. Using switches, a SAN shares a storage system among multiple servers, reducing the number of storage systems required for a particular environment. Using switches increases the number of servers that can be connected to the storage system. A StorNext QX Storage controller enclosure supports 64 hosts.

### Multiple servers/multiple switches

Model-specific dual-controller illustrations in Figure 18 show switch-connect configurations for StorNext QX Storage controller enclosures supporting pertinent host interface protocols. Connect appropriate cables from controller host ports to switch ports, and from switch ports to hosts. It is important to have a least one port connected from each switch to each controller module to provide redundancy.

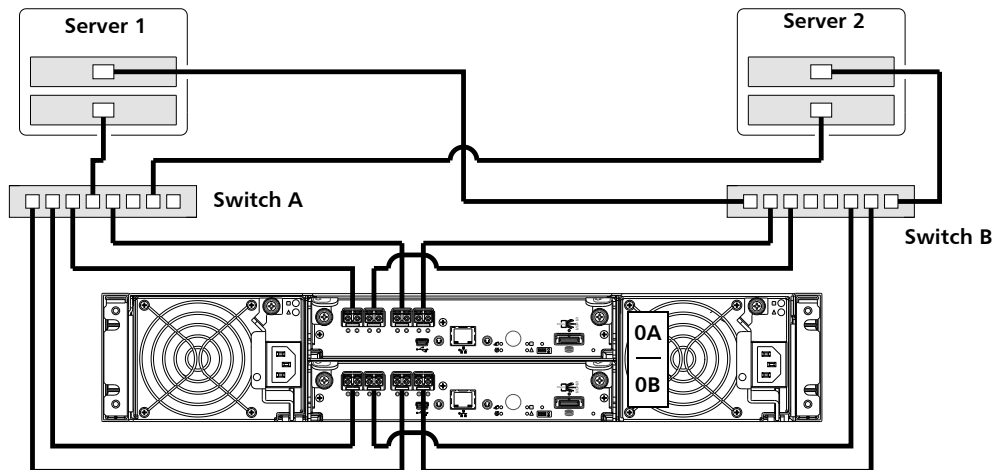

Figure 18 Connecting hosts: Switch attach: multiple servers/switches

---

## Connecting a management host on the network

The management host directly manages storage systems out-of-band over an Ethernet network.

- 1 Connect an RJ-45 Ethernet cable to the network port on each controller.
- 2 Connect the other end of each Ethernet cable to a network that your management host can access (preferably on the same subnet).

---

 **NOTE:** Connections to this device must be made with shielded cables grounded at both ends with metallic RFI/EMI connector hoods in order to maintain compliance with NEBS and FCC Rules and Regulations, see the *Quantum Product Regulatory Compliance and Safety* document.

---

---

## Updating Firmware

After installing the hardware and powering on the storage system components for the first time, verify that the controller modules, expansion modules, and disk drives are using the current firmware release. Using the Quantum StorNext Disk Storage Management Utility, right-click the system in the Configuration View panel, and select **Tools > Update Firmware**. The Update Firmware panel displays the currently installed firmware versions and allows you to update them. Optionally, you can update firmware using FTP as described in the *StorNext QX Storage CLI Reference Guide* or *StorNext QX Storage Disk Storage Management Utility Users Guide*.

---

## Obtaining IP values

You can configure addressing parameters for each controller module's network port. You can set static IP values or use DHCP.

---

 **TIP:** See the "Configuring network ports" topic in the *StorNext QX Storage Disk Storage Management Utility Users Guide*.

---

## Setting network port IP addresses using DHCP

In DHCP mode, network port IP address, subnet mask, and gateway values are obtained from a DHCP server if one is available. If a DHCP server is unavailable, current addressing is unchanged. You must have a means of determining what addresses have been assigned, such as the list of bindings on the DHCP server.

Because DHCP is disabled by default in StorNext QX Storage systems, you must either use the CLI to change controller IP address settings or use Quantum StorNext Disk Storage Management Utility's Configuration Wizard as described in the Using the Configuration Wizard topic in the *StorNext QX Storage Disk Storage Management Utility Users Guide*.

## Setting network port IP addresses using the CLI

If you did not use DHCP to set network port IP values, set them manually (default method) as described below. If you are using the USB CLI port and cable, you will need to enable the port for communication.

Network ports on controller module A and controller module B are configured with the following default values:

- Network port IP address: 10.0.0.2 (controller A), 10.0.0.3 (controller B)
- IP subnet mask: 255.255.255.0
- Gateway IP address: 10.0.0.1

If the default IP addresses are not compatible with your network, you must set an IP address for each network port using the CLI embedded in each controller module. The CLI enables you to access the system using the USB communication interface and terminal emulation software.

---

**NOTE:** If you are using the mini-USB CLI port and cable, see Appendix D, [USB device connection](#):

- Windows customers should download and install the device driver as described in [Microsoft Windows](#) on page 71.
  - Linux customers should prepare the USB port as described in [Setting parameters for the device driver](#) on page 71.
- 

Use the CLI commands described in the steps below to set the IP address for the network port on each controller module.

Once new IP addresses are set, you can change them as needed using the Quantum StorNext Disk Storage Management Utility. Be sure to change the IP address via the Disk Storage Management Utility before changing the network configuration. See [Quantum StorNext Disk Storage Management Utility](#) on page 30 for more information concerning the Disk Storage Management Utility.

- 1 From your network administrator, obtain an IP address, subnet mask, and gateway address for controller A and another for controller B.

Record these IP addresses so you can specify them whenever you manage the controllers using the Quantum StorNext Disk Storage Management Utility or the CLI.

- 2 Use the provided USB cable to connect controller A to a USB port on a host computer. The USB mini 5 male connector plugs into the CLI port as shown in [Figure 19](#) (generic StorNext QX Storage controller module shown).

Connect USB cable to CLI port on controller face plate

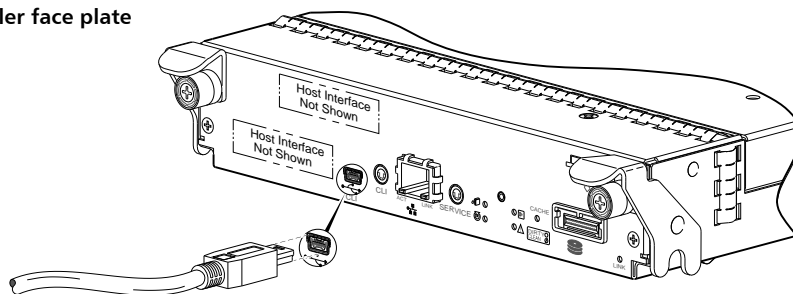

**Figure 19** Connecting a USB cable to the CLI port

- 3 Enable the CLI port for subsequent communication:
  - Linux customers should enter the command syntax provided in [Setting parameters for the device driver](#) on page 71.
  - Windows customers should locate the downloaded device driver described in [Microsoft Windows](#) on page 71.
- 4 Start and configure a terminal emulator, such as HyperTerminal or VT-100, using the display settings in [Table 6](#) and the connection settings in [Table 7](#).  
See the [Using HyperTerminal with the CLI on a Microsoft Windows host](#): on page 26.

**Table 6** Terminal emulator display settings

Parameter	Value
Terminal emulation mode	VT-100 or ANSI (for color support)
Font	Terminal
Translations	None
Columns	80

**Table 7** Terminal emulator connection settings

Parameter	Value
Connector	COM3 (for example) <sup>1,2</sup>
Baud rate	115,200
Data bits	8
Parity	None
Stop bits	1
Flow control	None

<sup>1</sup>Your server or laptop configuration determines which COM port is used for Disk Array USB Port.

<sup>2</sup>Verify the appropriate COM port for use with the CLI.

- 5 In the terminal emulator, connect to controller A.
- 6 Press **Enter** to display the CLI prompt (#).  
The CLI displays the system version, MC version, and login prompt:
  - a At the login prompt, enter the default user `manage` and press **Enter**.
  - b At the password prompt, enter the default password `!manage` and press **Enter**.
 If the default user name, password, or both have been changed for security reasons, enter the secure login credentials instead of the defaults.

- 7 At the prompt, enter the following command to set the values you obtained in [step 1](#) for each Network port, first for controller A, and then for controller B:

```
set network-parameters ip address netmask netmask gateway gateway controller
a|b
```

where:

- *address* is the IP address of the controller
- *netmask* is the subnet mask
- *gateway* is the IP address of the subnet router
- a|b specifies the controller whose network parameters you are setting

For example:

```
# set network-parameters ip 192.168.0.10 netmask 255.255.255.0 gateway
192.168.0.1 controller a
```

```
# set network-parameters ip 192.168.0.11 netmask 255.255.255.0 gateway
192.168.0.1 controller b
```

- 8 Enter the following command to verify the new IP addresses:

```
show network-parameters
```

Network parameters, including the IP address, subnet mask, and gateway address, are displayed for each controller.

- 9 Use the ping command to verify connectivity to the gateway address.

For example:

```
# ping 192.168.0.1
```

```
Info: Pinging 192.168.0.1 with 4 packets.
```

```
Success: Command completed successfully. - The remote computer responded with
4 packets.(2011-12-19 10:20:37)
```

- 10 In the host computer's command window, type the following command to verify connectivity, first for controller A and then for controller B:

```
ping controller-IP-address
```

If you cannot access your system for at least three minutes after changing the IP address, you might need to restart the MC(s) using the serial CLI.

When you restart an MC, communication with it is temporarily lost until it successfully restarts.

Enter the following command to restart the MC in both controllers:

- 11 When you are done using the CLI, exit the emulator.

- 12 Retain the IP addresses (recorded in step 1) for accessing and managing the controllers using either the Quantum StorNext Disk Storage Management Utility or the CLI.

---

 **NOTE:** Using HyperTerminal with the CLI on a Microsoft Windows host:

On a host computer connected to a controller module's mini-USB CLI port, incorrect command syntax in a HyperTerminal session can cause the CLI to hang. To avoid this problem, use correct syntax, use a different terminal emulator, or connect to the CLI using Telnet rather than the mini-USB cable.

Be sure to close the HyperTerminal session before shutting down the controller or restarting its MC. Otherwise, the host's CPU cycles may rise unacceptably.

---



If communication with the CLI is disrupted when using an out-of-band cable connection, communication can sometimes be restored by disconnecting and reattaching the mini-USB CLI cable as described in [step 2](#) and [Figure 19](#) on page 24.





## Chapter 4

# Basic operation

---

Verify that you have successfully completed the sequential “Installation Checklist” instructions in [Table 3](#) on page 7. Once you have successfully completed steps 1 through 8, you can access the management interfaces to complete the system setup.

This provides a brief introduction to the CLI and the Quantum StorNext Disk Storage Management Utility. For more information, see the *StorNext QX Storage CLI Reference Guide* and *StorNext QX Storage Disk Storage Management Utility Users Guide*.

---

## CLI

The CLI software embedded in the controller modules enables you to manage and monitor storage-system operation.

### Signing in to the CLI

- 1 Access the CLI using one of the following options:
  - Use HTTP, HTTPS, Telnet, an SSH application, or a terminal emulator on a management host that is remotely connected through a LAN to a controller module’s network port. See the *StorNext QX Storage Setup Guide* for information about setting management port IP addresses using the CLI.
  - By using a terminal emulator on a management host that is directly connected to a controller module’s serial CLI port.
- 2 When prompted with `login`, enter the user name and press **Enter**. The default user name is `manage`.
- 3 When prompted with `password`, enter the password and press **Enter**. The default password is `!manage`.

If you are logging in to the CLI for the first time, the Language field displays `user setting` or `English`, either of which results in English.

---

# Quantum StorNext Disk Storage Management Utility

The Quantum StorNext Disk Storage Management Utility is a web-based application for configuring, monitoring, and managing the storage system.

Each controller module in the storage system contains a web server, which is accessed when you sign in to this utility. In a dual-controller system, you can access all functions from either controller. If one controller becomes unavailable, you can continue to manage the storage system from the partner controller.

The Quantum StorNext Disk Storage Management Utility is also referred to as the *WBI*.

## Browser setup

- Use Mozilla Firefox 3 or later, or Microsoft Internet Explorer 8 or later.
- To see the help window, you must enable pop-up windows.
- To optimize the display, use a color monitor and set its color quality to the highest setting.
- To navigate beyond the Sign In page (with a valid user account):
  - Set the browser's local-intranet security option to medium or medium-low. For Internet Explorer 8, adding each controller's network IP address as a trusted site can avoid access issues.
  - Verify that the browser is set to allow cookies at least for the IP addresses of the storage-system network ports.

## Signing in to the Quantum StorNext Disk Storage Management Utility

- 1 In the web browser's address field, type the IP address of a controller network port and press **Enter**. The Quantum StorNext Disk Storage Management Utility Sign In page is displayed. If the Sign In page does not display, verify that you have entered the correct IP address.
- 2 On the Sign In page, enter the name and password of a configured user. The default user name and password are `manage` and `!manage`. If you are logging in to the Disk Storage Management Utility for the first time, the Language field displays `user setting` or `English`, either of which results in English.
- 3 Click **Sign In**. If the system is available, the System Overview page is displayed; otherwise, a message indicates that the system is unavailable.

### Tips for signing in and signing out

- Do not include a leading zero in an IP address. For example, enter 10.1.4.6 not 10.1.4.06.
- Multiple users can be signed in to each controller simultaneously.
- For each active Disk Storage Management Utility session, an identifier is stored in the browser. Depending on how your browser treats this session identifier, you might be able to run multiple independent sessions simultaneously. Internet Explorer can run separate Disk Storage Management Utility sessions if you select `New Session` in the File menu. If you do not select this then all instances of Internet Explorer share the same session, as does Firefox.

You can end a Disk Storage Management Utility session by clicking the Sign Out link near the top of the Disk Storage Management Utility window. Do not simply close the browser window.

## Configuring and provisioning the storage system

Once you have familiarized yourself with the Quantum StorNext Disk Storage Management Utility, use it to configure and provision the storage system. Refer to the following chapters within the *StorNext QX Storage Disk Storage Management Utility Users Guide*:

- Getting started
- Configuring the system
- Provisioning the system

---

 **IMPORTANT:** If the system is used in a VMware environment, set the system's Missing LUN Response option to use its Illegal Request setting. To do so, see either the configuration topic "Changing the missing LUN response" in the *StorNext QX Storage Disk Storage Management Utility Users Guide* or the command topic "set-advanced-settings" in the *StorNext QX Storage CLI Reference Guide*.

---

---

## Best practices for optimal performance

Table 8 lists features that can negatively impact performance on your system and recommendations for minimizing the impact.

For more information on an item, see either the *StorNext QX Storage CLI Reference Guide* or the *StorNext QX Storage Disk Storage Management Utility Users Guide*.

**Table 8** Solutions to degraded performance

Feature	Impact	Recommendations for minimizing impact
Managed logs	The managed logs function collects information at least once every 12 hours. While collecting information, the system might experience increased I/O response time and/or I/O time-outs.	Disable managed logs through Quantum StorNext Disk Storage Management Utility or the CLI.
Active Quantum StorNext Disk Storage Management Utility, CLI, SMI-S, and SNMP sessions	Active Quantum StorNext Disk Storage Management Utility, CLI, SMI-S, and SNMP sessions collect information up to 4 times per hour. While collecting information, the system might experience increased I/O response time and/or I/O time-outs.   <b>NOTE:</b> Use of SMI-S and SNMP traps does not affect performance.	Use the Quantum StorNext Disk Storage Management Utility, the CLI, SMI-S, and SNMP during non-peak hours.

**Table 8** Solutions to degraded performance (continued)

Feature	Impact	Recommendations for minimizing impact
Background and manual scrubs	<ul style="list-style-type: none"> <li>• A background scrub affects performance up to 5%.</li> <li>• A manual scrub affects performance 25 - 60%.</li> </ul>	<ul style="list-style-type: none"> <li>• Disable background scrubs through the Quantum StorNext Disk Storage Management Utility or the CLI.</li> </ul> <hr/> <p>△ <b>CAUTION:</b> If you disable background scrubs, run a manual scrub at least once per month.</p> <hr/> <ul style="list-style-type: none"> <li>• Run a manual scrub during non-peak hours.</li> <li>• Set the Utility priority for manual scrubs to low through the Quantum StorNext Disk Storage Management Utility or the CLI.</li> </ul>
Reconstruction and copyback	<ul style="list-style-type: none"> <li>• Reconstruction affects performance 5 - 50%.</li> <li>• Copyback affects performance up to 15%.</li> </ul>	<ul style="list-style-type: none"> <li>• Set the Utility priority for reconstruction to low through the Quantum StorNext Disk Storage Management Utility or the CLI.</li> <li>• Replace failed disks during non-peak hours</li> </ul> <hr/> <p>△ <b>CAUTION:</b> It is recommended that failed disks are replaced immediately.</p> <hr/>



## Chapter 5

# Troubleshooting

---

---

## USB CLI port connection

Quantum StorNext QX Storage controllers feature a CLI port employing a mini-USB Type B form factor. If you encounter problems communicating with the port after cabling your computer to the USB device, you may need to either download a device driver (Windows), or set appropriate parameters via an operating system command (Linux). See [USB device connection](#) for more information.

---

## Fault isolation methodology

Quantum StorNext QX Storage storage systems provide many ways to isolate faults. This section presents the basic methodology used to locate faults within a storage system, and to identify the pertinent FRUs affected.

As noted in [Basic operation](#) on page 29, configure and provision the system upon completing the hardware installation. As part of this process, configure and enable event notification so the system will notify you when a problem occurs that is at or above the configured severity (see “Using the Configuration Wizard > Configuring event notification” in the *StorNext QX Storage Disk Storage Management Utility Users Guide*). With event notification configured and enabled, you can follow the recommended actions in the notification message to resolve the problem, as further discussed in the options presented below.

### Basic steps

The basic fault isolation steps are listed below:

- Gather fault information, including using system LEDs. See [Gather fault information](#) on page 35.
- Determine where in the system the fault is occurring. See [Determine where the fault is occurring](#) on page 35.
- Review event logs. See [Review the event logs](#) on page 35.
- If required, isolate the fault to a data path component or configuration. See [Isolate the fault](#) on page 35.

## Options available for performing basic steps

When performing fault isolation and troubleshooting steps, select the option or options that best suit your site environment. Four options are described below. Use of any option is not mutually-exclusive to the use of another option. You can use the Quantum StorNext Disk Storage Management Utility to check the health icons/values for the system and its components to ensure that everything is okay, or to view a problem component. If you discover a problem, both the Quantum StorNext Disk Storage Management Utility and the CLI provide recommended-action text. Options for performing basic steps are listed according to frequency of use:

- [Use the Quantum StorNext Disk Storage Management Utility](#)
- [Use the CLI](#)
- [Monitor event notification](#)
- [View the enclosure LEDs](#)

### Use the Quantum StorNext Disk Storage Management Utility

The Quantum StorNext Disk Storage Management Utility uses health icons to show OK, Degraded, Fault, or Unknown status for the system and its components. The Disk Storage Management Utility enables you to monitor the health of the system and its components. If any component has a problem, the system health will be Degraded, Fault, or Unknown. Use the Disk Storage Management Utility's GUI to find each component that has a problem, and follow actions in the component Health Recommendations field to resolve the problem.

### Use the CLI

As an alternative to using the Disk Storage Management Utility, you can run the `show system` command in the CLI to view the health of the system and its components. If any component has a problem, the system health will be Degraded, Fault, or Unknown, and those components will be listed as Unhealthy Components. Follow the recommended actions in the component Health Recommendation field to resolve the problem.

### Monitor event notification

With event notification configured and enabled, you can view event logs to monitor the health of the system and its components. If a message tells you to check whether an event has been logged, or to view information about an event in the log, you can do so using either the Disk Storage Management Utility or the CLI. Using the Disk Storage Management Utility, you view the event log and then click on the event message to see detail about that event. Using the CLI, you run the `show events detail` command (with additional parameters to filter the output) to see the detail for an event. The events will be listed in reverse chronological order (most recent messages are at the top of the list). The Disk Storage Management Utility will only display the last 100 events.

### View the enclosure LEDs

You can view the LEDs on the hardware (while referring to [LED descriptions](#) for your enclosure model) to identify component status. If a problem prevents access to either the Disk Storage Management Utility or the CLI, this is the only option available. However, monitoring/management is often done at a management console using storage management interfaces rather than relying on line-of-sight to LEDs of racked hardware components.

## Performing basic steps

You can use any of the available options described above in performing the basic steps comprising the fault isolation methodology.



## Gather fault information

When a fault occurs, it is important to gather as much information as possible. Doing so will help you determine the correct action needed to remedy the fault.

Begin by reviewing the reported fault:

- Is the fault related to an internal data path or an external data path?
- Is the fault related to a hardware component such as a disk drive module, controller module, or PSU?

By isolating the fault to one of the components within the storage system, you will be able to determine the necessary corrective action more quickly.

## Determine where the fault is occurring

Once you have an understanding of the reported fault, review the enclosure LEDs. The enclosure LEDs are designed to immediately alert users of any system faults, and might be what alerted the user to a fault in the first place.

When a fault occurs, the Fault ID Status LED on an enclosure's right ear illuminates (see the diagram pertaining to your product's front panel components on page 1). Check the LEDs on the rear of the enclosure to narrow the fault to a FRU, connection, or both. The LEDs also help you identify the location of a FRU reporting a fault.

Use the Quantum StorNext Disk Storage Management Utility to verify any faults found while viewing the LEDs. The Disk Storage Management Utility is also useful in determining where the fault is occurring if the LEDs cannot be viewed due to the location of the system. It provides you with a visual representation of the system and where the fault is occurring. It can also provide more detailed information about FRUs, data, and faults.

## Review the event logs

The event logs record all system events. Each event has a numeric code that identifies the type of event that occurred, and has one of the following severities:

- **Critical.** A failure occurred that may cause a controller to shut down. Correct the problem *immediately*.
- **Error.** A failure occurred that may affect data integrity or system stability. Correct the problem as soon as possible.
- **Warning.** A problem occurred that may affect system stability, but not data integrity. Evaluate the problem and correct it if necessary.
- **Informational.** A configuration or state change occurred, or a problem occurred that the system corrected. No immediate action is required.

See the *StorNext QX Storage Service Guide*, which is available at [www.quantum.com](http://www.quantum.com), for information about specific events.

It is very important to review the logs, not only to identify the fault, but also to search for events that might have caused the fault to occur. For example, a host could lose connectivity to a vdisk if a user changes channel settings without taking the storage resources assigned to it into consideration. In addition, the type of fault can help you isolate the problem to either hardware or software.

## Isolate the fault

Occasionally, it might become necessary to isolate a fault. This is particularly true with data paths, due to the number of components comprising the data path. For example, if a host-side data error occurs, it could be caused by any of the components in the data path: controller module, cable, or data host.

## If the enclosure does not initialize

It may take up to two minutes for all enclosures to initialize. If an enclosure does not initialize:

- Perform a rescan
- Power cycle the system
- Make sure the power cord is properly connected, and check the power source to which it is connected
- Check all cable connections from controller and drive enclosures
- Check the event log for errors

## Correcting enclosure IDs

When installing a system with drive enclosures attached, the enclosure IDs might not agree with the physical cabling order. This is because the controller might have been previously attached to enclosures in a different configuration, and it attempts to preserve the previous enclosure IDs if possible. To correct this condition, make sure that both controllers are up, and perform a rescan using the Disk Storage Management Utility or the CLI. This will reorder the enclosures, but can take up to two minutes for the enclosure IDs to be corrected.

To perform a rescan using the CLI, type the following command:

```
rescan
```

To rescan using the Disk Storage Management Utility:

- 1 Verify that controllers are operating normally
- 2 In the Configuration View panel, right-click the system and select **Tools > Rescan Disk Channels**
- 3 Click **Rescan**.

---

# Stopping I/O

When troubleshooting disk and connectivity faults, ensure you have a current full backup. As an additional data protection precaution, stop all I/O to the affected vdisks.

---

 **IMPORTANT:** Stopping I/O to a vdisk is a host-side task, and falls outside the scope of this document.

---

When on-site, you can verify that there is no I/O activity by briefly monitoring the system LEDs; however, when accessing the storage system remotely, this is not possible. Remotely, you can use the `show vdisk-statistics` command to determine if I/O has stopped. Perform the steps below:

Using the CLI, run the `show vdisk-statistics` command.

The **Number of Reads** and **Number of Writes** outputs show the number of these operations that have occurred since the statistic was last requested. Record the numbers displayed.

4 Run the `show vdisk-statistics` command a second time.

This provides you a specific window of time (the interval between requesting the statistics) to determine if data is being written to or read from the disk. Record the numbers displayed.

5 To determine if any reads or writes occur during this interval, subtract the set of numbers you recorded in [step 3](#) from the numbers you recorded in [step 4](#).

- If the resulting difference is zero, I/O has stopped.
- If the resulting difference is not zero, a host is still reading from or writing to this vdisk. Continue to stop I/O from hosts, and repeat [step 3](#) and [step 4](#) until the difference in [step 5](#) is zero.

---

 **NOTE:** See the *StorNext QX Storage CLI Reference Guide* for additional information.

---

---

## Diagnostic steps

This section describes possible reasons and actions to take when an LED indicates a fault condition during initial system setup. See [LED descriptions](#) for descriptions of all LED statuses.

In addition to monitoring LEDs via line-of-sight observation of the racked hardware components when performing diagnostic steps, you can also monitor the health of the system and its components using the management interfaces previously discussed. Bear this in mind when reviewing the **Actions** column in the following diagnostics tables, and when reviewing the step procedures provided later in this chapter.

## Is the enclosure front panel “Fault/Service Required” LED amber?

**Table 9** Diagnostics LED status: Front panel “Fault/Service Required”

Answer	Possible reasons	Actions
No	System functioning properly.	No action required.
Yes	<p>A fault condition exists/occurred.</p> <p>If installing an IOM FRU, the module has gone online and likely failed its self-test.</p>	<ul style="list-style-type: none"> <li>• Check the LEDs on the rear of the controller to narrow the fault to a FRU, connection, or both.</li> <li>• Check the event log for specific information regarding the fault; follow any Recommended Actions.</li> <li>• If installing an IOM FRU, try removing and reinstalling the new IOM, and check the event log for errors.</li> <li>• If the above actions do not resolve the fault, isolate the fault and contact an authorized service provider for assistance. Replacement may be necessary.</li> </ul>

## Is the controller rear panel “FRU OK” LED lit?

**Table 10** Diagnostics LED status: Rear panel “FRU OK”

Answer	Possible reasons	Actions
Yes (blinking)	System functioning properly. System is booting.	No action required. Wait for system to boot.
No	<p>The controller module is not powered on.</p> <p>The controller module has failed.</p>	<ul style="list-style-type: none"> <li>• Check that the controller module is fully inserted and latched in place, and that the enclosure is powered on.</li> <li>• Check the event log for specific information regarding the failure.</li> </ul>

## Is the controller rear panel “Fault/Service Required” LED amber?

**Table 11** Diagnostics LED status: Rear panel “Fault/Service Required”

Answer	Possible reasons	Actions
No	System functioning properly.	No action required.
Yes (blinking)	<p>One of the following errors occurred:</p> <ul style="list-style-type: none"> <li>• Hardware-controlled power-up error</li> <li>• Cache flush error</li> <li>• Cache self-refresh error</li> </ul>	<ul style="list-style-type: none"> <li>• Restart this controller from the other controller using the <i>Quantum StorNext Disk Storage Management Utility</i> or the CLI.</li> <li>• If the above action does not resolve the fault, remove the controller and reinsert it.</li> <li>• If the above action does not resolve the fault, contact an authorized service provider for assistance. It may be necessary to replace the controller.</li> </ul>

## Are both disk drive module LEDs off?

**Table 12** Diagnostic LED status: Disk drive module

Answer	Possible reasons	Actions
Yes	<ul style="list-style-type: none"> <li>• There is no power</li> <li>• The disk is offline</li> </ul>	Check that the disk is fully inserted and latched in place, and that the enclosure is powered on.

## Is the disk drive module “Fault” LED amber?

**Table 13** Diagnostics LED status: Disk drive “Fault” LED (LFF and SFF modules)

Answer	Possible reasons	Actions
Yes, and the online/activity LED is off.	The disk is offline. An event message may have been received for this device.	<ul style="list-style-type: none"> <li>• Check the event log for specific information regarding the fault.</li> <li>• Isolate the fault.</li> <li>• Contact an authorized service provider for assistance.</li> </ul>
Yes, and the online/activity LED is blinking.	The disk is active, but an event message may have been received for this device.	<ul style="list-style-type: none"> <li>• Check the event log for specific information regarding the fault.</li> <li>• Isolate the fault.</li> <li>• Contact an authorized service provider for assistance.</li> </ul>

## Is a connected host port’s “Host Link Status” LED lit?

**Table 14** Diagnostics LED status: Rear panel “Host Link Status”

Answer	Possible reasons	Actions
Yes	System functioning properly.	No action required (see Link LED note: page 55).
No	The link is down.	<p>See also <a href="#">Isolating a host-side connection fault</a> on page 42.</p> <ul style="list-style-type: none"> <li>• Check cable connections and reseal if necessary.</li> <li>• If the above action does not resolve the fault, inspect cable for damage. Replace cable if necessary.</li> <li>• If the above action does not resolve the fault, swap cables to determine if fault is caused by a defective cable. Replace cable if necessary.</li> <li>• If the above action does not resolve the fault, verify that the switch, if any, is operating properly. If possible, test with another port.</li> <li>• If the above action does not resolve the fault, verify that the HBA is fully seated, and that the PCI slot is powered on and operational.</li> <li>• If the above action does not resolve the fault, review event logs for indicators of a specific fault in a host data path component.</li> <li>• If the above action does not resolve the fault, contact an authorized service provider for assistance.</li> </ul>

## Is a connected port's "Expansion Port Status" LED lit?

**Table 15** Diagnostics LED status: Rear panel "Expansion Port Status"

Answer	Possible reasons	Actions
Yes	System functioning properly.	No action required.
No	The link is down.	<p>See also <a href="#">Isolating a controller module expansion port connection fault</a> on page 43.</p> <ul style="list-style-type: none"> <li>• Check cable connections and reseal if necessary.</li> <li>• If the above action does not resolve the fault, inspect cable for damage. Replace cable if necessary.</li> <li>• If the above action does not resolve the fault, swap cables to determine if fault is caused by a defective cable. Replace cable if necessary.</li> <li>• If the above action does not resolve the fault, verify that the switch, if any, is operating properly. If possible, test with another port.</li> <li>• If the above action does not resolve the fault, verify that the HBA is fully seated, and that the PCI slot is powered on and operational.</li> <li>• If the above action does not resolve the fault, review event logs for indicators of a specific fault in a host data path component.</li> <li>• If the above action does not resolve the fault, contact an authorized service provider for assistance.</li> </ul>

## Is a connected port's "Network Port Link Status" LED lit?

**Table 16** Diagnostics LED status: Rear panel "Network Port Link Status"

Answer	Possible reasons	Actions
Yes	System functioning properly.	No action required.
No	The link is down.	<ul style="list-style-type: none"> <li>• Swap cables between the A and B controllers to isolate the fault.</li> <li>• Use standard networking troubleshooting procedures to isolate faults on the network.</li> </ul>

## Is the PSU's "Input Power Source" LED lit?

**Table 17** Diagnostics LED status: Rear panel PSU "Input Power Source"

Answer	Possible reasons	Actions
Yes	System functioning properly.	No action required.
No	The PSU is not receiving adequate power.	<ul style="list-style-type: none"> <li>• Verify that the power cord is properly connected, and check the power source to which it connects.</li> <li>• If the above action does not resolve the fault, check that the PSU FRU is firmly locked into position.</li> <li>• If the above action does not resolve the fault, check the event log for specific information regarding the fault.</li> <li>• If the above action does not resolve the fault, isolate the fault and contact an authorized service provider for assistance.</li> </ul>

## Is the "Voltage/Fan Fault/Service Required" LED amber?

**Table 18** Diagnostics LED status: Rear panel PSU "Voltage/Fan Fault/Service Required"

Answer	Possible reasons	Actions
No	System functioning properly.	No action required.
Yes	The PSU or a fan is operating at an unacceptable voltage or r/min level, or has failed.	<p>When isolating faults in the PSU, remember that the fans in both modules receive power through a common bus on the midplane, so if a PSU fails, the fans continue to operate normally.</p> <ul style="list-style-type: none"> <li>• Verify that the PSU FRU is firmly locked into position.</li> <li>• If the above action does not resolve the fault, verify that the power cable is connected to a power source.</li> <li>• If the above action does not resolve the fault, verify that the power cable is connected to the enclosure's PSU.</li> <li>• If the above action does not resolve the fault, FRU replacement may be necessary; see the <i>StorNext QX Storage Service Guide</i>.</li> </ul>

---

# Isolating a host-side connection fault

During normal operation, when a controller module host port is connected to a data host, the port's host link status LED and host link activity LED are green. If there is I/O activity, the host activity LED blinks green. If data hosts are having trouble accessing the storage system, and you cannot locate a specific fault or cannot access the event logs, use the following procedure.

This procedure requires scheduled downtime.

---

 **IMPORTANT:** Do not perform more than one step at a time. Changing more than one variable at a time can complicate the troubleshooting process.

---

## Host-side connection troubleshooting featuring FC host ports

The procedure below pertains to StorNext QX Storage controller enclosures employing SFP transceiver connectors in 2/4/8 Gbit FC host interface ports.

- 1 Halt all I/O to the storage system (see [Stopping I/O](#) on page 37).
- 2 Check the host activity LED.  
If there is activity, halt all applications that access the storage system.
- 3 Check the Cache Status LED to verify that the controller's cached data is flushed to the disk drives.
  - Solid – Cache is dirty (contains unwritten data) and is not writing to disk.
  - Blinking – Data is still being written to disk.
  - Off – Cache is clean (no unwritten data).
- 4 Inspect the cable for damage.
- 5 Reseat the SFP and host cable.  
Is the host link status LED on?
  - Yes – Monitor the status to ensure that there is no intermittent error present. If the fault occurs again, clean the connections to ensure that a dirty connector is not interfering with the data path.
  - No – Proceed to the next step.
- 6 Move the SFP and host cable to a port with a known good link status.  
This step isolates the problem to the external data path (SFP, host cable, and host-side devices) or to the controller module port.  
Is the host link status LED on?
  - Yes – You now know that the SFP, host cable, and host-side devices are functioning properly. Return the SFP and cable to the original port. If the link status LED remains off, you have isolated the fault to the controller module's port. Replace the controller module.
  - No – Proceed to the next step.
- 7 Swap the SFP with a known good one.  
Is the host link status LED on?
  - Yes – You have isolated the fault to the SFP. Replace the SFP.
  - No – Proceed to the next step.



- 8 Re-insert the original SFP and swap the cable with a known good one.  
Is the host link status LED on?
  - Yes – You have isolated the fault to the cable. Replace the cable.
  - No – Proceed to the next step.
- 9 Verify that the switch, if any, is operating properly. If possible, test with another port.
- 10 Verify that the HBA is fully seated, and that the PCI slot is powered on and operational.
- 11 Replace the HBA with a known good HBA, or move the host side cable and SFP to a known good HBA.  
Is the host link status LED on?
  - Yes – You have isolated the fault to the HBA. Replace the HBA.
  - No – It is likely that the controller module needs to be replaced.
- 12 Move the cable and SFP back to its original port.  
Is the host link status LED on?
  - No – The controller module's port has failed. Replace the controller module.
  - Yes – Monitor the connection for a period of time. It may be an intermittent problem, which can occur with SFPs, damaged cables, and HBAs.

---

## Isolating a controller module expansion port connection fault

During normal operation, when a controller module's expansion port is connected to a drive enclosure, the expansion port status LED is green. If the connected port's expansion port LED is off, the link is down. Use the following procedure to isolate the fault.

This procedure requires scheduled downtime.



**NOTE:** Do not perform more than one step at a time. Changing more than one variable at a time can complicate the troubleshooting process.

---

- 1 Halt all I/O to the storage system (see [Stopping I/O](#) on page 37).
- 2 Check the host activity LED.  
If there is activity, halt all applications that access the storage system.
- 3 Check the Cache Status LED to verify that the controller's cached data is flushed to the disk drives.
  - Solid – Cache is dirty (contains unwritten data) and is not writing to disk.
  - Blinking – Data is still being written to disk.
  - Off – Cache is clean (no unwritten data).

- 4 Reseat the expansion cable, and inspect it for damage.  
Is the expansion port status LED on?
  - Yes – Monitor the status to ensure there is no intermittent error present. If the fault occurs again, clean the connections to ensure that a dirty connector is not interfering with the data path.
  - No – Proceed to the next step.
- 5 Move the expansion cable to a port on the controller enclosure with a known good link status.  
This step isolates the problem to the expansion cable or to the controller module's expansion port.  
Is the expansion port status LED on?
  - Yes – You now know that the expansion cable is good. Return the cable to the original port. If the expansion port status LED remains off, you have isolated the fault to the controller module's expansion port. Replace the controller module.
  - No – Proceed to the next step.
- 6 Move the expansion cable back to the original port on the controller enclosure.
- 7 Move the expansion cable on the drive enclosure to a known good expansion port on the drive enclosure.  
Is the expansion port status LED on?
  - Yes – You have isolated the problem to the drive enclosure's port. Replace the expansion module.
  - No – Proceed to the next step.
- 8 Replace the cable with a known good cable, ensuring the cable is attached to the original ports used by the previous cable.  
Is the host link status LED on?
  - Yes – Replace the original cable. The fault has been isolated.
  - No – It is likely that the controller module must be replaced.

---

## Resolving voltage and temperature warnings

- 1 Check that all of the fans are working by making sure the Voltage/Fan Fault/Service Required LED on each PSU is off, or by using the Quantum StorNext Disk Storage Management Utility to check enclosure health status. In the Configuration View panel, right click the enclosure and click **View > Overview** to view the health status of the enclosure and its components.  
See [Options available for performing basic steps](#) on page 34 for a description of health status icons and alternatives for monitoring enclosure health.
- 2 Make sure that all modules are fully seated in their slots and that their latches are locked.
- 3 Make sure that no slots are left open for more than two minutes.  
If you need to replace a module, leave the old module in place until you have the replacement or use a blank module to fill the slot. Leaving a slot open negatively affects the airflow and can cause the enclosure to overheat.
- 4 Replace each PSU one at a time.
- 5 Replace the controller modules one at a time.

## Sensor locations

The storage system monitors conditions at different points within each enclosure to alert you to problems. Power, cooling fan, temperature, and voltage sensors are located at key points in the enclosure. In each controller module and expansion module, the EMP monitors the status of these sensors to perform SES functions.

The following sections describe each element and its sensors.

## PSU sensors

Each enclosure has two fully redundant power supplies with load-sharing capabilities. The PSU sensors described in [Table 19](#) monitor the voltage, current, temperature, and fans in each PSU. If the PSU sensors report a voltage that is under or over the threshold, check the input voltage.

**Table 19** PSU sensor descriptions

Description	Event/Fault ID LED condition
PSU 1	Voltage, current, temperature, or fan fault
PSU 2	Voltage, current, temperature, or fan fault

## Cooling fan sensors

Each PSU includes two fans. The normal range for fan speed is 4,000 to 6,000 r/min. When a fan speed drops below 4,000 r/min, the EMP considers it a failure and posts an alarm in the storage system's event log. [Table 20](#) lists the description, location, and alarm condition for each fan. If the fan speed remains under the 4,000 r/min threshold, the internal enclosure temperature may continue to rise. Replace the PSU reporting the fault.

**Table 20** Cooling fan sensor descriptions

Description	Location	Event/Fault ID LED condition
Fan 1	PSU 1	< 4,000 r/min
Fan 2	PSU 1	< 4,000 r/min
Fan 3	PSU 2	< 4,000 r/min
Fan 4	PSU 2	< 4,000 r/min

During a shutdown, the cooling fans do not shut off. This allows the enclosure to continue cooling.

## Temperature sensors

Extreme high and low temperatures can cause significant damage if they go unnoticed. Each controller module has six temperature sensors. Of these, if the CPU or FPGA temperature reaches a shutdown value, the controller module is automatically shut down. Each PSU has one temperature sensor.

When a temperature fault is reported, it must be remedied as quickly as possible to avoid system damage. This can be done by warming or cooling the installation location.

**Table 21** Controller module temperature sensor descriptions

Description	Normal operating range	Warning operating range	Critical operating range	Shutdown values
CPU temperature	3°C – 88°C	0°C – 3°C, 88°C – 90°C	> 90°C	0°C 100°C
FPGA temperature	3°C – 97°C	0°C – 3°C, 97°C – 100°C	None	0°C 105°C
Onboard temperature 1	0°C – 70°C	None	None	None
Onboard temperature 2	0°C – 70°C	None	None	None
Onboard temperature 3 (Capacitor temperature)	0°C – 70°C	None	None	None
CM temperature	5°C – 50°C	≤ 5°C, ≥ 50°C	≤ 0°C, ≥ 55°C	None

When a PSU sensor goes out of range, the Fault/ID LED illuminates amber and an event is posted to the event log.

**Table 22** PSU temperature sensor descriptions

Description	Normal operating range
PSU 1 temperature	–10°C – 80°C
PSU 2 temperature	–10°C – 80°C

## PSU voltage sensors

PSU voltage sensors ensure that an enclosure's PSU voltage is within normal ranges. There are three voltage sensors per PSU.

**Table 23** Voltage sensor descriptions

Sensor	Event/Fault LED condition
PSU 1 voltage, 12V	< 11.00V > 13.00V
PSU 1 voltage, 5V	< 4.00V > 6.00V
PSU 1 voltage, 3.3V	< 3.00V > 3.80V



# Appendix A

## LED descriptions

### StorNext QX-2400 front panel LEDs

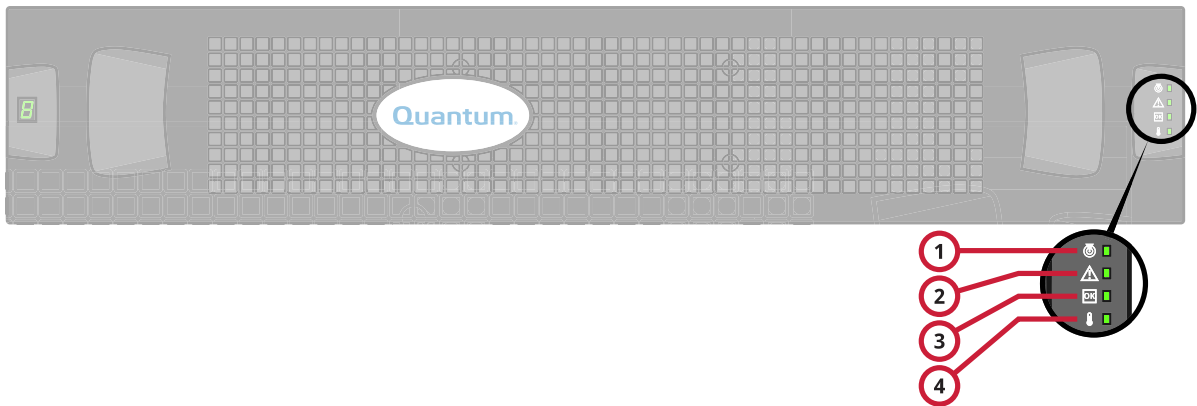
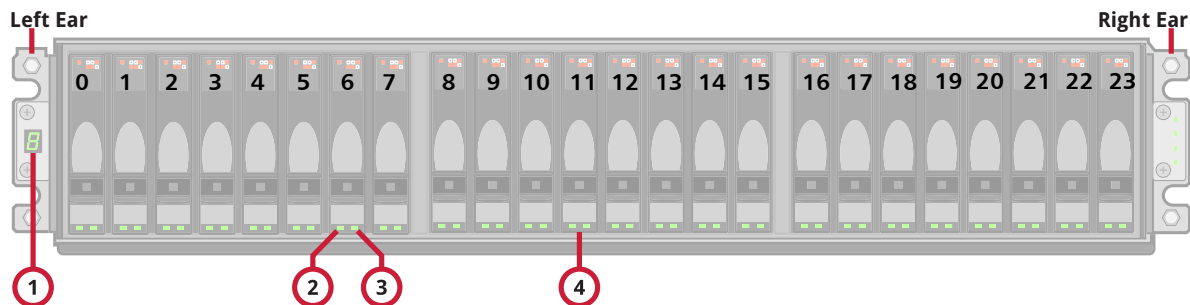

Figure 20 StorNext QX-2400 with bezel installed

Table 24 LEDs: 2U24 enclosure front panel (bezel installed)

LED	Description	Definition
1	Unit Locator	White blink — Enclosure is identified Off — Normal operation
2	Fault/Service Required	Amber — On Enclosure-level fault condition exists. The event has been acknowledged but the problem needs attention. Off — No fault condition exists.
3	FRU OK	Green — On The enclosure is powered on with at least one PSU operating normally. Off — Both power supplies are off; the system is powered off.
4	Temperature Fault	Green — On The enclosure temperature is normal. Amber — On The enclosure temperature is above threshold.



Note: Integers on disks indicate disk slot numbering sequence.

Figure 21 StorNext QX-2400 with bezel removed

Table 25 LEDs: 2U24 enclosure front panel (bezel removed)

LED	Description	Definition
1	Enclosure ID	Green — On Enables you to correlate the enclosure with logical views presented by management software. Sequential enclosure ID numbering of controller enclosures begins with the integer 0. The enclosure ID for an attached disk enclosure is nonzero.
2	Disk drive — Left LED	See <a href="#">Disk drive LEDs</a> on page 51.
3	Disk drive — Right LED	See <a href="#">Disk drive LEDs</a> on page 51.
4	Disk drive	24 disk drives

# StorNext QX-1200 front panel LEDs

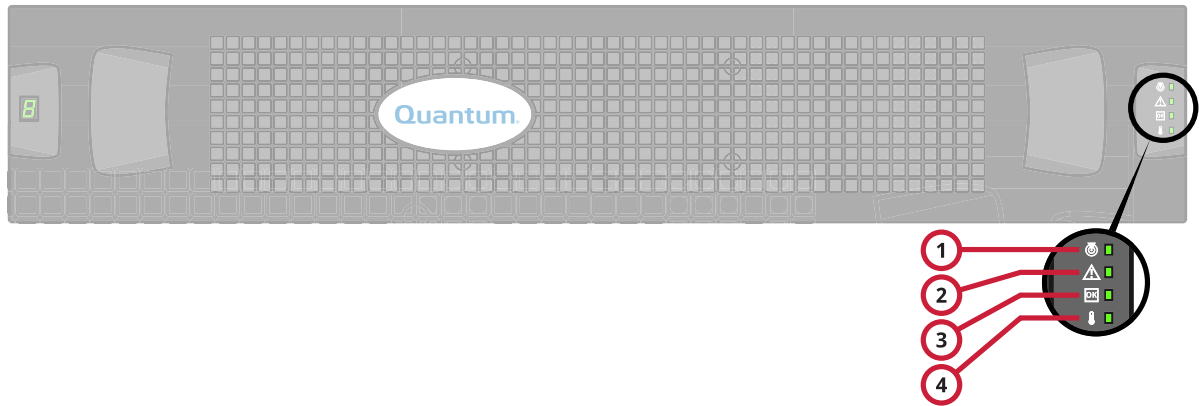
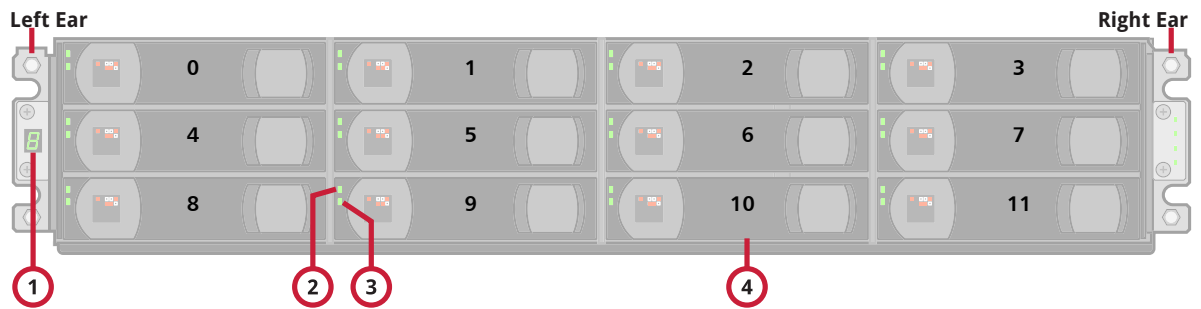

Figure 22 StorNext QX-1200 with bezel installed

Table 26 LEDs: 2U12 enclosure front panel (bezel installed)

LED	Description	Definition
1	Unit Locator	White blink — Enclosure is identified Off — Normal operation
2	Fault/Service Required	Amber — On Enclosure-level fault condition exists. The event has been acknowledged but the problem needs attention. Off — No fault condition exists.
3	FRU OK	Green — On The enclosure is powered on with at least one PSU operating normally. Off — Both power supplies are off; the system is powered off.
4	Temperature Fault	Green — On The enclosure temperature is normal. Amber — On The enclosure temperature is above threshold.



Note: Integers on disks indicate disk slot numbering sequence.

Figure 23 12-disk enclosure with bezel removed

Table 27 LEDs: 2U12 enclosure front panel (bezel removed)

LED	Description	Definition
1	Enclosure ID	Green — On Enables you to correlate the enclosure with logical views presented by management software. Sequential enclosure ID numbering of controller enclosures begins with the integer 0. The enclosure ID for an attached disk enclosure is nonzero.
2	Disk drive — Upper LED	See <a href="#">Disk drive LEDs</a> on page 51.
3	Disk drive — Lower LED	See <a href="#">Disk drive LEDs</a> on page 51.
4	Disk drive	12 disk drives



# Disk drive LEDs

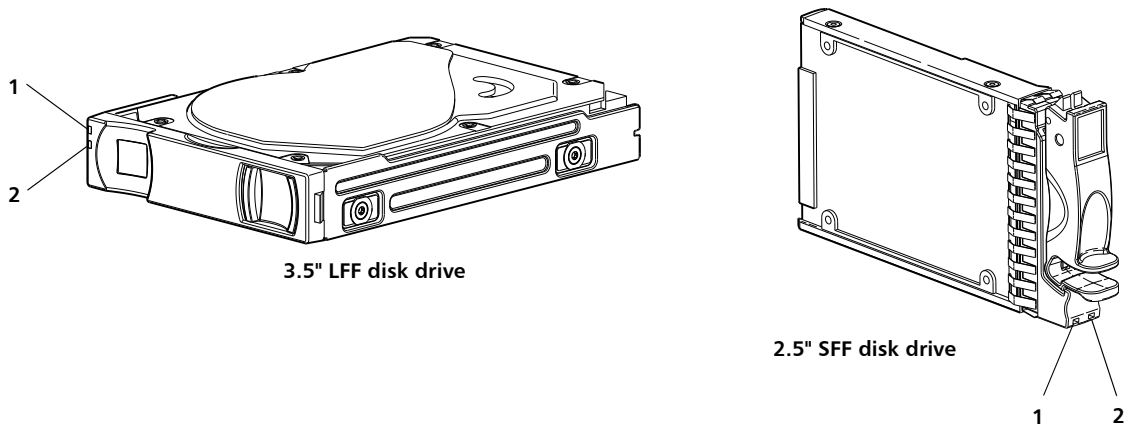

Figure 24 Disk drives

Table 28 LEDs: Disk drive

LED No./Description	Color	State	Definition
1— Power/Activity	Green	On	The disk drive module is operating normally.
		Blink	The disk drive module is initializing; active and processing I/O; performing a media scan; or the vdisk is initializing or reconstructing.
		Off	If not illuminated and Fault is not illuminated, the disk is not powered on.
2— Fault	Amber	On	The disk has failed; experienced a fault; is a leftover; or the vdisk that it is associated with is down or critical.
		Blink	Physically identifies the disk; or locates a leftover (also see Blue).
	Off	If not illuminated and Power/Activity is not illuminated, the disk is not powered on.	
	Blue	Blink	Leftover disk from vdisk is located (alternates blinking amber).

**NOTE:** If a user interface shows the disk LED is Fault (amber), while the enclosure shows it is green, the fault might be in the midplane or the disk's midplane connector.

**Table 29** LEDs: Disks in LFF and SFF enclosures

Disk drive module LED behavior		LFF — 12-disk		SFF — 24-disk	
Description	State	Color	Action	Color	Action
Disk drive OK, FTOL	Off	None	None	None	None
	On (operating normally)	Green	On	Green	On
	OK to remove	Green	Blink	Green	On
		Blue	On	Blue	On
	Identifying self — offline/online		Amber	Blink	Green <sup>1</sup>
Amber					Blink
Disk drive I/O	Initializing	Green	Blink	Green	Blink
	Active and processing I/O	Green	Blink	Green	Blink
	Performing a media scan	Green	Blink	Green	Blink
Disk drive leftover	Disk drive is a leftover	Amber	On	Amber	On
	Identifying a leftover	Amber <sup>2</sup>	Blink	Amber	Blink
		Blue <sup>1</sup>	On	Blue <sup>1</sup>	Blink
Disk drive failed	Fault or failure	Amber	On	Green <sup>1</sup>	On
				Amber	On
	Fault and remove disk drive	Amber	On	Green	On
				Blue	On
	Fault and identify disk drive	Amber	Blink	Green	On
				Amber	On
	Fault, identify, and remove disk drive	Amber	Blink	Green	On
				Blue	On
					Blue

<sup>1</sup>This color may or may not illuminate.

<sup>2</sup>Bitonal LED blinks amber/green.

 **NOTE:** If a user interface shows the disk LED is Fault (amber), while the enclosure shows it is green, the fault might be in the midplane or the disk's midplane connector.

**Table 30** LEDs: Vdisks in LFF and SFF enclosures

Vdisk LED behavior		LFF — 12-disk <sup>1</sup>		SFF — 24-disk	
Description	State	Color	Action	Color	Action
FTOL	On (operating normally)	Green	Blink	Green	On

**Table 30** LEDs: Vdisks in LFF and SFF enclosures (continued)

Vdisk LED behavior		LFF — 12-disk <sup>1</sup>		SFF — 24-disk	
Description	State	Color	Action	Color	Action
Vdisk activity	Vdisk is reconstructing	Green	Blink	Green	Blink
	Vdisk is initializing	Green	Blink	Green	Blink
Vdisk degraded	Vdisk is critical/down	See note 1 below		See note 1 below	

<sup>1</sup>Individual disks will display fault LEDs

## Controller enclosure: Rear panel layout

The diagram and table below display and identify important component items that comprise the rear panel layout of a StorNext QX Storage controller enclosure. The image shown is a representative example of controller enclosure models included in the product series.

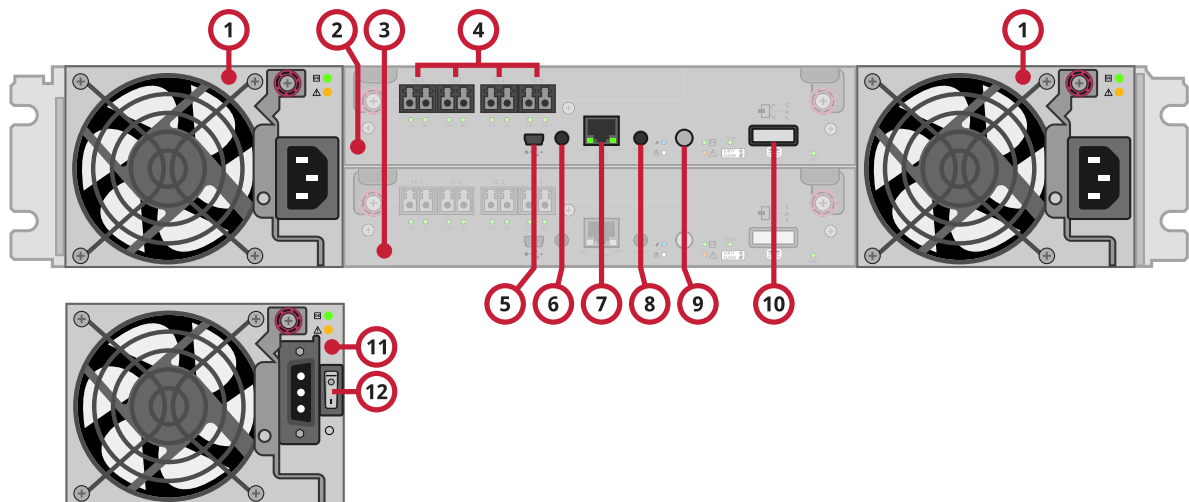

- |                            |   |
|----------------------------|---|
| 1 AC power supplies        | 7 Network port                                    |
| 2 Controller module A      | 8 Service port (used by service personnel only)   |
| 3 Controller module B      | 9 Disabled button (used by engineering/test only) |
| 4 FC ports: host interface | 10 Expansion port                                 |
| 5 CLI port (USB - Type B)  | 11 DC Power supply (2) — (DC model only)          |
| 6 Reserved for future use  | 12 DC Power switch                                |

**Figure 25** Example controller enclosure: Rear panel layout

A controller enclosure accommodates two PSU FRUs of the same type (either both AC or both DC) within the two PSU slots. The controller enclosure accommodates up to two controller module FRUs of the same type within the IOM slots.

[Figure 26](#) provides descriptions for the different controller modules and PSUs that can be installed into the rear panel of a StorNext QX Storage controller enclosure. Showing controller modules and PSUs separately from the enclosure enables improved clarity in identifying the component items called out in the diagrams and described in the tables.

LED descriptions are also provided for optional drive enclosures supported by the StorNext QX Storage controller enclosures.

## StorNext QX-2400/StorNext QX-1200 controller module: Rear panel LEDs

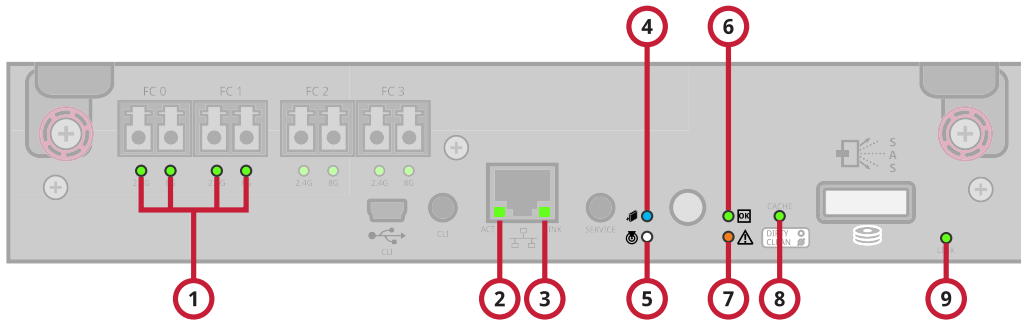

**Table 31**

LED No./Description	Color	State	Definition
1 — Host 2/4/8 Gbit FC Link Status/ Link Activity	Green	On	Port is connected and the link is up. 2,4 G LED illuminates — link speed is 2 or 4 Gbit/s 8 G LED illuminates — link speed is 8 Gbit/s
		Off	Both LEDs off — link speed is 1 Gbit/s <sup>1</sup>
		Blink	1Hz — no link detected
2 — Network Port Activity	Green	Off	Ethernet link has no I/O activity.
		Blink	Ethernet link has I/O activity.
3 — Network Port Link Status	Green	On	The Ethernet link is up.
		Off	Ethernet port is not connected or the link is down.
4 — OK to Remove	Blue	On	The controller module can be removed.
		Off	The controller module is not prepared for removal.
5 — Unit Locator	White	Off	Normal operation.
		Blink	Physically identifies the controller module.
6 — FRU OK	Green	On	Controller module is operating normally.
		Off	Controller module is not OK.
		Blink	System is booting.
7 — Fault/Service Required	Amber	On	A fault is detected or a service action is required.
		Blink	Hardware-controlled power-up, or a cache flush or restore error.

**Table 31**

LED No./Description	Color	State	Definition
8 — Cache Status	Green	On	Cache is dirty (contains unwritten data) and operation is normal.
		Off	Cache is clean (contains no unwritten data).
		Blink	CompactFlash flush or cache self-refresh is in progress, indicating cache activity. (See <a href="#">Cache Status LED details</a> on page 55)
9 — Expansion Port Status	Green	On	Port is connected and the link is up.
		Off	Port is empty or link is down.

<sup>1</sup>The 8 Gbit SFP modules do not support 1 Gbit link speeds.

**Figure 26** StorNext QX-2400/StorNext QX-1200 controller module

 **NOTE:** Once a Link Status LED is lit, it remains so, even if the controller is shut down via the Quantum StorNext Disk Storage Management Utility or CLI.

When a controller is shut down or otherwise rendered inactive, its Link Status LED remains illuminated, falsely indicating that the controller can communicate with the host. Though a link exists between the host and the chip on the controller, the controller is not communicating with the chip. To reset the LED, the controller must be power-cycled (see [Powering on/powering off](#) on page 14).

## Cache Status LED details

If the LED is blinking evenly, a cache flush is in progress. When a controller module loses power and write cache is dirty (contains data that has not been written to disk), the supercapacitor pack provides backup power to flush (copy) data from write cache to CompactFlash memory. When cache flush is complete, the cache transitions into self-refresh mode.

If the LED is blinking momentarily slowly, the cache is in a self-refresh mode. In self-refresh mode, if primary power is restored before the backup power is depleted (3–30 minutes, depending on various factors), the system boots, finds data preserved in cache, and writes it to disk. This means the system can be operational within 30 seconds, and before the typical host I/O time-out of 60 seconds, at which point system failure would cause host-application failure. If primary power is restored after the backup power is depleted, the system boots and restores data to cache from CompactFlash, which can take about 90 seconds.

The cache flush and self-refresh mechanism is an important data protection feature; essentially four copies of user data are preserved: one in controller cache and one in CompactFlash of each controller.

The LED becomes solid green during the boot-up process. This indicates the cache is logging all POSTs, which will be flushed to the CompactFlash the next time the controller shuts down.

 **CAUTION:** If the Cache Status LED is solid green, the controller should be shut-down from the user interface so unwritten data can be flushed to the CompactFlash.

## PSU LEDs

Power redundancy is achieved through two independent load-sharing power supplies. In the event of a PSU failure, or the failure of the power source, the storage system can operate continuously on a single PSU. Greater redundancy can be achieved by connecting the power supplies to separate circuits. DC power supplies are equipped with a power switch. AC power supplies may or may not have a power switch (the newer model in [Figure 27](#) has no power switch). Whether a PSU has a power switch is significant to powering on/off.

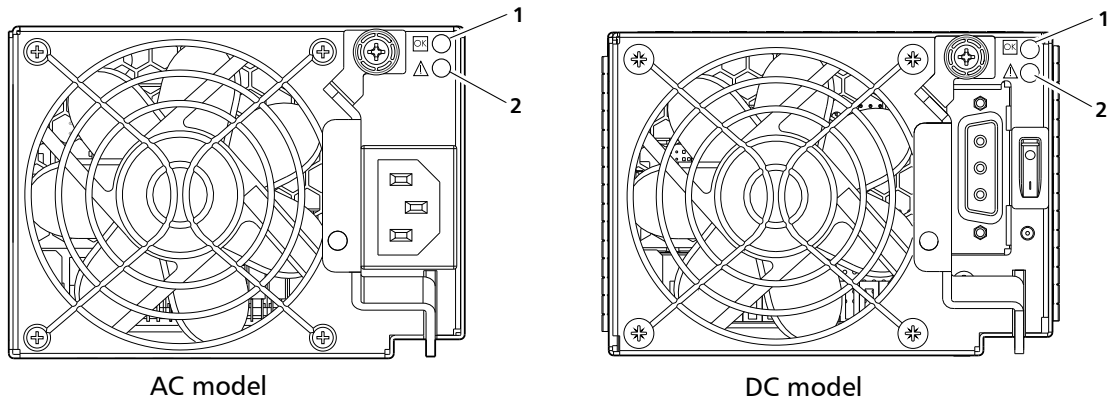

Table 32

LED No./Description	Color	State	Definition
1 — Input Source Power Good	Green	On	Power is on and input voltage is normal.
		Off	Power is off, or input voltage is below the minimum threshold.
2 — Voltage/Fan Fault/Service Required	Amber	On	Output voltage is out of range, or a fan is operating below the minimum required r/min.
		Off	Output voltage is normal.

Figure 27 PSUs

 **NOTE:** See [Powering on/powering off](#) on page 14 for information on power-cycling enclosures.

## QX 24-Drive Expansion Module/QX 12-Drive Expansion Module drive enclosure rear panel LEDs

The rear panel layouts of the QX 24-Drive Expansion Module and QX 12-Drive Expansion Module drive enclosures are nearly identical. Both models support 6-Gbit/s. Accordingly, the expansion modules feature a “6 Gb/s” label above each SAS (ingress/egress) expansion port.

Newer models of these drive enclosures feature AC power supplies without power switches, as per the system shown below. See [Powering on/powering off](#) on page 14 for more information.

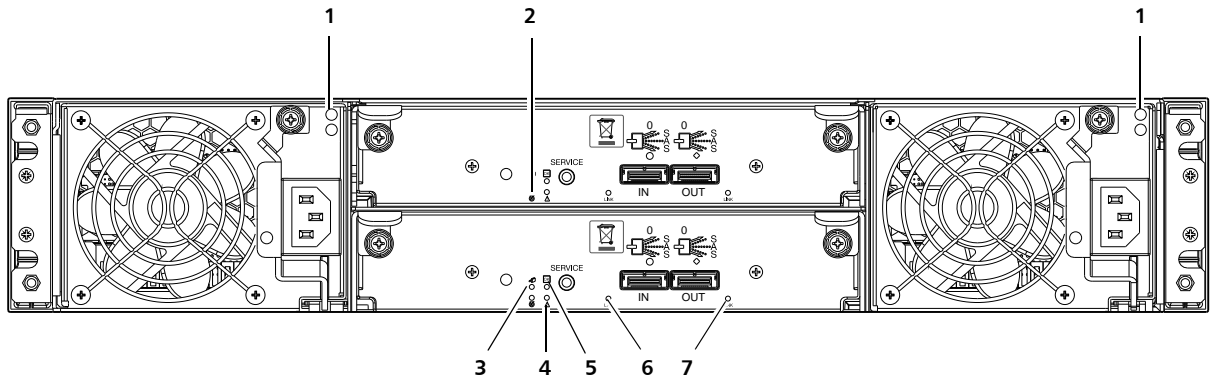

Note: Callouts do not tag multiple instances of an identified LED.

Table 33

LED No./Description	Color	State	Definition
1 — PSU	—	—	See <a href="#">PSU LEDs</a> on page 56.
2 — Unit Locator	White	Off Blink	Normal operation. Physically identifies the expansion module.
3 — OK to Remove	Blue	Off	Not implemented.
4 — Fault/Service Required	Amber	On Blink	A fault is detected or a service action is required. Hardware-controlled power-up.
5 — FRU OK	Green	On Off Blink	Expansion module is operating normally. Expansion module is not OK. System is booting.
6 — SAS In Port Status	Green	On Off	Port is connected and the link is up. Port is empty or link is down.
7 — SAS Out Port Status	Green	On Off	Port is connected and the link is up. Port is empty or link is down.

Figure 28 QX 24-Drive Expansion Module/QX 12-Drive Expansion Module drive enclosure







# Environmental requirements and specifications

## Safety requirements

Install the system in accordance with the local safety codes and regulations at the facility site. Follow all cautions and instructions marked on the equipment.

 **IMPORTANT:** Also see the hard copy Quantum StorNext QX Storage Product Regulatory Compliance and Safety document (included with your product).

## Site requirements and guidelines

The following sections provide requirements and guidelines that you must address when preparing your site for the installation.

When selecting an installation site for the system, choose a location not subject to excessive heat, direct sunlight, dust, or chemical exposure. These conditions greatly reduce the system’s longevity and might void your warranty.

### Site wiring and AC power requirements

The following are required for all installations using AC power supplies:

**Table 34** Power requirements - AC Input

Measurement	Rating
Input power requirements	100 to 240VAC, 50/60Hz
Maximum input power	436W maximum continuous
Heat dissipation	1,488 BTUs/hour

- All AC mains and supply conductors to power distribution boxes for the rack-mounted system must be enclosed in a metal conduit or raceway when specified by local, national, or other applicable government codes and regulations.
- Ensure that the voltage and frequency of your power source match the voltage and frequency inscribed on the equipment’s electrical rating label.

- To ensure redundancy, provide two separate power sources for the enclosures. These power sources must be independent of each other, and each must be controlled by a separate circuit breaker at the power distribution point.
- The system requires voltages within minimum fluctuation. The customer-supplied facilities' voltage must maintain a voltage with not more than  $\pm 5$  percent fluctuation. The customer facilities must also provide suitable surge protection.
- Site wiring must include an earth ground connection to the AC power source. The supply conductors and power distribution boxes (or equivalent metal enclosure) must be grounded at both ends.
- Power circuits and associated circuit breakers must provide sufficient power and overload protection. To prevent possible damage to the AC power distribution boxes and other components in the rack, use an external, independent power source that is isolated from large switching loads (such as air conditioning motors, elevator motors, and factory loads).

## Site wiring and DC power requirements

The following are required for all installations using DC power supplies:

**Table 35** Power requirements - DC Input

Measurement	Rating
Input power requirements	-40 to -72VDC, -48/-60V nominal
Maximum input power	436W maximum continuous
Heat dissipation	1,488 BTUs/hour

The StorNext QX Storage system is suitable for installation as part of the Common Bonding Network (CBN). The system's Battery Return (BR) Input Terminals are considered to be an Isolated DC Return (DC-I).

The following criteria are required for all installations:

- All DC mains and supply conductors to power distribution boxes for the rack-mounted system must comply with local, national, or other applicable government codes and regulations.
- Ensure that the voltage of your power source matches the voltage inscribed on the equipment's electrical label.
- To ensure redundancy, provide two separate power sources for the enclosures. These power sources must be independent of each other, and each must be controlled by a separate circuit breaker at the power distribution point.
- The system requires voltages within minimum fluctuation. The customer-supplied facilities' voltage must maintain a voltage within the range specified on the equipment's electrical rating label. The customer facilities must also provide suitable surge protection.
- Site wiring must include an earth ground connection to the DC power source. Grounding must comply with local, national, or other applicable government codes and regulations.
- Power circuits and associated circuit breakers must provide sufficient power and overload protection.

## Weight and placement guidelines

Refer to [Physical requirements](#) on page 62 for detailed size and weight specifications.

- The weight of an enclosure depends on the number and type of modules installed.
- Ideally, use two people to lift an enclosure. However, one person can safely lift an enclosure if its weight is reduced by removing the PSUs and disk drive modules.
- Do not place enclosures in a vertical position. Always install and operate the enclosures in a horizontal orientation.
- When installing enclosures in a rack, make sure that any surfaces over which you might move the rack can support the weight. To prevent accidents when moving equipment, especially on sloped loading docks and up ramps to raised floors, ensure you have a sufficient number of helpers. Remove obstacles such as cables and other objects from the floor.
- To prevent the rack from tipping, and to minimize personnel injury in the event of a seismic occurrence, securely anchor the rack to a wall or other rigid structure that is attached to both the floor and to the ceiling of the room.

## Electrical guidelines

- These enclosures work with single-phase power systems having an earth ground connection. To reduce the risk of electric shock, do not plug an enclosure into any other type of power system. Contact your facilities manager or a qualified electrician if you are not sure what type of power is supplied to your building.
- Enclosures are shipped with a grounding-type (three-wire) power cord. To reduce the risk of electric shock, always plug the cord into a grounded power outlet.
- Do not use household extension cords with the enclosures. Not all power cords have the same current ratings. Household extension cords do not have overload protection and are not meant for use with computer systems.

## Ventilation requirements

Refer to [Environmental requirements](#) on page 64 for detailed environmental requirements.

- Do not block or cover ventilation openings at the front and rear of an enclosure. Never place an enclosure near a radiator or heating vent. Failure to follow these guidelines can cause overheating and affect the reliability and warranty of your enclosure.
- Leave a minimum of 15.2 cm (6 inches) at the front and rear of each enclosure to ensure adequate airflow for cooling. No cooling clearance is required on the sides, top, or bottom of enclosures.
- Leave enough space in the front and rear of an enclosure to allow access to enclosure components for servicing. Removing a component requires a clearance of at least 38.1 cm (15 inches) in front of and behind the enclosure.

## Cabling requirements

- Keep power and interface cables clear of foot traffic. Route cables in locations that protect the cables from damage.
- Route interface cables away from motors and other sources of magnetic or radio frequency interference.
- Stay within the cable length limitations.
- StorNext QX Storage controller and drive enclosures are suitable for connection to intra-building or non-exposed wiring or cabling only.

- StorNext QX Storage controller and drive enclosures are suitable for installation in Network Telecommunication Facilities and locations where the NEC applies. StorNext QX Storage enclosures are not suitable for Outside Plant (OSP) installations.

---

## Management host requirements

A local management host with at least one mini-USB connection is recommended for the initial installation and configuration of a controller enclosure. After you configure one or both of the controller modules with an IP address, you then use a remote management host on an Ethernet network to manage and monitor.

---

## Physical requirements

The floor space at the installation site must be strong enough to support the combined weight of the rack, controller enclosures, drive enclosures, and any additional equipment. The site also requires sufficient space for installation, operation, and servicing of the enclosures, together with sufficient ventilation to allow a free flow of air to all enclosures.

The chassis of a StorNext QX Storage controller or drive enclosure is comprised of sheet steel that is bonded together using rivets, welding, and other forced contact methods. The metal surfaces are free from non-conductive coatings and paint.

[Table 36](#) and [Table 37](#) on page 63 show enclosure dimensions and weights. Enclosure designators are described below. Enclosure weights assume the following configuration characteristics:

- 2U12 enclosure (LFF):
  - “2U12” denotes the 3.5" StorNext QX-1200 enclosure (with controller or expansion modules)
  - The 2U12 chassis is equipped with a disk in each disk drive slot
- 2U24 enclosure (SFF):
  - “2U24” denotes the 2.5" StorNext QX-2400 enclosure (with controller or expansion modules)
  - The 2U24 chassis is equipped with a disk in each disk drive slot
- Two controller modules or two expansion modules per enclosure
- Two PSUs per enclosure

**Table 36** Rackmount enclosure dimensions

Specifications	Rackmount
2U Height (y-axis):	8.9 cm (3.5 inches)
Width (x-axis):	
<ul style="list-style-type: none"> <li>Chassis-only</li> <li>Chassis with ear caps or enclosure bezel</li> </ul>	<ul style="list-style-type: none"> <li>44.7 cm (17.6 inches)</li> <li>47.9 cm (18.9 inches)</li> </ul>
SFF (2U24):	
<ul style="list-style-type: none"> <li>Rear of chassis ear to controller latch</li> <li>Front of chassis ear to rear of cable bend</li> </ul>	<ul style="list-style-type: none"> <li>51.8 cm (20.4 inches)</li> <li>57.9 cm (22.8 inches)</li> </ul>
LFF (2U12):	
<ul style="list-style-type: none"> <li>Rear of chassis ear to controller latch</li> <li>Front of chassis ear to rear of cable bend</li> </ul>	<ul style="list-style-type: none"> <li>54.9 cm (21.6 inches)</li> <li>59.9 cm (23.6 inches)</li> </ul>

**Table 37** Rackmount controller enclosure weights

Specifications	Rackmount
SFF (2U24):	8.6 kg (19.0 lb) [chassis]
<ul style="list-style-type: none"> <li>Chassis with FRUs (no disks)<sup>1-3</sup></li> <li>Chassis with FRUs (including disks)<sup>1-4</sup></li> </ul>	<ul style="list-style-type: none"> <li>17.4 kg (38.4 lb)</li> <li>23.4 kg (51.6 lb)</li> </ul>
LFF (2U12)	8.5 kg (18.8 lb) [chassis]
<ul style="list-style-type: none"> <li>Chassis with FRUs (no disks)<sup>1-3</sup></li> <li>Chassis with FRUs (including disks)<sup>1-4</sup></li> </ul>	<ul style="list-style-type: none"> <li>17.3 kg (38.2 lb)</li> <li>26.9 kg (59.2 lb)</li> </ul>

<sup>1</sup>Weights shown are nominal, and subject to variances.

<sup>2</sup>Rail kits add between 2.8 kg (6.2 lb) and 3.4 kg (7.4 lb) to the aggregate enclosure weight.

<sup>3</sup>Weights may vary due to different power supplies, IOMs, and differing calibrations between scales.

<sup>4</sup>Weights may vary due to actual number and type of disk drives (SAS SSD, enterprise SAS, or midline SAS) and air management modules installed.

**Table 38** provides information about optional drive enclosures that are compatible with StorNext QX Storage controller enclosures.

**Table 38** Rackmount compatible drive enclosure weights (ordered separately)

Specifications	Rackmount
StorNext QX Storage (SFF 2.5" 24-disk)	8.6 kg (19.0 lb) [chassis]
<ul style="list-style-type: none"> <li>Chassis with FRUs (no disks)<sup>1-3</sup></li> <li>Chassis with FRUs (including disks)<sup>1-4</sup></li> </ul>	<ul style="list-style-type: none"> <li>16.2 kg (35.8 lb)</li> <li>22.2 kg (49.0 lb)</li> </ul>
StorNext QX Storage (LFF 3.5")	8.5 kg (18.8 lb) [chassis]
<ul style="list-style-type: none"> <li>Chassis with FRUs (no disks)<sup>1-3</sup></li> <li>Chassis with FRUs (including disks)<sup>1-4</sup></li> </ul>	<ul style="list-style-type: none"> <li>16.1 kg (35.6 lb)</li> <li>25.6 kg (56.6 lb)</li> </ul>

<sup>1</sup>Weights shown are nominal, and subject to variances.

<sup>2</sup>Rail kits add between 2.8 kg (6.2 lb) and 3.4 kg (7.4 lb) to the aggregate enclosure weight.

<sup>3</sup>Weights may vary due to different power supplies and differing calibrations between scales.

<sup>4</sup>Weights may vary due to actual number and type of disk drives (SAS SSD, enterprise SAS, or midline SAS) and air management modules installed.

---

## Environmental requirements

**Table 39** Operating environmental specifications

Specification	Range
Altitude	To 3,000 meters (10,000 feet )
Temperature*	5°C to 40°C (41°F to 104°F)
Humidity	10% to 90% RH up to 40°C (104°F) non-condensing
Shock	5.0 g, 11 ms, ½ sine pulses, X, Y, Z
Vibration	(Shaped-spectrum) 5 Hz to 500 Hz, 0.114 G <sub>rms</sub> total X, Y, Z

\*Temperature is de-rated by 2°C (3.6°F) for every 1 km (3,281) feet above sea level.

**Table 40** Non-operating environmental specifications

Specification	Range
Altitude	To 12,000 meters (39,370 feet)
Temperature	-40°C to 70°C (-40°F to 158°F)
Humidity	Up to 93% RH @ 104°F (40°C) non-condensing
Shock	15.0 g, 11 ms, ½ sine pulses, X, Y, Z
Vibration	(Shaped-spectrum) 2.8 Hz to 365.4 Hz, 0.852 G <sub>rms</sub> total (horizontal) 2.8 Hz to 365.4 Hz, 1.222 G <sub>rms</sub> total (vertical)

---

 **NOTE:** For additional information about Telco and ruggedized products, see Quantum’s web site: <http://www.quantum.com>.

---

---

## Electrical requirements

### Site wiring and power requirements

Each enclosure has two PSUs for redundancy. If full redundancy is required, use a separate power source for each module. The AC PSU in each PSU is auto-ranging and is automatically configured to an input voltage range from 88 – 264 VAC with an input frequency of 47 – 63 Hz. The PSUs meet standard voltage requirements for both U.S. and international operation. The PSUs use standard industrial wiring with line-to-neutral or line-to-line power connections.

## Power cable requirements

Each enclosure ships with two power cables designed for use with the enclosure PSU type (AC or DC). AC power cords ship with enclosures equipped with AC PSUs. DC power cables ship with enclosures equipped with DC PSUs. Each power cable connects one of the PSUs to an independent, external power source. To ensure power redundancy, connect the two power cables to two separate circuits; for example, to one commercial circuit and one UPS.







## Appendix C

# Electrostatic discharge

---

To prevent ESD from damaging the system, be aware of the precautions to consider when setting up the system or handling parts. A discharge of static electricity from a finger or other conductor may damage system boards or other static-sensitive devices. This type of damage may reduce the life expectancy of the device.

---

△ **CAUTION:** Parts can be damaged by ESD. Follow these precautions:

- Avoid hand contact by transporting and storing products in static-safe containers.
  - Keep electrostatic-sensitive parts in their containers until they arrive at static-protected workstations.
  - Place parts in a static-protected area before removing them from their containers.
  - Avoid touching pins, leads, or circuitry.
  - Always be properly grounded when touching a static-sensitive component or assembly.
  - Remove clutter (plastic, vinyl, foam) from the static-protected workstation.
- 

## Grounding methods to prevent ESD

Several methods are used for grounding. Adhere to the following precautions when handling or installing electrostatic-sensitive parts.

---

△ **CAUTION:** Parts can be damaged by ESD. Use proper anti-static protection:

- Keep the replacement FRU in the ESD bag until needed; and when removing a FRU from the enclosure, immediately place it in the ESD bag and anti-static packaging.
- Wear an ESD wrist strap connected by a ground cord to a grounded workstation or unpainted surface of the computer chassis. Wrist straps are flexible straps with a minimum of 1 megohm ( $\pm 10$  percent) resistance in the ground cords. To provide proper ground, wear the strap snug against the skin.
- If an ESD wrist strap is unavailable, touch an unpainted surface of the chassis before handling the component.
- Use heel straps, toe straps, or boot straps at standing workstations. Wear the straps on both feet when standing on conductive floors or dissipating floor mats.
- Use conductive field service tools.

- Use a portable field service kit with a folding static-dissipating work mat.
- 

If you do not have any of the suggested equipment for proper grounding, have an authorized reseller install the part. For more information on static electricity or assistance with product installation, contact an authorized reseller.



# USB device connection

## Rear panel USB ports

Quantum StorNext QX Storage controllers contain a USB device management interface. This interface pertains to the MC and is accessed via its port on the controller module face plate. This appendix describes the port labeled CLI (USB Type B), which enables direct connection between a management computer and the controller, using the CLI and appropriate cable (see [Figure 29](#) for USB port locations).

### USB the CLI port

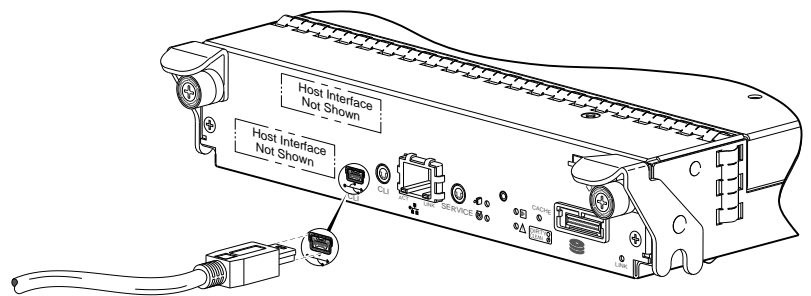

Connect USB cable to CLI port on controller face plate

Figure 29 USB device connection: CLI port

Quantum StorNext QX Storage controllers feature a USB CLI port used to cable directly to the controller and initially set IP addresses, or perform other configuration tasks. The USB CLI port employs a mini-USB Type B form factor, and requires a new cable and additional support, so that a server or other computer running a Linux or Windows operating system can recognize the controller enclosure as a connected device. Without this support, the computer might not recognize that a new device is connected, or might not be able to communicate with it.

For Linux computers, no new driver files are needed, but a Linux configuration file must be created or modified (see [Linux](#) on page 71). For Windows computers a special device driver file, `gserial.inf`, must be downloaded and installed on the computer that will be cabled directly to the controller's CLI port (see [Microsoft Windows](#) on page 71).

## Emulated serial port

Once attached to the controller module, the management computer should detect a new USB device. Using the Emulated Serial Port interface, the StorNext QX Storage controller presents a single serial port using a *customer vendor ID* and *product ID*. Effective presentation of the emulated serial port assumes the management computer previously had terminal emulator installed (see [Supported host applications](#)). Serial port configuration is unnecessary.

---

 **IMPORTANT:** Certain operating systems require a device driver or special mode of operation to enable proper functioning of the USB CLI port (see [Device driver/special operation mode](#)).

---

## Supported host applications

StorNext QX Storage controllers support the following applications to facilitate connection.

**Table 41** Supported terminal emulator applications

Application	Operating system
HyperTerminal and TeraTerm	Microsoft Windows (all versions)
Minicom	Linux (all versions)
	Solaris
	HP-UX

## CLI

The MC provides direct access to the CLI.

---

 **NOTE:** Directly cabling to the CLI port is an out-of-band connection, because it communicates outside of the data paths used to transfer information from a computer or network to the controller enclosure.

---

---

## Device driver/special operation mode

Certain operating systems require a device driver or special mode of operation. Product and vendor identification information required for such setup is provided in [Table 42](#).

**Table 42** USB vendor and product identification codes

USB Identification code type	Code
Quantum vendor ID code	0x210C
Quantum StorNext QX Storage product ID code	0xa4a7

## Microsoft Windows

Microsoft Windows operating systems provide a USB serial port driver. However, the USB driver requires details for connecting to Quantum StorNext QX Storage controller enclosures. Quantum provides a device driver for use in the Windows environment. Please contact Quantum for instructions about how to download this driver.

## Linux

Although Linux operating systems do not require installation of a device driver, certain parameters must be provided during driver loading to enable recognition of the Quantum StorNext QX Storage controller enclosures.

### Setting parameters for the device driver

- 1 Enter the following command:

```
sudo modprobe usbserial vendor=0x210c product=0xa4a7 use_acm=1
```

- 2 Press **Enter** to execute the command.

The Linux device driver is loaded with the parameters required to recognize the controllers.



**NOTE:** Optionally, this information can be incorporated into the `/etc./modules.conf` file.

---





# Glossary

---

<b>array</b>	See storage system
<b>chassis</b>	The sheetmetal housing of an enclosure.
<b>controller A (or B)</b>	A short way of referring to controller module A (or B).
<b>controller enclosure</b>	An enclosure that contains one or two controller modules.
<b>controller module</b>	A FRU that contains the following subsystems and devices: an SC processor; an MC processor; management interfaces; cache protected by a supercapacitor pack and nonvolatile memory (CompactFlash); host, expansion, network, and service ports; and midplane connectivity. In a controller enclosure, the upper controller module is designated <i>A</i> and the lower one is designated <i>B</i> .
<b>DAS</b>	Direct Attach Storage. A dedicated storage device that connects directly to a host without the use of a switch.
<b>DHCP</b>	Dynamic Host Configuration Protocol. A network configuration protocol for hosts on IP networks.
<b>Direct Attach Storage</b>	See DAS.
<b>drive enclosure</b>	An enclosure that contains one or two expansion modules. Drive enclosures can be connected to a controller enclosure to provide additional storage capacity.
<b>dual-port disk</b>	A disk that is connected to both controllers so its data path is fault-tolerant.
<b>Dynamic Host Configuration Protocol</b>	See DHCP.
<b>electromagnetic interface</b>	See EMI.
<b>EMI</b>	Electromagnetic interface.
<b>EMP</b>	Enclosure management processor. An EC subsystem that provides SES data such as temperature, PSU and fan status, and the presence or absence of disks.
<b>enclosure</b>	A physical storage device that contains disk drives and other FRUs.

<b>enclosure management processor</b>	See EMP.
<b>Expander Controller</b>	See EC.
<b>expansion enclosure</b>	See drive enclosure.
<b>expansion module</b>	A FRU that contains the following subsystems and devices: host, expansion, and service ports; and midplane connectivity. In a drive enclosure, the upper expansion module is designated <i>A</i> and the lower one is designated <i>B</i> .
<b>FC-AL</b>	Fibre Channel Arbitrated Loop. The FC topology in which devices are connected in a one-way loop.
<b>Fibre Channel Arbitrated Loop</b>	See FC-AL.
<b>field-programmable gate array</b>	See FPGA.
<b>field-replaceable unit</b>	See FRU.
<b>FPGA</b>	Field-programmable gate array. An integrated circuit designed to be configured after manufacturing.
<b>FRU</b>	Field-replaceable unit. A part that can be removed and replaced by the user or support technician without having to send the product to a repair facility.
<b>HBA</b>	Host bus adapter. A device that facilitates I/O processing and physical connectivity between a host and the storage system.
<b>host</b>	An external port that the storage system is connected to. The external port may be a port in an I/O adapter in a server, or a port in a network switch. Product interfaces use the terms host and initiator interchangeably.
<b>host port</b>	A port on a controller module that interfaces to a host computer, either directly or through a network switch.
<b>host bus adapter</b>	See HBA.
<b>I/O module</b>	See IOM.
<b>intrinsic methods</b>	Methods inherited from CIM and present in all classes such as <code>getclass</code> , <code>createinstance</code> , <code>enumerateinstances</code> , and <code>associatorNames</code> in SMI-S.
<b>IOM</b>	I/O module. An IOM can be either a controller module or an expansion module.
<b>JBOD</b>	"Just a bunch of disks." See also drive enclosure.
<b>large form factor</b>	See LFF.
<b>leftover</b>	The state of a disk that the system has excluded from a vdisk because the timestamp in the disks's metadata is older than the timestamp of other disks in the vdisk, or because the disk was not detected during a rescan. A leftover disk cannot be used in another vdisk until the disk's metadata is cleared; for information and cautions about doing so, see documentation topics about clearing disk metadata.
<b>LFF</b>	Large form factor. A type of disk drive.



<b>Logical Unit Number</b>	See LUN.
<b>loop</b>	FC-AL topology.
<b>LUN</b>	Logical Unit Number. A number that identifies a mapped Volume to a host.
<b>Management Controller</b>	See MC.
<b>map/mapping</b>	Settings that specify whether a volume is presented as a storage device to a host, and how the host can access the volume. Mapping settings include an access type (read-write, read-only, or no access), controller host ports through which initiators may access the volume, and a LUN that identifies the volume to the host.
<b>MC</b>	Management Controller. A processor located in a controller module that is responsible for human-computer interfaces and computer-computer interfaces, including the WBI, CLI, and FTP interfaces, and interacts with the SC. See also EC and SC.
<b>metadata</b>	Data in the first sectors of a disk drive that stores all disk-, vdisk-, and volume-specific information including vdisk membership or spare ID, vdisk ownership, volumes in the vdisk, host mapping of volumes, and results of the last media scrub.
<b>MMF</b>	Multimode fiber.
<b>mount</b>	To enable access to a volume from a host OS.
<b>multimode fiber</b>	See MMF.
<b>network port</b>	An Ethernet port on a controller module through which its MC is connected to the network.
<b>point-to-point</b>	The FC topology where two ports are directly connected.
<b>POST</b>	Power-On Self Test. Tests that run immediately after a device is powered on.
<b>Power-on Self Test</b>	See POST.
<b>Power Supply Unit</b>	See PSU.
<b>PSU</b>	Power Supply Unit. The power supply FRU.
<b>recovery</b>	In an active-active configuration, recovery is the act of returning ownership of controller resources to a controller (which was offline) from its partner controller. The resources include volumes, cache data, host ID information, and LUNs and WWNs.
<b>SC</b>	Storage Controller. A processor located in a controller module that is responsible for RAID controller functions. The SC is also referred to as the RAID controller. See also EC and MC.
<b>SCSI Enclosure Services</b>	See SES.
<b>secure shell</b>	See SSH.
<b>SES</b>	SCSI Enclosure Services. The protocol that allows the initiator to communicate with the enclosure using SCSI commands.
<b>SFF</b>	Small form factor. A type of disk drive.
<b>shelf</b>	See enclosure.

<b>small form factor</b>	See SFF.
<b>SMI-S</b>	Storage Management Initiative - Specification. The SNIA standard that enables interoperable management of storage networks and storage devices. The interpretation of CIM for storage. It provides a consistent definition and structure of data, using object-oriented techniques.
<b>SNIA</b>	Storage Networking Industry Association. An association regarding storage networking technology and applications.
<b>SSH</b>	Secure Shell. A network protocol for secure data communication.
<b>Storage Controller</b>	See SC.
<b>Storage Management Initiative - Specification</b>	See SMI-S.
<b>Storage Networking Industry Association</b>	See SNIA.
<b>storage system</b>	A controller enclosure with at least one connected drive enclosure. Product documentation and interfaces use the terms storage system and system interchangeably.
<b>ULP</b>	Unified LUN Presentation. A RAID controller feature that enables a host to access mapped volumes through either controller's host ports. ULP incorporates ALUA extensions.
<b>Unified LUN Presentation</b>	See ULP.
<b>Uninterruptible Power Source</b>	See UPS.
<b>UPS</b>	Uninterruptible Power Source.
<b>vdisk</b>	A virtual disk comprised of the capacity of one or more physical disks. The number of disks that a vdisk can contain is determined by its RAID level.
<b>virtual disk</b>	See vdisk.
<b>volume</b>	A portion of the capacity of a vdisk that can be presented as a storage device to a host.
<b>web-based interface/web-browser interface</b>	See WBI.
<b>WBI</b>	Web-based interface/web-browser interface. The primary interface for managing the system. A user can enable the use of HTTP, HTTPS for increased security, or both.

## A

audience [xi](#)

## C

cables

- FCC compliance statement [23](#)
- shielded [23](#)

cabling

- cable routing requirements [61](#)
- connecting controller and drive enclosures [9](#)
- considerations [19](#)
- direct attach configurations [20](#)
- switch attach configurations [22](#)

cache

- read-ahead [5](#)
- write-back or write-through [5](#)

clearance requirements

- service [61](#)
- ventilation [61](#)

components

- 12-drive enclosure front panel [2](#)
- 24-drive enclosure front panel [1](#)
- CLI port
  - USB [3](#)
- controller enclosure rear panel [3](#)
- controller module A [3](#)
- controller module B [3](#)
- expansion port [3](#)
- host interface port
  - FC [3](#)
- network port [3](#)
- PSU
  - AC [3](#)
  - DC [3](#)
  - DC power switch [3](#)
- PSU, AC [53](#)
- PSU, DC [53](#)
- StorNext QX 1200/2400 rear panel
  - CLI port (USB) [4](#)
  - E/T button (disabled) [4](#)

- expansion port [4](#)
- FC ports (host interface) [4](#)
- network port [4](#)
- service port [4](#)
- connecting
  - controller enclosures to hosts [19](#)
  - to remote management hosts [23](#)
- connections
  - verify [14](#)
- console requirement [62](#)
- controller enclosures
  - connecting to hosts [19](#)
  - connecting to remote management hosts [23](#)
- conventions, document [xii](#)

## D

- DHCP
  - server [23](#)
- direct attach configurations [19](#)
- disk
  - LEDs, 2U12 [50](#)
  - LEDs, 2U24 [48](#)
- disk drive
  - LEDs
    - general [51](#)
    - specific states [52](#)
- document
  - conventions [xii](#)
  - prerequisite knowledge [xi](#)
  - related documentation [xii](#)

## E

- electrostatic discharge [67](#)
  - grounding methods [67](#)
- enclosure
  - cabling [9](#)
  - dimensions [63](#)
  - IDs, correcting [36](#)
  - initial configuration [7](#)
  - input frequency requirement [64](#)
  - input voltage requirement [64](#)
  - installation checklist [7](#)
  - site requirements [62](#)
  - troubleshooting [36](#)
  - weight [63](#)
- environmental requirements [64](#)
  - non-operating [64](#)
  - operating [64](#)

## F

- faults
  - isolating
    - a host-side connection [42](#)
    - expansion port connection fault [43](#)
    - methodology [33](#)

## H

host ports

- FC 20

  - loop topology 20

  - point-to-point topology 20

hosts

- multipath software 19

- stopping I/O 37

- system requirements 19

humidity non-operating range 64

humidity operating range 64

## I

IDs, correcting for enclosure 36

## L

LEDs

- 2U12 front panel, disk 50

- 2U12 front panel, Enclosure ID 50

- 2U12 front panel, FRU OK 49

- 2U12 front panel, Temperature Fault 49

- 2U12 front panel, Unit Locator 49

- 2U24 front panel 47

- 2U24 front panel, disk 48

- 2U24 front panel, Enclosure ID 48

- 2U24 front panel, Fault/Service Required 47

- 2U24 front panel, FRU OK 47

- 2U24 front panel, Temperature Fault 47

- 2U24 front panel, Unit Locator 47

Disk drive

- Fault 51

disk drive

- Power/Activity 51

PSU

- Input Source Power Good 56

- Voltage/Fan Fault/Service Required 56

StorNext QX 1200/2400 enclosure rear panel layout 53

StorNext QX 1200/2400 rear panel

- Cache Status 55

- Expansion Port Status 55

- Fault/Service Required 54, 57

- FRU OK 54, 57

- Link Activity 54

- Link Status 54

- Network Port Activity 54

- Network Port Link Status 54

- OK to Remove 54, 57

- SAS In Port Status 57

- SAS Out Port Status 57

- Unit Locator 54, 57

using to diagnose fault conditions 37

local management host requirement 62

## N

NEBS (Level 3)

- Exceptions to GR-63-CORE 8

  - Airborne Contaminants 8

- Equipment - Fan Filters [8](#)
- Heat Dissipation [8](#)
- Spatial Requirements [8](#)
- GR-1089-CORE Issue 5 [8](#)
  - R3-1.159 - emission and immunity criteria [23](#)
  - R4-16.171 - suitable for intra-building cabling [61](#)
  - R9-10.79 - electrical continuity [62](#)
  - R9-16.151 - BR input terminals are DC-I [60](#)
  - R9-3.76 - suitable for installing as part of CBN [60](#)
  - R9-6.213 - suitable installation sites [62](#)
- GR-63-CORE Issue 3 [8](#)
  - R4-17.157 - fans and cooling units [4](#)
- NEBS (Network Equipment-Building System) [8](#)
- non-operating ranges, environmental [64](#)

## O

- operating ranges, environmental [64](#)

## P

- physical requirements [62](#)
- power cable requirements [65](#)
- power cycle
  - power off [16](#), [17](#)
  - power on [15](#), [17](#)
- power supply
  - AC power requirements [59](#)
  - DC power requirements [60](#)
- prerequisite knowledge [xi](#)
- PSU
  - AC [53](#)
  - DC [53](#)
  - LEDs
    - general [56](#)

## R

- rear panel
  - USB ports [69](#)
- regulatory compliance
  - additional document [59](#)
  - notices
    - shielded cables [23](#)
- related documentation [xii](#)
- remote management [23](#)
- requirements
  - cabling [61](#)
  - clearance [61](#)
  - host system [19](#)
  - physical [62](#)
  - ventilation [61](#)
- RFI/EMI connector hoods [23](#)
- rugged chassis
  - European Telco compliant [xi](#)
  - MIL-STD-810G (storage requirements) compliant [xi](#)
  - NEBS Level 3 compliant [xi](#)

## S

- safety requirements [59](#)

- sensors
  - locating [45](#)
  - PSU [45](#)
  - temperature [46](#)
  - voltage [46](#)
- shock non-operating range [64](#)
- shock operating range [64](#)
- site planning
  - AC power requirements [59](#)
  - cabling requirements [61](#)
  - clearance [61](#)
  - DC power requirements [60](#)
  - electrical requirements [64](#)
  - input voltage requirement [64](#)
  - local management host requirement [62](#)
  - physical requirements [62](#)
  - safety requirements [59](#)
  - site requirements [59](#)
  - ventilation requirements [61](#)
- site requirements [59](#)
- storage system setup
  - configuring [31](#)
  - getting started [31](#)
  - provisioning [31](#)
- supercapacitor pack [6](#)
- switch attach configurations [22](#)

## T

- temperature non-operating range [64](#)
- temperature operating range [64](#)
- troubleshooting [33](#)
  - correcting enclosure IDs [36](#)
  - enclosure does not initialize [36](#)
  - expansion port connection fault [43](#)
  - host-side connection fault [42](#)
  - using system LEDs [37](#)

## U

- ULP [19](#)
- USB device connection
  - device driver [70](#)
  - emulated serial port [70](#)
  - rear panel USB ports [69](#)
  - supported host applications [70](#)
  - vendor and product ID codes [70](#)

## V

- ventilation requirements [61](#)
- vibration non-operating range [64](#)
- vibration operating range [64](#)

## W

- warnings
  - temperature [44](#)
  - voltage [44](#)

