



Replacing a RAID Controller in Base System

StorNext QD7000

Firmware 8.40.xx.xx



Replacing a RAID Controller in Base System, 6-68668-01 Rev A, March 2018 Product of USA.

Quantum Corporation provides this publication "as is" without warranty of any kind, either express or implied, including but not limited to the implied warranties of merchantability or fitness for a particular purpose. Quantum Corporation may revise this publication from time to time without notice.

COPYRIGHT STATEMENT

© 2018 Quantum Corporation. All rights reserved.

Your right to copy this manual is limited by copyright law. Making copies or adaptations without prior written authorization of Quantum Corporation is prohibited by law and constitutes a punishable violation of the law.

TRAEMARK STATEMENT

Artico, Be Certain (and the Q brackets design), DLT, DXi, DXi Accent, DXi V1000, DXi V2000, DXi V4000, GoVault, Lattus, NDX, the Q logo, the Q Quantum logo, Q-Cloud, Quantum (and the Q brackets design), the Quantum logo, Quantum Be Certain (and the Q brackets design), Quantum Vision, Scalar, StorageCare, StorNext, SuperLoader, Symform, the Symform logo (and design), vmPRO, and Xcellis are either registered trademarks or trademarks of Quantum Corporation and its affiliates in the United States and/or other countries. All other trademarks are the property of their respective owners.

Products mentioned herein are for identification purposes only and may be registered trademarks or trademarks of their respective companies. All other brand names or trademarks are the property of their respective owners.

Quantum specifications are subject to change.



Preface

Note: The 8.40.xx.xx firmware (Madrid) is used in the QD7000 (E5600, Titan RAID controller, only). Refer to the [NetApp to Quantum Naming Decoder](#) section for additional information.

This section provides the following information:

- [Audience](#)
- [Prerequisites](#)
- [NetApp to Quantum Naming Decoder](#)
- [Product Safety Statements](#)
- [Contacts](#)
- [Comments](#)
- [Quantum Global Services](#)

Audience

This manual is intended for storage customers and technicians.

Prerequisites

Prerequisites for installing and using this product include knowledge of:



- Servers and computer networks
- Network administration
- Storage system installation and configuration
- Storage area network (SAN) management and direct attach storage (DAS)
- Fibre Channel (FC) and Ethernet protocols



NetApp to Quantum Naming Decoder

Use [Table 1](#) to correlate the NetApp product nomenclature to the equivalent Quantum-storage naming conventions.

Table 1 Product Nomenclature

E-Series NetApp Product	Quantum-Storage	Description
Controller-Drive Tray	Base System	Quantum uses Base System when referring to a drive tray with the RAID controllers.
Drive Tray	Expansion Unit	Quantum uses Expansion Unit when referring to a drive tray with the environmental services modules (ESMs).
E5600 (Code Name: Titan)	RAID Controller	Four 16Gb/s FC SFP+ host ports
E5500 (Code Name: Soyuz)	RAID Controller	Four 16Gb/s FC SFP+ host ports
E5400 (Code Name: Pikes Peak)	RAID Controller	Four 8Gb/s FC SFP+ host ports
DE6600 (Code Name: Wembley)	4U 60-drive enclosure	Sixty 3.5 inch disk drives

E-Series NetApp Product	Quantum-Storage	Description
<p>E5660</p> <ul style="list-style-type: none"> • DE6600 4U drive enclosure • With E5600 RAID controllers (Titan) 	<p>Quantum StorNext QD7000</p>	
<p>E5560</p> <ul style="list-style-type: none"> • DE6600 4U drive enclosure • With E5500 RAID controllers (Soyuz) 	<p>Quantum StorNext QD7000</p>	
<p>E5460</p> <ul style="list-style-type: none"> • DE6600 4U drive enclosure • With E5400 RAID controllers (Pikes Peak) 	<p>Quantum StorNext QD6000</p>	

E-Series NetApp Product	Quantum-Storage	Description
<p>E5424</p> <ul style="list-style-type: none"> • DE5600 24-drive 2U drive enclosure • Code Name: Camden • With E5400 RAID controllers (Pikes Peak) 	<p>Quantum StorNext QS2400</p>	
<p>E5412</p> <ul style="list-style-type: none"> • DE1600 12-drive 2U drive enclosure • Code Name: Ebbets • With E5400 RAID controllers (Pikes Peak) 	<p>Quantum StorNext QS1200</p>	

Product Safety Statements

Quantum will not be held liable for damage arising from unauthorized use of the product. The user assumes all risk in this aspect.

This unit is engineered and manufactured to meet all safety and regulatory requirements. Be aware that improper use may result in bodily injury, damage to the equipment, or interference with other equipment.

WARNING: Before operating this product, read all instructions and warnings in this document and in the system, safety, and regulatory guide.

警告 在使用本产品之前，请先阅读本文档及系统、安全和法规信息指南中所有的说明和警告信息。

警告 操作本产品前，请先阅读本文件及系统、安全与法规资讯指南中的指示与警告说明。

ADVERSAL Læs alle instruktioner og advarsler i dette dokument og i *Vejledning om system-sikkerheds- og lovgivningsoplysninger*, før produktet betjenes.

AVERTISSEMENT Avant d'utiliser ce produit, lisez la totalité des instructions et avertissements de ce document et du *Guide d'informations sur le système, la sécurité et la réglementation*.

HINWEIS Lesen Sie vor der Verwendung dieses Produkts alle Anweisungen und Warnhinweise in diesem Dokument und im System, Safety, and Regulatory Information Guide (Info-Handbuch: System, Sicherheit und Richtlinien).

אזהרה לפני ההפעלה של מוצר זה, קרא את כל ההוראות והאזהרות הכלולות במסמך זה וכן במדריך מידע בנושאי מערכת, בטיחות ותקינה

警告 この製品を使用する前に、本文書、および『システム、安全、規制に関する情報ガイド』に記載しているすべての警告と指示をお読みください。

경고 이 제품을 작동하기 전에 이 문서 및 시스템, 안전, 및 규제 정보 안내서에 수록된 모든 지침과 경고 표지를 숙지하십시오.

ПРЕДУПРЕЖДЕНИЕ

Перед началом эксплуатации данного устройства ознакомьтесь во всеми инструкциями и предупреждениями, приведенными в данном документе и в *Справочном руководстве по устройству, технике безопасности и действующим нормативам*.

ADVERTENCIA

Antes de utilizar este producto, lea todas las instrucciones y advertencias en este documento y en la Guía informativa sobre sistema, seguridad y normas.

WARNING

Läs alla anvisningar och varningar i detta dokument och i *System, säkerhet och krav från myndigheter - Informationshandbok* innan denna produkt tas i bruk.

Contacts

For information about contacting Quantum, including Quantum office locations, go to:

<http://www.quantum.com/aboutus/contactus/index.aspx>

Comments

To provide comments or feedback about this document, or about other Quantum technical publications, send e-mail to:

doc-comments@quantum.com

Quantum Global Services

Accelerate service issue resolution with these exclusive Quantum StorageCare services:

- **Service and Support Website** - Register products, license software, browse Quantum Learning courses, check backup software and operating system support, and locate manuals, FAQs, firmware downloads, product updates and more in one convenient location. Benefit today at:

<http://www.quantum.com/serviceandsupport/get-help/index.aspx#contact-support>

- **eSupport** - Submit online service requests, update contact information, add attachments, and receive status updates via email. Online Service accounts are free from Quantum. That account can

also be used to access Quantum's Knowledge Base, a comprehensive repository of product support information. Get started at:

<http://www.quantum.com/customercenter/>

For further assistance, or if training is desired, contact the Quantum Customer Support Center:

North America	1-800-284-5101 (toll free) +1-720-249-5700
EMEA	+800-7826-8888 (toll free) +49-6131-324-185
APAC	+800-7826-8887 (toll free) +603-7953-3010

For worldwide support:

<http://www.quantum.com/serviceandsupport/get-help/index.aspx#contact-support>



NetApp®

Replacing a Failed Controller Canister in the E5660 Controller-Drive Tray

To access this product, go to the NetApp® support site at mysupport.netapp.com.

You can determine whether you have a failed controller canister in two ways:

- The Recovery Guru directs you to replace a failed controller canister.
- The amber Controller Service Action Required LED indicates a failed controller canister.

Before you replace the controller canister, gather antistatic protection, a new controller canister, and a controller air blocker.

When you install a new controller, you must remove the battery from the failed controller, and install it in the new controller. This procedure includes that task.

ATTENTION Possible loss of data access – Your new controller must have the same host interface card (HIC) as the controller you are replacing. If the HICs do not match, do not attempt this procedure. The presence of mismatched controllers causes your storage array to lock down when you bring the new controller on line. You lose access to your data until the problem is corrected.

ATTENTION Possible loss of data access – If the controller that you are replacing manages any secure volumes, the new controller needs the correct security key to manage those volumes. After you replace the controller and restore power to the controller-drive tray, you can use SANtricity® Storage Manager to load the key from the file in which it was saved. Be sure that such a file exists and that you know the pass phrase required to install the security key before you replace the controller.

ATTENTION Possible hardware damage – Because you perform this procedure with the power turned on, the equipment might overheat if the controller slot is left open for more than three minutes. To prevent the possibility of overheating, you must insert the controller air blocker into the controller slot when you service the controller.

Figure 1. E5660 Controller-Drive Tray

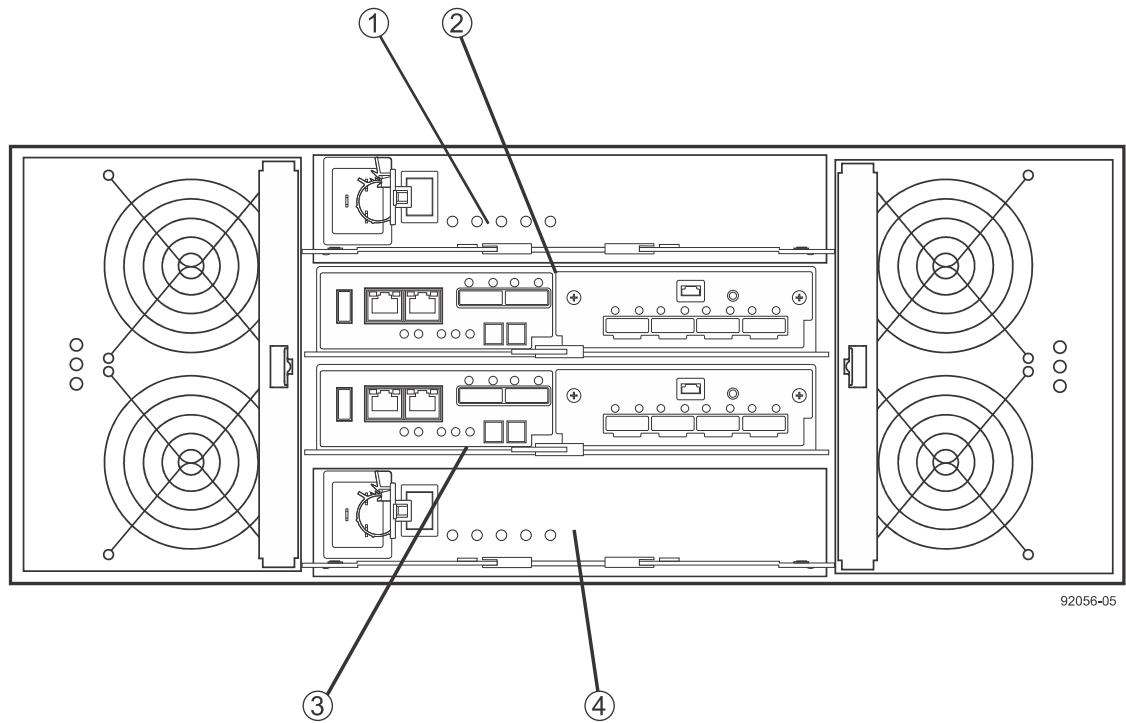

1. Power Canister A
2. Controller Canister A
3. Controller Canister B
4. Power Canister B

Removing a Controller Canister from the E5660 Controller-Drive Tray

ATTENTION Possible hardware damage – To prevent electrostatic discharge damage to the tray, use proper antistatic protection when handling tray components.

ATTENTION Possible extended outage – You must replace the controller with the power turned on to ensure auto-code synchronization of the native controller firmware to the new controller and to prevent the possibility of an extended outage.

1. Gather support data about your storage array by using one of these methods:
 - Use the storage management software to collect and save a support bundle of your storage array. From the Array Management Window toolbar, select **Monitor > Health > Collect Support Data Manually**. Then name and specify a location on your system where you want to store the support bundle.
 - Use the command line interface (CLI) to run the `save storageArray supportData` command to gather comprehensive support data about the storage array.

For more information about this command, refer to the current version of the *Command Line Interface and Script Commands Programming Guide*.

NOTE Gathering support data can temporarily impact performance on your storage array.

2. Did the Recovery Guru direct you to replace a failed controller canister?
 - **Yes** – Go to step [3](#).
 - **No** – Run the Recovery Guru to identify the failed controller canister, and then go to step [3](#).
3. Locate the failed controller canister by checking the Controller Service Action Required LEDs shown in the following figure.

If a fault is detected, the amber Controller Service Action Required LED is on. You can safely remove the controller canister when the blue Controller Service Action Allowed LED is on.

NOTE Your controller canister might have a different number and type of host interface connectors than what is shown in the following figure.

Figure 2. E5600 Controller Service Action LEDs

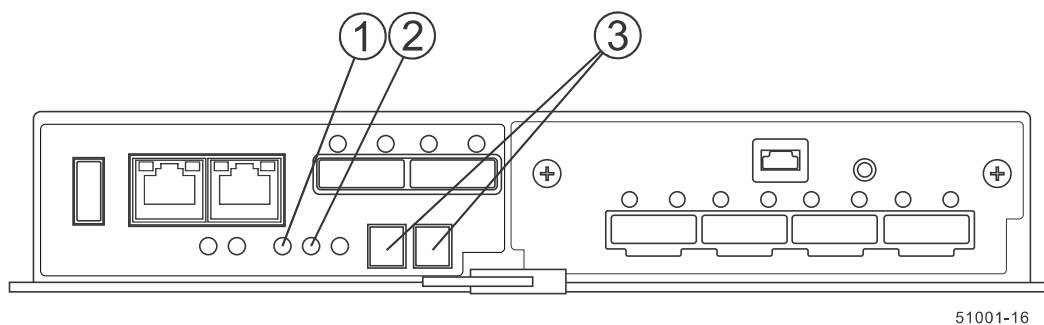

1. Controller Service Action Allowed LEDs (Blue)
 2. Controller Service Action Required LEDs (Amber)
 3. Seven-Segment Display
4. Record the information from the seven-segment display on the rear of the controller-drive tray.

The display flashes a sequence of codes. To find information about the displayed diagnostic codes, refer to the *E5600 Controller-Drive Tray and Related Drive Trays Installation Guide*.
 5. Is the Controller Service Action Allowed LED to on?
 - **Yes** – Go to step [8](#).
 - **No** – Go to step [6](#).
 6. Use either the GUI (first bullet) or the CLI (second bullet) to take the appropriate controller offline.
 - From the **Hardware** pane in the **Array Management Window**, right-click the picture of the controller that you want to take offline, and then select **Advanced** > **Place** > **Offline**.
 - Run the following command:

```
smCLI <DNS-network-name-or-IP-address> -c
"set controller [(a | b)] availability=offline";
```
 7. Wait for the Controller Service Action Allowed LED to come on.

This indication might take several minutes for a large configuration.
 8. Put on antistatic protection.

ATTENTION Potential degraded performance – To prevent degraded performance, do not twist, fold, pinch, or step on the cables. Many cables have a minimum bending radius. Check the specifications for your cables, and do not bend any cable more tightly than the minimum specified radius.

9. Label each of the interface cables and Ethernet cables attached to the controller canister so that you can reconnect each cable correctly after you reinstall the controller canister.
10. Disconnect all of the interface cables and Ethernet cables from the failed controller canister without disturbing the other canister.
11. If the failed controller canister contains a Fibre Channel HIC or an InfiniBand HIC, remove the small form-factor pluggable (SFP) transceivers (for Fibre Channel) or quad SFP (QSFP) transceivers (for InfiniBand) from the HIC and save them for possible reuse.
12. Prepare the controller air blocker by removing it from its packaging and folding it inward at right angles so it is ready to insert into the open controller slot.

Figure 3. Controller Air Blocker

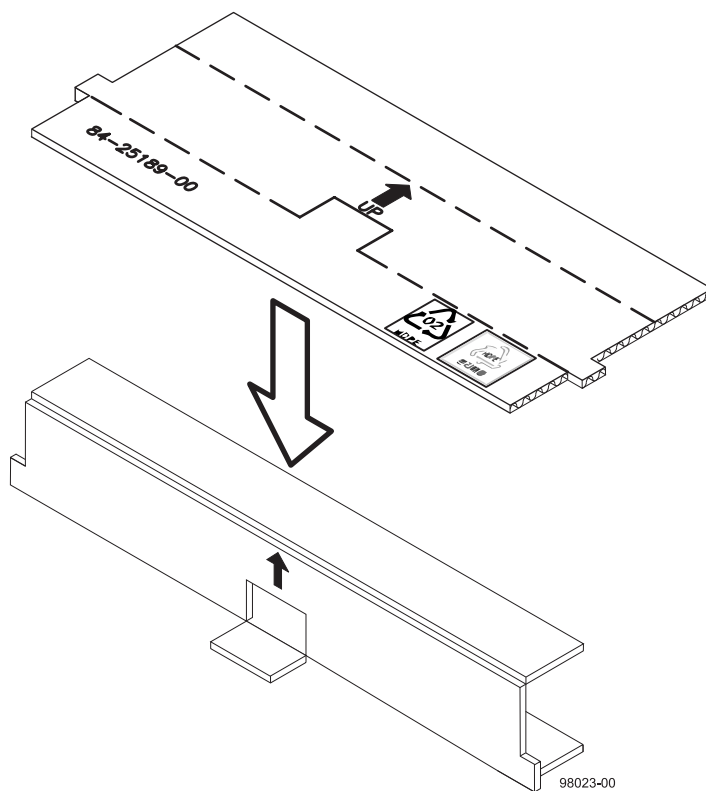

13. Remove the failed controller canister.

NOTE The following figures show the controller in the bottom position within the controller-drive tray. However, you might be removing the controller and inserting the controller air blocker in the top position. The required actions are similar.

- a. Unlock and pull out the release levers to release the controller canister.

- b. Using the release levers and your hands, pull the controller canister out of the controller-drive tray.

Figure 4. Removing and Replacing a Controller Canister

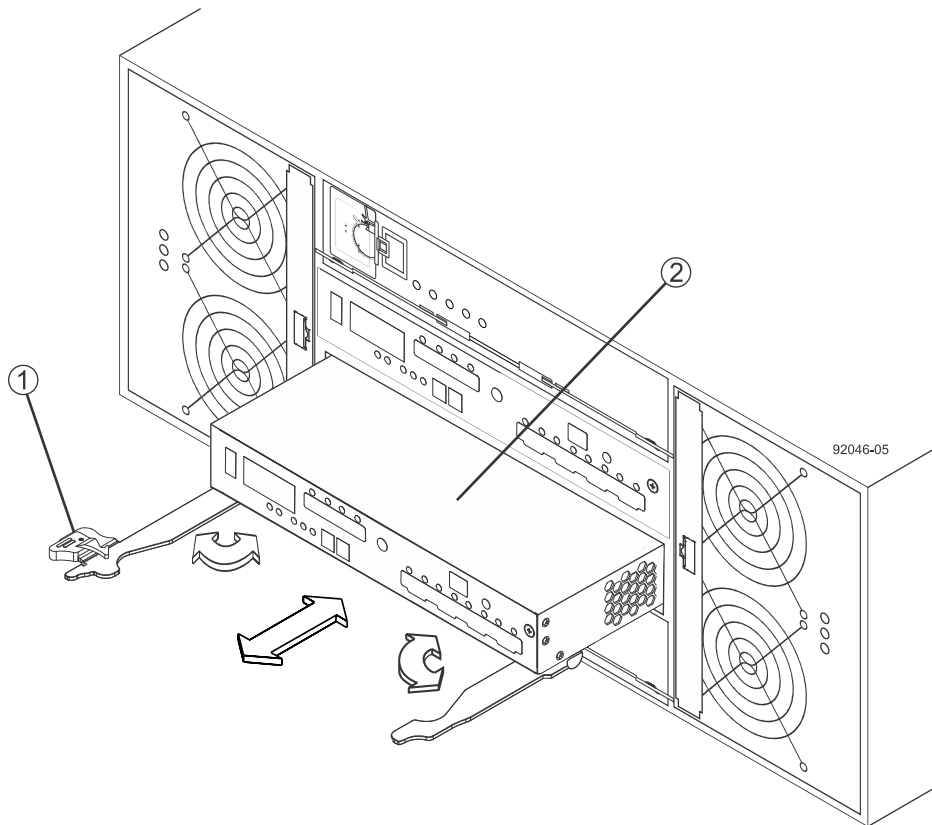

1. Release Levers
2. Controller Canister

- c. Set the failed controller canister on a flat, static-free surface with the release levers up.

ATTENTION Possible hardware damage – Because you perform this procedure with the power turned on, the equipment might overheat if the controller slot is left open for more than three minutes. To prevent the possibility of overheating, you must insert the controller air blocker into the controller slot when servicing the controller.

14. Insert the controller air blocker into the open controller slot to make sure that proper airflow is maintained.

Figure 5. Inserting the Controller Air Blocker into the Open Controller Slot

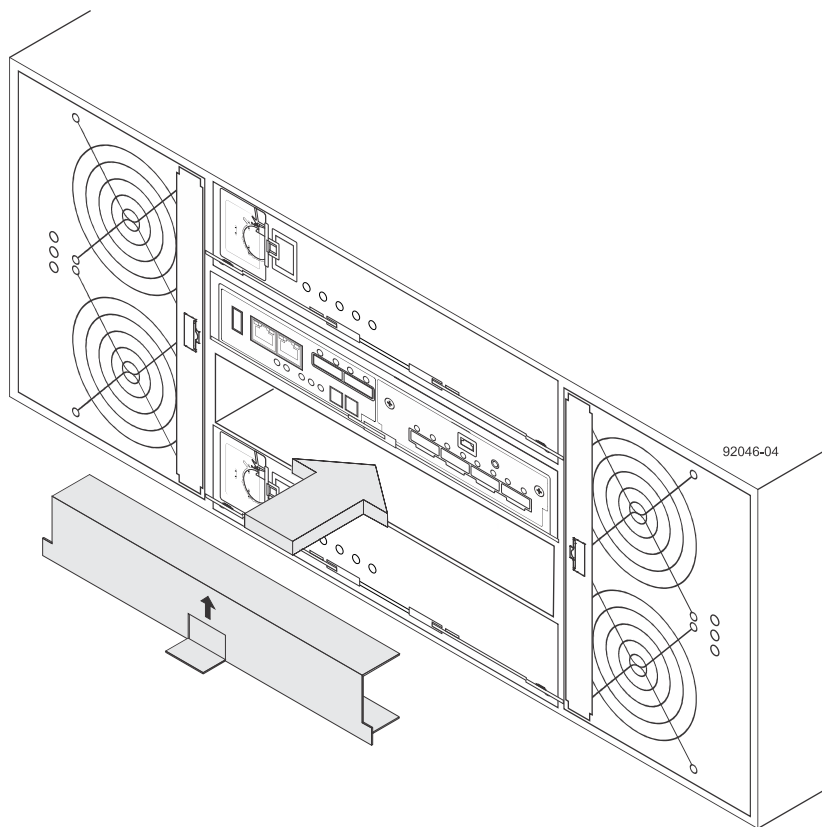

15. Remove the battery from the failed controller canister by performing these steps:

- a. Press down on both of the top cover latch buttons as you slide the top cover off the controller canister.

- b. Move the battery locking tab down to pull the battery out of the controller canister.

Figure 6. Controller Cover and Internal Parts

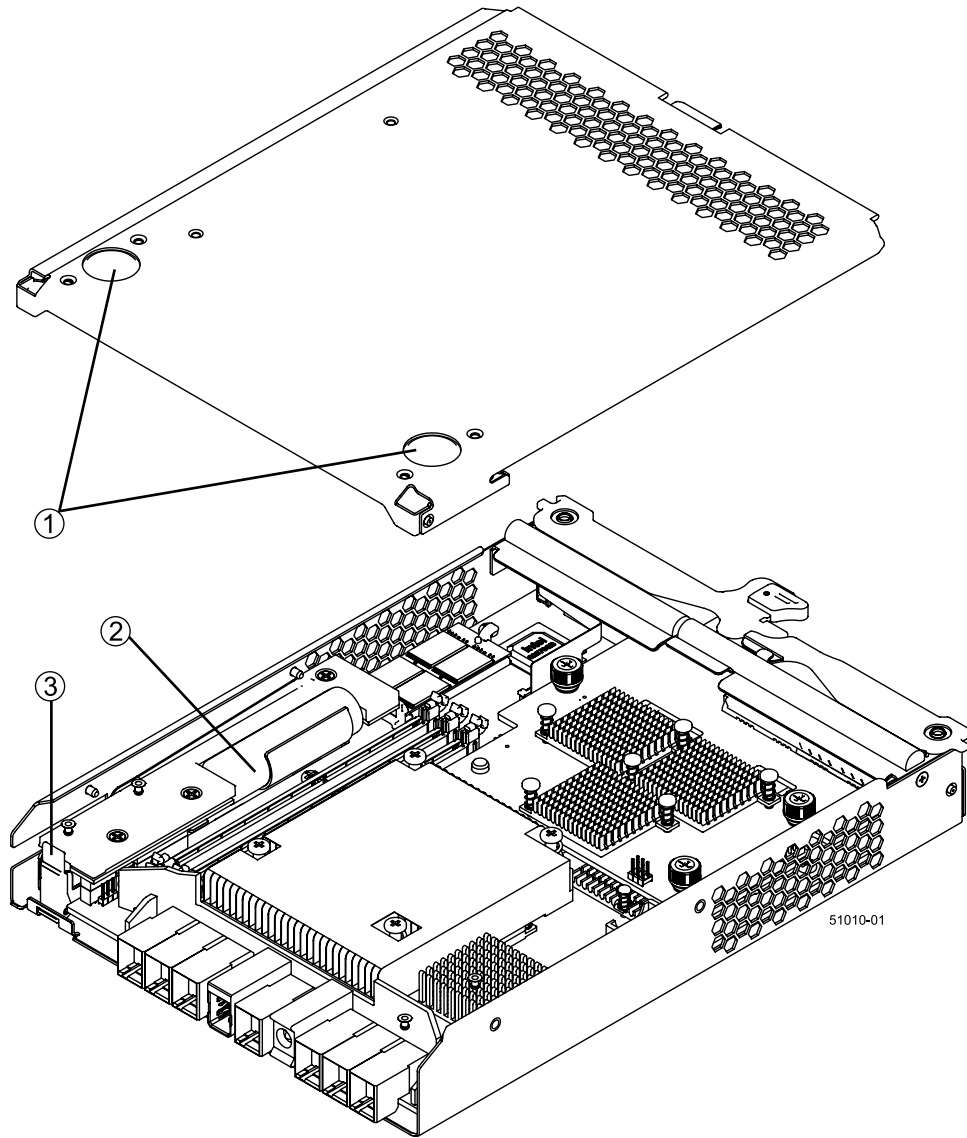

1. Top Cover Latch Buttons
2. Battery Circuit Board
3. Battery Locking Tab

- c. Remove the controller battery by sliding it towards the rear of the failed controller canister.

Installing a Controller Canister in the E5600 Controller-Drive Trays

1. Unpack the new controller canister.
 - a. Set the new controller canister on a flat, static-free surface near the controller-drive tray with the top cover up.
 - b. Save all of the packing materials so that you can ship the failed controller canister.

2. Push down the two top cover latch buttons that secure the top cover to the new controller canister.
3. Remove the top cover by sliding it to the rear of the new controller canister.
4. Insert the battery at a slight downward angle into the controller canister. Slide the battery towards the front of the controller canister, making sure that the battery slides under the side guide pins as you continue to slide the battery to correctly seat it against the back surface.

ATTENTION If the battery is not correctly seated, you cannot reinstall the top cover on the controller canister as directed later. To make sure that the controller battery is seated correctly, you might need to slide it out and insert it again. You will know it is secure when you hear it click into place, and the locking handle does not move out of its upright position when you wiggle it.

5. Move the locking tab up to secure the new battery circuit board to the controller canister.
6. Reinstall the top cover on the new controller canister by sliding the top cover forward until the top cover latch buttons click.
7. Remove the controller air blocker from the controller slot.
8. Slide the new controller canister all the way into the controller-drive tray. Rotate the release levers towards the center of the controller canister to lock it into place.
9. If you removed SFP transceivers (for Fibre Channel) or the QSFP transceivers (for InfiniBand) from the HIC in the old controller canister, install them in the new controller canister.
10. Reconnect all of the cables that you disconnected.
11. Use either the GUI (first bullet) or the CLI (second bullet) to bring the controller online.
 - From the Hardware pane in the Array Management Window, right-click the picture of the controller, and select **Advanced > Place > Online**.
 - Run the following command:

```
smCLI <DNS-network-name-or-IP-address> -c "set controller [(a | b)] availability=online";
```

Checking the New E5600 Controller Canister

1. Look at the LEDs on the new controller canister to make sure that the new controller is booting correctly. The Host Link Service Action Required LEDs turn green during the reboot. The seven-segment display shows the sequence OS+ Sd+ blank- to indicate that the controller is performing Start-of-day (SOD) processing. After the controller successfully completes rebooting, the seven-segment display shows the tray ID matching the

seven-segment display on the second controller. You can then discover the new controller canister by using the storage management software.

Figure 7. LED Status and Seven-Segment Display

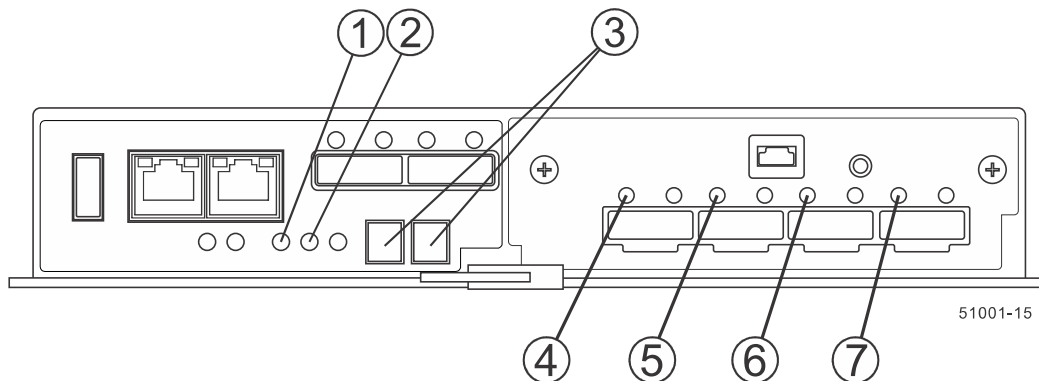

1. Controller Service Action Allowed LED (Blue)
 2. Controller Service Action Required LED (Amber)
 3. Seven-Segment Display
 4. Host Link 1 Service Action Required LED (Amber)
 5. Host Link 2 Service Action Required LED (Amber)
 6. Host Link 3 Service Action Required LED (Amber)
 7. Host Link 4 Service Action Required LED (Amber)
2. Look at the Controller Service Action Required LEDs. Based on the LED status, perform one of these actions:
 - **All of the amber Service Action Required LEDs are off, and the Array Management Window indicates an Optimal status** – Go to step [5](#).
 - **Any of the controller-drive tray's Service Action Required LEDs are on, or the Controller Service Action Required LED is on** – Check that the controller canister has been installed correctly and that all of the cables are correctly seated. Reinstall the controller canister, if necessary. Go to step [4](#).
 3. Did this action correct the problem?
 - **Yes** – Go to step [5](#).
 - **No** – If the problem is not resolved, contact your Technical Support Representative.
 4. Using the LEDs and the storage management software, check the status of all of the trays in the storage array.
 5. Does any component have a Needs Attention status?
 - **Yes** – Click the Recovery Guru toolbar button in the **Array Management Window**, and complete the recovery procedure. If the problem is not resolved, contact your Technical Support Representative.
 - **No** – Go to step [7](#).
 6. Remove the antistatic protection.
 7. Gather support data about your updated storage array by using one of these methods:
 - Use the storage management software to collect and save a support bundle of your storage array. From the Array Management Window toolbar, select **Monitor > Health > Collect Support Data Manually**. Then name and specify a location on your system where you want to store the support bundle.
 - Use the CLI to run the `save storageArray supportData` command to gather comprehensive support data about the storage array.

For more information about the CLI command, refer to the current version of the *Command Line Interface and Script Commands Programming Guide*.

NOTE Gathering support data can temporarily impact performance on your storage array.

Trademark information

NetApp, the NetApp logo, Network Appliance, the Network Appliance logo, Akorri, ApplianceWatch, ASUP, AutoSupport, BalancePoint, BalancePoint Predictor, Bycast, Campaign Express, ComplianceClock, Cryptainer, CryptoShred, CyberSnap, Data Center Fitness, Data ONTAP, DataFabric, DataFort, Decru, Decru DataFort, DenseStak, Engenio, Engenio logo, E-Stack, ExpressPod, FAServer, FastStak, FilerView, Flash Accel, Flash Cache, Flash Pool, FlashRay, FlexCache, FlexClone, FlexPod, FlexScale, FlexShare, FlexSuite, FlexVol, FPolicy, GetSuccessful, gFiler, Go further, faster, Imagine Virtually Anything, Lifetime Key Management, LockVault, Manage ONTAP, Mars, MetroCluster, MultiStore, NearStore, NetCache, NOW (NetApp on the Web), Onaro, OnCommand, ONTAPI, OpenKey, PerformanceStak, RAID-DP, ReplicatorX, SANscreen, SANshare, SANtricity, SecureAdmin, SecureShare, Select, Service Builder, Shadow Tape, Simplicity, Simulate ONTAP, SnapCopy, Snap Creator, SnapDirector, SnapDrive, SnapFilter, SnapIntegrator, SnapLock, SnapManager, SnapMigrator, SnapMirror, SnapMover, SnapProtect, SnapRestore, Snapshot, SnapSuite, SnapValidator, SnapVault, StorageGRID, StoreVault, the StoreVault logo, SyncMirror, Tech OnTap, The evolution of storage, Topio, VelocityStak, vFiler, VFM, Virtual File Manager, VPolicy, WAFL, Web Filer, and XBB are trademarks or registered trademarks of NetApp, Inc. in the United States, other countries, or both.

IBM, the IBM logo, and ibm.com are trademarks or registered trademarks of International Business Machines Corporation in the United States, other countries, or both. A complete and current list of other IBM trademarks is available on the web at <http://www.ibm.com/legal/copytrade.shtml>.

Apple is a registered trademark and QuickTime is a trademark of Apple, Inc. in the United States and/or other countries. Microsoft is a registered trademark and Windows Media is a trademark of Microsoft Corporation in the United States and/or other countries. RealAudio, RealNetworks, RealPlayer, RealSystem, RealText, and RealVideo are registered trademarks and RealMedia, RealProxy, and SureStream are trademarks of RealNetworks, Inc. in the United States and/or other countries.

All other brands or products are trademarks or registered trademarks of their respective holders and should be treated as such.

NetApp, Inc. is a licensee of the CompactFlash and CF Logo trademarks.

NetApp, Inc. NetCache is certified RealSystem compatible.

How to send your comments

You can help us to improve the quality of our documentation by sending us your feedback.

Your feedback is important in helping us to provide the most accurate and high-quality information. If you have suggestions for improving this document, send us your comments by email to doccomments@netapp.com. To help us direct your comments to the correct division, include in the subject line the product name, version, and operating system.

You can also contact us in the following ways:

- NetApp, Inc., 495 East Java Drive, Sunnyvale, CA 94089 U.S.
- Telephone: +1 (408) 822-6000

- Fax: +1 (408) 822-4501
- Support telephone: +1 (888) 463-8277