

**ATL M-Series**  
**User's Guide**

**6423002-04 A01**

**Quantum.**

ATL M-Series User's Guide, 6423002-04 A01, September 2003, Made in USA.

Quantum Corporation provides this publication "as is" without warranty of any kind, either express or implied, including but not limited to the implied warranties of merchantability or fitness for a particular purpose. Quantum Corporation may revise this publication from time to time without notice.

### **COPYRIGHT STATEMENT**

Copyright 2003 by Quantum Corporation. All rights reserved.

Your right to copy this manual is limited by copyright law. Making copies or adaptations without prior written authorization of Quantum Corporation is prohibited by law and constitutes a punishable violation of the law.

### **TRADEMARK STATEMENT**

StackLink is a trademark of Quantum Corporation.

Other trademarks may be mentioned herein which belong to other companies.

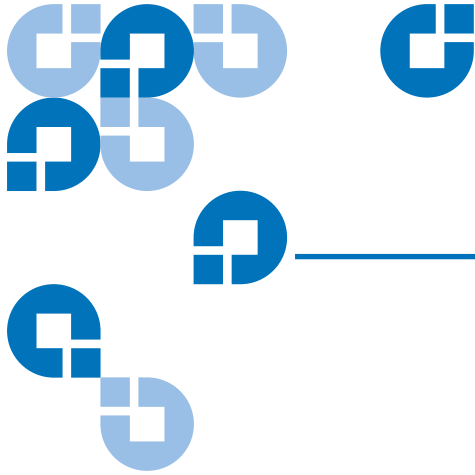

# Contents

---

---

<b>Preface</b>	<b>xiii</b>
----------------	-------------

---

<b>Chapter 1</b>	<b>Overview</b>	<b>1</b>
	Library Capacity.....	1
	ATL M1500 Library .....	1
	ATL M2500 Library .....	1
	Tape Drives .....	2
	Library Scalability .....	2
	Library Features .....	5
	Front Panel.....	5
	Internal Layout.....	8
	Back Panel.....	10

---

<b>Chapter 2</b>	<b>Basic Operations</b>	<b>13</b>
	Introduction .....	14
	Main Screen .....	14
	GUI Buttons .....	17
	GUI Icons .....	17

Using the Quick View Menu Screen.....	19
Accessing the Quick View Menu Screen .....	19
Viewing Library Information .....	20
Viewing Tape Drive Information.....	21
Viewing Inventory Information.....	22
Turning Drive Power On or Off (Quick View Menu Screen) .....	23
Moving Tape Cartridges .....	25
Using the Mailbox .....	28
Viewing Mailbox Status .....	29
Importing and Exporting Cartridges .....	29
Configuring the Mailbox.....	34
Removing the Magazines .....	35
Removing a Magazine from an ATL M1500 .....	35
Removing a Magazine from an ATL M2500 .....	38
Viewing Statistics .....	42
Accessing the Statistics Menu Screen .....	42
Viewing Library Statistics .....	44
Viewing Drive Statistics .....	45
Viewing the SCSI History .....	46
Viewing the Stack Configuration.....	47

---

<b>Chapter 3</b>	<b>Changing the Library Configuration</b>	<b>49</b>
------------------	---	-----------

Accessing the Configuration Screen .....	49
Setting the Library ID .....	51
Changing a Tape Drive ID .....	51
Changing the Terminator Power Setting .....	53
Changing the Emulation Setting .....	54
Changing the Storage Slot Count Setting .....	55
Changing the Sync Negotiation Setting .....	56
Changing the Wide Negotiation Setting .....	57
Changing the Serialization Setting .....	58
Changing the Short Labels Setting.....	58
Changing the Illumination Setting .....	59
Changing the Off-Line Time Setting .....	60
Changing the Barcode Scanner Setting .....	61
Changing the Baud Rate Setting .....	62
Setting the Time .....	62
Setting the Date.....	63
Changing the Import/Export Setting.....	64

	Changing the Auto-Clean Setting.....	66
	Changing the Ignore Host Lock Setting .....	67
	Changing the Auto-Import Option .....	68
<b>Chapter 4</b>	<b>Performing Maintenance Operations</b>	<b>69</b>
	Accessing the Maintenance Screen.....	69
	Cleaning a Tape Drive.....	71
	Turning Drive Power On or Off (Maintenance Screen) .....	73
	Turning Drive Power On or Off in an ATL M1500 Library .....	73
	Turning Drive Power On or Off in an ATL M2500 Library .....	74
	Adjusting the Contrast.....	75
<b>Chapter 5</b>	<b>Running Diagnostic Programs</b>	<b>77</b>
	Accessing the Diagnostics Menu Screen.....	77
	Running the Barcode Scanner Test.....	79
	Running the Move Medium Test.....	81
	Running the Move Location Test.....	84
	Running the Display Test .....	87
<b>Chapter 6</b>	<b>Updating Drive Firmware</b>	<b>89</b>
	Accessing the Service Drive Screen.....	89
	Updating the Drive Firmware from Tape .....	91
<b>Chapter 7</b>	<b>Running the Demonstration Programs</b>	<b>93</b>
	Accessing the Demo Programs Screen.....	93
	Running the Confidence Test Program .....	94
	Running the Demo 1 Program .....	95
	Running the Demo 2 Program .....	96
	Running the Demo 3 Program .....	97
	Running the Demo 4 Program .....	98
	Running the Demo 5 Program .....	99
	Running the Demo 6 Program .....	100

---

<b>Appendix A</b>	<b>Specifications</b>	<b>101</b>
	Physical Specifications.....	102
	Performance Specifications.....	104
	Reliability Specifications .....	106
	Tape Drive Specifications.....	106
	Environmental Specifications.....	107
	SCSI Specifications .....	108

---

<b>Appendix B</b>	<b>Fault Symptom Code (FSC) Dictionary</b>	<b>109</b>
-------------------	--	------------

---

<b>Appendix C</b>	<b>DLTtape Cartridge Maintenance</b>	<b>161</b>
	Handling DLTtape Cartridges.....	161
	Visual Inspection of DLTtape Cartridges .....	162
	When To Visually Inspect a DLTtape Cartridge .....	162
	Visual Inspection Procedure.....	162

---

<b>Appendix D</b>	<b>Regulatory Statements</b>	<b>167</b>
-------------------	------------------------------	------------

---

<b>Glossary</b>		<b>199</b>
-----------------	--	------------

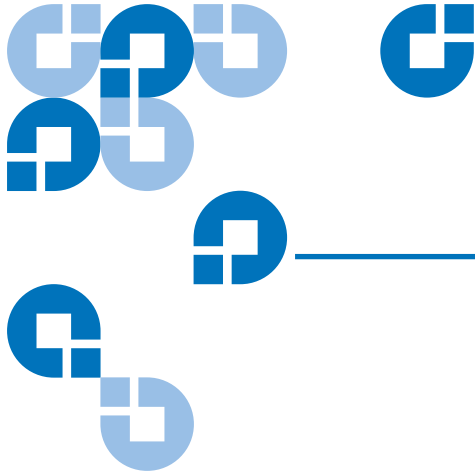

# Figures

---

Figure 1	ATL M1500 Front Panel.....	5
Figure 2	ATL M2500 Front Panel.....	6
Figure 3	ATL M1500 Internal Layout.....	8
Figure 4	ATL M2500 Internal Layout.....	9
Figure 5	ATL M1500 Back Panel.....	10
Figure 6	ATL M2500 Back Panel.....	11
Figure 7	Sample Main Screen, Stand-alone ATL M1500 .....	15
Figure 8	Sample Main Screen, ATL M1500 in a Multiple Library Stack .....	15
Figure 9	ATL M2500 Library Levels .....	16
Figure 10	Sample Main Screen, ATL M2500 .....	16
Figure 11	Using the GUI Buttons.....	17
Figure 12	Quick View Menu Screen.....	19
Figure 13	Sample Library Information Screen.....	20
Figure 14	Sample Drive Information Screen.....	21
Figure 15	Sample Inventory Screen.....	22
Figure 16	Sample Tape Drive Power Screen.....	23
Figure 17	Sample Drive Power Screen.....	24

Figure 18	Menu Screen .....	25
Figure 19	Sample Move Cartridge FROM Screen.....	26
Figure 20	Sample Move Cartridge TO Screen.....	27
Figure 21	Sample Confirm Move Cartridge Screen .....	27
Figure 22	Sample Mailbox Screen .....	28
Figure 23	Mailbox - OPEN Screen .....	30
Figure 24	Sample Release Magazines Screen .....	36
Figure 25	Magazine Release Button.....	37
Figure 26	Release Magazines Screen .....	38
Figure 27	Removing the Level 2 Left Magazine .....	40
Figure 28	Release Latch .....	41
Figure 29	Removing the Level 1 Left Magazine .....	41
Figure 30	Service Menu Screen .....	43
Figure 31	Statistics Menu Screen.....	43
Figure 32	Sample Library Statistics Screen.....	44
Figure 33	Sample Drive Statistics Screen .....	45
Figure 34	Sample SCSI History Screen.....	46
Figure 35	Sample Stack Configuration Screen .....	47
Figure 36	Menu Screen .....	50
Figure 37	Configuration Screen.....	50
Figure 38	ATL M2500 Drive Numbering.....	52
Figure 39	Service Menu Screen .....	70
Figure 40	Maintenance Screen.....	70
Figure 41	Sample Select Cleaning Cartridge Screen .....	71
Figure 42	Sample Select Tape Drive Screen.....	72
Figure 43	Sample Tape Drive Power Screen .....	73
Figure 44	Drive Power Screen .....	74
Figure 45	Adjust Contrast Screen.....	75
Figure 46	Service Menu Screen .....	78
Figure 47	Diagnostics Menu Screen.....	78



Figure 48 Diags: General Screen ..... 79

Figure 49 Diag: Barcode Screen ..... 80

Figure 50 Sample Move Cartridge FROM Screen ..... 81

Figure 51 Sample Move Cartridge TO Screen ..... 82

Figure 52 Sample Confirm Move Cartridge Screen ..... 83

Figure 53 Diag: Move Medium Screen ..... 83

Figure 54 Sample Diag: Move-Location Screen..... 85

Figure 55 Diag: Move Location Screen ..... 86

Figure 56 Service Menu Screen ..... 90

Figure 57 Service Drive Screen..... 90

Figure 58 Select Firmware Cartridge Screen..... 91

Figure 59 Select Tape Drive Screen ..... 92

Figure 60 Demo Programs Screen ..... 94

Figure 61 Location of the Reel Locks and the Hub ..... 163

Figure 62 Opening the Tape Cartridge Door ..... 164

Figure 63 Write Protect Switch ..... 165

Figure 64 Declaration of Conformity, ATL M1500 ..... 196

Figure 65 Declaration of Conformity, ATL M2500 ..... 197



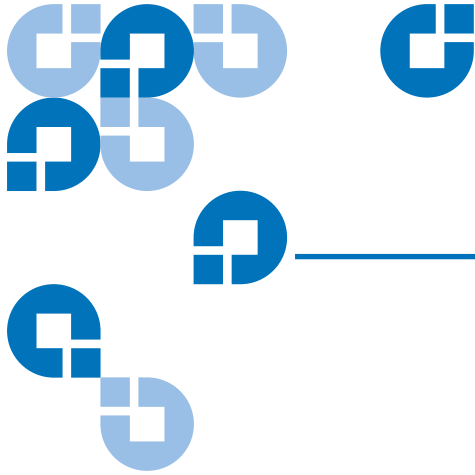

# Tables

---

Table 1	Capacity, ATL M1500 Multiple Library Stack .....	3
Table 2	Capacity, ATL M2500 Multiple Library Stack .....	4
Table 3	Front Panel Features .....	7
Table 4	GUI Icons .....	17
Table 5	Import/Export Settings .....	64
Table 6	Unit Dimensions/Weight .....	102
Table 7	Capacities.....	102
Table 8	Performance Specifications .....	104
Table 9	Library Performance .....	104
Table 10	Reliability Specifications .....	106
Table 11	Tape Drive Specifications.....	106
Table 12	Power .....	107
Table 13	Climate.....	107
Table 14	Compliance and Certification.....	107
Table 15	Fault Symptom Codes .....	109



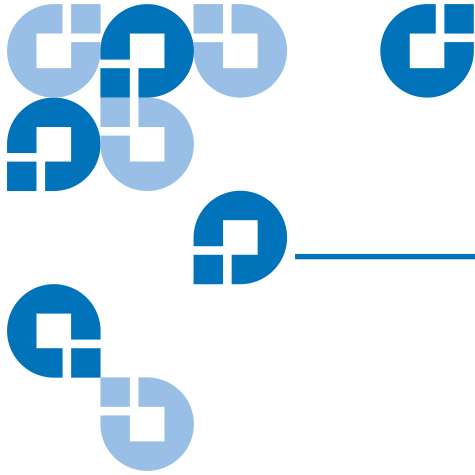

# Preface

---

---

## Audience

This document is written for operators of the ATL M1500 and ATL M2500 libraries.

---

## Purpose

This document explains how to use the ATL M1500 and ATL M2500 libraries.

---

## Document Organization

This document is organized as follows:

- [Chapter 1, Overview](#), provides an overview of the ATL M-Series libraries.
- [Chapter 2, Basic Operations](#), introduces the library GUI screens and explains how to use them to perform basic library operations such as moving tape cartridges within the library, removing the tape cartridge magazines, and viewing library information.
- [Chapter 3, Changing the Library Configuration](#), explains how to change the library configuration using the GUI **Configuration** screen.
- [Chapter 4, Performing Maintenance Operations](#), explains how to perform library maintenance operations using the GUI **Maintenance** screen.

- [Chapter 5, Running Diagnostic Programs](#), explains how to use the library's built in diagnostic programs.
- [Chapter 6, Updating Drive Firmware](#), explains how to update drive firmware from tape.
- [Chapter 7, Running the Demonstration Programs](#), explains how to run the library demonstration programs.
- [Appendix A, Specifications](#), lists the specifications for the ATL M-Series libraries.
- [Appendix B, Fault Symptom Code \(FSC\) Dictionary](#), lists the fault symptom codes (FSCs) for the ATL M-Series libraries.
- [Appendix C, DLTape Cartridge Maintenance](#), provides guidelines for handling DLT cartridges and visually inspecting them if necessary.
- [Appendix D, Regulatory Statements](#), provides regulatory information for the ATL M-Series libraries.

This document concludes with a glossary and a detailed index.

---

## Notational Conventions

This manual uses the following conventions:

**Note:** Notes emphasize important information related to the main topic.

**Tech Tip:** Tech Tips provide technical information which may be helpful in performing the procedure.

**Caution:** Cautions indicate potential hazards to equipment and are included to prevent damage to equipment.

**Warning:** Warnings indicate potential hazards to personal safety and are included to prevent injury.

This manual uses the following:

- Right side of the library – Refers to the right side as you face the component being described.
- Left side of the library – Refers to the left side as you face the component being described.

**Related Documents**

Documents related to the ATL M-Series libraries are shown below:

**ATL M-Series Documentation**

<b>Document No.</b>	<b>Title</b>	<b>Description</b>
6421002	<i>ATL M1500 Unpacking Instructions</i>	This document explains how to remove the ATL M1500 library from the shipping carton.
6423000	<i>ATL M2500 Unpacking Instructions</i>	This document explains how to remove the ATL M2500 library from the shipping carton.

<b>Document No.</b>	<b>Title</b>	<b>Description</b>
6423001	<i>ATL M-Series Installation Guide</i>	This document explains how to install an ATL M-Series library.
6421009	<i>ATL StackLink Installation Instructions</i>	This document explains how to install a multiple library stack, including: <ul style="list-style-type: none"> <li>• Installing the StackLink mechanism in the rack</li> <li>• Installing the rack mount shelves</li> <li>• Installing the library modules in the rack</li> <li>• Cabling the multiple library stack and powering it up</li> </ul>

Refer to the appropriate product manuals for information about your tape drive and cartridges.

### **SCSI-2 Specification**

The SCSI-2 communications specification is the proposed American National Standard for information systems, dated March 9, 1990. Copies may be obtained from:

Global Engineering Documents  
15 Inverness Way, East  
Englewood, CO 80112  
(800) 854-7179 or (303) 397-2740



---

**Contacts**

Quantum company contacts are listed below.

**Quantum Corporate Headquarters**

To order documentation on the ATL M-Series libraries or other products contact:

Quantum Corporation  
P.O. Box 57100  
Irvine, CA 92619-7100  
(949) 856-7800  
(800) 284-5101

**Technical Publications**

To comment on existing documentation send e-mail to:

doc-comments@quantum.com

**Quantum Home Page**

Visit the Quantum home page at:

<http://www.quantum.com>

**Customer Support**

The Quantum Customer Support Department provides a 24-hour help desk that can be reached at:

North/South America: (949) 725-2100 or (800) 284-5101  
Asia/Pacific Rim: (International Code) + 61 7 3839 0988  
Europe/Middle East/Africa: (International Code) + 44 (0) 1256 848748

Send faxes for the Customer Support Department to:

North/South America: (949) 725-2176  
Asia/Pacific Rim: (International Code) + 61 7 3839 0955  
Europe/Middle East/Africa: (International Code) + 44 (0) 1256 848777

Send e-mail for the Customer Support Department to:

North/South America:            Go to <http://www.quantum.com/askaquestion> and enter your question and e-mail address

Asia/Pacific Rim:                [apachelp@quantum.com](mailto:apachelp@quantum.com)

Europe/Middle East/Africa:    [eurohelp@quantum.com](mailto:eurohelp@quantum.com)

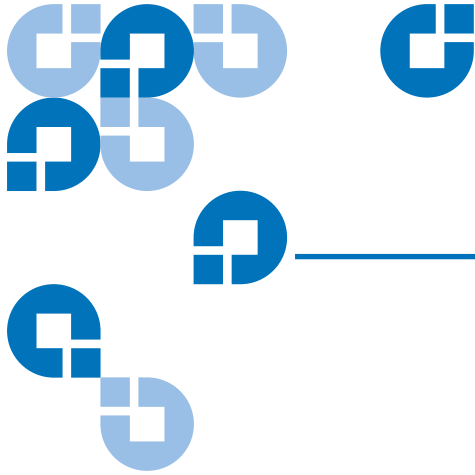

## Chapter 1 Overview

This chapter provides an overview of the ATL M-Series libraries and their features.

---

### Library Capacity

---

#### **ATL M1500 Library**

The ATL M1500 library can contain up to two tape drives and up to 21 DLT/SDLT cartridges or 25 LTO cartridges. The cartridges are stored in two independently removable cartridge magazines and one fixed cartridge slot.

---

#### **ATL M2500 Library**

The ATL M2500 library can contain:

- Up to five tape drives and up to 84 DLT/SDLT cartridges or 100 LTO cartridges
- Six tape drives and up to 73 DLT/SDLT cartridges or 87 LTO cartridges

The cartridges are stored in up to eight independently removable cartridge magazines and up to four fixed cartridge slots.

## Tape Drives

M-Series tape libraries are equipped with SCSI tape drives. One SCSI bus is provided for the library robotics and for each SCSI tape drive installed. These SCSI buses are SCSI-2 fast/wide (8/16 bit), Ultra SCSI, Ultra 2 SCSI, Ultra 3 SCSI, or Ultra 160 SCSI, depending on the drives installed.

LVD SCSI configurations have a maximum allowable bus length of 12 meters. To determine the cable length of the bus, measure the lengths of the SCSI cables connecting each device to that bus and add those lengths together. To that total length, add 12.25 inches (31.10 cm) for the internal SCSI cable length of each SCSI tape drive.

---

## Library Scalability

The ATL M1500 and ATL M2500 library modules can be used as stand-alone libraries, or can be combined with other ATL M1500 and ATL M2500 library modules and a StackLink mechanism in a standard 19-inch rack to form a larger library system (called a multiple library stack). The multiple library stack appears as a single large capacity library to the host.

The StackLink mechanism connects the library modules in the multiple library stack and transports cartridges from module to module. Each tape drive has access to all the tape cartridges in the stack.

Once the StackLink mechanism is installed in the rack, you can add library modules simply by sliding them into place and making the necessary electrical connections.

[Table 1](#) lists the capacities of all the sizes of multiple library stack you can create using ATL M1500 library modules. [Table 2](#) lists the capacities of all the sizes of multiple library stack you can create using ATL M2500 library modules. You can obtain different capacities by combining ATL M1500 and ATL M2500 library modules in a multiple library stack.

Table 1 Capacity,  
ATL M1500 Multiple  
Library Stack

# of ATL M1500 Library Modules	Max. # of Tape Drives	# of Cartridges*		Capacity (in TB)*											
		DLT/SDLT	LTO	DLT 8000		SDLT 220		SDLT 320		SDLT 600		HP LTO Gen 1		HP LTO Gen 2	
				Native	Compressed†	Native	Compressed†	Native	Compressed†	Native	Compressed†	Native	Compressed†	Native	Compressed†
1	2	21	25	0.8	1.7	2.3	4.6	3.4	6.7	6.3	12.6	2.5	5.0	5.0	10.0
2	4	42	50	1.7	3.4	4.6	9.2	6.7	13.4	12.6	25.2	5.0	10.0	10.0	20.0
3	6	63	75	2.5	5.0	6.9	13.9	10.1	20.2	18.9	37.8	7.5	15.0	15.0	30.0
4	8	84	100	3.4	6.7	9.2	18.5	13.4	26.9	25.2	50.4	10.0	20.0	20.0	40.0
5	10	105	125	4.2	8.4	11.6	23.1	16.8	33.6	31.5	63.0	12.5	25.0	25.0	50.0
6	12	126	150	5.0	10.1	13.9	27.7	20.2	40.3	37.8	75.6	15.0	30.0	30.0	60.0
7	14	147	175	5.9	11.8	16.2	32.3	23.5	47.0	44.1	88.2	17.5	35.0	35.0	70.0
8	16	168	200	6.7	13.4	18.5	37.0	26.9	53.8	50.4	100.8	20.0	40.0	40.0	80.0
9	18	189	225	7.6	15.1	20.8	41.6	30.2	60.5	56.7	113.4	22.5	45.0	45.0	90.0
10	20	210	250	8.4	16.8	23.1	46.2	33.6	67.2	63	126	25.0	50.0	50.0	100.0

\* The values in the # of Cartridges and Capacity columns assume that all the magazines and fixed cartridge slots are fully populated with data cartridges.

† Compressed values assume 2:1 compression ratios.

Table 2 Capacity,  
ATL M2500 Multiple  
Library Stack

# of ATL M2500 Library Modules	Max. # of Tape Drives	# of Cartridges*		Capacity (in TB)*											
		DLT/SDLT	LTO	DLT 8000		SDLT 220		SDLT 320		SDLT 600		HP LTO Gen 1		HP LTO Gen 2	
				Native	Compressed†	Native	Compressed†	Native	Compressed†	Native	Compressed†	Native	Compressed†	Native	Compressed†
1	0-5	84	100	3.4	6.7	9.2	18.5	13.4	26.9	25.2	50.4	10.0	20.0	20.0	40.0
1	6	73	87	2.9	5.8	8.0	16.1	11.7	23.4	21.9	43.8	8.7	17.4	17.4	34.8
2	0-10	168	200	6.7	13.4	18.5	37.0	26.9	53.8	50.4	100.8	20.0	40.0	40.0	80.0
2	11	157	187	6.3	12.6	17.3	34.5	25.1	50.2	47.1	94.2	18.7	37.4	37.4	74.8
2	12	146	174	5.8	11.7	16.1	32.1	23.4	46.7	43.8	87.6	17.4	34.8	34.8	69.6
3	0-15	252	300	10.1	20.2	27.7	55.4	40.3	80.6	75.6	151.2	30.0	60.0	60.0	120.0
3	16	241	287	9.6	19.3	26.5	53.0	38.6	77.1	72.3	144.6	28.7	57.4	57.4	114.8
3	17	230	274	9.2	18.4	25.3	50.6	36.8	73.6	69	138	27.4	54.8	54.8	109.6
3	18	219	261	8.8	17.5	24.1	48.2	35.0	70.1	65.7	131.4	26.1	52.2	52.2	104.4

\* The values in the **# of Cartridges** and **Capacity** columns assume that all the magazines and fixed cartridge slots are fully populated with data cartridges.

† Compressed values assume 2:1 compression ratios.

# Library Features

## Front Panel

[Figure 1](#) illustrates the features of the ATL M1500 library front panel. [Figure 2](#) illustrates the features of the ATL M2500 library front panel.

These features are described in [table 3](#).

Figure 1 ATL M1500  
Front Panel

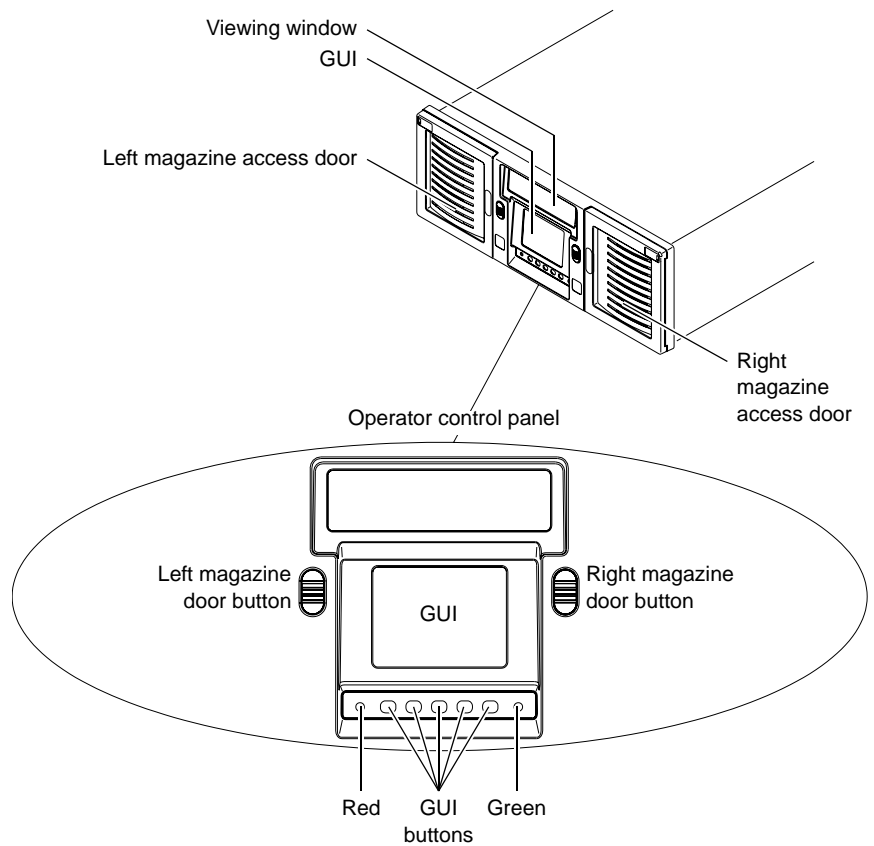

Figure 2 ATL M2500  
Front Panel

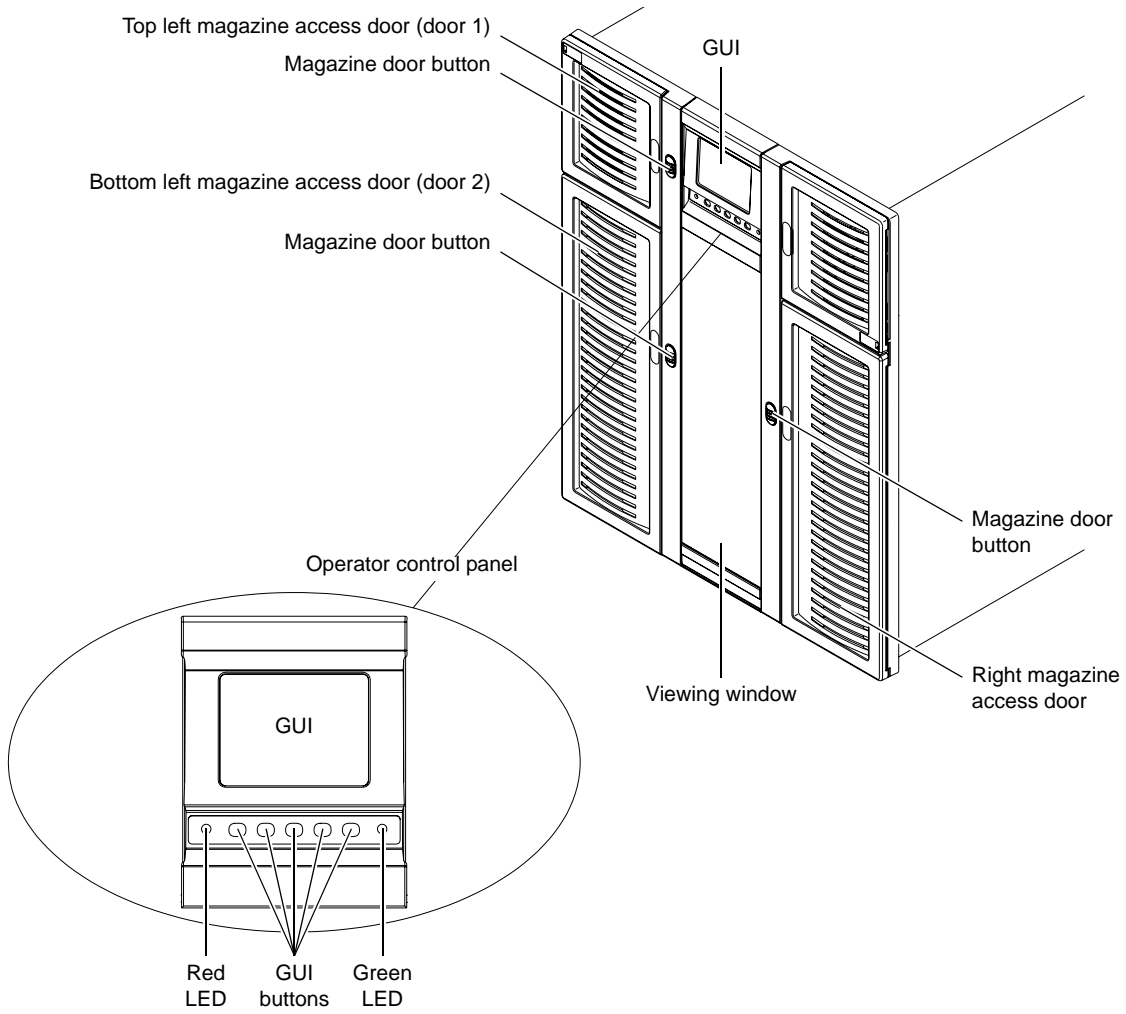



Table 3 Front Panel  
Features

Feature	Description
Operator control panel	<p>The operator control panel consists of the following elements:</p> <ul style="list-style-type: none"> <li data-bbox="396 430 1308 604">• Graphical user interface (GUI) The GUI displays library status information and allows you to access the library menus. These menus allow you to view or change the library settings, run demonstration programs, or run diagnostic tests. The GUI is discussed in detail in this book.</li> <li data-bbox="396 631 1286 760">• Five GUI buttons Use these buttons in combination with the GUI to scroll through screens and select options or commands. The functionality of these buttons changes depending on the currently displayed GUI screen.</li> <li data-bbox="396 788 1279 916">• Magazine door buttons Pressing these buttons opens the magazine doors, if the magazines have already been released using the <b>Mags</b> option on the GUI (see <a href="#">Removing the Magazines</a> on page 35).</li> <li data-bbox="396 944 1308 1343">• Light emitting diode (LED) indicators The operator control panel has two LED indicators: <ul style="list-style-type: none"> <li data-bbox="634 996 1308 1222">• The green LED lights when the library is fully operational and ready to accept host commands. It flashes while the library is transitioning from a READY state to a NOT READY state. The library will not be READY during power-on self-tests, when magazines are being released, or during access to certain menu items.</li> <li data-bbox="634 1239 1222 1274">• The red LED lights when there is a library error.</li> <li data-bbox="634 1291 1236 1343">• Both LEDs flash when there is a library fault that requires operator attention.</li> </ul> </li> </ul>
Magazine access doors	These doors protect the data cartridge magazines.
Viewing window	This window allows you to view the library robotics while the library is operating.

---

**Internal Layout**

[Figure 3](#) illustrates the internal layout of an ATL M1500 library. [Figure 4](#) illustrates the internal layout of an ATL M2500 library.

---

Figure 3 ATL M1500  
Internal Layout

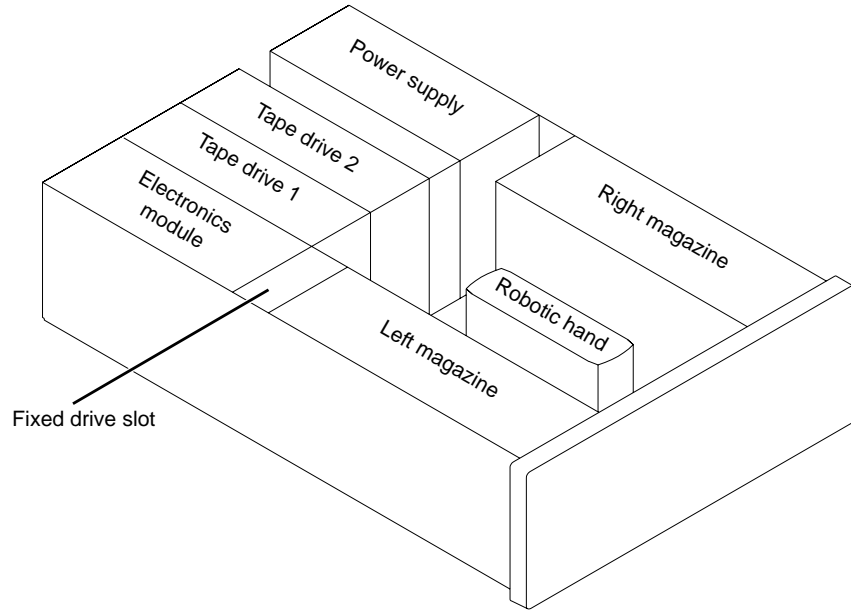
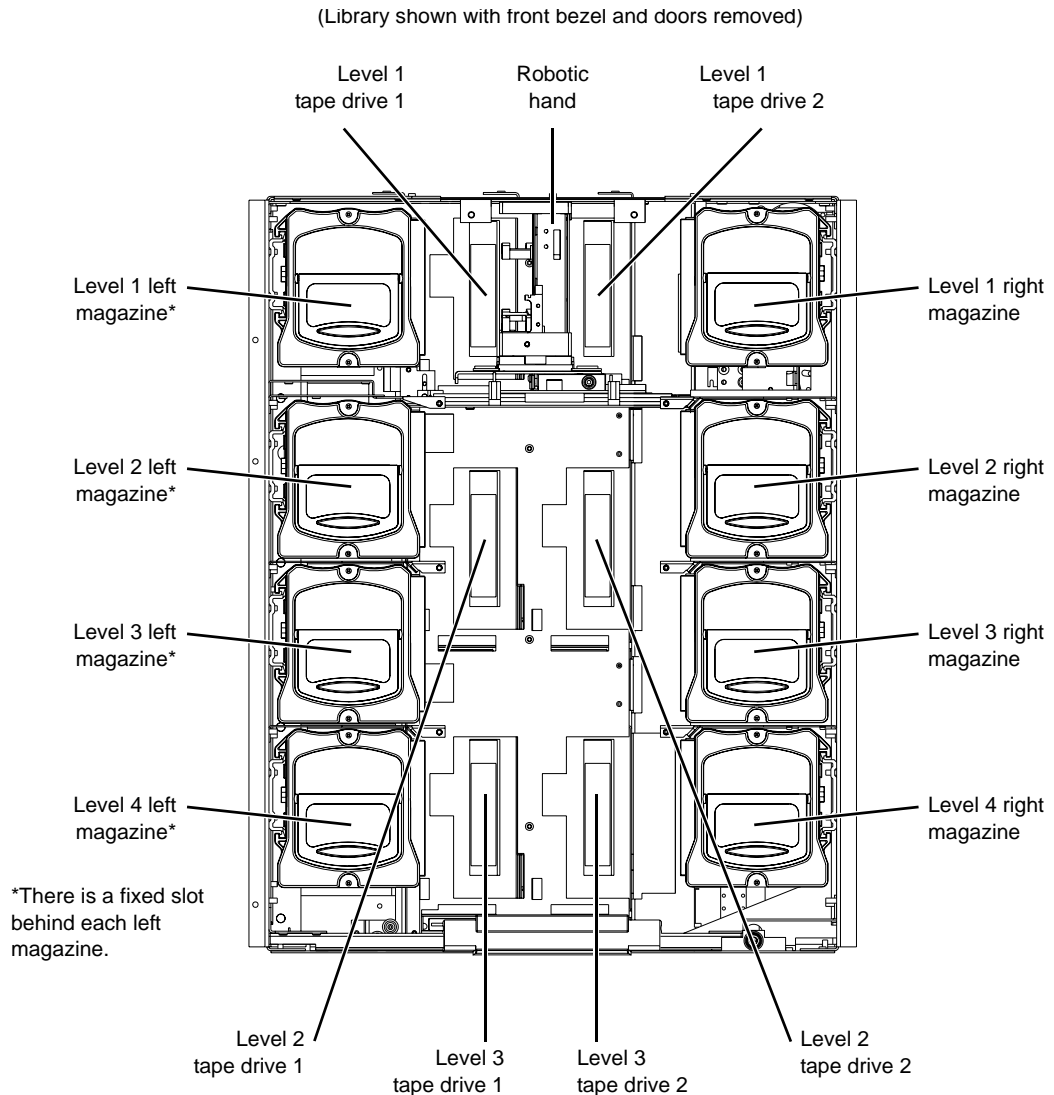

Figure 4 ATL M2500  
Internal Layout



Each cartridge magazine holds 10 DLT/SDLT cartridges or 12 LTO cartridges. The bins in the left magazines are numbered from 1 through 10 (or 12 in LTO libraries) from front to back. The bins in the right magazines are numbered from 1 through 10 (or 12 in LTO libraries) from back to front.

The ATL M1500 has one fixed cartridge slot behind the left magazine. The ATL M2500 has four fixed cartridge slots, one behind each left magazine. The fixed cartridge slots can be used as additional data cartridge bins, or can be used to hold cleaning tapes, which can be moved to a tape drive when cleaning is required.

A bar code reader is attached to the library's robotic hand. This bar code reader automatically identifies the cartridges in the library, if the cartridges are fitted with acceptable bar code labels.

---

## Back Panel

[Figure 5](#) illustrates the back panel of the ATL M1500 library. [Figure 6](#) illustrates the back panel of the ATL M2500 library.

---

Figure 5 ATL M1500  
Back Panel

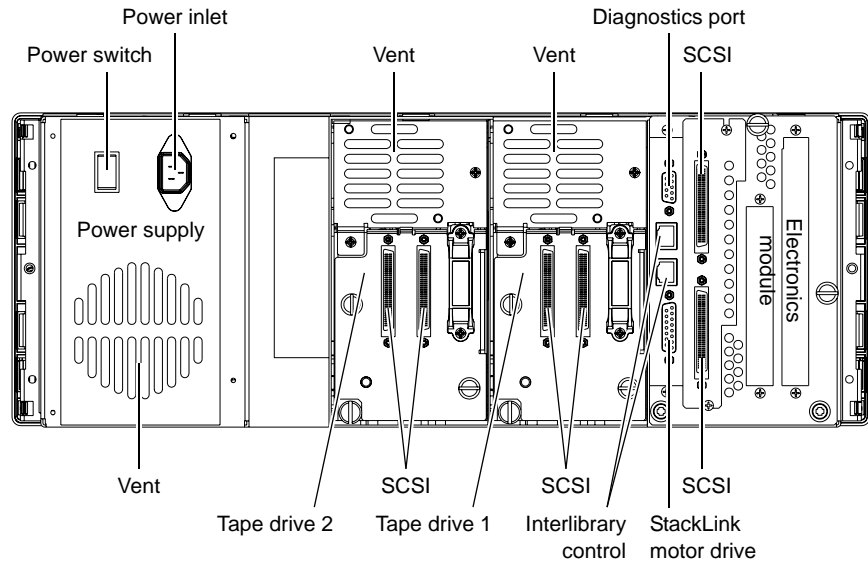
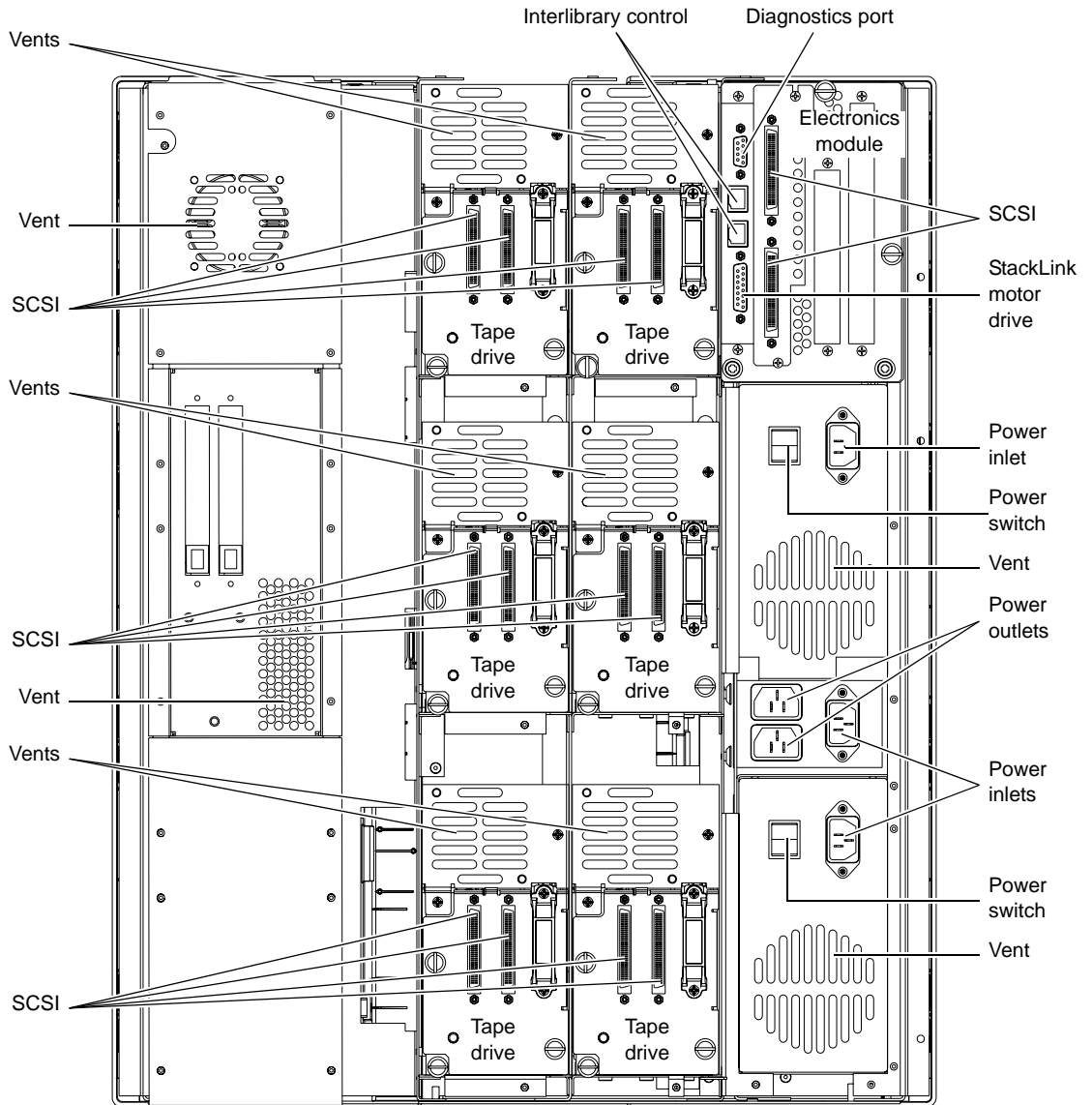
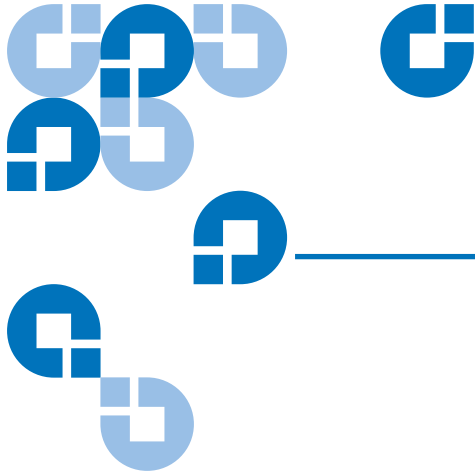

Figure 6 ATL M2500  
Back Panel







## Chapter 2

# Basic Operations

---

This chapter introduces the library GUI screens and explains how to use them to perform the following basic library operations:

- Viewing library information (see [Using the Quick View Menu Screen](#) on page 19)
- Moving tape cartridges within the library (see [Moving Tape Cartridges](#) on page 25)
- Using the mailbox (see [Using the Mailbox](#) on page 28)
- Removing the tape cartridge magazines (see [Removing the Magazines](#) on page 35)
- View library, drive and SCSI statistics (see [Viewing Statistics](#) on page 42)
- Viewing the configuration of the entire library and stack, if the library is part of a multiple library stack (see [Viewing the Stack Configuration](#) on page 47)

---

## Introduction

Before using the GUI to perform library functions, familiarize yourself with the:

- Main screen
- GUI buttons
- GUI icons

---

### Main Screen

The first screen the GUI displays after library initialization is the main screen. This screen displays library status and provides inventory information for the cartridge magazines, the fixed slot(s), the drives, and the robotic hand. It also provides access to the library menus. It updates in real time as cartridges move within the library.

The main screen appears somewhat different depending on whether the library is an:

- ATL M1500 stand-alone library
- ATL M1500 library in a multiple library stack
- ATL M2500 library

If the library is a stand-alone ATL M1500, the main screen appears as shown in [figure 7](#).



Figure 7 Sample Main Screen, Stand-alone ATL M1500

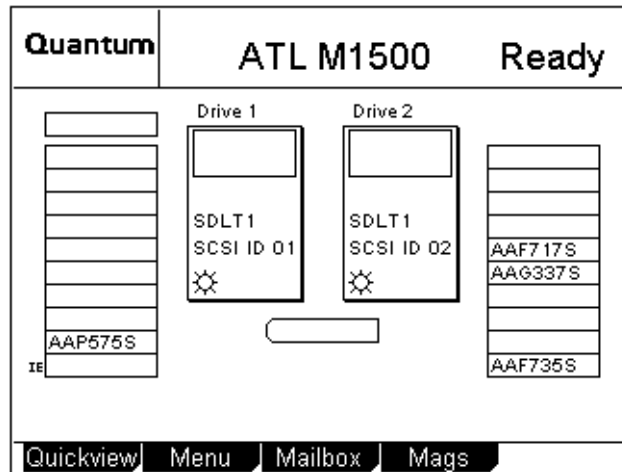

If the library is an ATL M1500 and is part of a multiple library stack, the main screen displays the level of the ATL M1500 module and provides an additional button, the **Stack** button (see [figure 8](#)).

**Note:** In a multiple library stack, each ATL M1500 library module is considered one “level” of the library. Each ATL M2500 library module is considered four levels of the library (see [figure 9](#)). Levels are numbered from top to bottom, starting with 1.

Figure 8 Sample Main Screen, ATL M1500 in a Multiple Library Stack

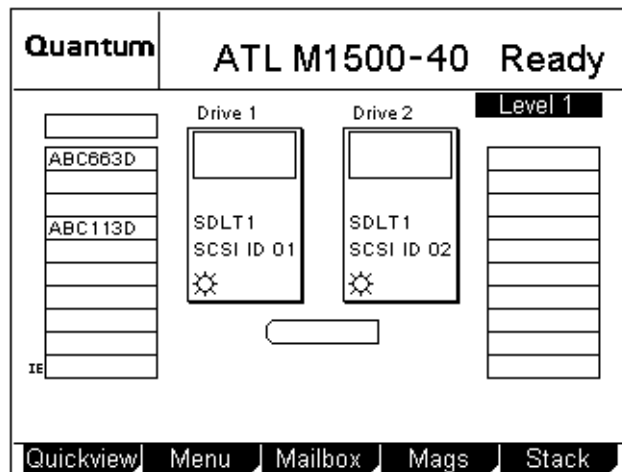

If the library is an ATL M2500, the first main screen provides a **Level** button and displays information about the top level of the ATL M2500 (see [figure 9](#) and [figure 10](#)). To view main screens for the other levels within the ATL M2500, press the **Level** button.

Figure 9 ATL M2500  
Library Levels

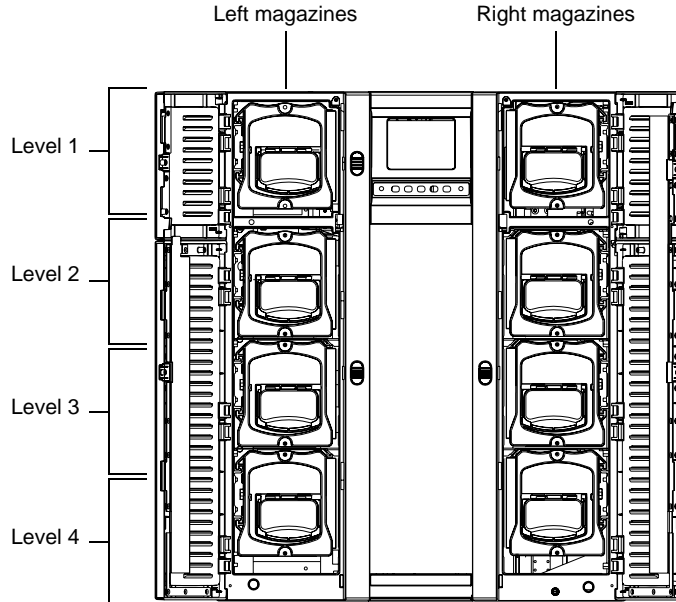
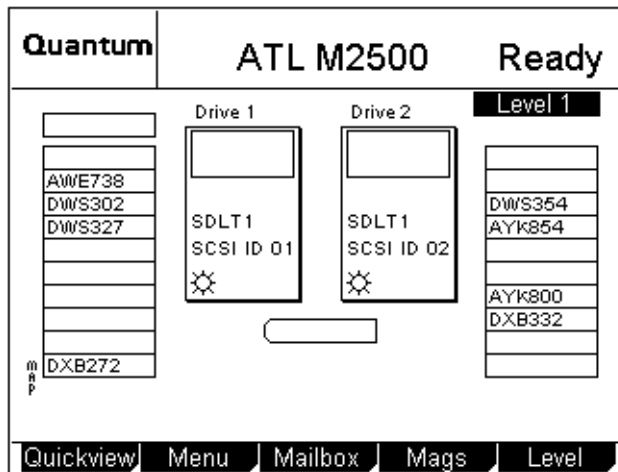

Figure 10 Sample  
Main Screen,  
ATL M2500



## GUI Buttons

At the bottom of each GUI screen are up to five button labels. These labels indicate the functions of the five push buttons below the GUI. To select a function, press the push button directly below the button label on the GUI screen (see [figure 11](#)).

Figure 11 Using the GUI Buttons

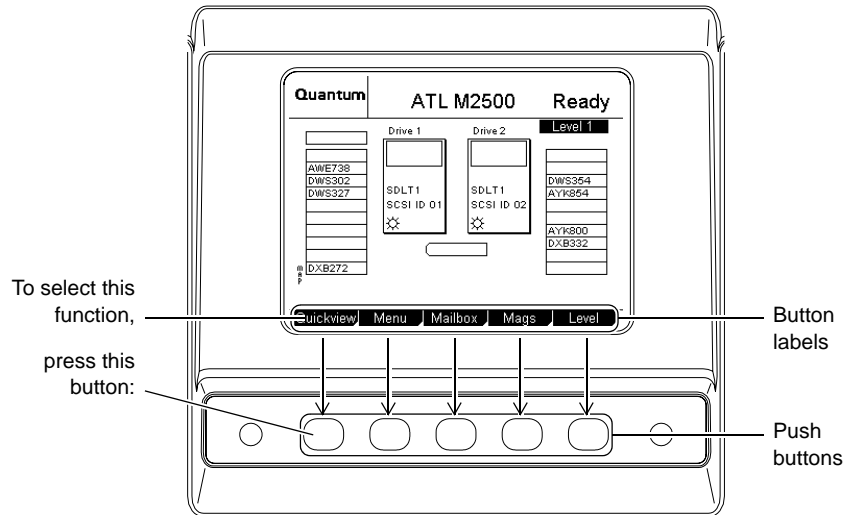











## GUI Icons

[Table 4](#) explains the meaning of each GUI icon.

Table 4 GUI Icons

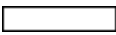
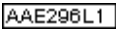
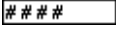
Icon	Meaning
	No tape present
	Tape loading
	Tape unloading
	Tape unloaded

Icon	Meaning
	Tape idle
	Tape rewinding
	Locating data
	Reading data
	Writing data
	Power on
	Drive fault
	Tape is write-protected
	Drive needs cleaning
	Slot empty
	Slot occupied
	Slot occupied - no label or bad bar code
	1 slot mailbox - NOT SCSI import/export element
	1 slot mailbox and SCSI import/export element

## Using the Quick View Menu Screen

The **Quick View Menu** screen allows you to view information about the library, drives, and inventory without placing the library in a NOT READY state.

**Note:** The **Quick View Menu** screen allows you to view the current library configuration only; you cannot make any changes to the configuration.

### Accessing the Quick View Menu Screen

To access the **Quick View Menu** screen, press **Quickview** on the main screen. The GUI displays the **Quick View Menu** screen (see [figure 12](#)).

Figure 12 Quick View Menu Screen

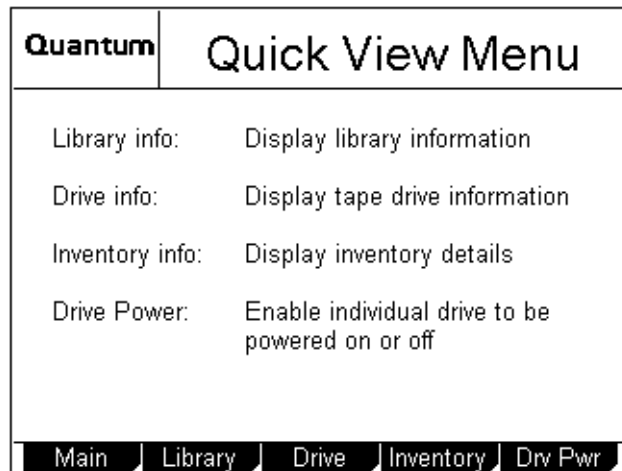

## Viewing Library Information

To view library information using the **Quick View Menu** screen:

- 1 Access the Quick View Menu screen (see [Accessing the Quick View Menu Screen](#)).
- 2 Press **Library**.

The GUI displays the **Library Information** screen (see [figure 13](#)).

Figure 13 Sample Library Information Screen

Quantum	Library Information
Model:	M2500
Code version:	Main code BCF_354
Boot version:	Boot code 3.00
Serial number:	0000LAP027
SCSI board type:	LVD
SCSI ID:	0
SCSI vendor ID:	ATL
SCSI product ID:	M2500
SCSI product rev:	BCF_354
<b>Back</b>	

The **Library Information** screen displays the following information about the library:

- Model
  - Code version
  - Boot version
  - Serial number
  - SCSI board type
  - SCSI ID
  - SCSI vendor ID
  - SCSI product ID
  - SCSI product revision
- 3 When you are finished viewing library information, press **Back** to return to the **Quick View Menu** screen.

## Viewing Tape Drive Information

To view tape drive information using the **Quick View Menu** screen:

- 1 Access the **Quick View Menu** screen (see [Accessing the Quick View Menu Screen](#)).
- 2 Press **Drive**.

The GUI displays the **Drive Information** screen (see [figure 14](#)).

Figure 14 Sample  
Drive Information  
Screen

Quantum	Drive Information
Drive 1:	<b>Level 1</b>
Drive type:	SDLT1
SCSI ID:	1
Serial number:	PKC02H0409
Code revision:	2323
Drive 2:	
Drive type:	SDLT1
SCSI ID:	2
Serial number:	PKB50H2377
Code revision:	2323
<b>Back</b>	<b>Level</b>

The **Drive Information** screen displays the following information about each drive installed in the library module:

- Drive type
- SCSI ID
- Serial number
- Code revision

**Note:** If the library is an ATL M2500, this screen displays a **Level** button. Pressing this button displays drive information for each library level within the ATL M2500.

- 3 To return to the **Drive Information** screen, press **Drv info**.
- 4 When you are finished viewing drive information in either the **Drive Information** screen or the **Drive Host I/O** screen, press **Back** to return to the **Quick View Menu** screen.

## Viewing Inventory Information

To view inventory information using the **Quick View Menu** screen:

- 1 Access the **Quick View Menu** screen (see [Accessing the Quick View Menu Screen](#)).
- 2 Press **Inventory**.

The GUI displays the **Inventory** screen (see [figure 15](#)).

Figure 15 Sample Inventory Screen

Quantum		Inventory	
Left	Fixed	Right	1
AWE738			
DWS302		DWS354	
DWS327	Drive 1	AYK854	
		AYK800	
	Drive 2	DXB332	
m h p DXB272			
Back		Level	

The **Inventory** screen provides a graphical representation of the library inventory.

**Note:** If the library is an ATL M1500 in a multiple library stack or an ATL M2500, this screen displays a **Level** button. Pressing this button displays inventory information for other library levels.

- 3 When you are finished viewing inventory information, press **Back** to return to the **Quick View Menu** screen.



### Turning Drive Power On or Off (Quick View Menu Screen)

The **Drive Power** option allows you to turn drive power on or off from the GUI. Use this option to turn off drive power when you are hot-swapping a tape drive.

**Note:** This option is available on both the **Quick View Menu** screen and the **Maintenance** screen. To access this option on the **Maintenance** screen, refer to [Turning Drive Power On or Off \(Maintenance Screen\)](#) on page 73.

### Turning Drive Power On or Off in an ATL M1500 Library

To turn drive power on or off in an ATL M1500 library:

- 1 Access the **Quick View Menu** screen (see [Accessing the Quick View Menu Screen](#) on page 19).
- 2 Press **Drv Pwr**.

The GUI displays the **Tape Drive Power** screen (see [figure 16](#)).

Figure 16 Sample Tape Drive Power Screen

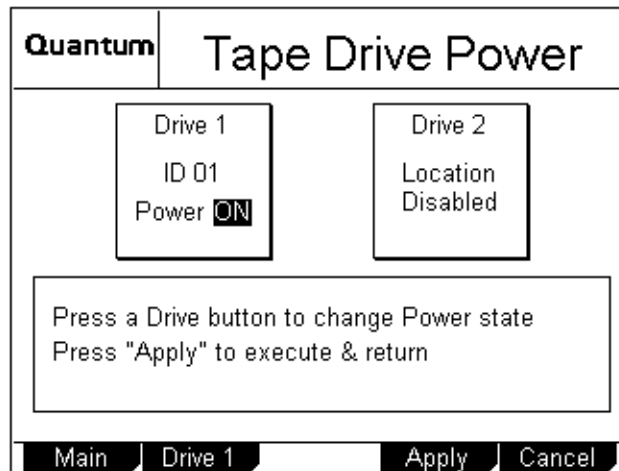

- 3 Press the button that corresponds to the drive you wish to power on or off: **Drive 1** or **Drive 2**.

The GUI displays the currently selected setting in the tape drive box at the top of the screen.

- 4 Press **Apply** to save the change and return to the **Quick View Menu** screen.

To return to the **Quick View Menu** screen without changing the power state of the drive, press **Cancel**.

### Turning Drive Power On or Off in an ATL M2500 Library

To turn drive power on or off in an ATL M2500 library:

- 1 Access the **Quick View Menu** screen (see [Accessing the Quick View Menu Screen](#) on page 19).
- 2 Press **Drv Pwr**.

The GUI displays the **Drive Power** screen (see [figure 17](#)).

Figure 17 Sample  
Drive Power Screen

Quantum	Drive Power	
Drive	Power	
Drive 1 Power	ON	
Drive 2 Power	ON	
Drive 4 Power	ON	

Main | Up | Down | Select | Back

- 3 Press the **Up** or **Down** buttons to highlight the drive you wish to power on or off.
- 4 Press **Select**.  
The drive power setting is highlighted.
- 5 Press the **Up** or **Down** buttons to change the current setting.

- 6 When the desired setting is displayed, press **Select**.  
To exit this screen without changing the drive power setting, press **Cancel**.
- 7 Press **Back** to save the change and return to the **Quick View Menu** screen.

---

## Moving Tape Cartridges

To move tape cartridges within the library:

- 1 On the main screen, press **Menu**.  
The GUI displays the **Menu** screen (see [figure 18](#)).

Figure 18 Menu  
Screen

Quantum	Menu
Move:	Move cartridges within library
Configuration:	Library, Drive and SCSI configuration
Service:	Library Statistics, Maintenance & Diagnostics
Demo:	Library demonstration programs

Main Move Config Service Demo

- 2 Press **Move**.  
The GUI displays the **Move Cartridge FROM** screen (see [figure 19](#)). A flashing arrow indicates the currently selected source element.

Figure 19 Sample  
Move Cartridge FROM  
Screen

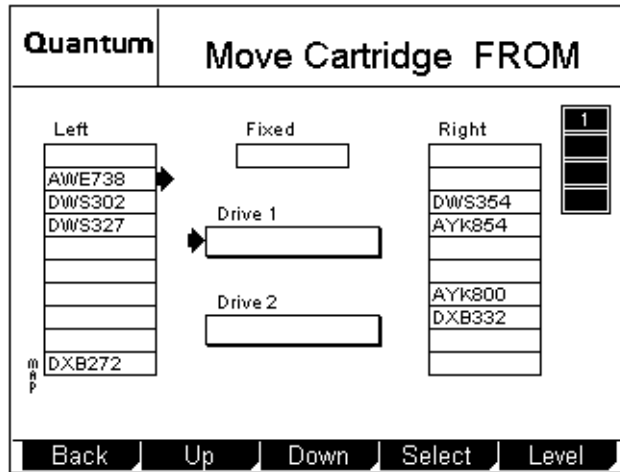

- 3 If the library is an ATL M1500 in a multiple library stack or an ATL M2500, press the **Level** button to select the level where the desired source element is located.
- 4 Press the **Up** and **Down** buttons to select the source element of the cartridge.
- 5 When the flashing arrow is next to the desired source element, press **Select**.

The GUI displays the **Move Cartridge TO** screen (see [figure 20](#)). A flashing arrow indicates the currently selected destination element.

Figure 20 Sample Move Cartridge TO Screen

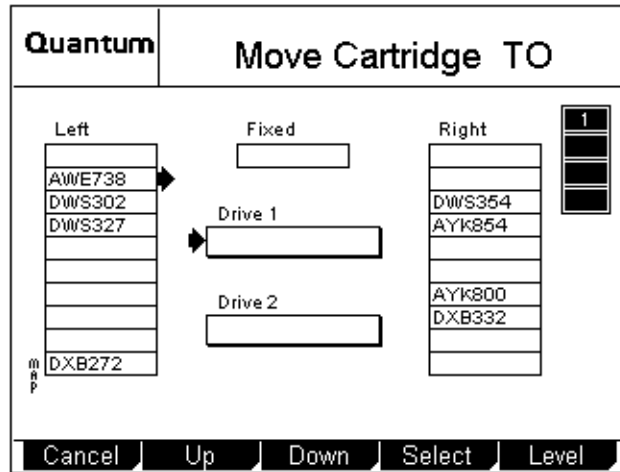

- 6 If the library is an ATL M1500 in a multiple library stack or an ATL M2500, press the **Level** button to select the level where the desired destination element is located.
- 7 Press the **Up** and **Down** buttons to select the destination element.
- 8 When the flashing arrow is next to the desired destination element, press **Select**.

The GUI displays the **Confirm Move Cartridge** screen (see [figure 21](#)).

Figure 21 Sample Confirm Move Cartridge Screen

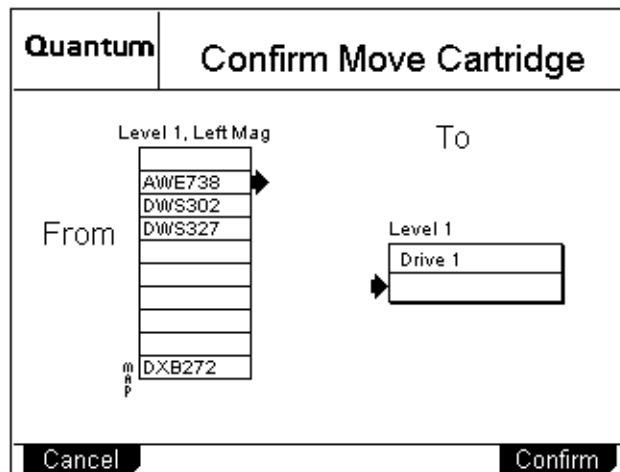

- 9 Verify that the GUI displays the correct source and destination elements, then press **Confirm**.

To cancel the cartridge move, press **Cancel**.

The GUI displays the message **Moving cartridge... Please wait**.

After the cartridge move is complete, the GUI displays the **Move Cartridge FROM** screen again.

- 10 Press **Back** to return to the **Menu** screen.
- 11 Press **Main** to return to the main screen.

---

## Using the Mailbox

Using the **Mailbox** screen, you can:

- View mailbox status
- Import and export cartridges
- Change the size of the mailbox by changing the setting of the **Import/Export** option

To access the **Mailbox** screen, press **Mailbox** on the main screen. The GUI displays the **Mailbox** screen (see [figure 22](#)).

Figure 22 Sample Mailbox Screen

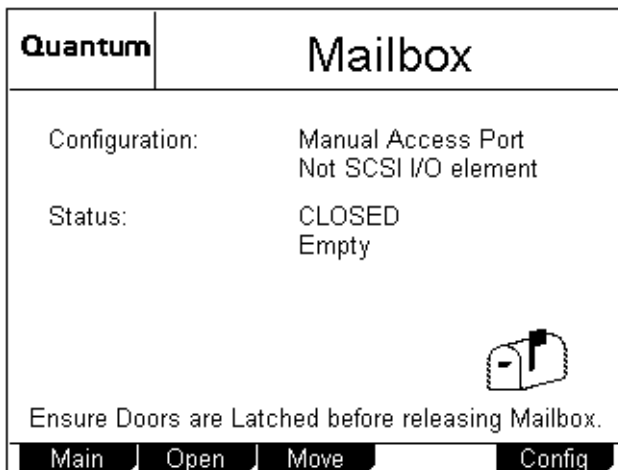

---

## Viewing Mailbox Status

The **Mailbox** screen displays the following information:

- The current setting of the **Import/Export** option (see [Changing the Import/Export Setting](#) on page 64 for more information about the available settings)
- Whether the mailbox is open or closed
- Whether the mailbox is occupied
- The bar code number of the cartridge, if the mailbox is occupied

**Note:** If the **Import/Export** option is set to None, the **Mailbox** screen does not display any “Status” or “Tape” information.

If the **Import/Export** option is set to 10-Slot (or 12-Slot for LTO), the **Mailbox** screen does not display any “Status: Occupied” or “Tape” information.

---

## Importing and Exporting Cartridges

The procedure for importing and exporting cartridges varies depending on the setting of the **Import/Export** option (see [Changing the Import/Export Setting](#) on page 64).

- To import and export cartridges when the **Import/Export** option is set to manual access port (MAP), see [Importing a Cartridge in MAP Mode](#) and [Exporting a Cartridge in MAP Mode](#).
- To import and export cartridges when the **Import/Export** option is set to 10-Slot (or 12-Slot in LTO libraries), see [Importing Cartridges in 10-Slot or 12-Slot Mode](#) and [Exporting Cartridges in 10-Slot or 12-Slot Mode](#).
- To import and export cartridges when the **Import/Export** option is set to 1-Slot, see [Importing a Cartridge in 1-Slot Mode](#) and [Exporting a Cartridge in 1-Slot Mode](#).

## Importing a Cartridge in MAP Mode

To import a cartridge in MAP mode:

- 1 On the main screen, press **Mailbox**.

The GUI displays the **Mailbox** screen (see [figure 22](#)).

- 2 Press **Open**.

The GUI displays the **Mailbox - OPEN** screen (see [figure 23](#)).

Figure 23 Mailbox -  
OPEN Screen

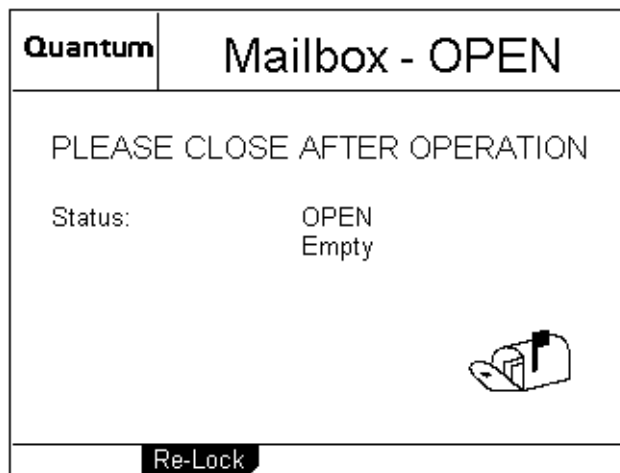

- 3 Press the button next to the top left magazine access door and open the door.
- 4 Pull the magazine forward until it stops.
- 5 Remove the data cartridge (if any) from the mailbox.
- 6 Insert the cartridge you wish to import into the mailbox.
- 7 Reinsert the magazine into the library.
- 8 Close the magazine access door.
- 9 On the **Mailbox - OPEN** screen, press **Re-Lock**.  
The library locks the magazine access door and inventories the mailbox.
- 10 Use the **Move** command on the **Mailbox** screen to move the imported cartridge to another data element.



- 11 If you removed a data cartridge from the mailbox, replace it:
  - a Repeat steps [1](#) through [4](#) to open the mailbox again.
  - b Reinsert the data cartridge you removed in [step 5](#) into the mailbox.
  - c Reinsert the magazine into the library.
  - d Close the magazine access door.
  - e On the **Mailbox** screen, press **Re-Lock**.  
The magazine access door locks.

### Exporting a Cartridge in MAP Mode

To export a cartridge in MAP mode:

- 1 If there is currently a data cartridge in the mailbox, remove it:
  - a On the main screen, press **Mailbox**.  
The GUI displays the **Mailbox** screen (see [figure 22](#)).
  - b Press **Open**.  
The GUI displays the **Mailbox - OPEN** screen (see [figure 23](#)).
  - c Press the button next to the top left magazine access door and open the door.
  - d Pull the magazine forward until it stops.
  - e Remove the data cartridge from the mailbox.
  - f Reinsert the magazine into the library.
  - g Close the magazine access door.
  - h On the **Mailbox - OPEN** screen, press **Re-Lock**.  
The library locks the magazine access door and inventories the mailbox.
- 2 Use the **Move** command on the **Mailbox** screen to move the cartridge you wish to export to the mailbox.
- 3 Repeat steps [1a](#) through [1d](#) to open the mailbox again.
- 4 Remove the exported cartridge from the mailbox.
- 5 Reinsert the data cartridge you removed in [step 1e](#) (if any) into the mailbox.

6 Reinsert the magazine into the library.

7 Close the magazine access door.

8 On the **Mailbox - OPEN** screen, press **Re-Lock**.

The library locks the magazine access door and inventories the mailbox.

### Importing Cartridges in 10-Slot or 12-Slot Mode

To import cartridges in 10-slot or 12-slot mode:

1 On the main screen, press **Mailbox**.

The GUI displays the **Mailbox** screen (see [figure 22](#)).

2 Press **Open**.

The GUI displays the **Mailbox - OPEN** screen (see [figure 23](#)).

3 Press the button next to the top left magazine access door and open the door.

4 Pull the magazine out of the library.

5 Insert the cartridges you wish to import into the magazine.

6 Reinsert the magazine into the library.

7 Close the magazine access door.

8 On the **Mailbox - OPEN** screen, press **Re-Lock**.

The library locks the magazine access door and the cartridges are moved under control of the host software to the desired locations.

### Exporting Cartridges in 10-Slot or 12-Slot Mode

To export cartridges in 10-slot or 12-slot mode:

1 Use the backup software to export cartridges to the top left magazine.

2 On the main screen, press **Mailbox**.

The GUI displays the **Mailbox** screen (see [figure 22](#)).

3 Press **Open**.

The GUI displays the **Mailbox - OPEN** screen (see [figure 23](#)).

- 4 Press the button next to the top left magazine access door and open the door.
- 5 Pull the magazine out of the library.
- 6 Remove the cartridges from the magazine.
- 7 Reinsert the magazine into the library.
- 8 Close the magazine access door.
- 9 On the **Mailbox - OPEN** screen, press **Re-Lock**.  
The library locks the magazine access door.

### Importing a Cartridge in 1-Slot Mode

To import a cartridge in 1-slot mode:

- 1 On the main screen, press **Mailbox**.  
The GUI displays the **Mailbox** screen (see [figure 22](#)).
- 2 Press **Open**.  
The GUI displays the **Mailbox - OPEN** screen (see [figure 23](#)).
- 3 Press the button next to the top left magazine access door and open the door.
- 4 Pull the magazine forward until it stops.
- 5 Insert the cartridge you wish to import into the mailbox.
- 6 Reinsert the magazine into the library.
- 7 Close the magazine access door.
- 8 On the **Mailbox - OPEN** screen, press **Re-Lock**.  
The library locks the magazine access door and the cartridge is moved under control of the host software to the desired location.

## Exporting a Cartridge in 1-Slot Mode

To export a cartridge in 1-slot mode:

- 1 Use the backup software to export a cartridge to the first slot of the top left magazine.
- 2 On the main screen, press **Mailbox**.  
The GUI displays the **Mailbox** screen (see [figure 22](#)).
- 3 Press **Open**.  
The GUI displays the **Mailbox - OPEN** screen (see [figure 23](#)).
- 4 Press the button next to the top left magazine access door and open the door.
- 5 Pull the magazine forward until it stops.
- 6 Remove the exported cartridge from the magazine.
- 7 Reinsert the magazine into the library.
- 8 Close the magazine access door.
- 9 On the **Mailbox - OPEN** screen, press **Re-Lock**.  
The library locks the magazine access door.

---

## Configuring the Mailbox

By default, the **Import/Export** option is set to MAP. To change this setting:

- 1 On the main screen, press **Mailbox**.  
The GUI displays the **Mailbox** screen (see [figure 22](#)).
- 2 On the **Mailbox** screen, press **Config**.  
The GUI displays the **Configuration** screen, with the **Import/Export** option highlighted.
- 3 Use the **Up** and **Down** buttons to select the desired **Import/Export** setting. The available settings are None, 1-Slot, 10-Slot (or 12-Slot in LTO libraries), and MAP.

**Note:** The default setting is MAP. For more information about these settings, see [Changing the Import/Export Setting](#) on page 64.

- 4 Press **Select**.
- 5 Press **Main** to return to the main screen.

**Note:** You must reboot the library before this setting will take effect.

---

## Removing the Magazines

To remove a magazine from an ATL M1500 library, see [Removing a Magazine from an ATL M1500](#).

To remove a magazine from an ATL M2500 library, see [Removing a Magazine from an ATL M2500](#).

---

### Removing a Magazine from an ATL M1500

The method for removing the magazines differs depending on whether the ATL M1500 library is powered up or down:

- To remove a magazine from the ATL M1500 library when it is powered up, see [Removing a Magazine When the ATL M1500 Library Is Powered Up](#).
- To remove a magazine from the ATL M1500 library when it is powered down, see [Removing a Magazine When the ATL M1500 Library Is Powered Down](#).

### Removing a Magazine When the ATL M1500 Library Is Powered Up

The magazines are locked in place during normal library operation. To remove one of these magazines, you must first release the magazine using the GUI.

To remove the left or right magazine when the ATL M1500 library is powered up:

- 1 On the main screen, press **Mags**.

The GUI displays the **Release Magazines** screen (see [figure 24](#)).

Figure 24 Sample  
Release Magazines  
Screen

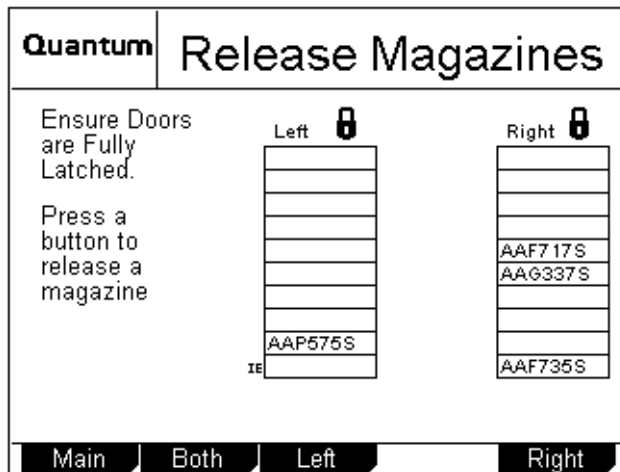

- 2 Press the button corresponding to the magazine you want to release:
  - To release both magazines, press **Both**.
  - To release the left magazine, press **Left**.
  - To release the right magazine, press **Right**.

The GUI indicates that the magazine or magazines have been released.

- 3 Press the button next to the desired magazine access door and open the door.
- 4 Grasp the handle at the front of the magazine and pull it forward and out of the library.
- 5 When you are finished adding or removing cartridges from the magazine, replace it in the library and close the magazine door.
- 6 On the **Release Magazines** screen, press **Re-Lock**.

The library locks the magazine access doors and inventories the magazines. When the inventory is complete, the GUI displays the main screen.

## Removing a Magazine When the ATL M1500 Library Is Powered Down

To remove a magazine when the library is powered down:

- 1 Look through the viewing window and verify that all cartridges are fully seated either in a magazine slot or in the robotic hand.

**Caution:** You can damage the library severely if you try to remove a magazine when one of the data cartridges is not fully seated.

- 2 Press the button next to the magazine access door.

The magazine access door opens.

- 3 To remove the left magazine:

- a Using a slender object such as a pen, press and hold the magazine release button (see [figure 25](#)).
- b Grasp the handle at the front of the left magazine and slide it forward and out of the library.

Figure 25 Magazine Release Button

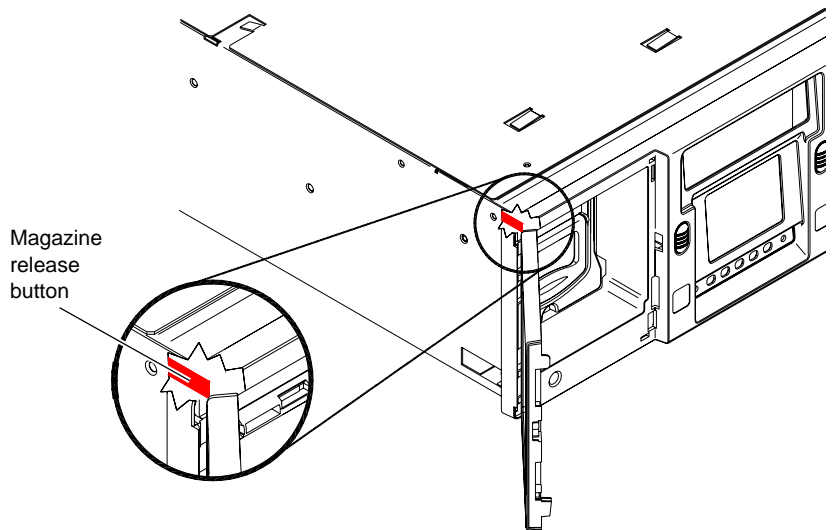

- 4 To remove the right magazine, grasp the handle at the front of the magazine and slide it forward and out of the library.

## Removing a Magazine from an ATL M2500

The method for removing the magazines differs depending on whether the ATL M2500 library is powered up or down:

- To remove a magazine from the ATL M2500 library when it is powered up, see [Removing a Magazine When the ATL M2500 Library Is Powered Up](#).
- To remove a magazine from the ATL M2500 library when it is powered down, see [Removing a Magazine When the ATL M2500 Library Is Powered Down](#).

### Removing a Magazine When the ATL M2500 Library Is Powered Up

The magazines are locked in place during normal library operation. To remove one of these magazines, you must first release the magazine using the GUI.

To remove a magazine when the library is powered up:

- 1 On the main screen, press **Mags**.

The GUI displays the **Release Magazines** screen (see [figure 26](#)).

Figure 26 Release Magazines Screen

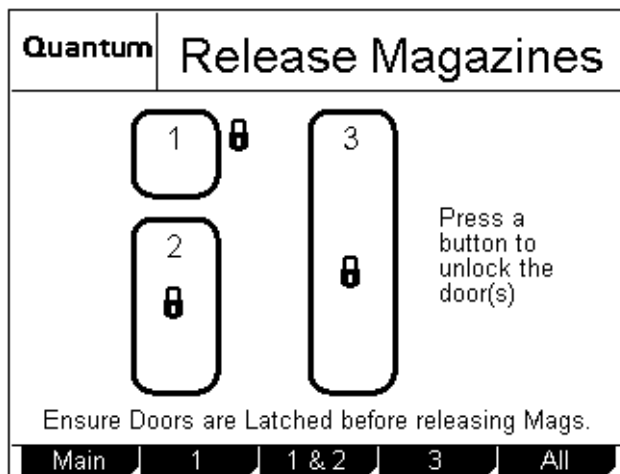



- 2 Press the button corresponding to the magazine access door you want to open:
  - To release the top left magazine access door, press **1**.
  - To release both left magazine access doors, press **1 & 2**.
  - To release the right magazine access door, press **3**.
  - To release all the magazine access doors, press **All**.
- 3 Press the button next to the desired magazine access door and open the door.

**Note:** If you are opening the bottom left magazine access door, open the top left magazine access door first.

- 4 Grasp the handle at the front of the desired magazine and pull it forward and out of the library.
- 5 When you are finished adding or removing cartridges from the magazine, replace it in the library and close the magazine access door.
- 6 On the **Release Magazines** screen, press **Re-Lock**.

The library locks the magazine access doors and inventories the magazines. When the inventory is complete, the GUI displays the main screen.

### Removing a Magazine When the ATL M2500 Library Is Powered Down

To remove a magazine when the library is powered down:

- 1 Look through the viewing window and verify that all cartridges are fully seated either in a magazine slot or in the robotic hand.

**Caution:** You can damage the library severely if you try to remove a magazine when one of the data cartridges is not fully seated.

- 2 To remove the level 1 left magazine:
  - a Press the button next to the top left magazine access door and open the door.
  - b Grasp the handle at the front of the level 1 left magazine and pull it forward until it stops.

**Note:** If the **Import/Export** option is set to 1-Slot or MAP, you will only be able to pull out the top left magazine far enough to access the first magazine slot.

If the Import/Export option is set to None or 10-Slot (12-Slot for LTO libraries) you will be able to pull the top left magazine all the way out of the library.

- c If the magazine stops after the first slot, perform steps [2d](#) through [2h](#) to remove it.
- d Press the button next to the bottom left magazine access door and open the door.
- e Remove the level 2 left magazine (see [figure 27](#)).

Figure 27 Removing the Level 2 Left Magazine

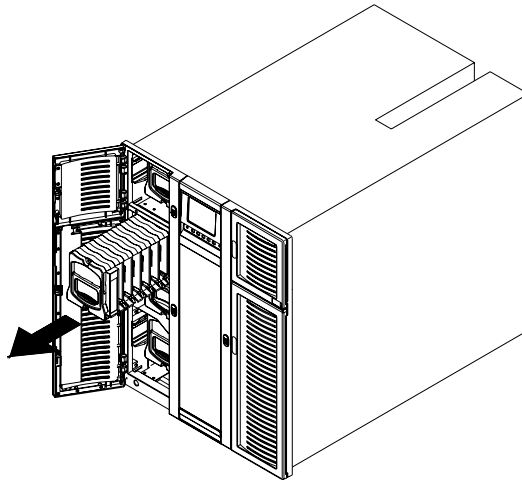

- f Reach into the library underneath the level 1 left magazine and pull down on the release latch (see [figure 28](#)).

Figure 28 Release Latch

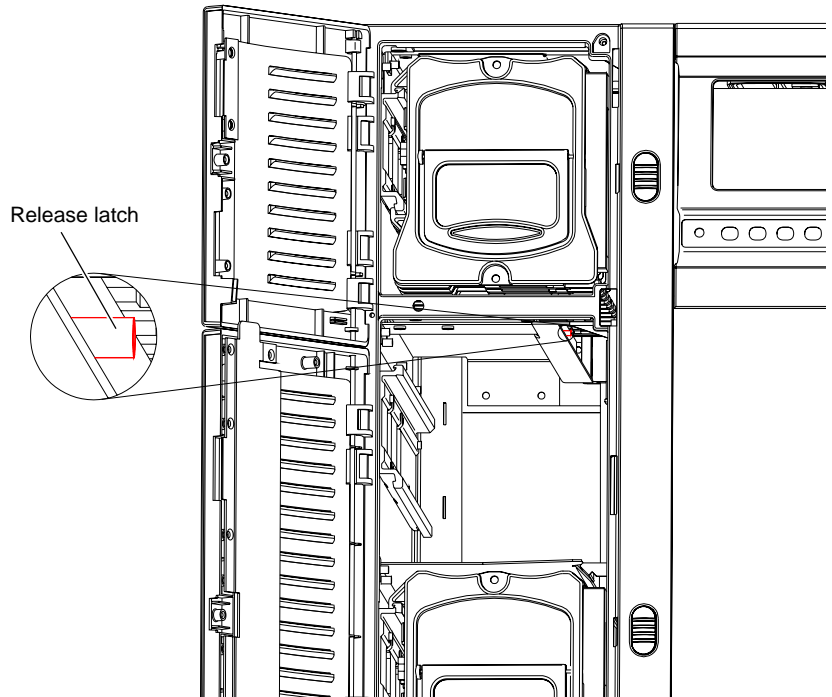

- g** While holding the release latch, pull the level 1 left magazine forward and out of the library (see [figure 29](#)).

Figure 29 Removing the Level 1 Left Magazine

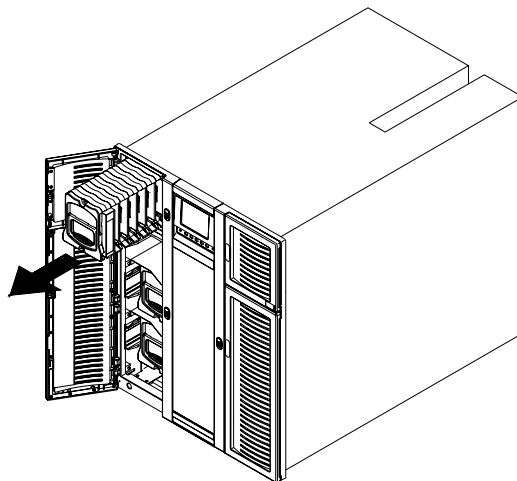

- h** Reinsert the level 2 left magazine into the library and close the bottom left magazine access door.
- 3** To remove any other magazine:
  - a** Press the button next to the desired magazine access door.

**Note:** If you are opening the bottom left magazine access door, open the top left magazine access door first.

The magazine access door opens.

- b** Grasp the handle at the front of the desired magazine and slide it forward and out of the library.

---

## Viewing Statistics

This section explains how to view library, drive, and SCSI statistics using the **Statistics Menu** screen.

---

### Accessing the Statistics Menu Screen

To access the **Statistics Menu** screen:

- 1** On the main screen, press **Menu**.

The GUI displays the **Menu** screen.

- 2** Press **Service**.

The GUI displays the **Service Menu** screen (see [figure 30](#)).

Figure 30 Service Menu Screen

Quantum	Service Menu
Stats:	Library and Drive statistics
Maintenance:	Cleaning, Drive Power etc.
Diagnostics:	Robotic movement tests, Friction tests etc.
Drive:	Drive service options
<span>Stats</span> <span>Maint</span> <span>Diag</span> <span>Drive</span> <span>Back</span>	

**3** Press **Stats**.

The GUI displays the **Statistics Menu** screen (see [figure 31](#)).

Figure 31 Statistics Menu Screen

Quantum	Statistics Menu
Library Stats:	Slot stows & fetches, mags stats, barcode stats etc.
Drive Stats:	Drive stows & fetches
SCSI History:	SCSI bus commands
<span>Main</span> <span>Library</span> <span>Drive</span> <span>SCSI</span> <span>Back</span>	

## Viewing Library Statistics

To view library statistics:

- 1 Access the **Statistics Menu** screen (see [Accessing the Statistics Menu Screen](#)).
- 2 On the **Statistics Menu** screen, press **Library**.

The GUI displays the **Library Statistics** screen (see [figure 32](#)).

Figure 32 Sample Library Statistics Screen

Quantum	Library Statistics
Power On Hours	92
Slot Fetches Good	8981
Slot Fetches Bad	13
Slot Stows Good	8978
Slot Stows Bad	22
Barcode Retries	0
Magazine Inserts	17
X Axis Distance	2138913
Y Axis Distance	4546689

↓

Main Up Down Back

This screen lists the following library statistics:

- Power On Hours
- Slot Fetches Good
- Slot Fetches Bad
- Slot Stows Good
- Slot Stows Bad
- Barcode Retries
- Magazine Inserts
- X Axis Distance
- Y Axis Distance
- Z Axis Distance
- Theta Distance

- Picker Distance
  - Elevator Distance
- 3 Press the **Up** and **Down** buttons to scroll through the list.
  - 4 When you have finished viewing the library statistics, press **Back** to return to the **Statistics Menu** screen, or press **Main** to return to the main screen.

---

### Viewing Drive Statistics

To view drive statistics:

- 1 Access the **Statistics Menu** screen (see [Accessing the Statistics Menu Screen](#)).
- 2 On the **Statistics Menu** screen, press **Drive**.

The GUI displays the **Drive Statistics** screen (see [figure 33](#)).

---

Figure 33 Sample Drive Statistics Screen

Quantum	Drive Statistics	
	Drive Fetches Good	458
	Drive Fetches Bad	0
	Drive Stows Good	458
	Drive Stows Bad	110

Main Back

This screen lists the following drive statistics:

- Drive Fetches Good
- Drive Fetches Bad
- Drive Stows Good
- Drive Stows Bad

- 3 When you have finished viewing the drive statistics, press **Back** to return to the **Statistics Menu** screen, or press **Main** to return to the main screen.

## Viewing the SCSI History

To view a list of the SCSI commands run on the library:

- 1 Access the **Statistics Menu** screen (see [Accessing the Statistics Menu Screen](#)).
- 2 On the **Statistics Menu** screen, press **SCSI**.

The GUI displays the **SCSI History** screen (see [figure 34](#)).

Figure 34 Sample SCSI History Screen

Quantum	SCSI History	
5-Mar-2002 8:45	Move Medium	OK
5-Mar-2002 8:46	Move Medium	OK
5-Mar-2002 8:46	Move Medium	OK
5-Mar-2002 8:46	Move Medium	OK
5-Mar-2002 8:46	Move Medium	OK
5-Mar-2002 8:46	Move Medium	OK
5-Mar-2002 8:46	Move Medium	OK
5-Mar-2002 8:46	Move Medium	OK
5-Mar-2002 8:47	Move Medium	OK
5-Mar-2002 8:48	Log Sense	05-24-00
5-Mar-2002 8:48	Request Sense	OK
5-Mar-2002 8:52	Inquiry	OK

Main Up Down Back

This screen lists SCSI commands by date and time.

- 3 Press the **Up** and **Down** buttons to scroll through the list.
- 4 When you have finished viewing the SCSI history, press **Back** to return to the **Statistics Menu** screen, or press **Main** to return to the main screen.



## Viewing the Stack Configuration

If the library module is part of a multiple library stack, you can view the configuration of the entire stack using the **Stack Configuration** screen.

To access the **Stack Configuration** screen:

- On an ATL M1500 library, press **Stack** on the main screen.
- On an ATL M2500 library, press **Level** on the main screen until the **Stack** button appears at the lower right corner of the screen. Press **Stack**.

The GUI displays the **Stack Configuration** screen (see [figure 35](#)).

Figure 35 Sample Stack Configuration Screen

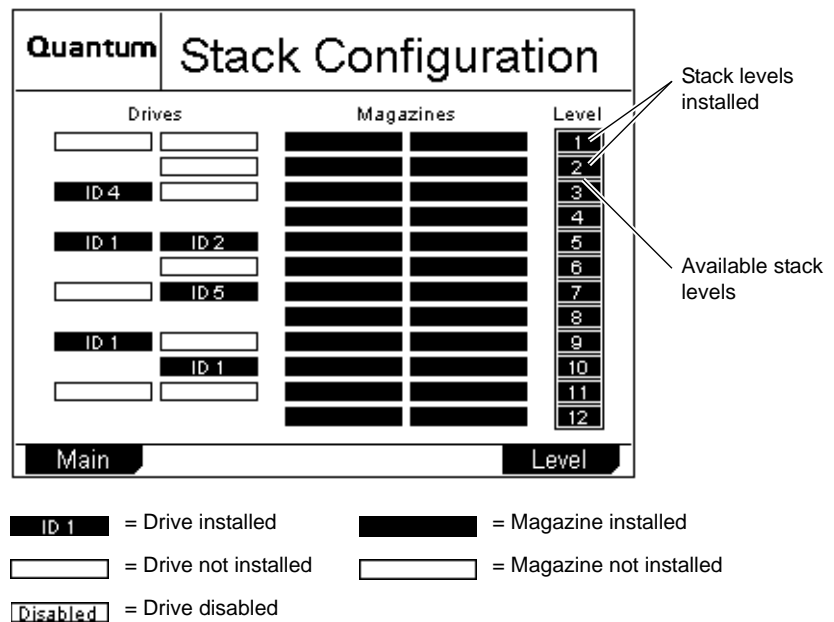

This screen displays the:

- Maximum size of the library (this depends on the height of the StackLink installed)
- Number of library modules installed in the stack
- Number, location, and bus IDs of the tape drives installed
- Number and location of the tape cartridge magazines installed

When you are finished viewing the **Stack Configuration** screen, press **Main** to return to the main screen.

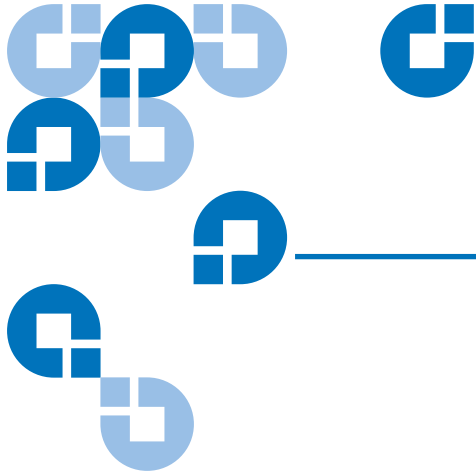

## Chapter 3

# Changing the Library Configuration

---

This chapter explains how to change the library configuration using the GUI **Configuration** screen.

---

## Accessing the Configuration Screen

To access the **Configuration** screen:

- 1 On the main screen, press **Menu**.

The GUI displays the **Menu** screen (see [figure 36](#)).

Figure 36 Menu  
Screen

Quantum	Menu
Move:	Move cartridges within library
Configuration:	Library, Drive and SCSI configuration
Service:	Library Statistics, Maintenance & Diagnostics
Demo:	Library demonstration programs

Main Move Config Service Demo

2 Press **Config**.

The GUI displays the **Configuration** screen (see [figure 37](#)).

Figure 37  
Configuration Screen

Quantum	Configuration
<u>Parameter</u>	<u>Setting</u>
Library ID	0
Drive 1 Interface	Fibre
Drive 2 Interface	SCSI
Drive 1 ID	Soft
Drive 2 ID	2
Terminator Power	Enabled
Emulation	ATL 1500
Sync Negotiation	Enabled

Main Up Down Select Back

---

## Setting the Library ID

By default the library SCSI ID is set to 0. To change the library SCSI ID setting:

- 1 Access the **Configuration** screen (see [Accessing the Configuration Screen](#)).
- 2 Press the **Up** or **Down** buttons until **Library ID** is highlighted.
- 3 Press **Select**.
- 4 Use the **Up** or **Down** buttons to select the desired SCSI ID. Available settings are 0 through 15.
- 5 Press **Select**.

To return to the **Configuration** screen without changing the option setting, press **Cancel**.

- 6 Press **Main** to return to the main screen.

**Note:** You must reboot the library before this setting will take effect.

---

## Changing a Tape Drive ID

By default, the ATL M1500 tape drive SCSI IDs are set as follows:

- Drive 1 ID = 1
- Drive 2 ID = 2

By default, the ATL M2500 tape drive SCSI IDs are set as follows:

- Drive 1 ID = 1
- Drive 2 ID = 2
- Drive 3 ID = 3
- Drive 4 ID = 4

- Drive 5 ID = 15
- Drive 6 ID = 14

[Figure 38](#) illustrates the drive numbering scheme for the ATL M2500.

Figure 38 ATL M2500  
Drive Numbering

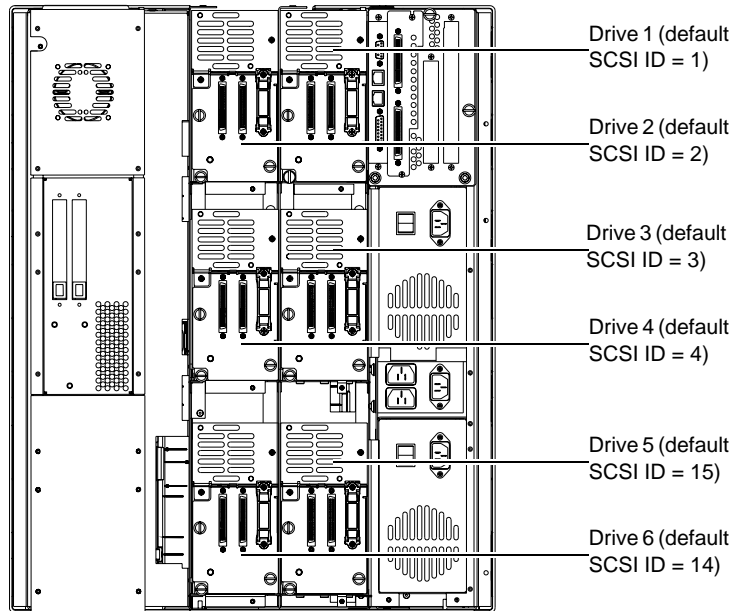

To change a tape drive SCSI ID:

- 1 Access the **Configuration** screen (see [Accessing the Configuration Screen](#)).
- 2 Press the **Up** or **Down** buttons until the desired drive ID (for example, **Drive 1 ID**) is highlighted.
- 3 Press **Select**.
- 4 Use the **Up** or **Down** buttons to select the desired drive ID. Available settings are 0 through 15 and Disabled.

**Caution:** Set the drive SCSI ID to Disabled only if the drive is not installed in the library.

- 5 Press **Select**.

To return to the **Configuration** screen without changing the option setting, press **Cancel**.

- 6 If desired, repeat steps [2](#) through [5](#) to set the ID for another tape drive.
- 7 Press **Main** to return to the main screen.

**Note:** You must reboot the library before this setting will take effect.

---

## Changing the Terminator Power Setting

The **Terminator Power** option controls whether the library robotics provide terminator power.

To enable or disable robotics terminator power:

- 1 Access the **Configuration** screen (see [Accessing the Configuration Screen](#)).
- 2 Press the **Up** or **Down** buttons until **Terminator Power** is highlighted.
- 3 Press **Select**.
- 4 Use the **Up** or **Down** buttons to select the desired **Terminator Power** setting. Available settings are Enabled and Disabled.

**Note:** The default setting is Enabled.

- 5 Press **Select**.

To return to the **Configuration** screen without changing the option setting, press **Cancel**.

- 6 Press **Main** to return to the main screen.

**Note:** You must reboot the library before this setting will take effect.

---

## Changing the Emulation Setting

The **Emulation** option allows you to set the library to act as either a Quantum ATL library or an M4 Data library.

To set the emulation:

- 1 Access the **Configuration** screen (see [Accessing the Configuration Screen](#) on page 49).
- 2 Press the **Up** or **Down** buttons until **Emulation** is highlighted.
- 3 Press **Select**.
- 4 Use the **Up** or **Down** buttons to select the desired **Emulation** setting. The available settings are ATL M2500, ATL 1500, and M4 Data.

**Note:** The default setting for the ATL M1500 is M4 Data; the default setting for the ATL M2500 is ATL M2500.

- 5 Press **Select**.

To return to the **Configuration** screen without changing the option setting, press **Cancel**.

- 6 Press **Main** to return to the main screen.

**Note:** You must reboot the library before this setting will take effect.



---

## Changing the Storage Slot Count Setting

The **Storage Slot Count** option controls how many storage elements are reported to the SCSI host.

**Note:** When changing this option setting in a multiple library stack, you must use the GUI on the SCSI master (the library module connected to the SCSI host) in order for the change to take effect.

To change the **Storage Slot Count** setting:

- 1 Access the **Configuration** screen (see [Accessing the Configuration Screen](#) on page 49).
- 2 Press the **Up** or **Down** buttons until **Storage Slot Count** is highlighted.
- 3 Press **Select**.
- 4 Use the **Up** or **Down** buttons to select the desired **Storage Slot Count** setting. The available settings are:
  - Default (all storage elements detected by the library are reported to the SCSI host)
  - Any value from 1 through the number of storage elements in the library (this number varies depending on the library, the tape drive type, and the setting of the **Import/Export** and **Auto Clean** options)

**Note:** The default setting is Default.

- 5 Press **Select**.

To return to the **Configuration** screen without changing the option setting, press **Cancel**.

- 6 Press **Main** to return to the main screen.

**Note:** You must reboot the library before this setting will take effect.

---

## Changing the Sync Negotiation Setting

The **Sync Negotiation** option controls whether the library robotics negotiates synchronous data transfer mode. Normally, this negotiation is performed by the host.

**Note:** This option does not enable or disable synchronous data transfers; it only controls the ability of the library to negotiate for such transfers.

To enable or disable **Sync Negotiation**:

- 1 Access the **Configuration** screen (see [Accessing the Configuration Screen](#) on page 49).
- 2 Press the **Up** or **Down** buttons until **Sync Negotiation** is highlighted.
- 3 Press **Select**.
- 4 Use the **Up** or **Down** buttons to select the desired **Sync Negotiation** setting. The available settings are Enabled and Disabled.

**Note:** The default setting is Enabled.

- 5 Press **Select**.

To return to the **Configuration** screen without changing the option setting, press **Cancel**.

- 6 Press **Main** to return to the main screen.

---

## Changing the Wide Negotiation Setting

The **Wide Negotiation** option controls whether the library robotics negotiates wide data transfer mode. Normally, this negotiation is performed by the host.

**Note:** This option does not enable or disable wide data transfers; it only controls the ability of the library to negotiate for such transfers.

To enable or disable **Wide Negotiation**:

- 1 Access the **Configuration** screen (see [Accessing the Configuration Screen](#) on page 49).
- 2 Press the **Up** or **Down** buttons until **Wide Negotiation** is highlighted.
- 3 Press **Select**.
- 4 Use the **Up** or **Down** buttons to select the desired **Wide Negotiation** setting. The available settings are Enabled and Disabled.

**Note:** The default setting is Enabled.

- 5 Press **Select**.

To return to the **Configuration** screen without changing the option setting, press **Cancel**.

- 6 Press **Main** to return to the main screen.

---

## Changing the Serialization Setting

The **Serialization** option controls how the library returns the tape drive serial number when a Read Element Status is requested.

When **Serialization** is set to On, the tape drive serial number is returned in a format compatible with Quantum ATL Prism products. When **Serialization** is set to Off, the tape drive serial number is returned in a vendor unique format. This setting is only valid when **Emulation** is set to ATL M2500 or ATL 1500 (see [Changing the Emulation Setting](#) on page 54).

To enable or disable drive serialization:

- 1 Access the **Configuration** screen (see [Accessing the Configuration Screen](#) on page 49).
- 2 Press the **Up** or **Down** buttons until **Serialization** is highlighted.
- 3 Press **Select**.
- 4 Use the **Up** or **Down** buttons to select the desired **Serialization** setting. The available settings are Enabled and Disabled.

<p><b>Note:</b> The default setting is Disabled.</p>
--

- 5 Press **Select**.  
To return to the **Configuration** screen without changing the option setting, press **Cancel**.
- 6 Press **Main** to return to the main screen.

---

## Changing the Short Labels Setting

The **Short Labels** option controls how many bar code label characters are returned when the host issues a Read Element Status command. When **Short Labels** is set to:

- Off, all of the bar code label characters are returned
- On, only the first six characters of the bar code label are returned

To enable or disable **Short Labels**:

- 1 Access the **Configuration** screen (see [Accessing the Configuration Screen](#) on page 49).
- 2 Press the **Up** or **Down** buttons until **Short Labels** is highlighted.
- 3 Press **Select**.
- 4 Use the **Up** or **Down** buttons to select the desired **Short Labels** setting. The available settings are Enabled and Disabled.

**Note:** The default setting is Disabled.

- 5 Press **Select**.
- 6 To return to the **Configuration** screen without changing the option setting, press **Cancel**.
- 7 Press **Main** to return to the main screen.

---

## Changing the Illumination Setting

The **Illumination** option allows you to turn the interior illumination of the library on or off. This illumination allows you to view the robotics easily through the viewing window.

To enable or disable **Illumination**:

- 1 Access the **Configuration** screen (see [Accessing the Configuration Screen](#) on page 49).
- 2 Press the **Up** or **Down** buttons until **Illumination** is highlighted.
- 3 Press **Select**.
- 4 Use the **Up** or **Down** buttons to select the desired **Illumination** setting. The available settings are Enabled and Disabled.

**Note:** The default setting is Enabled.

**5** Press **Select**.

To return to the **Configuration** screen without changing the option setting, press **Cancel**.

**6** Press **Main** to return to the main screen.

---

## Changing the Off-Line Time Setting

When you access the **Menu** screen using the GUI, the library becomes NOT READY and will not respond to any SCSI commands issued. If you leave the library unattended in menu mode, the library goes back to a READY state after a pre-set time-out, controlled by the **Off-Line Time** option. You can set this time-out to any value from 1 to 99 minutes, or turn it off.

To set the **Off-Line Time**:

- 1** Access the **Configuration** screen (see [Accessing the Configuration Screen](#) on page 49).
- 2** Press the **Up** or **Down** buttons until **Off-Line Time** is highlighted.
- 3** Press **Select**.
- 4** Use the **Up** or **Down** buttons to select the desired **Off-Line Time** setting. The available settings are 1 through 99 and Disabled.

<p><b>Note:</b> The default setting is Disabled.</p>
--

**5** Press **Select**.

To return to the **Configuration** screen without changing the option setting, press **Cancel**.

**6** Press **Main** to return to the main screen.

---

## Changing the Barcode Scanner Setting

The **Barcode Scanner** option controls whether the bar code scanner is enabled or disabled. When the scanner is enabled, the library attempts to detect a bar code on all tape cartridge labels. If the correct bar code labels are not used, or if some cartridges are not labeled, scanning time may be greatly increased. Therefore, it is recommended that you disable the **Barcode Scanner** option if you do not intend to use compatible bar code labels.

To enable or disable the **Barcode Scanner** option:

- 1 Access the **Configuration** screen (see [Accessing the Configuration Screen](#) on page 49).
- 2 Press the **Up** or **Down** buttons until **Barcode Scanner** is highlighted.
- 3 Press **Select**.
- 4 Use the **Up** or **Down** buttons to select the desired **Barcode Scanner** setting. The available settings are Enabled and Disabled.

**Note:** The default setting is Enabled.

- 5 Press **Select**.

To return to the **Configuration** screen without changing the option setting, press **Cancel**.

- 6 Press **Main** to return to the main screen.

**Note:** You must reboot the library before this setting will take effect.

---

## Changing the Baud Rate Setting

The **Baud Rate** option controls the baud rate setting of the serial diagnostics port. You can set the baud rate to any standard rate between 1200 baud and 38400 baud.

To set the **Baud Rate**:

- 1 Access the **Configuration** screen (see [Accessing the Configuration Screen](#) on page 49).
- 2 Press the **Up** or **Down** buttons until **Baud Rate** is highlighted.
- 3 Press **Select**.
- 4 Use the **Up** or **Down** buttons to select the desired **Baud Rate** setting. The available settings are 38400, 19200, 9600, 4800, 2400, and 1200.
- 5 Press **Select**.  
To return to the **Configuration** screen without changing the option setting, press **Cancel**.
- 6 Press **Main** to return to the main screen.

---

## Setting the Time

To set the time:

- 1 Access the **Configuration** screen (see [Accessing the Configuration Screen](#) on page 49).
- 2 Press the **Up** or **Down** buttons until **Time** is highlighted.
- 3 Press **Select**.  
The hour setting is highlighted.
- 4 Use the **Up** or **Down** buttons to select the correct hour setting.
- 5 Press **Select**.  
The minute setting is highlighted.
- 6 Use the **Up** or **Down** buttons to select the correct minute setting.



- 7 Press **Select**.  
The seconds setting is highlighted.
- 8 Use the **Up** or **Down** buttons to select the correct seconds setting.
- 9 Press **Select**.
- 10 Press **Main** to return to the main screen.

---

## Setting the Date

To set the date:

- 1 Access the **Configuration** screen (see [Accessing the Configuration Screen](#) on page 49).
- 2 Press the **Up** or **Down** buttons until **Date** is highlighted.
- 3 Press **Select**.  
The day setting is highlighted.
- 4 Use the **Up** or **Down** buttons to select the correct day of the month.
- 5 Press **Select**.  
The month setting is highlighted.
- 6 Use the **Up** or **Down** buttons to select the correct month.
- 7 Press **Select**.  
The year setting is highlighted.
- 8 Use the **Up** or **Down** buttons to select the correct year.
- 9 Press **Select**.
- 10 Press **Main** to return to the main screen.

---

## Changing the Import/Export Setting

The **Import/Export** option controls whether the host recognizes the slots of the top left magazine as import/export elements or as storage elements:

- Import/export elements are used to move cartridges in and out of the library under host control. Because these elements are used exclusively for importing and exporting cartridges, they are left empty during normal library operation, reducing the storage capacity of the library.
- Storage elements are used to store data cartridges. Using storage elements to import and export cartridges can be risky since these operations are not controlled by the host.

[Table 5](#) describes each of the possible settings for the **Import/Export** option.

---

Table 5 Import/Export Settings

<b>Import/Export Setting</b>	<b>Description</b>
MAP	<p>When manual access port (MAP) is selected, you can use the first slot in the top left magazine to import and export cartridges from the library. The host views the MAP as a storage element; therefore, after using the MAP to import a cartridge, you must replace the data cartridge that was originally stored there.</p> <p>For information about importing and exporting cartridges when MAP is selected, see <a href="#">Importing a Cartridge in MAP Mode</a> on page 30 and <a href="#">Exporting a Cartridge in MAP Mode</a> on page 31.</p>

<b>Import/Export Setting</b>	<b>Description</b>
10-Slot (or 12-Slot in LTO libraries)	<p>When this setting is selected, all slots in the top left magazine are configured as import/export elements. They cannot be used for storage.</p> <p>For more information about importing and exporting cartridges when 10-Slot (or 12-Slot) is selected, see <a href="#">Importing Cartridges in 10-Slot or 12-Slot Mode</a> on page 32 and <a href="#">Exporting Cartridges in 10-Slot or 12-Slot Mode</a> on page 32.</p>
1-Slot	<p>When this setting is selected, the first slot in the top left magazine is configured as an import/export element. It cannot be used for storage.</p> <p>For more information about importing and exporting cartridges when 1-Slot is selected, see <a href="#">Importing a Cartridge in 1-Slot Mode</a> on page 33 and <a href="#">Exporting a Cartridge in 1-Slot Mode</a> on page 34.</p>
None	<p>When this setting is selected, the top left magazine is used as a 10- or 12-cartridge storage element and behaves in exactly the same way as the other magazines.</p>

To select the **Import/Export** setting:

**Caution:** Changing this setting may cause the host(s) to fail to recognize the library. If you change this setting, be aware that you will have to reconfigure your backup software for the new library configuration.

- 1 Access the **Configuration** screen (see [Accessing the Configuration Screen](#) on page 49).
- 2 Press the **Up** or **Down** buttons until **Import/Export** is highlighted.
- 3 Press **Select**.

- 4 Use the **Up** or **Down** buttons to select the desired **Import/Export** setting. The available settings are None, 1-Slot, 10-Slot (or 12-Slot in LTO libraries), and MAP.

**Note:** The default setting is MAP.

- 5 Press **Select**.

To return to the **Configuration** screen without changing the option setting, press **Cancel**.

- 6 Press **Main** to return to the main screen.

**Note:** You must reboot the library before this setting will take effect.

---

## Changing the Auto-Clean Setting

To enable or disable **Auto-Clean**:

- 1 Access the **Configuration** screen (see [Accessing the Configuration Screen](#) on page 49).
- 2 Press the **Up** or **Down** buttons until **Auto-Clean** is highlighted.
- 3 Press **Select**.
- 4 Use the **Up** or **Down** buttons to select the desired **Auto-Clean** setting. The available settings are Enabled or Disabled.

**Note:** The default setting is Disabled.

- 5 Press **Select**.

To return to the **Configuration** screen without changing the option setting, press **Cancel**.

- 6 Press **Main** to return to the main screen.

**Note:** You must reboot the library before this setting will take effect.

---

## Changing the Ignore Host Lock Setting

The **Ignore Host Lock** option controls whether the library can release the mailbox when the host has issued a SCSI command to lock the media:

- Enabling this option allows you to release the mailbox even when the host has issued a SCSI command to lock the media.
- Disabling this option causes the library to display an error message when you try to release the mailbox when the host has locked the media.

To change the **Ignore Host Lock** setting:

- 1 Access the **Configuration** screen (see [Accessing the Configuration Screen](#) on page 49).
- 2 Press the **Up** or **Down** buttons until **Ignore Host Lock** is highlighted.
- 3 Press **Select**.
- 4 Use the **Up** or **Down** buttons to select the desired **Ignore Host Lock** setting. The available settings are Enabled or Disabled.

**Note:** The default setting is Disabled.

- 5 Press **Select**.

To return to the **Configuration** screen without changing the option setting, press **Cancel**.

- 6 Press **Main** to return to the main screen.

**Note:** You must reboot the library before this setting will take effect.

---

## Changing the Auto-Import Option

The **Auto-Import** option controls how cartridges are moved from the import/export slots of the mailbox to the magazine slots:

- Enabling this option causes the library to move any cartridges in the import/export slots to the first (lowest element address) free magazine slots automatically. The move is performed automatically (without need for host commands) at both power-up and whenever the import/export magazine is inserted.
- Disabling this option removes the above capability; the host software must issue SCSI commands to move cartridges from the import/export slots to the required magazine slots.

To change the **Auto-Import** setting:

- 1 Access the **Configuration** screen (see [Accessing the Configuration Screen](#) on page 49).
- 2 Press the **Up** or **Down** buttons until **Auto-Import** is highlighted.
- 3 Press **Select**.
- 4 Use the **Up** or **Down** buttons to select the desired **Auto-Import** setting. The available settings are Enabled or Disabled.

**Note:** The default setting is Disabled.

- 5 Press **Select**.

To return to the **Configuration** screen without changing the option setting, press **Cancel**.

- 6 Press **Main** to return to the main screen.

**Note:** You must reboot the library before this setting will take effect.

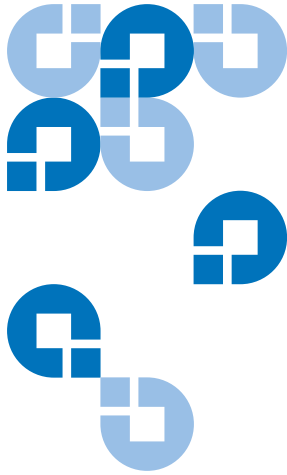

# Performing Maintenance Operations

---

This chapter explains how to perform library maintenance operations using the **Maintenance** screen.

---

## Accessing the Maintenance Screen

To access the **Maintenance** screen:

- 1 On the main screen, press **Menu**.

The GUI displays the **Menu** screen.

- 2 Press **Service**.

The GUI displays the **Service Menu** screen (see [figure 39](#)).

Figure 39 Service Menu Screen

Quantum	Service Menu
Stats:	Library and Drive statistics
Maintenance:	Cleaning, Drive Power etc.
Diagnostics:	Robotic movement tests, Friction tests etc.
Drive:	Drive service options
Stats   Maint   Diag   Drive   Back	

**3** Press **Maint**.

The GUI displays the **Maintenance** screen (see [figure 40](#)).

Figure 40 Maintenance Screen

Quantum	Maintenance
Clean	Execute an Auto-cleaning cycle
Drv Pwr	Enables individual Tape Drives to be powered on and off
Contrast	Adjust screen contrast
↻ Robotics	Re-initialize robotics
Clean   Drv Pwr   Contrast   Robotics   Back	



## Cleaning a Tape Drive

To clean a tape drive:

- 1 Access the **Maintenance** screen (see [Accessing the Maintenance Screen](#)).
- 2 Press **Clean**.

The GUI displays the **Select Cleaning Cartridge** screen (see [figure 41](#)). A flashing arrow indicates the currently selected source element.

Figure 41 Sample Select Cleaning Cartridge Screen

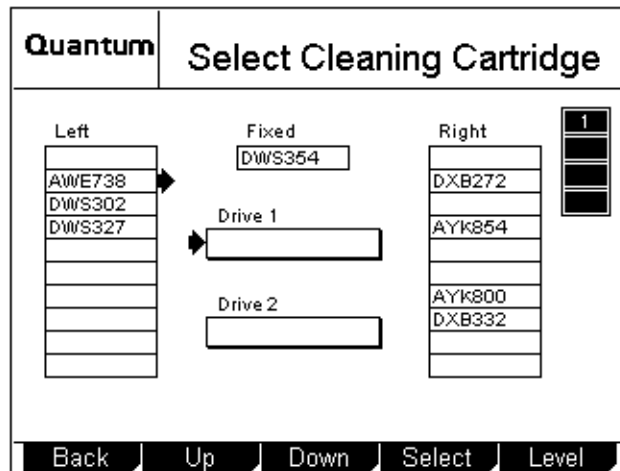

- 3 If the library is an ATL M1500 in a multiple library stack or an ATL M2500, press the **Level** button to select the level where the cleaning cartridge is located.
- 4 Press the **Up** and **Down** buttons to select the source element that contains the cleaning cartridge.
- 5 When the flashing arrow is next to the source element that contains the cleaning cartridge, press **Select**.

The GUI displays the **Select Tape Drive** screen (see [figure 42](#)). A flashing arrow indicates the currently selected drive.

Figure 42 Sample  
Select Tape Drive  
Screen

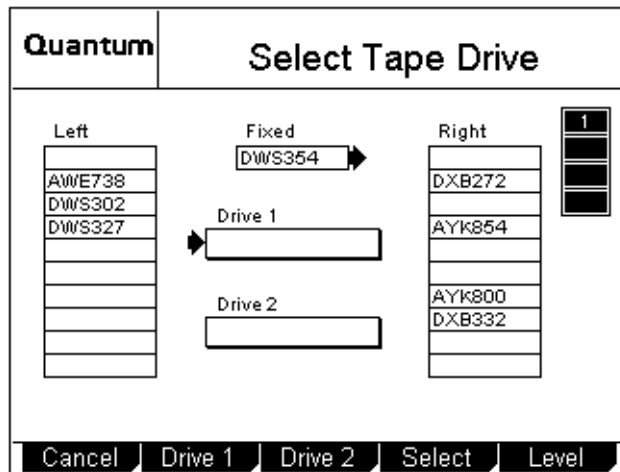

- 6 If the library is an ATL M1500 in a multiple library stack or an ATL M2500, press the **Level** button to select the level where the drive that requires cleaning is located.
- 7 Press **Drive 1** or **Drive 2**.  
To cancel the operation, press **Cancel**.
- 8 Press **Select**.  
The GUI displays the message **Cleaning in progress**. When the cleaning is done, the GUI displays the **Select Cleaning Cartridge** screen again.
- 9 Press **Back** to return to the **Maintenance** screen.

## Turning Drive Power On or Off (Maintenance Screen)

The **Drive Power** option allows you to turn drive power on or off from the GUI. Use this option to turn off drive power when you are hot-swapping a tape drive.

**Note:** This option is available on both the **Maintenance** screen and the **Quick View Menu** screen. To access this option on the **Quick View Menu** screen, refer to [Turning Drive Power On or Off \(Quick View Menu Screen\)](#) on page 23.

### Turning Drive Power On or Off in an ATL M1500 Library

To turn drive power on or off in an ATL M1500 library:

- 1 Access the **Maintenance** screen (see [Accessing the Maintenance Screen](#) on page 69).
- 2 Press **Drv Pwr**.

The GUI displays the **Tape Drive Power** screen (see [figure 43](#)).

Figure 43 Sample Tape Drive Power Screen

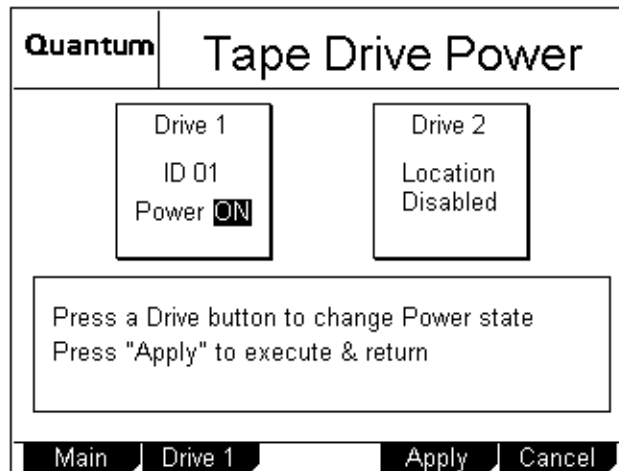

- 3 Press the button that corresponds to the drive you wish to power on or off: **Drive 1** or **Drive 2**.

The GUI displays the currently selected setting in the tape drive box at the top of the screen.

- 4 Press **Apply** to save the change and return to the **Quick View Menu** screen.

To return to the **Quick View Menu** screen without changing the power state of the drive, press **Cancel**.

### Turning Drive Power On or Off in an ATL M2500 Library

To turn drive power on or off in an ATL M2500 library:

- 1 Access the **Maintenance** screen (see [Accessing the Maintenance Screen](#) on page 69).
- 2 Press **Drv Pwr**.

The GUI displays the **Drive Power** screen (see [figure 44](#)).

Figure 44 Drive Power Screen

Quantum	Drive Power	
Drive	Power	
Drive 1 Power	ON	
Drive 2 Power	ON	
Drive 4 Power	ON	

Main Up Down Select Back

- 3 Press the **Up** or **Down** buttons to highlight the drive you wish to power on or off.
- 4 Press **Select**.  
The drive power setting is highlighted.
- 5 Press the **Up** or **Down** buttons to change the current setting.
- 6 When the desired setting is displayed, press **Select**.
- 7 Press **Back** to save the change and return to the **Maintenance** screen.

## Adjusting the Contrast

To adjust the contrast of the GUI:

- 1 Access the **Maintenance** screen (see [Accessing the Maintenance Screen](#) on page 69).
- 2 Press **Contrast**.

The GUI displays the **Adjust Contrast** screen (see [figure 45](#)).

Figure 45 Adjust Contrast Screen

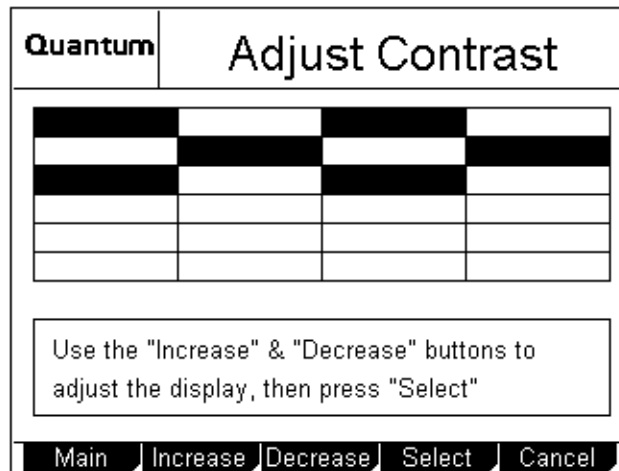

- 3 Press **Increase** or **Decrease** to adjust the contrast as desired.
- 4 When the desired contrast is selected, press **Select**.

To return to the **Maintenance** screen without changing the contrast, press **Cancel**.

Chapter 4 Performing Maintenance Operations  
Adjusting the Contrast

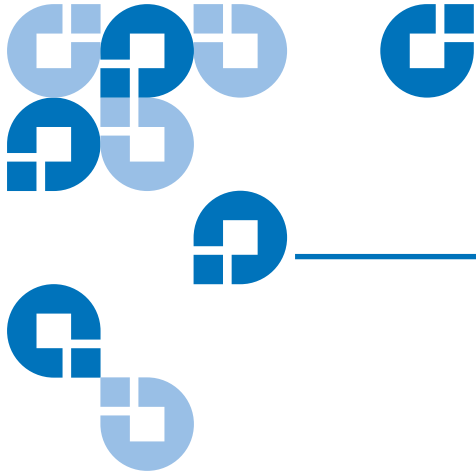

## Chapter 5

# Running Diagnostic Programs

---

This chapter explains how to use the diagnostic programs that are available to all users through the **Diagnostics Menu** screen.

**Note:** This chapter does not describe the diagnostic programs that require a service key. Programs that require a service key are for authorized field service engineers only.

---

## Accessing the Diagnostics Menu Screen

To access the **Diagnostics Menu** screen:

- 1 On the main screen, press **Menu**.

The GUI displays the **Menu** screen.

- 2 Press **Service**.

The GUI displays the **Service Menu** screen.

Figure 46 Service Menu Screen

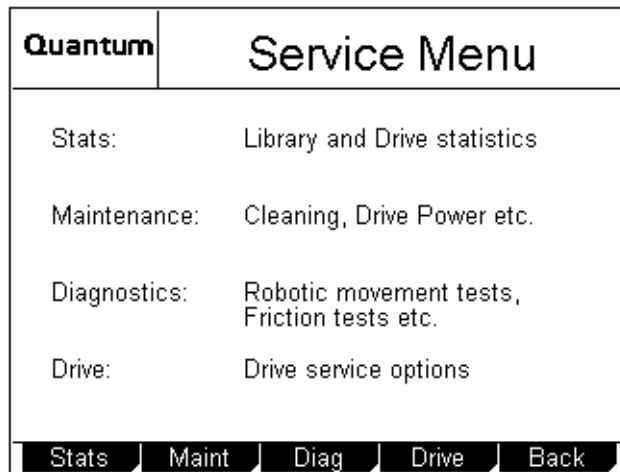

**3** Press **Diag**.

The GUI displays the **Diagnostics Menu** screen (see [figure 47](#)).

Figure 47 Diagnostics Menu Screen

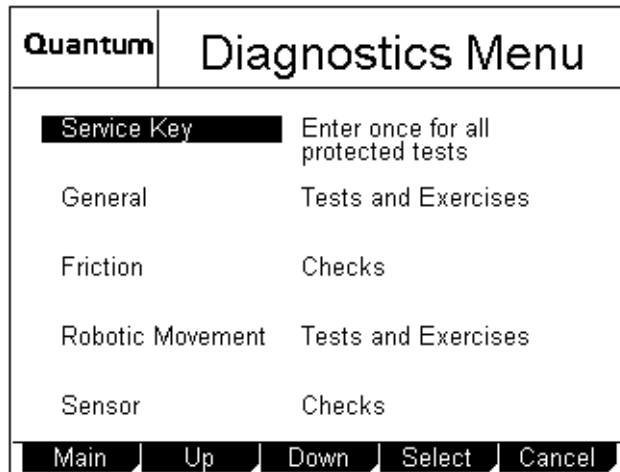



## Running the Barcode Scanner Test

The **Barcode Scanner** test causes the bar code scanner to do a complete inventory of the library, scanning each magazine location for the presence of a valid bar code label.

To run the **Barcode Scanner** test:

- 1 Access the **Diagnostics Menu** screen (see [Accessing the Diagnostics Menu Screen](#)).
- 2 Press the **Up** and **Down** buttons to select **General**.
- 3 Press **Select**.

The GUI displays the **Diags: General** screen (see [figure 48](#)).

Figure 48 Diags:  
General Screen

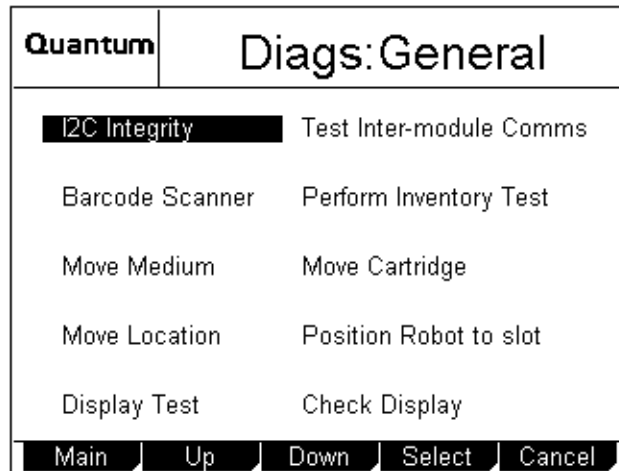

- 4 Press the **Up** and **Down** buttons to select **Barcode Scanner**.
- 5 Press **Select**.

The GUI displays the **Diag: Barcode** screen, which prompts you to set the cycle count (see [figure 49](#)). The rightmost number is highlighted.

Figure 49 Diag:  
Barcode Screen

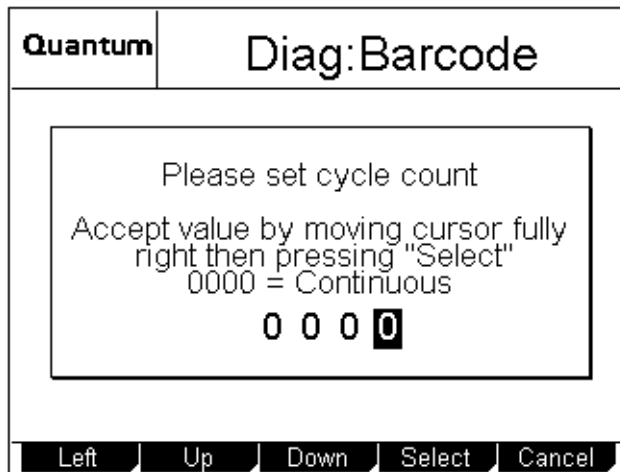

- 6 Press the **Up** and **Down** buttons to change the highlighted number.
- 7 Press **Left** to move the highlight to the next number.
- 8 Repeat steps 6 and 7 as necessary until the desired cycle count number is displayed.

**Note:** Setting the cycle count to 0000 causes the test to run continuously.

- 9 Press **Right** until the cursor is all the way to the right and the **Select** button appears.
- 10 Press **Select** to set the cycle count, or press **Cancel** to return to the **Diags: General** screen without running the **Barcode Scanner** test.

The test starts and the GUI displays a **Running Diag** screen. The test stops automatically after completing the selected number of cycles. When the test is complete, the GUI displays a screen indicating the test status.

To abort the test before it completes the selected number of cycles, press **Stop**.

- 11 Press **Back** to return to the **Diags: General** screen.

## Running the Move Medium Test

The **Move Medium** test simulates the movements performed when a SCSI Move Medium command is received via the SCSI interface.

To run the **Move Medium** test:

- 1 Access the **Diagnostics Menu** screen (see [Accessing the Diagnostics Menu Screen](#) on page 77).
- 2 Press the **Up** and **Down** buttons to select **General**.
- 3 Press **Select**.

The GUI displays the **Diags: General** screen (see [figure 48](#)).

- 4 Press the **Up** or **Down** buttons to select **Move Medium**.
- 5 Press **Select**.

The GUI displays the **Move Cartridge FROM** screen (see [figure 50](#)). A flashing arrow indicates the currently selected source element.

Figure 50 Sample Move Cartridge FROM Screen

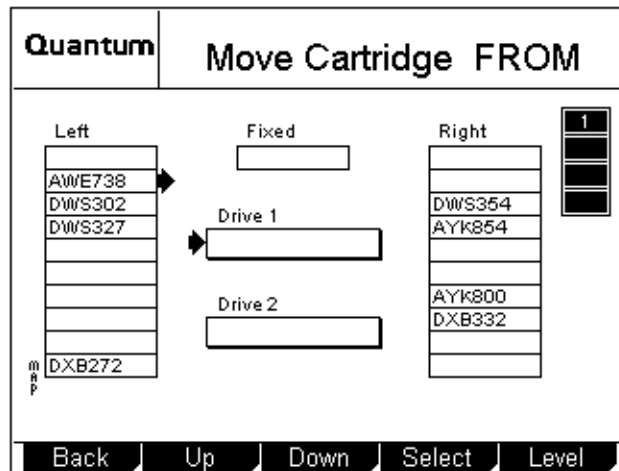

- 6 If the library is an ATL M1500 in a multiple library stack or an ATL M2500, press the **Level** button to select the level where the desired source element is located.
- 7 Press the **Up** and **Down** buttons to select the source element of the cartridge.

- 8 When the flashing arrow is next to the desired source element, press **Select**.

The GUI displays the **Move Cartridge TO** screen (see [figure 51](#)). A flashing arrow indicates the currently selected destination element.

Figure 51 Sample Move Cartridge TO Screen

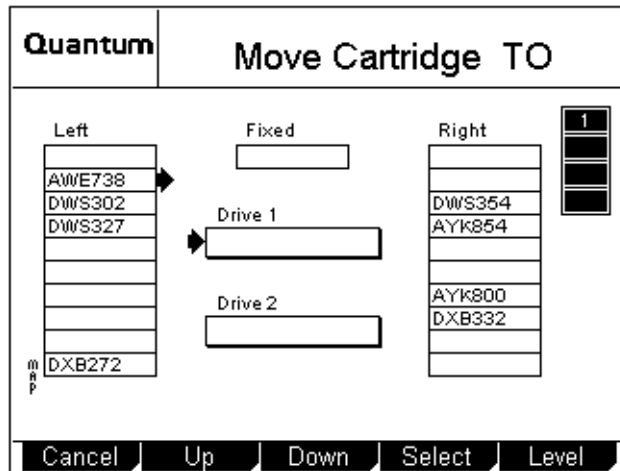

- 9 If the library is an ATL M1500 in a multiple library stack or an ATL M2500, press the **Level** button to select the level where the desired destination element is located.
- 10 Press the **Up** and **Down** buttons to select the destination element for the cartridge.
- 11 When the flashing arrow is next to the desired destination element, press **Select**.

The GUI displays the **Confirm Move Cartridge** screen (see [figure 52](#)).

Figure 52 Sample Confirm Move Cartridge Screen

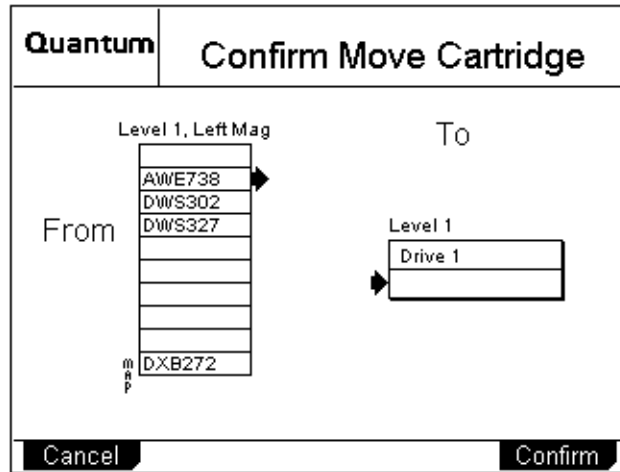

- 12 Verify that the GUI displays the correct source and destination elements, then press **Confirm**.

The GUI displays the **Diag: Move Medium** screen, which prompts you to set the cycle count (see [figure 53](#)). The rightmost number is highlighted.

Figure 53 Diag: Move Medium Screen

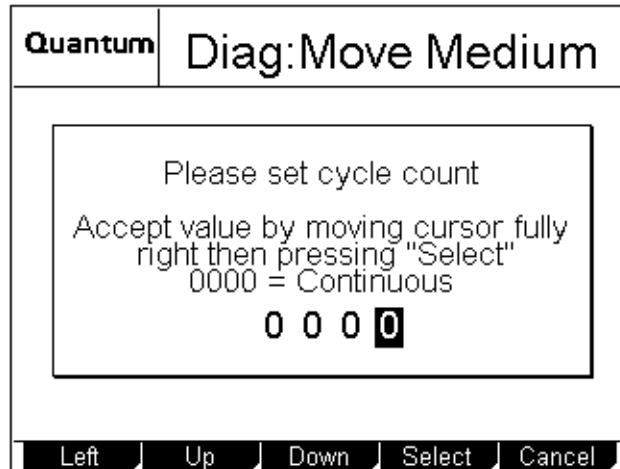

- 13 Press the **Up** and **Down** buttons to change the highlighted number.
- 14 Press **Left** to move the highlight to the next number.

- 15 Repeat steps [13](#) and [14](#) as necessary until the desired cycle count number is displayed.

**Note:** Setting the cycle count to 0000 causes the test to run continuously.

- 16 Press **Right** until the cursor is all the way to the right and the **Select** button appears.
- 17 Press **Select** to set the cycle count, or press **Cancel** to return to the **Diags: General** screen without running the **Move Medium** test.

The test starts and the GUI displays a **Running Diag** screen. The test stops automatically after completing the selected number of cycles. When the test is complete, the GUI displays a screen indicating the test status.

To abort the test before it completes the selected number of cycles, press **Stop**.

- 18 Press **Back**.

The GUI displays the cycle count screen.

- 19 Press **Cancel**, then **Back** to return to the **Diags: General** screen.

---

## Running the Move Location Test

The **Move Location** test is similar to the **Move Medium** test, except that no cartridges are actually moved.

When the **Move Location** test is cycled once, the robotic hand is moved from its current location to the destination location.

When the **Move Location** test is cycled more than once, the robotic hand is repeatedly moved between the destination location and a home location, and will return to the home location at the end of the selected number of

test cycles. The home location depends on whether the destination is a tape drive or a magazine slot:

- If the destination is a tape drive, the home location is slot 1 of the level 1 left magazine.
- If the destination is a magazine slot, the home location is the first installed tape drive.

To run the **Move Location** test:

- 1 Access the **Diagnostics Menu** screen (see [Accessing the Diagnostics Menu Screen](#) on page 77).
- 2 Press the **Up** and **Down** buttons to select **General**.
- 3 Press **Select**.

The GUI displays the **Diags: General** screen (see [figure 48](#) on page 79).

- 4 Press the **Up** or **Down** buttons to select **Move Location**.
- 5 Press **Select**.

The GUI displays the **Diag: Move-Location** screen (see [figure 54](#)).

Figure 54 Sample  
Diag: Move-Location  
Screen

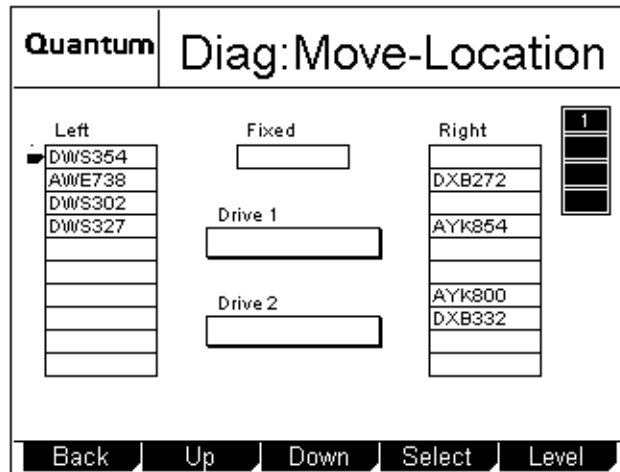

- 6 Press the **Up** and **Down** buttons to select the destination for the robotic hand.
- 7 Press **Select**.

The GUI displays the **Diag: Move Location** screen, which prompts you to set the cycle count (see [figure 55](#)). The rightmost number is highlighted.

Figure 55 Diag: Move Location Screen

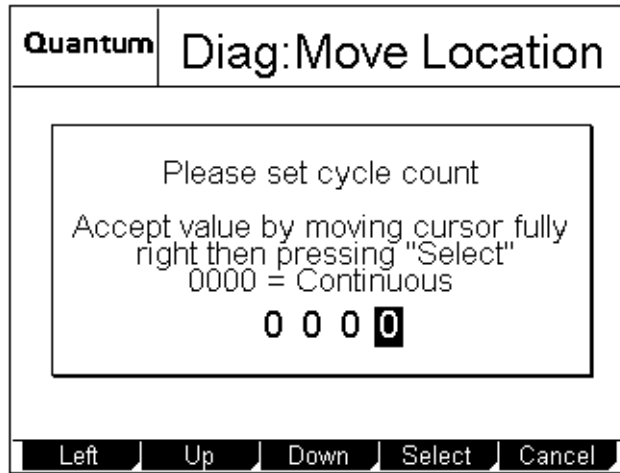

- 8 Press the **Up** and **Down** buttons to change the highlighted number.
- 9 Press **Left** to move the highlight to the next number.
- 10 Repeat steps [8](#) and [9](#) as necessary until the desired cycle count number is displayed.

**Note:** Setting the cycle count to 0000 causes the test to run continuously.

- 11 Press **Right** until the cursor is all the way to the right and the **Select** button appears.
- 12 Press **Select** to set the cycle count, or press **Cancel** to return to the **Diags: General** screen without running the **Move Location** test.

The test starts and the GUI displays a **Running Diag** screen. The test stops automatically after completing the selected number of cycles. When the test is complete, the GUI displays a screen indicating the test status.

To abort the test before it completes the selected number of cycles, press **Stop**.



**13** Press **Back**.

The GUI displays the cycle count screen.

**14** Press **Cancel**, then **Back** to return to the **Diags: General** screen.

---

## Running the Display Test

The **Display Test** allows you to verify that the GUI has no missing pixels and that the two status indicators on the library front panel work correctly.

To run the **Display Test**:

**1** Access the Diagnostics Menu screen (see [Accessing the Diagnostics Menu Screen](#) on page 77).

**2** Press the **Up** and **Down** buttons to select **General**.

**3** Press **Select**.

The GUI displays the **Diags: General** screen (see [figure 48](#) on page 79).

**4** Press the **Up** and **Down** buttons to select **Display Test**.

**5** Press **Select**.

The test starts. The GUI goes dark momentarily, and both of the status indicators flash. This test lasts approximately three seconds.



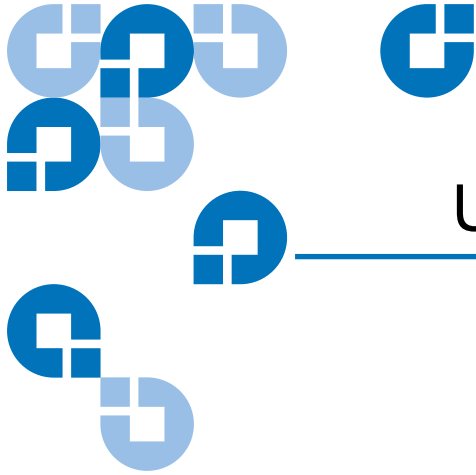

# Updating Drive Firmware

---

This chapter explains how to update drive firmware using the **Service Drive** screen.

**Note:** Before you can update drive firmware, you must insert the cartridge containing the new drive firmware into the library, and move it to the desired storage element (see [Importing and Exporting Cartridges](#) on page 29).

---

## Accessing the Service Drive Screen

To access the Service Drive screen:

- 1 On the main screen, press **Menu**.  
The GUI displays the **Menu** screen.
- 2 Press **Service**.

The GUI displays the **Service Menu** screen (see [figure 56](#)).

Figure 56 Service Menu Screen

Quantum	Service Menu			
Stats:	Library and Drive statistics			
Maintenance:	Cleaning, Drive Power etc.			
Diagnostics:	Robotic movement tests, Friction tests etc.			
Drive:	Drive service options			
Stats	Maint	Diag	Drive	Back

**3** Press **Drive**.

The GUI displays the **Service Drive** screen (see [figure 57](#)).

Figure 57 Service Drive Screen

Quantum	Service Drive	
Update	Update drive firmware from tape	
Main	Update	Back

## Updating the Drive Firmware from Tape

To update the drive firmware from tape:

- 1 Insert the drive firmware cartridge into the library and move it to the desired storage element (see [Importing and Exporting Cartridges](#) on page 29).
- 2 Access the Service Drive screen (see [Accessing the Service Drive Screen](#)).
- 3 Press **Update**.

The GUI displays the **Select Firmware Cartridge** screen (see [figure 58](#)). A flashing arrow indicates the currently selected source element.

Figure 58 Select Firmware Cartridge Screen

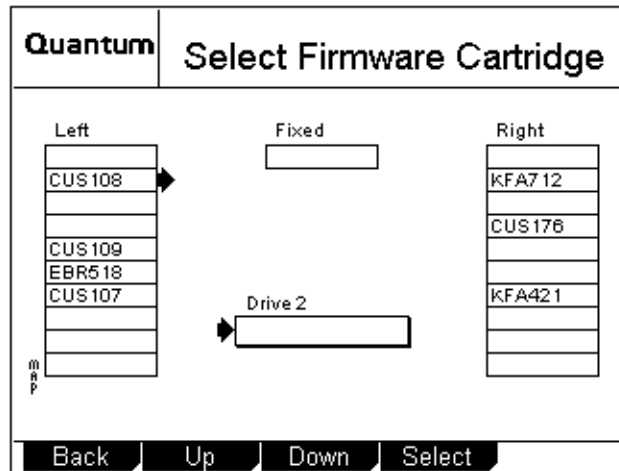

- 4 If the library is an M1500 in a multiple library stack or an M2500, press the **Level** button to select the level where the drive firmware cartridge is located.
- 5 Press the **Up** and **Down** buttons to select the source element that contains the drive firmware cartridge.
- 6 When the flashing arrow is next to the source element that contains the drive firmware cartridge, press **Select**.

The GUI displays the **Select Tape Drive** screen (see [figure 59](#)). A flashing arrow indicates the currently selected drive.

Figure 59 Select Tape Drive Screen

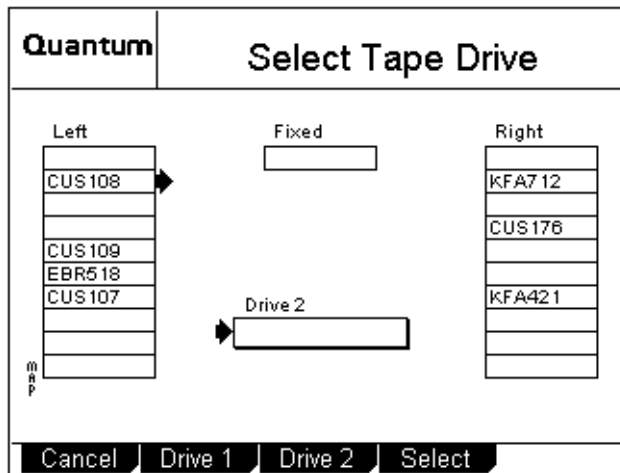

- 7 If the library is an M1500 in a multiple library stack or an M2500, press the **Level** button to select the level where the drive that requires updating is located.
- 8 Press **Drive 1** or **Drive 2**.  
To cancel the operation, press **Cancel**.
- 9 Press **Select**.  
The GUI displays the message **Update in progress**. When the update is done, the GUI displays the message **Drive update complete**. Press any button to continue.
- 10 Press any button.  
The GUI displays the **Select Firmware Cartridge** screen.
- 11 Press **Back** to return to the **Service Drive** screen.

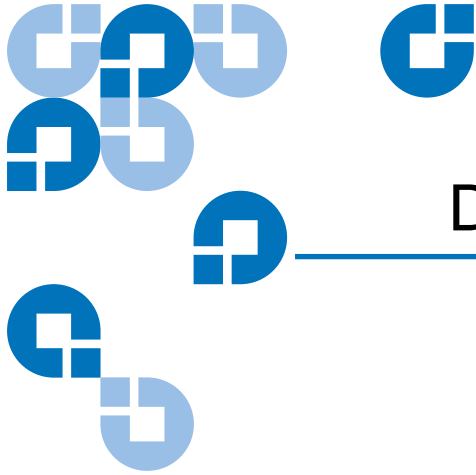

## Chapter 7

# Running the Demonstration Programs

---

The ATL M-Series libraries provide several built-in demonstration programs and a confidence test you can use to check whether the robotics are functioning properly. You can access these programs through the **Demo Programs** screen.

**Caution:** Do not use backup tapes to run these programs. These programs move cartridges around the library; the cartridges will not be in the same position when the program ends.

---

## Accessing the Demo Programs Screen

To access the **Demo Programs** screen:

- 1 On the main screen, press **Menu**.  
The GUI displays the **Menu** screen.
- 2 Press **Demo**.  
The GUI displays the **Demo Programs** screen (see [figure 60](#)).

Figure 60 Demo Programs Screen

Quantum	Demo Programs
<u>Test</u>	<u>Description</u>
Confidence Test	
Demo 1	Move Cart, Random Selection
Demo 2	Move Cart, Sequential Selection
Demo 3	Same slot, Random Selection
Demo 4	Stack Move - Disabled
Demo 5	Stack Move - Disabled
Demo 6	Move to Location, Random Sel

Main Up Down Select Back

## Running the Confidence Test Program

The **Confidence Test** program moves a data cartridge to each tape drive, each magazine, and the fixed slot. The test ends automatically when the cartridge has been placed in all tape drives, magazines, and fixed slots in the library.

To run the **Confidence Test** program:

- 1 Load a single data cartridge into the top left magazine.

**Note:** Leave all the other magazine slots empty.

- 2 Access the **Demo Programs** screen (see [Accessing the Demo Programs Screen](#)).
- 3 Press the **Up** or **Down** buttons to select **Confidence Test**.
- 4 Press **Select**.

The **Confidence Test** program ends automatically when complete.



---

## Running the Demo 1 Program

The **Demo 1** program causes the robot to pick a randomly selected cartridge from its magazine slot and place it in another randomly selected magazine slot.

To run the **Demo 1** program:

- 1 Verify that at least one magazine is installed in the library and that at least one cartridge is present.
- 2 Access the **Demo Programs** screen (see [Accessing the Demo Programs Screen](#)).
- 3 Press the **Up** or **Down** buttons to select **Demo 1**.
- 4 Press **Select**.

The **Demo 1** program starts. This program continues until you press the **Stop** button.

- 5 If desired, include the drives or the fixed slot in the test:
  - a If the library is an ATL M1500 in a multiple library stack or an ATL M2500, press the **Level** button to select the level where the desired drive or fixed slot is located.
  - b Press **Drive 1** or **Drive 2** to include a drive.
  - c Press **Fixed** to include the fixed slot.
- 6 To stop the program, press **Stop**.

The GUI displays a status screen listing the demonstration program number, the number of cycles completed, and the status of the test: pass or fail.

- 7 Press **Back** to return to the **Demo Programs** screen.

---

## Running the Demo 2 Program

The **Demo 2** program causes the robot to pick a cartridge from the first occupied magazine slot and place it in the next vacant magazine slot. The robot then moves to the next occupied slot and repeats the process.

To run the **Demo 2** program:

- 1 Verify that at least one magazine is installed in the library and that at least one cartridge is present.
- 2 Access the **Demo Programs** screen (see [Accessing the Demo Programs Screen](#)).
- 3 Press the **Up** or **Down** buttons to select **Demo 2**.
- 4 Press **Select**.

The **Demo 2** program starts. This program continues until you press the **Stop** button.

- 5 If desired, include the drives or the fixed slot in the test:
  - a If the library is an ATL M1500 in a multiple library stack or an ATL M2500, press the **Level** button to select the level where the desired drive or fixed slot is located.
  - b Press **Drive 1** or **Drive 2** to include a drive.
  - c Press **Fixed** to include the fixed slot.
- 6 To stop the program, press **Stop**.

The GUI displays a status screen listing the demonstration program number, the number of cycles completed, and the status of the test: pass or fail.

- 7 Press **Back** to return to the **Demo Programs** screen.

---

## Running the Demo 3 Program

The **Demo 3** program causes the robot to pick a cartridge from a randomly selected occupied magazine slot and place it back in the same slot. The robot then moves to another randomly selected occupied slot and repeats the process.

To run the **Demo 3** program:

- 1 Verify that at least one magazine is installed in the library and that at least one cartridge is present.
- 2 Access the **Demo Programs** screen (see [Accessing the Demo Programs Screen](#)).
- 3 Press the **Up** or **Down** buttons to select **Demo 3**.
- 4 Press **Select**.

The **Demo 3** program starts. This program continues until you press the **Stop** button.

- 5 If desired, include the drives or the fixed slot in the test:
  - a If the library is an ATL M1500 in a multiple library stack or an ATL M2500, press the **Level** button to select the level where the desired drive or fixed slot is located.
  - b Press **Drive 1** or **Drive 2** to include a drive.
  - c Press **Fixed** to include the fixed slot.
- 6 To stop the program, press **Stop**.

The GUI displays a status screen listing the demonstration program number, the number of cycles completed, and the status of the test: pass or fail.

- 7 Press **Back** to return to the **Demo Programs** screen.

---

## Running the Demo 4 Program

The **Demo 4** program causes the robot to pick a randomly selected cartridge from its magazine slot and place it in another randomly selected magazine slot.

**Note:** This program is for multiple library stacks only.

To run the **Demo 4** program:

- 1 Verify that at least:
  - Two library modules are installed in the stack
  - One magazine is installed in each library module
  - One cartridge is present
- 2 Access the **Demo Programs** screen (see [Accessing the Demo Programs Screen](#) on page 93).
- 3 Press the **Up** or **Down** buttons to select **Demo 4**.
- 4 Press **Select**.

The **Demo 4** program starts. This program continues until you press the **Stop** button.

- 5 To stop the program, press **Stop**.

The GUI displays a status screen listing the demonstration program number, the number of cycles completed, and the status of the test: pass or fail.
- 6 Press **Back** to return to the **Demo Programs** screen.

---

## Running the Demo 5 Program

The **Demo 5** program causes the robot to pick a randomly selected cartridge from its magazine slot and place it in another magazine slot on another level of the stacked library. This test maximizes the use of the StackLink.

<b>Note:</b> This program is for multiple library stacks only.
--

To run the **Demo 5** program:

- 1 Verify that at least:
  - Two library modules are installed in the stack
  - One magazine is installed in each library module
  - One cartridge is present
- 2 Access the **Demo Programs** screen (see [Accessing the Demo Programs Screen](#) on page 93).
- 3 Press the **Up** or **Down** buttons to select **Demo 5**.
- 4 Press **Select**.

The **Demo 5** program starts. This program continues until you press the **Stop** button.
- 5 To stop the program, press **Stop**.

The GUI displays a status screen listing the demonstration program number, the number of cycles completed, and the status of the test: pass or fail.
- 6 Press **Back** to return to the **Demo Programs** screen.

---

## Running the Demo 6 Program

The **Demo 6** program causes the X, Y, and Theta axes to move randomly.

To run the **Demo 6** program:

- 1 Access the **Demo Programs** screen (see [Accessing the Demo Programs Screen](#) on page 93).
- 2 Press the **Up** or **Down** buttons to select **Demo 6**.
- 3 Press **Select**.

The **Demo 6** program starts.

- 4 To stop the program, press **Stop**.

The GUI displays a status screen listing the demonstration program number, the number of cycles completed, and the status of the test: pass or fail.

- 5 Press **Back** to return to the **Demo Programs** screen.

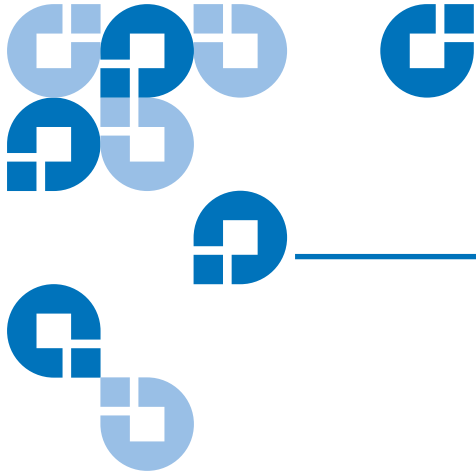

## Appendix A Specifications

This appendix lists the following specifications for the ATL M-Series libraries:

- [Physical Specifications](#)
- [Performance Specifications](#)
- [Reliability Specifications](#)
- [Tape Drive Specifications](#)
- [Environmental Specifications](#)
- [SCSI Specifications](#)

## Physical Specifications

Table 6 Unit  
Dimensions/Weight

	<b>ATL M1500</b>	<b>ATL M2500</b>
<b>Width</b>	19 in. (482 mm)	19 in. (482 mm)
<b>Depth</b>	28.6 in. (726 mm)	28.6 in. (726 mm)
<b>Height</b>	6.9 in. (176 mm)	23.4 in. (595 mm)
<b>Weight</b>	65 lbs. (29 kg) with 2 drives, 2 magazines, and 0 cartridges installed	198 lbs. (90 kg) with 5 drives, 8 magazines, and 0 cartridges installed  205 lbs. (93 kg) with 6 drives, 7 magazines, and 0 cartridges installed

Table 7 Capacities

	<b>ATL M1500</b>	<b>ATL M2500</b>
<b>Number of Tape Drives</b>	Up to 2	Up to 6
<b>Type of Tape Drives</b>	DLT 8000, SDLT 220, SDLT 320, SDLT 600, HP LTO Gen 1, or HP LTO Gen 2	
<b>Number of Tape Cartridges</b>	Up to 20 DLT or SDLT tape cartridges (excluding the fixed slot)  Up to 24 LTO tape cartridges (excluding the fixed slot)	Up to 80 DLT or SDLT tape cartridges (excluding the fixed slots)  Up to 96 LTO tape cartridges (excluding the fixed slots)



	<b>ATL M1500</b>	<b>ATL M2500</b>
<b>Type of Tape Cartridges</b>	For use with: <ul style="list-style-type: none"> <li>• DLT 8000 drives: DLTtape III or DLTtape IV</li> <li>• SDLT 220 drives: DLTtape IV* or Super DLTtape I</li> <li>• SDLT 320 drives: DLTtape IV* or Super DLTtape I</li> <li>• SDLT 600 drives: DLTtape VS1*, Super DLTtape I*, or Super DLTtape II</li> <li>• HP LTO Gen 1 drives: LTO Ultrium cartridges</li> <li>• HP LTO Gen 2 drives: LTO and LTO-2 Ultrium cartridges<sup>†</sup></li> </ul>	
<b>Number of Magazines</b>	Up to 2	Up to 8
<b>Magazine Capacity</b>	Each magazine holds up to 10 DLT or SDLT tape cartridges or up to 12 LTO tape cartridges	
<b>Manual Access Facility</b>	Yes	Yes
<b>Cleaning Cartridge/ Extra Data Slots</b>	1	4
<b>Robot Mounted Bar Code Reader</b>	Yes	Yes
<b>StackLink Scalability</b>	Yes	Yes

\* Read only

† LTO-2 Ultrium cartridges are recommended. Although HP LTO Gen 2 tape drives recognize both LTO and LTO-2 Ultrium cartridges, only LTO-2 cartridges utilize the full capacity of these drives.

## Performance Specifications

Table 8 Performance Specifications

	<b>ATL M1500</b>	<b>ATL M2500</b>
<b>Average Swap Time</b>	Less than 10 seconds	Less than 11 seconds

Table 9 Library Performance

		<b>Data Capacity (Excluding Fixed Slots)*</b>	<b>Maximum Data Capacity (Including Fixed Slots)*</b>	<b>Maximum Data Throughput</b>	<b>Host Interfaces</b>
<b>ATL M1500</b>	<b>DLT 8000</b>	1.6 TB	1.7 TB	86.4 GB/hr	LVD SCSI-2 Fast/Wide
	<b>SDLT 220</b>	4.4 TB	4.6 TB	158.5 GB/hr	LVD Ultra SCSI
	<b>SDLT 320</b>	6.4 TB	6.7 TB	230.4 GB/hr	LVD Ultra 2 SCSI
	<b>SDLT 600</b>	12.0 TB	12.6 TB	460.8 GB/hr	Ultra160 SCSI
	<b>HP LTO Gen 1</b>	4.8 TB	5 TB	216 GB/hr	LVD Ultra 2 SCSI
	<b>HP LTO Gen 2</b>	9.6 TB	10 TB	432 GB/hr	LVD Ultra 3 SCSI

		<b>Data Capacity (Excluding Fixed Slots)*</b>	<b>Maximum Data Capacity (Including Fixed Slots)*</b>	<b>Maximum Data Throughput</b>	<b>Host Interfaces</b>
<b>ATL M2500 (5 drives)</b>	<b>DLT 8000</b>	6.4 TB	6.7 TB	216 GB/hr	LVD SCSI-2 Fast/Wide
	<b>SDLT 220</b>	17.6 TB	18.5 TB	396 GB/hr	LVD Ultra SCSI
	<b>SDLT 320</b>	25.6 TB	26.9 TB	576 GB/hr	LVD Ultra 2 SCSI
	<b>SDLT 600</b>	48.0 TB	50.4 TB	1152 GB/hr	Ultra160 SCSI
	<b>HP LTO Gen 1</b>	19.2 TB	20 TB	540 GB/hr	LVD Ultra 2 SCSI
	<b>HP LTO Gen 2</b>	38.4 TB	40 TB	1080 GB/hr	LVD Ultra 3 SCSI
<b>ATL M2500 (6 drives)</b>	<b>DLT 8000</b>	5.6 TB	5.8 TB	259.2 GB/hr	LVD SCSI-2 Fast/Wide
	<b>SDLT 220</b>	15.4 TB	16.1 TB	475.2 GB/hr	LVD Ultra SCSI
	<b>SDLT 320</b>	22.4 TB	23.4 TB	691.2 GB/hr	LVD Ultra 2 SCSI
	<b>SDLT 600</b>	42.0	43.8	1382.4 GB/ hr	Ultra160 SCSI
	<b>HP LTO Gen 1</b>	16.8 TB	17.4 TB	648 GB/hr	LVD Ultra 2 SCSI
	<b>HP LTO Gen 2</b>	33.6 TB	34.8 TB	1296 GB/hr	LVD Ultra 3 SCSI

\* Assuming 2:1 compression ratios

## Reliability Specifications

Table 10 Reliability Specifications

<b>MSBF</b>	Swap cycles 1,000,000 swaps
<b>MTTR</b>	Less than 20 minutes

## Tape Drive Specifications

Table 11 Tape Drive Specifications

Drive Type	Native Mode		With 2:1 Compression	
	Transfer Rate	Capacity	Transfer Rate	Capacity
DLT 8000*	360 MB/min.	40 GB	720 MB/min.	80 GB
SDLT 220†	660 MB/min.	110 GB	1320 MB/min.	220 GB
SDLT 320‡	960 MB/min.	160 GB	1920 MB/min.	320 GB
SDLT 600	1920+ MB/min.	300 GB	3840+ MB/min.	600 GB
HP LTO Gen 1	900 MB/min.	100 GB	1800 MB/min.	200 GB
HP LTO Gen 2	1800 MB/min.	200 GB.	3600 MB/min.	400 GB

\* Average file access time (from BOT) = 60 seconds

† Average file access time (from BOT) = 70 seconds

‡ Average file access time (from BOT) = 70 seconds

## Environmental Specifications

Table 12 Power

		ATL M1500	ATL M2500
<b>Electrical Input Tolerances</b>	<b>Voltage</b>	88-264 VAC, 47-63 Hz	
	<b>Power</b>	110W (average)	300W (average) (6 drives fitted)

Table 13 Climate

	Temperature (Operating)	Temperature (Non-Operating)
<b>Temperature</b>	+50°F to 104°F (+10°C to +40°C)	-22°F to +122°F (-30°C to +50°F)
<b>Humidity</b>	20% to 80% non-condensing	5% to 90% non-condensing
<b>Altitude</b>	-1,000 to +10,000 feet (-300 to +3,000 meters)	-1,000 to +36,000 feet (-300 to +11,000 meters)

Table 14 Compliance and Certification

<b>Safety</b>	CSA C22.2 950, UL 1950, EN 60950
<b>EMC/RFI</b>	FCC CFR 47-15J (level A), EN55022 (CISPR 22) level B, EN55024 (CISPR 24), VCCI
<b>Agency Markings</b>	CE, VCCI, UL, FCC, CSA

---

## SCSI Specifications

LVD SCSI configurations have a maximum allowable bus length of 12 meters. To determine the cable length of the bus, measure the lengths of the SCSI cables connecting each device to that bus and add those lengths together. To that total length, add 12.25 inches (31.10 cm) for the internal SCSI cable length of each SCSI tape drive.

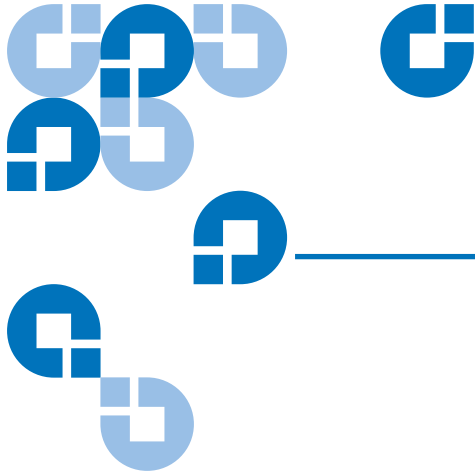

## Appendix B

# Fault Symptom Code (FSC) Dictionary

---

[Table 15](#) lists the fault symptom codes (FSCs) for the ATL M-Series libraries.

Table 15 Fault Symptom Codes

<b>FSC</b>	<b>Name</b>	<b>Description</b>	<b>FRU Name</b>	<b>Confidence %</b>
0001	FSC_DIVIDE_BY_ZERO	A divide by zero exception has occurred	Microcode	100%
0002	FSC_BUS_PARITY_ERROR	A parity error has been detected on the address/data bus	N/A	100%
0003	FSC_NO_MEMORY	Out of memory	Microcode	100%
0004	FSC_FLSBUF_CALLED	_flsbuf was called	Microcode	100%
0005	FSC_GETBUF_CALLED	_getbuf was called	Microcode	100%
0006	FSC_STACK_ERROR	Stack was exhausted	Microcode	100%
0007	FSC_FLOAT_TRAP	Floating point trap	Microcode	100%

Appendix B Fault Symptom Code (FSC) Dictionary

<b>FSC</b>	<b>Name</b>	<b>Description</b>	<b>FRU Name</b>	<b>Confidence %</b>
0008	FSC_BAD_FREE	Free() called on bad memory block	Microcode	100%
0009	FSC_BAD_REALLOC	Realloc() called on bad memory block	Microcode	100%
000A	FSC_HAND_CV	Hand CV check found hand disconnected	Microcode	100%
000B	FSC_SERVO_CV	Servo CV check found servo board disconnected	Microcode	100%
000C	FSC_X_AXIS_CV	X axis CV check found X axis disconnected	Microcode	100%
000D	FSC_Y_AXIS_CV	Y axis CV check found Y axis disconnected	Microcode	100%
000E	FSC_Z_AXIS_CV	Z axis CV check found Z axis disconnected	Microcode	100%
000F	FSC_FP_CV	FP CV check found front panel disconnected	Microcode	100%
0010	FSC_BAD_FREE_TRAILER	Free() found corrupted memory block trailer	Microcode	100%
0011	FSC_BAD_REALLOC_TRAILER	Realloc() found corrupted memory block trailer	Microcode	100%
0012	FSC_NVR_OVERFLOW	NVR capacity exceeded	Microcode	100%
0013	FSC_BAD_MALLOC_BLOCK_HDR	Heap consistency check found corruption	Microcode	100%



<b>FSC</b>	<b>Name</b>	<b>Description</b>	<b>FRU Name</b>	<b>Confidence %</b>
0014	FSC_BAD_MALLOC_BLOCK_TRAILER	Heap consistency check found corruption	Microcode	100%
0015	FSC_WATCHDOG_ERROR	An unexpected non-maskable interrupt has occurred	Microcode	100%
0016	FSC_MALLOC_REQUEST_TOO_BIG	Size passed to malloc too large	Microcode	100%
0017	FSC_CALLOC_REQUEST_TOO_BIG	Size passed to calloc too large	Microcode	100%
0018	FSC_REALLOC_REQUEST_TOO_BIG	Size passed to realloc too large	Microcode	100%
0019	FSC_EXCEPTION_3	Breakpoint instruction executed	Microcode	100%
001A	FSC_EXCEPTION_1	Debug exception occurred	Microcode	100%
001B	FSC_NULL_POINTER_WRITE	Code attempted to write to address 0	Microcode	100%
001C	FSC_EXECUTE_AT_0	Code attempted to execute at address 0	Microcode	100%
001D	FSC_NULL_POINTER_WRITE_NEAR	Code attempted to write to address 0	Microcode	100%
001E	FSC_EXECUTE_AT_0_NEAR	Code attempted to execute at address 0	Microcode	100%
001F	FSC_UNSUPPORTED_SYSTEM_BOARD	Old system boards are no longer supported	Microcode	100%
0020	FSC_NO_OSTIMER_INTERRUPT	OS timer interrupt should have occurred, but hasn't	Microcode	100%

Appendix B Fault Symptom Code (FSC) Dictionary

<b>FSC</b>	<b>Name</b>	<b>Description</b>	<b>FRU Name</b>	<b>Confidence %</b>
0021	FSC_FAN_FAIL_DRIVE_1	Fan failure detected for drive 1 (fan 1)	Microcode	100%
0022	FSC_FAN_FAIL_DRIVE_2	Fan failure detected for drive 2 (fan 2)	Microcode	100%
0023	FSC_FAN_FAIL_DRIVE_3	Fan failure detected for drive 3 (fan 3)	Microcode	100%
0024	FSC_FAN_FAIL_DRIVE_4	Fan failure detected for drive 4 (fan 4)	Microcode	100%
0025	FSC_FAN_FAIL_DRIVE_5	Fan failure detected for drive 5 (fan 5)	Microcode	100%
0026	FSC_FAN_FAIL_DRIVE_6	Fan failure detected for drive 6 (fan 6)	Microcode	100%
0027	FSC_FAN_FAIL_DRIVE_7	Fan failure detected for drive 7 (fan 7)	Microcode	100%
0028	FSC_FAN_FAIL_DRIVE_8	Fan failure detected for drive 8 (fan 8)	Microcode	100%
0029	FSC_FAN_FAIL_PSU	Either fan failure or power ok failure detected for PSU (fan 9)	Microcode	100%
002A	FSC_FAN_FAIL_MODULE	Fan failure detected for electronics module (fan 10)	Microcode	100%
002B	FSC_FAN_FAIL_PSU2	Fan failure or power ok failure detected for second PSU (fan 11)	Microcode	100%
002C	FSC_FAN_FAIL_MODULE2	Fan failure detected for second electronics module (fan 12)	Microcode	100%

<b>FSC</b>	<b>Name</b>	<b>Description</b>	<b>FRU Name</b>	<b>Confidence %</b>
002D	FSC_MAC_ADDR_ERROR	MAC address could not be validated and must be reprogrammed	Microcode	100%
002E	FSC_UNSUPPORTED_FP	VAR 1 front panels are not supported	Microcode	100%
1000	FSC_FPGA_INIT_STUCK_HI	FPGA INIT pin was detected as being high when it should have been low	System	100%
1001	FSC_FPGA_INIT_NOT_HI	FPGA INIT pin was detected as being low when it should have been high	System	100%
1002	FSC_FPGA_DONE_STUCK_HI	FPGA DONE pin was detected as being high when it should have been low	System	100%
1003	FSC_FPGA_DONE_NOT_HI	FPGA DONE pin was detected as being low when it should have been high	System	100%
2000	FSC_DLT_INIT_FAILED	DLT initialization failed	Microcode	100%
2001	FSC_DRIVE_TIMEOUT_1	Drive time out waiting for status (drive 1)	Drive	100%
2002	FSC_DRIVE_TIMEOUT_2	Drive time out waiting for status (drive 2)	Drive	100%
2003	FSC_DRIVE_TIMEOUT_3	Drive time out waiting for status (drive 3)	Drive	100%
2004	FSC_DRIVE_TIMEOUT_4	Drive time out waiting for status (drive 4)	Drive	100%

<b>FSC</b>	<b>Name</b>	<b>Description</b>	<b>FRU Name</b>	<b>Confidence %</b>
2005	FSC_DRIVE_TIMEOUT_5	Drive time out waiting for status (drive 5)	Drive	100%
2006	FSC_DRIVE_TIMEOUT_6	Drive time out waiting for status (drive 6)	Drive	100%
2007	FSC_DRIVE_TIMEOUT_7	Drive time out waiting for status (drive 7)	Drive	100%
2008	FSC_DRIVE_TIMEOUT_8	Drive time out waiting for status (drive 8)	Drive	100%
2009	FSC_DRIVE_OLD_SYSTEM_BOARD	Requires newer version of system board	System	100%
200A	FSC_DRIVE_NOT_PRESENT_1	Drive caddy not present (drive 1)	Drive	100%
200B	FSC_DRIVE_NOT_PRESENT_2	Drive caddy not present (drive 2)	Drive	100%
200C	FSC_DRIVE_NOT_PRESENT_3	Drive caddy not present (drive 3)	Drive	100%
200D	FSC_DRIVE_NOT_PRESENT_4	Drive caddy not present (drive 4)	Drive	100%
200E	FSC_DRIVE_NOT_PRESENT_5	Drive caddy not present (drive 5)	Drive	100%
200F	FSC_DRIVE_NOT_PRESENT_6	Drive caddy not present (drive 6)	Drive	100%
2010	FSC_DRIVE_NOT_PRESENT_7	Drive caddy not present (drive 7)	Drive	100%
2011	FSC_DRIVE_NOT_PRESENT_8	Drive caddy not present (drive 8)	Drive	100%
2012	FSC_INVALID_STUFF_BYTE_1	Invalid byte received from drive 1	Drive	100%

<b>FSC</b>	<b>Name</b>	<b>Description</b>	<b>FRU Name</b>	<b>Confidence %</b>
2013	FSC_INVALID_STUFF_BYTE_2	Invalid byte received from drive 2	Drive	100%
2014	FSC_INVALID_STUFF_BYTE_3	Invalid byte received from drive 3	Drive	100%
2015	FSC_INVALID_STUFF_BYTE_4	Invalid byte received from drive 4	Drive	100%
2016	FSC_INVALID_STUFF_BYTE_5	Invalid byte received from drive 5	Drive	100%
2017	FSC_INVALID_STUFF_BYTE_6	Invalid byte received from drive 6	Drive	100%
2018	FSC_INVALID_STUFF_BYTE_7	Invalid byte received from drive 7	Drive	100%
2019	FSC_INVALID_STUFF_BYTE_8	Invalid byte received from drive 8	Drive	100%
201A	FSC_INVALID_PACKET_1	Invalid packet received from drive 1	Drive	100%
201B	FSC_INVALID_PACKET_2	Invalid packet received from drive 2	Drive	100%
201C	FSC_INVALID_PACKET_3	Invalid packet received from drive 3	Drive	100%
201D	FSC_INVALID_PACKET_4	Invalid packet received from drive 4	Drive	100%
201E	FSC_INVALID_PACKET_5	Invalid packet received from drive 5	Drive	100%
201F	FSC_INVALID_PACKET_6	Invalid packet received from drive 6	Drive	100%
2020	FSC_INVALID_PACKET_7	Invalid packet received from drive 7	Drive	100%

<b>FSC</b>	<b>Name</b>	<b>Description</b>	<b>FRU Name</b>	<b>Confidence %</b>
2021	FSC_INVALID_PACKET_8	Invalid packet received from drive 8	Drive	100%
2022	FSC_NOT_IMPLEMENTED	The requested function is not implemented in the drive type	Drive	100%
2023	FSC_DRIVE_NO_RESOURCE	Couldn't get semaphore from OS	Microcode	100%
2024	FSC_COMMAND_FAILED_1	Response packet received from drive 1 indicates command failed	Drive	100%
2025	FSC_COMMAND_FAILED_2	Response packet received from drive 2 indicates command failed	Drive	100%
2026	FSC_COMMAND_FAILED_3	Response packet received from drive 3 indicates command failed	Drive	100%
2027	FSC_COMMAND_FAILED_4	Response packet received from drive 4 indicates command failed	Drive	100%
2028	FSC_COMMAND_FAILED_5	Response packet received from drive 5 indicates command failed	Drive	100%
2029	FSC_COMMAND_FAILED_6	Response packet received from drive 6 indicates command failed	Drive	100%

<b>FSC</b>	<b>Name</b>	<b>Description</b>	<b>FRU Name</b>	<b>Confidence %</b>
202A	FSC_COMMAND_FAILED_7	Response packet received from drive 7 indicates command failed	Drive	100%
202B	FSC_COMMAND_FAILED_8	Response packet received from drive 8 indicates command failed	Drive	100%
202C	FSC_SEAGATE_SCSI_CMD_ERROR_1	Response packet received from drive 1 indicates command failed	Drive	100%
202D	FSC_SEAGATE_SCSI_CMD_ERROR_2	Response packet received from drive 2 indicates command failed	Drive	100%
202E	FSC_SEAGATE_SCSI_CMD_ERROR_3	Response packet received from drive 3 indicates command failed	Drive	100%
202F	FSC_SEAGATE_SCSI_CMD_ERROR_4	Response packet received from drive 4 indicates command failed	Drive	100%
2030	FSC_SEAGATE_SCSI_CMD_ERROR_5	Response packet received from drive 5 indicates command failed	Drive	100%
2031	FSC_SEAGATE_SCSI_CMD_ERROR_6	Response packet received from drive 6 indicates command failed	Drive	100%

<b>FSC</b>	<b>Name</b>	<b>Description</b>	<b>FRU Name</b>	<b>Confidence %</b>
2032	FSC_SEAGATE_SCSI_CMD_ERROR_7	Response packet received from drive 7 indicates command failed	Drive	100%
2033	FSC_SEAGATE_SCSI_CMD_ERROR_8	Response packet received from drive 8 indicates command failed	Drive	100%
2034	FSC_HP_BUSY_1	Response packet received from drive 1 indicates drive busy	Drive	100%
2035	FSC_HP_BUSY_2	Response packet received from drive 2 indicates drive busy	Drive	100%
2036	FSC_HP_BUSY_3	Response packet received from drive 3 indicates drive busy	Drive	100%
2037	FSC_HP_BUSY_4	Response packet received from drive 4 indicates drive busy	Drive	100%
2038	FSC_HP_BUSY_5	Response packet received from drive 5 indicates drive busy	Drive	100%
2039	FSC_HP_BUSY_6	Response packet received from drive 6 indicates drive busy	Drive	100%
203A	FSC_HP_BUSY_7	Response packet received from drive 7 indicates drive busy	Drive	100%
203B	FSC_HP_BUSY_8	Response packet received from drive 8 indicates drive busy	Drive	100%



<b>FSC</b>	<b>Name</b>	<b>Description</b>	<b>FRU Name</b>	<b>Confidence %</b>
203C	FSC_DRIVE_IF_NVR_MISCONFIG_1	The drive interface type for drive 1 is misconfigured in NVR	NVR	100%
203D	FSC_DRIVE_IF_NVR_MISCONFIG_2	The drive interface type for drive 2 is misconfigured in NVR	NVR	100%
203E	FSC_DRIVE_IF_NVR_MISCONFIG_3	The drive interface type for drive 3 is misconfigured in NVR	NVR	100%
203F	FSC_DRIVE_IF_NVR_MISCONFIG_4	The drive interface type for drive 4 is misconfigured in NVR	NVR	100%
2040	FSC_DRIVE_IF_NVR_MISCONFIG_5	The drive interface type for drive 5 is misconfigured in NVR	NVR	100%
2041	FSC_DRIVE_IF_NVR_MISCONFIG_6	The drive interface type for drive 6 is misconfigured in NVR	NVR	100%
2042	FSC_DRIVE_IF_NVR_MISCONFIG_7	The drive interface type for drive 7 is misconfigured in NVR	NVR	100%
2043	FSC_DRIVE_IF_NVR_MISCONFIG_8	The drive interface type for drive 8 is misconfigured in NVR	NVR	100%
2100	FSC_I2C_FAILED_INIT	I <sup>2</sup> C interface failed to initialize	Microcode	100%
2101	FSC_I2C_TIMEOUT_BUS_BUSY	Timed out waiting for I <sup>2</sup> C bus to go not busy	I <sup>2</sup> C	100%
2102	FSC_I2C_NO_ACKNOWLEDGEMENT	No acknowledge received from slave	I <sup>2</sup> C	100%

Appendix B Fault Symptom Code (FSC) Dictionary

<b>FSC</b>	<b>Name</b>	<b>Description</b>	<b>FRU Name</b>	<b>Confidence %</b>
2103	FSC_I2C_UNABLE_TO_SEND_MESSAGE	Exceeded retry limit while trying to send message	I <sup>2</sup> C	100%
2104	FSC_I2C_NO_RESPONSE_FROM_HARDWARE	Expected response from hardware was not received	I <sup>2</sup> C	100%
2105	FSC_I2C_UNKNOWN_MESSAGE_DESTINATION	Message received from I <sup>2</sup> C bus but destination is unknown	I <sup>2</sup> C	100%
2106	FSC_I2C_MESSAGE_TOO_BIG	Message to send over I <sup>2</sup> C bus is too big (see path)	I <sup>2</sup> C	100%
2107	FSC_I2C_RCV_MESSAGE_TOO_BIG	Message received over I <sup>2</sup> C bus is too big	I <sup>2</sup> C	100%
2108	FSC_I2C_MAILBOX_FULL	I <sup>2</sup> C mailbox is full	I <sup>2</sup> C	100%
2109	FSC_I2C_INVALID_RCV_ADDRESS	Receiver address in I <sup>2</sup> C message incorrect	I <sup>2</sup> C	100%
210A	FSC_I2C_STUCK_INTERRUPT	Pending interrupt status not reset	I <sup>2</sup> C	100%
2200	FSC_UI_NO_RESOURCE	UI task initialization failed	Microcode	100%
2201	FSC_UI_QUEUE_FULL	UI queue full	Microcode	100%
2202	FSC_UI_ACTION_IMPOSSIBLE	The UI is not in the correct state to perform the requested action	Microcode	100%
2301	FSC_BARCODE_TIMEOUT	Timed out waiting for data from barcode reader	Hand	100%

<b>FSC</b>	<b>Name</b>	<b>Description</b>	<b>FRU Name</b>	<b>Confidence %</b>
2302	FSC_BARCODE_READER_NOT_INSTALLED	Did not detect barcode reader	Hand	100%
2303	FSC_BARCODE_NO_READ	Barcode reader did not find a barcode	Microcode	100%
2400	FSC_LIBRARIAN_NO_RESOURCE	Librarian task initialization failed	Microcode	100%
2401	FSC_LIBRARIAN_BAD_MESSAGE	Librarian task received an unknown or unexpected message		
2402	FSC_LIBRARIAN_QUEUE_FULL	Librarian queue full	Microcode	100%
2403	FSC_LIBRARIAN_SRC_EMPTY	Source is empty	Microcode	100%
2404	FSC_LIBRARIAN_DEST_FULL	Destination is full	Microcode	100%
2405	FSC_LIBRARIAN_BAD_ELEMENT	Element address supplied is invalid	Microcode	100%
2406	FSC_LIBRARIAN_SERVO_INIT_FAILED	Servo initialization not complete (Librarian unsure of Servo status)	Microcode	100%
2407	FSC_LIBRARIAN_SERVO_DISABLED	Servo turned off due to failure (Librarian unsure of Servo status)	Microcode	100%
2408	FSC_LIBRARIAN_DEST_ABSENT	Destination slot not present (magazine or drive removed)	Microcode	100%
2409	FSC_LIBRARIAN_MAG_REMOVED	Magazine removed when door was shut	Microcode	100%

<b>FSC</b>	<b>Name</b>	<b>Description</b>	<b>FRU Name</b>	<b>Confidence %</b>
240A	FSC_LIBRARIAN_MAG_INSERTED	Magazine inserted when no access to it	Microcode	100%
240B	FSC_LIBRARIAN_NO_FREE_SLOTS	Demo stopped; no slot available for cartridge destination	Microcode	100%
240C	FSC_LIBRARIAN_NO_CARTRIDGES	Sequence stopped; no cartridge available to perform requested action	Microcode	100%
240D	FSC_LIBRARIAN_ROGUE_CARTRIDGE	Librarian uncertain of cartridge origin	Microcode	100%
240E	FSC_LIBRARIAN_CARTRIDGE_IN_SHUTTLE	Manual intervention required to remove cartridge from the shuttle	Microcode	100%
240F	FSC_LIBRARIAN_ACTION_IMPOSSIBLE_CARTRIDGE_IN_HAND	The requested move can not be performed because there is a cartridge in the hand	Microcode	100%
2410	FSC_LIBRARIAN_ACTION_IMPOSSIBLE_CARTRIDGE_IN_SHUTTLE	The requested move can not be performed because there is a cartridge in the shuttle	Microcode	100%
2411	FSC_LIBRARIAN_NO_CLEANING_TAPES	Auto-clean can not be performed as there are no cleaning tapes	Microcode	100%
2412	FSC_LIBRARIAN_CLEANING_TAPES_IN_USE	Auto-clean can not be performed as all the cleaning tapes are in use	Microcode	100%
2413	FSC_LIBRARIAN_SRC_ABSENT	Source slot not present (magazine or drive removed)	Microcode	100%

<b>FSC</b>	<b>Name</b>	<b>Description</b>	<b>FRU Name</b>	<b>Confidence %</b>
2414	FSC_LIBRARIAN_NO_START_SLOT	Demo unable to select random start slot (try re-running demo)	Microcode	100%
2415	FSC_LIBRARIAN_AUTOCLEAN_IN_PROGRESS	Move medium attempted to drive that is being auto cleaned	Microcode	100%
2416	FSC_LIBRARIAN_BAD_MESSAGE_PARAMETER	Bad parameter in Librarian message	Microcode	100%
2417	FSC_LIBRARIAN_DEDICATED_CLEANER	Fixed slot reserved for dedicated cleaner; not for general use	Microcode	100%
2418	FSC_LIBRARIAN_ROBOT_NOT_READY	Requested action can not be performed; robot is busy or in use	Microcode	100%
2419	FSC_LIBRARIAN_ILLEGAL_MAG_INSERTED	Magazine 5 present in 6 drive, 7 magazine configuration	Microcode	100%
241A	FSC_LIBRARIAN_NON_HOMOGENOUS_STACK	Stack contains modules configured for different media to stack-master	Microcode	100%
241B	FSC_LIBRARIAN_ILLEGAL_BUILD_FIXED_SLOT_FITTED	Fixed slot detected when library configured for 6 drive operation	Microcode	100%
241C	FSC_LIBRARIAN_ILLEGAL_BUILD_NO_FIXED_SLOT_FITTED	No fixed slot detected when library configured for 5 drive operation	Microcode	100%
241D	FSC_LIBRARIAN_ILLEGAL_BUILD_MAGAZINE_FIXED	Magazine 5 detected when library configured for 6 drive operation	Microcode	100%

Appendix B Fault Symptom Code (FSC) Dictionary

<b>FSC</b>	<b>Name</b>	<b>Description</b>	<b>FRU Name</b>	<b>Confidence %</b>
241E	FSC_LIBRARIAN_ILLEGAL_BUILD_DRIVE_FITTED	Drive 3 detected when library configured for 5 drive operation	Microcode	100%
2500	FSC_SCSI_NO_RESOURCE	SCSI task initialization failed	Microcode	100%
2501	FSC_SCSI_BAD_MESSAGE	SCSI task received a bad message	Microcode	100%
2502	FSC_SCSI_QUEUE_FULL	SCSI queue full	Microcode	100%
2503	FSC_SCSI_NO_FAS366	FAS366 not detected	Servo/SCSI	100%
2504	FSC_SCSI_INVALID_PAGE_CODE	Bad page code in send diagnostic	Host	100%
2600	FSC_SERVO_NO_RESOURCE	SERVO task initialization failed	Microcode	100%
2601	FSC_SERVO_QUEUE_FULL	SERVO queue full	Microcode	100%
2602	FSC_SERVO_X_AXIS_NOT_IN_POSITION	The X axis failed to get to its target position		
2603	FSC_SERVO_Y_AXIS_NOT_IN_POSITION	The Y axis failed to get to its target position		
2604	FSC_SERVO_THETA_AXIS_NOT_IN_POSITION	The THETA axis failed to get to its target position		
2605	FSC_SERVO_PICKER_AXIS_NOT_IN_POSITION	The PICKER axis failed to get to its target position		
2606	FSC_SERVO_SHUTTLE_AXIS_NOT_IN_POSITION	The Shuttle axis failed to get to its target position		

<b>FSC</b>	<b>Name</b>	<b>Description</b>	<b>FRU Name</b>	<b>Confidence %</b>
2607	FSC_SERVO_Z_AXIS_NOT_IN_POSITION	The Z axis failed to get to its target position		
2608	FSC_SERVO_X_TACHO_COUNTER_FAILURE	The X axis tacho counter failed to clear at power-on	System PWA	100%
2609	FSC_SERVO_Y_TACHO_COUNTER_FAILURE	The Y axis tacho counter failed to clear at power-on	System PWA	100%
260A	FSC_SERVO_THETA_TACHO_COUNTER_FAILURE	The Theta axis tacho counter failed to clear at power-on	Hand PWA System PWA	80% 20%
260B	FSC_SERVO_PICKER_TACHO_COUNTER_FAILURE	The Picker axis tacho counter failed to clear at power-on	Hand PWA System PWA	80% 20%
260C	FSC_SERVO_SHUTTLE_TACHO_COUNTER_FAILURE	The Shuttle axis tacho counter failed to clear at power-on	Hand PWA System PWA	80% 20%
260D	FSC_SERVO_Z_TACHO_COUNTER_FAILURE	The Z axis tacho counter failed to clear at power-on	Hand PWA System PWA	80% 20%
260E	FSC_SERVO_UNABLE_TO_MOVE_HAND	The hand could not be returned to the XY center during power-on		
260F	FSC_SERVO_INVALID_COMMAND_CODE_RECEIVED	The Servo task has received an invalid command code	Microcode	100%
2610	FSC_SERVO_FAILED_TO_GET_CARTRIDGE	The pick action 'completed' with no cartridge detected in the hand		

<b>FSC</b>	<b>Name</b>	<b>Description</b>	<b>FRU Name</b>	<b>Confidence %</b>
2611	FSC_SERVO_FAILED_TO_OFFLOAD_CARTRIDGE	The put action 'completed' with the cartridge still in the hand		
2612	FSC_SERVO_CARTRIDGE_IN_THE_HAND	Requested action can't be carried out with a cartridge in the hand		
2613	FSC_SERVO_NO_CARTRIDGE_IN_THE_HAND	Requested action can't be carried out without a cartridge in the hand		
2614	FSC_SERVO_AXIS_NOT_INITIALIZED	Command cannot be executed without first initializing the axis		
2615	FSC_SERVO_NVR_THETA_DATA_INVALID	Theta NVR data has been corrupted, or not yet initialized		
2616	FSC_SERVO_NVR_FRICTION_DATA_INVALID	Axis friction NVR data has been corrupted, or not yet initialized		
2617	FSC_SERVO_NVR_OFFSET_DATA_INVALID	Axis offset NVR data has been corrupted		
2618	FSC_SERVO_NVR_BUILD_DATA_INVALID	The build level NVR data has been corrupted, or not initialized		
2619	FSC_SERVO_NVR_DATA_INVALID	An error has been detected in the servo NVR		
261A	FSC_SERVO_SOURCE_EMPTY	The pick action 'completed' with no cartridge detected in the hand		



<b>FSC</b>	<b>Name</b>	<b>Description</b>	<b>FRU Name</b>	<b>Confidence %</b>
261B	FSC_SERVO_HAND_SENSOR_FAILURE	The pick action 'completed' with no cartridge detected in the hand		
261C	FSC_SERVO_PICKER_UNABLE_TO_ENGAGE	The pick action 'completed' with no cartridge detected in the hand		
261D	FSC_SERVO_PICKER_AXIS_JAMMED	The Picker will not move in either direction		
261E	FSC_SERVO_PICK_ACTION_STALLED	The Picker could not get the cartridge to its required position		
261F	FSC_SERVO_SHUTTLE_SENSOR_FAILURE	The box's shuttle sensor was not detected during shuttle calibration		
2620	FSC_SERVO_NVR_SHUTTLE_DATA_INVALID	Shuttle NVR data has been corrupted, or not yet initialized		
2621	FSC_SERVO_X_AXIS_JAMMED	The X axis cannot be moved properly in either direction		
2622	FSC_SERVO_FAILED_TO_RAISE_DRIVE_HUB	The drive hub could not be raised into position on cartridge load		
2623	FSC_SERVO_CARTRIDGE_STILL_LATCHED	The cartridge is still being retained by the drive		

<b>FSC</b>	<b>Name</b>	<b>Description</b>	<b>FRU Name</b>	<b>Confidence %</b>
2624	FSC_SERVO_CLEANER_SLOT_NOT_ACCESSIBLE	The (NVR spec'd) XY build does not provide access to the cleaner slot	XY NVR	50% 50%
2625	FSC_SERVO_SHUTTLE_NOT_CALIBRATED	The shuttle's vertical position is still unknown		
2626	FSC_SERVO_THETA_CALIBRATION_ERROR	The Theta angles are out of specification after calibration attempt		
2627	FSC_SERVO_X_CALIBRATION_ERROR	The X axis did not travel the minimum distance when calibrating		
2628	FSC_SERVO_Y_CALIBRATION_ERROR	The Y axis did not travel the minimum distance when calibrating		
2629	FSC_SERVO_PICKER_JAM_RECOVERED	Picker jam occurring, being recovered, but retry now exhausted		
262A	FSC_SERVO_THETA_SENSOR_0_FAILURE	The Theta sensor closest to the RH magazine failed to switch		
262B	FSC_SERVO_THETA_SENSOR_1_FAILURE	The Theta sensor closest to the LH magazine failed to switch		
262C	FSC_SERVO_X_AXIS_SENSOR_FAILURE	The X axis sensor could not be detected changing state		

<b>FSC</b>	<b>Name</b>	<b>Description</b>	<b>FRU Name</b>	<b>Confidence %</b>
262D	FSC_SERVO_Y_AXIS_SENSOR_FAILURE	The Y axis sensor could not be detected changing state		
262E	FSC_SERVO_PICKER_CALIBRATION_ERROR	The Picker axis did not travel the minimum distance when calibrating		
262F	FSC_SERVO_X_FRICTION_TOO_HIGH	The X axis friction is too high for normal operation		
2630	FSC_SERVO_Y_FRICTION_TOO_HIGH	The Y axis friction is too high for normal operation		
2631	FSC_SERVO_THETA_FRICTION_TOO_HIGH	The Theta axis friction is too high for normal operation		
2632	FSC_SERVO_PICKER_FRICTION_TOO_HIGH	The Picker axis friction is too high for normal operation		
2633	FSC_SERVO_Z_CALIBRATION_ERROR	The Z axis did not travel the minimum distance when calibrating		
2634	FSC_SERVO_MAGAZINE_PARTIALLY_INSERTED	The inserted magazine has not been pushed fully home		
2635	FSC_SERVO_Z_FRICTION_TOO_HIGH	The Z axis friction is too high for normal operation		
2636	FSC_SERVO_SHUTTLE_CALIBRATION_ERROR	The shuttle's X axis offset is too great		

<b>FSC</b>	<b>Name</b>	<b>Description</b>	<b>FRU Name</b>	<b>Confidence %</b>
2637	FSC_SERVO_SHUTTLE_PICKER_CALIBRATION_ERROR	The shuttle is set too far back on the Picker axis		
2638	FSC_SERVO_GROSS_POSITION_ERROR	One of the axes has suffered a gross position error		
2639	FSC_SERVO_SLOT_CALIBRATION_ERROR	The cartridge position error detected on the Y axis is too great		
263A	FSC_SERVO_DRIVE_FXD_SLOT_CALIBRATION_ERROR	The cartridge position error detected on the X axis is too great		
263B	FSC_SERVO_CLEANING_TAPE_EXPIRED	The cleaning tape in use has expired		
263C	FSC_SERVO_NOT_CLEANING_TAPE	The auto-clean cycle has loaded a non-cleaning or invalid tape		
263D	FSC_SERVO_SHUTTLE_NOT_IN_POSITION	The shuttle has not been detected opposite the Picker during calibration		
263E	FSC_SERVO_CARTRIDGE_NOT_FULLY_HOME_IN_SHUTTLE	The cartridge is not fully in the shuttle, manual intervention required		
263F	FSC_SERVO_CARTRIDGE_NOT_FULLY_HOME_IN_DRIVE	The cartridge is not fully in the drive, manual intervention and power cycle are required		

<b>FSC</b>	<b>Name</b>	<b>Description</b>	<b>FRU Name</b>	<b>Confidence %</b>
2640	FSC_SERVO_MANUAL_INTERVENTION_REQUIRED	Detail is not known, but manual intervention and power cycle are required		
2641	FSC_SERVO_FIXED_SLOT_FITTED	The fixed slot check has detected a fixed slot		
2680	FSC_SERVO_DRIVE_1_HARDWARE_ERROR	Drive 1 has reported a hardware error	Drive 1	100%
2681	FSC_SERVO_DRIVE_2_HARDWARE_ERROR	Drive 2 has reported a hardware error	Drive 2	100%
2682	FSC_SERVO_DRIVE_3_HARDWARE_ERROR	Drive 3 has reported a hardware error	Drive 3	100%
2683	FSC_SERVO_DRIVE_4_HARDWARE_ERROR	Drive 4 has reported a hardware error	Drive 4	100%
2684	FSC_SERVO_DRIVE_5_HARDWARE_ERROR	Drive 5 has reported a hardware error	Drive 5	100%
2685	FSC_SERVO_DRIVE_6_HARDWARE_ERROR	Drive 6 has reported a hardware error	Drive 6	100%
2686	FSC_SERVO_DRIVE_7_HARDWARE_ERROR	Drive 7 has reported a hardware error	Drive 7	100%
2687	FSC_SERVO_DRIVE_8_HARDWARE_ERROR	Drive 8 has reported a hardware error	Drive 8	100%
2688	FSC_SERVO_DRIVE_1_HANDLE_LOCKED_OUT	Drive 1 will not allow the handle to be operated as required	Drive 1	100%
2689	FSC_SERVO_DRIVE_2_HANDLE_LOCKED_OUT	Drive 2 will not allow the handle to be operated as required	Drive 2	100%

<b>FSC</b>	<b>Name</b>	<b>Description</b>	<b>FRU Name</b>	<b>Confidence %</b>
268A	FSC_SERVO_DRIVE_3_HANDLE_LOCKED_OUT	Drive 3 will not allow the handle to be operated as required	Drive 3	100%
268B	FSC_SERVO_DRIVE_4_HANDLE_LOCKED_OUT	Drive 4 will not allow the handle to be operated as required	Drive 4	100%
268C	FSC_SERVO_DRIVE_5_HANDLE_LOCKED_OUT	Drive 5 will not allow the handle to be operated as required	Drive 5	100%
268D	FSC_SERVO_DRIVE_6_HANDLE_LOCKED_OUT	Drive 6 will not allow the handle to be operated as required	Drive 6	100%
268E	FSC_SERVO_DRIVE_7_HANDLE_LOCKED_OUT	Drive 7 will not allow the handle to be operated as required	Drive 7	100%
268F	FSC_SERVO_DRIVE_8_HANDLE_LOCKED_OUT	Drive 8 will not allow the handle to be operated as required	Drive 8	100%
2690	FSC_SERVO_DRIVE_1_HANDLE_FAILED_TO_CLOSE	Drive 1 handle failed to close	Drive 1	100%
2691	FSC_SERVO_DRIVE_2_HANDLE_FAILED_TO_CLOSE	Drive 2 handle failed to close	Drive 2	100%
2692	FSC_SERVO_DRIVE_3_HANDLE_FAILED_TO_CLOSE	Drive 3 handle failed to close	Drive 3	100%
2693	FSC_SERVO_DRIVE_4_HANDLE_FAILED_TO_CLOSE	Drive 4 handle failed to close	Drive 4	100%

<b>FSC</b>	<b>Name</b>	<b>Description</b>	<b>FRU Name</b>	<b>Confidence %</b>
2694	FSC_SERVO_DRIVE_5_HANDLE_FAILED_TO_CLOSE	Drive 5 handle failed to close	Drive 5	100%
2695	FSC_SERVO_DRIVE_6_HANDLE_FAILED_TO_CLOSE	Drive 6 handle failed to close	Drive 6	100%
2696	FSC_SERVO_DRIVE_7_HANDLE_FAILED_TO_CLOSE	Drive 7 handle failed to close	Drive 7	100%
2697	FSC_SERVO_DRIVE_8_HANDLE_FAILED_TO_CLOSE	Drive 8 handle failed to close	Drive 8	100%
2698	FSC_SERVO_DRIVE_1_HANDLE_FAILED_TO_OPEN	Drive 1 handle failed to open	Drive 1	100%
2699	FSC_SERVO_DRIVE_2_HANDLE_FAILED_TO_OPEN	Drive 2 handle failed to open	Drive 2	100%
269A	FSC_SERVO_DRIVE_3_HANDLE_FAILED_TO_OPEN	Drive 3 handle failed to open	Drive 3	100%
269B	FSC_SERVO_DRIVE_4_HANDLE_FAILED_TO_OPEN	Drive 4 handle failed to open	Drive 4	100%
269C	FSC_SERVO_DRIVE_5_HANDLE_FAILED_TO_OPEN	Drive 5 handle failed to open	Drive 5	100%
269D	FSC_SERVO_DRIVE_6_HANDLE_FAILED_TO_OPEN	Drive 6 handle failed to open	Drive 6	100%

<b>FSC</b>	<b>Name</b>	<b>Description</b>	<b>FRU Name</b>	<b>Confidence %</b>
269E	FSC_SERVO_DRIVE_7_HANDLE_FAILED_TO_OPEN	Drive 7 handle failed to open	Drive 7	100%
269F	FSC_SERVO_DRIVE_8_HANDLE_FAILED_TO_OPEN	Drive 8 handle failed to open	Drive 8	100%
26A0	FSC_SERVO_DRIVE_1_IN_FLUX	Drive 1 is indicating 'in flux', i.e. not ready for commands	Drive 1	100%
26A1	FSC_SERVO_DRIVE_2_IN_FLUX	Drive 2 is indicating 'in flux', i.e. not ready for commands	Drive 2	100%
26A2	FSC_SERVO_DRIVE_3_IN_FLUX	Drive 3 is indicating 'in flux', i.e. not ready for commands	Drive 3	100%
26A3	FSC_SERVO_DRIVE_4_IN_FLUX	Drive 4 is indicating 'in flux', i.e. not ready for commands	Drive 4	100%
26A4	FSC_SERVO_DRIVE_5_IN_FLUX	Drive 5 is indicating 'in flux', i.e. not ready for commands	Drive 5	100%
26A5	FSC_SERVO_DRIVE_6_IN_FLUX	Drive 6 is indicating 'in flux', i.e. not ready for commands	Drive 6	100%
26A6	FSC_SERVO_DRIVE_7_IN_FLUX	Drive 7 is indicating 'in flux', i.e. not ready for commands	Drive 7	100%
26A7	FSC_SERVO_DRIVE_8_IN_FLUX	Drive 8 is indicating 'in flux', i.e. not ready for commands	Drive 8	100%



<b>FSC</b>	<b>Name</b>	<b>Description</b>	<b>FRU Name</b>	<b>Confidence %</b>
26A8	FSC_SERVO_DRIVE_1_HANDLE_CLOSED_MISMATCH	Drive 1 is indicating its handle is closed, should have been open	Drive 1 Microcode	50% 50%
26A9	FSC_SERVO_DRIVE_2_HANDLE_CLOSED_MISMATCH	Drive 2 is indicating its handle is closed, should have been open	Drive 2 Microcode	50% 50%
26AA	FSC_SERVO_DRIVE_3_HANDLE_CLOSED_MISMATCH	Drive 3 is indicating its handle is closed, should have been open	Drive 3 Microcode	50% 50%
26AB	FSC_SERVO_DRIVE_4_HANDLE_CLOSED_MISMATCH	Drive 4 is indicating its handle is closed, should have been open	Drive 4 Microcode	50% 50%
26AC	FSC_SERVO_DRIVE_5_HANDLE_CLOSED_MISMATCH	Drive 5 is indicating its handle is closed, should have been open	Drive 5 Microcode	50% 50%
26AD	FSC_SERVO_DRIVE_6_HANDLE_CLOSED_MISMATCH	Drive 6 is indicating its handle is closed, should have been open	Drive 6 Microcode	50% 50%
26AE	FSC_SERVO_DRIVE_7_HANDLE_CLOSED_MISMATCH	Drive 7 is indicating its handle is closed, should have been open	Drive 7 Microcode	50% 50%
26AF	FSC_SERVO_DRIVE_8_HANDLE_CLOSED_MISMATCH	Drive 8 is indicating its handle is closed, should have been open	Drive 8 Microcode	50% 50%
26B0	FSC_SERVO_DRIVE_1_HANDLE_OPEN_MISMATCH	Drive 1 is indicating its handle is open, should have been closed	Drive 1 Microcode	50% 50%
26B1	FSC_SERVO_DRIVE_2_HANDLE_OPEN_MISMATCH	Drive 2 is indicating its handle is open, should have been closed	Drive 2 Microcode	50% 50%

<b>FSC</b>	<b>Name</b>	<b>Description</b>	<b>FRU Name</b>	<b>Confidence %</b>
26B2	FSC_SERVO_DRIVE_3_HANDLE_OPEN_MISMATCH	Drive 3 is indicating its handle is open, should have been closed	Drive 3 Microcode	50% 50%
26B3	FSC_SERVO_DRIVE_4_HANDLE_OPEN_MISMATCH	Drive 4 is indicating its handle is open, should have been closed	Drive 4 Microcode	50% 50%
26B4	FSC_SERVO_DRIVE_5_HANDLE_OPEN_MISMATCH	Drive 5 is indicating its handle is open, should have been closed	Drive 5 Microcode	50% 50%
26B5	FSC_SERVO_DRIVE_6_HANDLE_OPEN_MISMATCH	Drive 6 is indicating its handle is open, should have been closed	Drive 6 Microcode	50% 50%
26B6	FSC_SERVO_DRIVE_7_HANDLE_OPEN_MISMATCH	Drive 7 is indicating its handle is open, should have been closed	Drive 7 Microcode	50% 50%
26B7	FSC_SERVO_DRIVE_8_HANDLE_OPEN_MISMATCH	Drive 8 is indicating its handle is open, should have been closed	Drive 8 Microcode	50% 50%
26B8	FSC_SERVO_DRIVE_1_HAS_NO_CARTRIDGE	Drive 1 has no cartridge to unload	Drive 1 Microcode	50% 50%
26B9	FSC_SERVO_DRIVE_2_HAS_NO_CARTRIDGE	Drive 2 has no cartridge to unload	Drive 2 Microcode	50% 50%
26BA	FSC_SERVO_DRIVE_3_HAS_NO_CARTRIDGE	Drive 3 has no cartridge to unload	Drive 3 Microcode	50% 50%
26BB	FSC_SERVO_DRIVE_4_HAS_NO_CARTRIDGE	Drive 4 has no cartridge to unload	Drive 4 Microcode	50% 50%
26BC	FSC_SERVO_DRIVE_5_HAS_NO_CARTRIDGE	Drive 5 has no cartridge to unload	Drive 5 Microcode	50% 50%

<b>FSC</b>	<b>Name</b>	<b>Description</b>	<b>FRU Name</b>	<b>Confidence %</b>
26BD	FSC_SERVO_DRIVE_6_ HAS_NO_CARTRIDGE	Drive 6 has no cartridge to unload	Drive 6 Microcode	50% 50%
26BE	FSC_SERVO_DRIVE_7_ HAS_NO_CARTRIDGE	Drive 7 has no cartridge to unload	Drive 7 Microcode	50% 50%
26BF	FSC_SERVO_DRIVE_8_ HAS_NO_CARTRIDGE	Drive 8 has no cartridge to unload	Drive 8 Microcode	50% 50%
26C0	FSC_SERVO_DRIVE_1_ HAS_NOT_ RESPONDED_TO_ UNLOAD	Drive 1 has not responded to multiple requests to unload	Drive 1 Microcode	50% 50%
26C1	FSC_SERVO_DRIVE_2_ HAS_NOT_ RESPONDED_TO_ UNLOAD	Drive 2 has not responded to multiple requests to unload	Drive 2 Microcode	50% 50%
26C2	FSC_SERVO_DRIVE_3_ HAS_NOT_ RESPONDED_TO_ UNLOAD	Drive 3 has not responded to multiple requests to unload	Drive 3 Microcode	50% 50%
26C3	FSC_SERVO_DRIVE_4_ HAS_NOT_ RESPONDED_TO_ UNLOAD	Drive 4 has not responded to multiple requests to unload	Drive 4 Microcode	50% 50%
26C4	FSC_SERVO_DRIVE_5_ HAS_NOT_ RESPONDED_TO_ UNLOAD	Drive 5 has not responded to multiple requests to unload	Drive 5 Microcode	50% 50%
26C5	FSC_SERVO_DRIVE_6_ HAS_NOT_ RESPONDED_TO_ UNLOAD	Drive 6 has not responded to multiple requests to unload	Drive 6 Microcode	50% 50%

<b>FSC</b>	<b>Name</b>	<b>Description</b>	<b>FRU Name</b>	<b>Confidence %</b>
26C6	FSC_SERVO_DRIVE_7_ HAS_NOT_ RESPONDED_TO_ UNLOAD	Drive 7 has not responded to multiple requests to unload	Drive 7 Microcode	50% 50%
26C7	FSC_SERVO_DRIVE_8_ HAS_NOT_ RESPONDED_TO_ UNLOAD	Drive 8 has not responded to multiple requests to unload	Drive 8 Microcode	50% 50%
26C8	FSC_SERVO_DRIVE_1_ HAS_REJECTED_THE_ CARTRIDGE	Drive 1 has rejected the cartridge, cannot be loaded	Drive 1 Microcode	50% 50%
26C9	FSC_SERVO_DRIVE_2_ HAS_REJECTED_THE_ CARTRIDGE	Drive 2 has rejected the cartridge, cannot be loaded	Drive 2 Microcode	50% 50%
26CA	FSC_SERVO_DRIVE_3_ HAS_REJECTED_THE_ CARTRIDGE	Drive 3 has rejected the cartridge, cannot be loaded	Drive 3 Microcode	50% 50%
26CB	FSC_SERVO_DRIVE_4_ HAS_REJECTED_THE_ CARTRIDGE	Drive 4 has rejected the cartridge, cannot be loaded	Drive 4 Microcode	50% 50%
26CC	FSC_SERVO_DRIVE_5_ HAS_REJECTED_THE_ CARTRIDGE	Drive 5 has rejected the cartridge, cannot be loaded	Drive 5 Microcode	50% 50%
26CD	FSC_SERVO_DRIVE_6_ HAS_REJECTED_THE_ CARTRIDGE	Drive 6 has rejected the cartridge, cannot be loaded	Drive 6 Microcode	50% 50%
26CE	FSC_SERVO_DRIVE_7_ HAS_REJECTED_THE_ CARTRIDGE	Drive 7 has rejected the cartridge, cannot be loaded	Drive 7 Microcode	50% 50%
26CF	FSC_SERVO_DRIVE_8_ HAS_REJECTED_THE_ CARTRIDGE	Drive 8 has rejected the cartridge, cannot be loaded	Drive 8 Microcode	50% 50%

<b>FSC</b>	<b>Name</b>	<b>Description</b>	<b>FRU Name</b>	<b>Confidence %</b>
26D0	FSC_SERVO_DRIVE_1_ HAS_FAILED_TO_LOAD	Drive 1 has failed to load the tape successfully	Drive 1 Microcode	50% 50%
26D1	FSC_SERVO_DRIVE_2_ HAS_FAILED_TO_LOAD	Drive 2 has failed to load the tape successfully	Drive 2 Microcode	50% 50%
26D2	FSC_SERVO_DRIVE_3_ HAS_FAILED_TO_LOAD	Drive 3 has failed to load the tape successfully	Drive 3 Microcode	50% 50%
26D3	FSC_SERVO_DRIVE_4_ HAS_FAILED_TO_LOAD	Drive 4 has failed to load the tape successfully	Drive 4 Microcode	50% 50%
26D4	FSC_SERVO_DRIVE_5_ HAS_FAILED_TO_LOAD	Drive 5 has failed to load the tape successfully	Drive 5 Microcode	50% 50%
26D5	FSC_SERVO_DRIVE_6_ HAS_FAILED_TO_LOAD	Drive 6 has failed to load the tape successfully	Drive 6 Microcode	50% 50%
26D6	FSC_SERVO_DRIVE_7_ HAS_FAILED_TO_LOAD	Drive 7 has failed to load the tape successfully	Drive 7 Microcode	50% 50%
26D7	FSC_SERVO_DRIVE_8_ HAS_FAILED_TO_LOAD	Drive 8 has failed to load the tape successfully	Drive 8 Microcode	50% 50%
26D8	FSC_SERVO_DRIVE_1_ ACCESSED_WHEN_ NOT_FITTED	Attempt to initialize Drive 1 before it has become available	Drive 1 Microcode	50% 50%
26D9	FSC_SERVO_DRIVE_2_ ACCESSED_WHEN_ NOT_FITTED	Attempt to initialize Drive 2 before it has become available	Drive 2 Microcode	50% 50%

<b>FSC</b>	<b>Name</b>	<b>Description</b>	<b>FRU Name</b>	<b>Confidence %</b>
26DA	FSC_SERVO_DRIVE_3_ ACCESSED_WHEN_ NOT_FITTED	Attempt to initialize Drive 3 before it has become available	Drive 3  Microcode	50%  50%
26DB	FSC_SERVO_DRIVE_4_ ACCESSED_WHEN_ NOT_FITTED	Attempt to initialize Drive 4 before it has become available	Drive 4  Microcode	50%  50%
26DC	FSC_SERVO_DRIVE_5_ ACCESSED_WHEN_ NOT_FITTED	Attempt to initialize Drive 5 before it has become available	Drive 5  Microcode	50%  50%
26DD	FSC_SERVO_DRIVE_6_ ACCESSED_WHEN_ NOT_FITTED	Attempt to initialize Drive 6 before it has become available	Drive 6  Microcode	50%  50%
26DE	FSC_SERVO_DRIVE_7_ ACCESSED_WHEN_ NOT_FITTED	Attempt to initialize Drive 7 before it has become available	Drive 7  Microcode	50%  50%
26DF	FSC_SERVO_DRIVE_8_ ACCESSED_WHEN_ NOT_FITTED	Attempt to initialize Drive 8 before it has become available	Drive 8  Microcode	50%  50%
2700	FSC_DIAG_NO_ RESOURCE	PCDIAG task initialization failed	Microcode	100%
2701	FSC_DIAG_BAD_ MESSAGE	Unknown or bad diagnostic message		
2702	FSC_DIAG_STACK_ TERMINATED	Current diagnostic stack has terminated		
2703	FSC_DIAG_QUEUE_ FULL	PCDIAG queue full	Microcode	100%
2704	FSC_DIAG_EMPTY_ INITIATOR_LIST	Diagnostic command failure; initiator task unknown	Microcode	100%
2800	FSC_EVENT_NO_ RESOURCE	EVENT LOG task initialization failed	Microcode	100%

<b>FSC</b>	<b>Name</b>	<b>Description</b>	<b>FRU Name</b>	<b>Confidence %</b>
2801	FSC_EVENT_NVR_TOO_SMALL	NVR space allocated to event log is too small. See path for required space and change in system.	Microcode	100%
2802	FSC_EVENT_BAD_RETRY_LEVEL	Event logger received bad retry level definition	Microcode	100%
2803	FSC_EVENT_BAD_MAGIC	Magic number in event log is bad (log corrupted?)	Microcode	100%
2900	FSC_STACK_CONTROL_NO_RESOURCE	Stack Controller task initialization failed	Microcode	100%
2901	FSC_STACK_CONTROL_QUEUE_FULL	Stack Controller queue is full	Microcode	100%
2902	FSC_STACK_CONTROL_BAD_MESSAGE	Stack Controller task received an unknown or unexpected message		
2A00	FSC_SHUTTLE_QUEUE_FULL	Shuttle queue is full	Microcode	100%
4000	INFO_SCSI_INVALID_LUN	SCSI command received for invalid LUN	Status only	100%
4001	INFO_SCSI_UNKNOWN_ASC	An ASC/ASCQ was used without updating error log logging	Status only	100%
4002	INFO_SCSI_ILLEGAL_COMMAND	Illegal SCSI command received	Status only	100%
4003	INFO_SCSI_TARGET_BUSY	Command received, but library is busy	Status only	100%

<b>FSC</b>	<b>Name</b>	<b>Description</b>	<b>FRU Name</b>	<b>Confidence %</b>
4004	INFO_SCSI_DEFERRED_ERROR	Deferred error is pending	Status only	100%
4005	INFO_SCSI_ATTENTION_RESET	Unit attention - due to reset	Status only	100%
4006	INFO_SCSI_ATTENTION_MODE_PARMS	Unit attention - due to mode parameters changed	Status only	100%
4007	INFO_SCSI_ATTENTION_MEDIUM_CHANGE	Unit attention - due to medium changed	Status only	100%
4008	INFO_SCSI_INVALID_FIELD_IN_CDB	SCSI command had invalid field in CDB	Status only	100%
4009	INFO_SCSI_PARAMETER_LIST_LENGTH_ERROR	SCSI command had parameter list length error	Status only	100%
400A	INFO_SCSI_INVALID_FIELD_IN_PARAMETER_LIST	SCSI command had invalid field in parameter list	Status only	100%
400B	INFO_SCSI_PARAMETER_VALUE_INVALID	SCSI command had invalid parameter value	Status only	100%
400C	INFO_SCSI_MECHANICAL_ERROR	SCSI command failed due to servo problem	Status only	100%
400D	INFO_SCSI_NO_SENSE	No sense available	Status only	100%
400E	INFO_SCSI_CLEANER_CARTRIDGE	Cleaner cartridge fitted	Status only	100%
400F	INFO_SCSI_MEDIUM_DESTINATION_ELEMENT_FULL	Move medium destination full	Status only	100%



<b>FSC</b>	<b>Name</b>	<b>Description</b>	<b>FRU Name</b>	<b>Confidence %</b>
4010	INFO_SCSI_MEDIUM_SOURCE_ELEMENT_EMPTY	Move medium source empty	Status only	100%
4011	INFO_SCSI_SAVING_PARAMETERS_NOT_SUPPORTED	Saving parameters is not supported	Status only	100%
4012	INFO_SCSI_BAD_ELEMENT	Illegal element number	Status only	100%
4013	INFO_SCSI_CARTRIDGE_IN_HAND	Can't complete command while cartridge in hand	Status only	100%
4014	INFO_SCSI_LOGICAL_UNIT_HAS_NOT_SELF_CONFIGURED_YET	Power on configuration not yet finished	Status only	100%
4015	INFO_SCSI_LOGICAL_UNIT_IS_IN_PROCESS_OF_BECOMING_READY	Library will be ready soon, check back later	Status only	100%
4016	INFO_SCSI_LOGICAL_UNIT_NOT_READY_CAUSE_NOT_REPORTABLE	Library not ready, reason unknown	Status only	100%
4017	INFO_SCSI_DOOR_OPEN	Door is open	Status only	100%
4018	INFO_SCSI_IMPORT_EXPORT_OPEN	Import export is open	Status only	100%
4019	INFO_SCSI_IN_MENU	Operator panel is in menu mode	Status only	100%
401A	INFO_SCSI_IMPORT_OR_EXPORT_ELEMENT_ACCESSED	Import/export has been accessed	Status only	100%

<b>FSC</b>	<b>Name</b>	<b>Description</b>	<b>FRU Name</b>	<b>Confidence %</b>
401B	INFO_SCSI_RESERVATION_CONFLICT	Command failed due to reservation conflict	Status only	100%
401C	INFO_SCSI_BUS_RESET	SCSI bus reset received	Status only	100%
401D	INFO_SCSI_BUS_DEVICE_RESET	SCSI bus device reset message received	Status only	100%
401E	INFO_SCSI_ABORT	SCSI abort message received	Status only	100%
401F	INFO_SCSI_MESSAGE_PARITY_ERROR	SCSI message parity error received	Status only	100%
4020	INFO_SCSI_INITIATOR_DETECTED_ERROR	SCSI initiator detected error received	Status only	100%
4100	INFO_PCDIAG_TIME_SET	Time was set via serial port	Status only	100%
4101	INFO_PCDIAG_REMOTE_TIME_SYNC	Time set via synchronization command	Status only	100%
4102	INFO_PCDIAG_TIME_SYNC	Synchronize clock command issued	Status only	100%
4103	INFO_PCDIAG_REBOOT	Library is rebooting	Status only	100%
4104	INFO_PCDIAG_ENTER_BOOT	Library entering boot mode	Status only	100%
4105	INFO_PCDIAG_STARTED	Library has just started	Status only	100%
4106	INFO_PCDIAG_REMOTE_ACK_TIMEOUT	Time out waiting for remote ACK	Status only	100%

<b>FSC</b>	<b>Name</b>	<b>Description</b>	<b>FRU Name</b>	<b>Confidence %</b>
4107	INFO_PCDIAG_REMOTE_RESPONSE_TIMEOUT	Time out waiting for remote RESPONSE	Status only	100%
4108	INFO_PCDIAG_RECVD_REMOTE_TIMEOUT	Remote machine sent time out message	Status only	100%
4200	INFO_SYSTEM_NVR_CORRUPT	NVR CRC invalid, contents probably corrupt	Status only	100%
4400	INFO_LIBRARIAN_ROBOT_PAUSED	Robot paused for operator safety (robotics accessible by operator)	Status only	100%
4401	INFO_LIBRARIAN_DOOR_1_OPEN	Door 1 open (left door)	Status only	100%
4402	INFO_LIBRARIAN_DOOR_2_OPEN	Door 2 open (right door)	Status only	100%
4403	INFO_LIBRARIAN_DOOR_3_OPEN	Door 3 open	Status only	100%
4404	INFO_LIBRARIAN_DOOR_4_OPEN	Door 4 open	Status only	100%
4405	INFO_LIBRARIAN_DOOR_1_CLOSED	Door 1 closed (left door)	Status only	100%
4406	INFO_LIBRARIAN_DOOR_2_CLOSED	Door 2 closed (right door)	Status only	100%
4407	INFO_LIBRARIAN_DOOR_3_CLOSED	Door 3 closed	Status only	100%
4408	INFO_LIBRARIAN_DOOR_4_CLOSED	Door 4 closed	Status only	100%

<b>FSC</b>	<b>Name</b>	<b>Description</b>	<b>FRU Name</b>	<b>Confidence %</b>
4409	INFO_LIBRARIAN_MAG_1_REMOVED	Magazine 1 has been removed (left magazine)	Status only	100%
440A	INFO_LIBRARIAN_MAG_2_REMOVED	Magazine 2 has been removed (right magazine)	Status only	100%
440B	INFO_LIBRARIAN_MAG_3_REMOVED	Magazine 3 has been removed (left magazine)	Status only	100%
440C	INFO_LIBRARIAN_MAG_4_REMOVED	Magazine 4 has been removed (right magazine)	Status only	100%
440D	INFO_LIBRARIAN_MAG_5_REMOVED	Magazine 5 has been removed (left magazine)	Status only	100%
440E	INFO_LIBRARIAN_MAG_6_REMOVED	Magazine 6 has been removed (right magazine)	Status only	100%
440F	INFO_LIBRARIAN_MAG_7_REMOVED	Magazine 7 has been removed (left magazine)	Status only	100%
4410	INFO_LIBRARIAN_MAG_8_REMOVED	Magazine 8 has been removed (right magazine)	Status only	100%
4411	INFO_LIBRARIAN_MAG_9_REMOVED	Magazine 9 has been removed (left magazine)	Status only	100%
4412	INFO_LIBRARIAN_MAG_10_REMOVED	Magazine 10 has been removed (right magazine)	Status only	100%

<b>FSC</b>	<b>Name</b>	<b>Description</b>	<b>FRU Name</b>	<b>Confidence %</b>
4413	INFO_LIBRARIAN_MAG_1_INSERTED	Magazine 1 has been inserted (left magazine)	Status only	100%
4414	INFO_LIBRARIAN_MAG_2_INSERTED	Magazine 2 has been inserted (right magazine)	Status only	100%
4415	INFO_LIBRARIAN_MAG_3_INSERTED	Magazine 3 has been inserted (left magazine)	Status only	100%
4416	INFO_LIBRARIAN_MAG_4_INSERTED	Magazine 4 has been inserted (left magazine)	Status only	100%
4417	INFO_LIBRARIAN_MAG_5_INSERTED	Magazine 5 has been inserted (left magazine)	Status only	100%
4418	INFO_LIBRARIAN_MAG_6_INSERTED	Magazine 6 has been inserted (left magazine)	Status only	100%
4419	INFO_LIBRARIAN_MAG_7_INSERTED	Magazine 7 has been inserted (left magazine)	Status only	100%
441A	INFO_LIBRARIAN_MAG_8_INSERTED	Magazine 8 has been inserted (left magazine)	Status only	100%
441B	INFO_LIBRARIAN_MAG_9_INSERTED	Magazine 9 has been inserted (left magazine)	Status only	100%
441C	INFO_LIBRARIAN_MAG_10_INSERTED	Magazine 10 has been inserted (left magazine)	Status only	100%

Appendix B Fault Symptom Code (FSC) Dictionary

<b>FSC</b>	<b>Name</b>	<b>Description</b>	<b>FRU Name</b>	<b>Confidence %</b>
441D	INFO_LIBRARIAN_MAG_1_ABSENT	Magazine 1 absent at power-up (left magazine)	Status only	100%
441E	INFO_LIBRARIAN_MAG_2_ABSENT	Magazine 2 absent at power-up (right magazine)	Status only	100%
441F	INFO_LIBRARIAN_MAG_3_ABSENT	Magazine 3 absent at power-up (left magazine)	Status only	100%
4420	INFO_LIBRARIAN_MAG_4_ABSENT	Magazine 4 absent at power-up (left magazine)	Status only	100%
4421	INFO_LIBRARIAN_MAG_5_ABSENT	Magazine 5 absent at power-up (left magazine)	Status only	100%
4422	INFO_LIBRARIAN_MAG_6_ABSENT	Magazine 6 absent at power-up (left magazine)	Status only	100%
4423	INFO_LIBRARIAN_MAG_7_ABSENT	Magazine 7 absent at power-up (left magazine)	Status only	100%
4424	INFO_LIBRARIAN_MAG_8_ABSENT	Magazine 8 absent at power-up (left magazine)	Status only	100%
4425	INFO_LIBRARIAN_MAG_9_ABSENT	Magazine 9 absent at power-up (left magazine)	Status only	100%
4426	INFO_LIBRARIAN_MAG_10_ABSENT	Magazine 10 absent at power-up (left magazine)	Status only	100%
4427	INFO_LIBRARIAN_READY	Library Ready	Status only	100%

<b>FSC</b>	<b>Name</b>	<b>Description</b>	<b>FRU Name</b>	<b>Confidence %</b>
4428	INFO_LIBRARIAN_NOT_READY	Library Not-Ready	Status only	100%
4429	INFO_LIBRARIAN_DRIVE_1_REMOVED	Drive 1 removed	Status only	100%
442A	INFO_LIBRARIAN_DRIVE_2_REMOVED	Drive 2 removed	Status only	100%
442B	INFO_LIBRARIAN_DRIVE_3_REMOVED	Drive 3 removed	Status only	100%
442C	INFO_LIBRARIAN_DRIVE_4_REMOVED	Drive 4 removed	Status only	100%
442D	INFO_LIBRARIAN_DRIVE_5_REMOVED	Drive 5 removed	Status only	100%
442E	INFO_LIBRARIAN_DRIVE_6_REMOVED	Drive 6 removed	Status only	100%
442F	INFO_LIBRARIAN_DRIVE_7_REMOVED	Drive 7 removed	Status only	100%
4430	INFO_LIBRARIAN_DRIVE_8_REMOVED	Drive 8 removed	Status only	100%
4434	INFO_LIBRARIAN_DRIVE_1_INSERTED	Drive 1 inserted	Status only	100%
4435	INFO_LIBRARIAN_DRIVE_2_INSERTED	Drive 2 inserted	Status only	100%
4436	INFO_LIBRARIAN_DRIVE_3_INSERTED	Drive 3 inserted	Status only	100%
4437	INFO_LIBRARIAN_DRIVE_4_INSERTED	Drive 4 inserted	Status only	100%
4438	INFO_LIBRARIAN_DRIVE_5_INSERTED	Drive 5 inserted	Status only	100%

Appendix B Fault Symptom Code (FSC) Dictionary

<b>FSC</b>	<b>Name</b>	<b>Description</b>	<b>FRU Name</b>	<b>Confidence %</b>
4439	INFO_LIBRARIAN_DRIVE_6_INSERTED	Drive 6 inserted	Status only	100%
443A	INFO_LIBRARIAN_DRIVE_7_INSERTED	Drive 7 inserted	Status only	100%
443B	INFO_LIBRARIAN_DRIVE_8_INSERTED	Drive 8 inserted	Status only	100%
443E	INFO_LIBRARIAN_DRIVE_1_ABSENT	Drive 1 absent at power-on	Status only	100%
443F	INFO_LIBRARIAN_DRIVE_2_ABSENT	Drive 2 absent at power-on	Status only	100%
4440	INFO_LIBRARIAN_DRIVE_3_ABSENT	Drive 3 absent at power-on	Status only	100%
4441	INFO_LIBRARIAN_DRIVE_4_ABSENT	Drive 4 absent at power-on	Status only	100%
4442	INFO_LIBRARIAN_DRIVE_5_ABSENT	Drive 5 absent at power-on	Status only	100%
4443	INFO_LIBRARIAN_DRIVE_6_ABSENT	Drive 6 absent at power-on	Status only	100%
4444	INFO_LIBRARIAN_DRIVE_7_ABSENT	Drive 7 absent at power-on	Status only	100%
4445	INFO_LIBRARIAN_DRIVE_8_ABSENT	Drive 8 absent at power-on	Status only	100%
4448	INFO_LIBRARIAN_DRIVE_1_ON	Drive 1 has powered up	Status only	100%
4449	INFO_LIBRARIAN_DRIVE_2_ON	Drive 2 has powered up	Status only	100%
444A	INFO_LIBRARIAN_DRIVE_3_ON	Drive 3 has powered up	Status only	100%



<b>FSC</b>	<b>Name</b>	<b>Description</b>	<b>FRU Name</b>	<b>Confidence %</b>
444B	INFO_LIBRARIAN_DRIVE_4_ON	Drive 4 has powered up	Status only	100%
444C	INFO_LIBRARIAN_DRIVE_5_ON	Drive 5 has powered up	Status only	100%
444D	INFO_LIBRARIAN_DRIVE_6_ON	Drive 6 has powered up	Status only	100%
444E	INFO_LIBRARIAN_DRIVE_7_ON	Drive 7 has powered up	Status only	100%
444F	INFO_LIBRARIAN_DRIVE_8_ON	Drive 8 has powered up	Status only	100%
4452	INFO_LIBRARIAN_DRIVE_1_OFF	Drive 1 has powered down	Status only	100%
4453	INFO_LIBRARIAN_DRIVE_2_OFF	Drive 2 has powered down	Status only	100%
4454	INFO_LIBRARIAN_DRIVE_3_OFF	Drive 3 has powered down	Status only	100%
4455	INFO_LIBRARIAN_DRIVE_4_OFF	Drive 4 has powered down	Status only	100%
4456	INFO_LIBRARIAN_DRIVE_5_OFF	Drive 5 has powered down	Status only	100%
4457	INFO_LIBRARIAN_DRIVE_6_OFF	Drive 6 has powered down	Status only	100%
4458	INFO_LIBRARIAN_DRIVE_7_OFF	Drive 7 has powered down	Status only	100%
4459	INFO_LIBRARIAN_DRIVE_8_OFF	Drive 8 has powered down	Status only	100%
445C	INFO_LIBRARIAN_DRIVE_1_AUTO_CLEAN_REQ	Drive 1 requesting auto-clean	Status only	100%

<b>FSC</b>	<b>Name</b>	<b>Description</b>	<b>FRU Name</b>	<b>Confidence %</b>
445D	INFO_LIBRARIAN_ DRIVE_2_AUTO_ CLEAN_REQ	Drive 2 requesting auto-clean	Status only	100%
445E	INFO_LIBRARIAN_ DRIVE_3_AUTO_ CLEAN_REQ	Drive 3 requesting auto-clean	Status only	100%
445F	INFO_LIBRARIAN_ DRIVE_4_AUTO_ CLEAN_REQ	Drive 4 requesting auto-clean	Status only	100%
4460	INFO_LIBRARIAN_ DRIVE_5_AUTO_ CLEAN_REQ	Drive 5 requesting auto-clean	Status only	100%
4461	INFO_LIBRARIAN_ DRIVE_6_AUTO_ CLEAN_REQ	Drive 6 requesting auto-clean	Status only	100%
4462	INFO_LIBRARIAN_ DRIVE_7_AUTO_ CLEAN_REQ	Drive 7 requesting auto-clean	Status only	100%
4463	INFO_LIBRARIAN_ DRIVE_8_AUTO_ CLEAN_REQ	Drive 8 requesting auto-clean	Status only	100%
4466	INFO_LIBRARIAN_ CLEAN_DRIVE_1	Cleaning cycle started on Drive 1	Status only	100%
4467	INFO_LIBRARIAN_ CLEAN_DRIVE_2	Cleaning cycle started on Drive 2	Status only	100%
4468	INFO_LIBRARIAN_ CLEAN_DRIVE_3	Cleaning cycle started on Drive 3	Status only	100%
4469	INFO_LIBRARIAN_ CLEAN_DRIVE_4	Cleaning cycle started on Drive 4	Status only	100%
446A	INFO_LIBRARIAN_ CLEAN_DRIVE_5	Cleaning cycle started on Drive 5	Status only	100%

<b>FSC</b>	<b>Name</b>	<b>Description</b>	<b>FRU Name</b>	<b>Confidence %</b>
446B	INFO_LIBRARIAN_CLEAN_DRIVE_6	Cleaning cycle started on Drive 6	Status only	100%
446C	INFO_LIBRARIAN_CLEAN_DRIVE_7	Cleaning cycle started on Drive 7	Status only	100%
446D	INFO_LIBRARIAN_CLEAN_DRIVE_8	Cleaning cycle started on Drive 8	Status only	100%
4470	INFO_LIBRARIAN_CLEANING_TAPE_EXPIRED	Cleaning tape expired	Status only	100%
4471	INFO_LIBRARIAN_NOT_CLEANING_TAPE	Drive clean attempted with a non-cleaning tape	Status only	100%
4472	INFO_LIBRARIAN_DRIVE_1_CLEAN_COMPLETE	Drive 1 has been cleaned successfully	Status only	100%
4473	INFO_LIBRARIAN_DRIVE_2_CLEAN_COMPLETE	Drive 2 has been cleaned successfully	Status only	100%
4474	INFO_LIBRARIAN_DRIVE_3_CLEAN_COMPLETE	Drive 3 has been cleaned successfully	Status only	100%
4475	INFO_LIBRARIAN_DRIVE_4_CLEAN_COMPLETE	Drive 4 has been cleaned successfully	Status only	100%
4476	INFO_LIBRARIAN_DRIVE_5_CLEAN_COMPLETE	Drive 5 has been cleaned successfully	Status only	100%
4477	INFO_LIBRARIAN_DRIVE_6_CLEAN_COMPLETE	Drive 6 has been cleaned successfully	Status only	100%

<b>FSC</b>	<b>Name</b>	<b>Description</b>	<b>FRU Name</b>	<b>Confidence %</b>
4478	INFO_LIBRARIAN_ DRIVE_7_CLEAN_ COMPLETE	Drive 7 has been cleaned successfully	Status only	100%
4479	INFO_LIBRARIAN_ DRIVE_8_CLEAN_ COMPLETE	Drive 8 has been cleaned successfully	Status only	100%
447C	INFO_LIBRARIAN_ DRIVE_1_CLEAN_ UNSUCCESSFUL	Drive 1 is still requesting cleaning after being cleaned	Status only	100%
447D	INFO_LIBRARIAN_ DRIVE_2_CLEAN_ UNSUCCESSFUL	Drive 2 is still requesting cleaning after being cleaned	Status only	100%
447E	INFO_LIBRARIAN_ DRIVE_3_CLEAN_ UNSUCCESSFUL	Drive 3 is still requesting cleaning after being cleaned	Status only	100%
447F	INFO_LIBRARIAN_ DRIVE_4_CLEAN_ UNSUCCESSFUL	Drive 4 is still requesting cleaning after being cleaned	Status only	100%
4480	INFO_LIBRARIAN_ DRIVE_5_CLEAN_ UNSUCCESSFUL	Drive 5 is still requesting cleaning after being cleaned	Status only	100%
4481	INFO_LIBRARIAN_ DRIVE_6_CLEAN_ UNSUCCESSFUL	Drive 6 is still requesting cleaning after being cleaned	Status only	100%
4482	INFO_LIBRARIAN_ DRIVE_7_CLEAN_ UNSUCCESSFUL	Drive 7 is still requesting cleaning after being cleaned	Status only	100%
4483	INFO_LIBRARIAN_ DRIVE_8_CLEAN_ UNSUCCESSFUL	Drive 8 is still requesting cleaning after being cleaned	Status only	100%

<b>FSC</b>	<b>Name</b>	<b>Description</b>	<b>FRU Name</b>	<b>Confidence %</b>
4486	INFO_LIBRARIAN_LEVEL_1_REMOVED	Module at level 1 in stack has been powered down/disconnected	Status only	100%
4487	INFO_LIBRARIAN_LEVEL_2_REMOVED	Module at level 2 in stack has been powered down/disconnected	Status only	100%
4488	INFO_LIBRARIAN_LEVEL_3_REMOVED	Module at level 3 in stack has been powered down/disconnected	Status only	100%
4489	INFO_LIBRARIAN_LEVEL_4_REMOVED	Module at level 4 in stack has been powered down/disconnected	Status only	100%
448A	INFO_LIBRARIAN_LEVEL_5_REMOVED	Module at level 5 in stack has been powered down/disconnected	Status only	100%
448B	INFO_LIBRARIAN_LEVEL_6_REMOVED	Module at level 6 in stack has been powered down/disconnected	Status only	100%
448C	INFO_LIBRARIAN_LEVEL_7_REMOVED	Module at level 7 in stack has been powered down/disconnected	Status only	100%
448D	INFO_LIBRARIAN_LEVEL_8_REMOVED	Module at level 8 in stack has been powered down/disconnected	Status only	100%

Appendix B Fault Symptom Code (FSC) Dictionary

<b>FSC</b>	<b>Name</b>	<b>Description</b>	<b>FRU Name</b>	<b>Confidence %</b>
448E	INFO_LIBRARIAN_LEVEL_9_REMOVED	Module at level 9 in stack has been powered down/disconnected	Status only	100%
448F	INFO_LIBRARIAN_LEVEL_10_REMOVED	Module at level 10 in stack has been powered down/disconnected	Status only	100%
4490	INFO_LIBRARIAN_LEVEL_11_REMOVED	Module at level 11 in stack has been powered down/disconnected	Status only	100%
4491	INFO_LIBRARIAN_LEVEL_12_REMOVED	Module at level 12 in stack has been powered down/disconnected	Status only	100%
4492	INFO_LIBRARIAN_MODULE_ADDED_TO_STACK	New module has joined stack	Status only	100%
4493	INFO_LIBRARIAN_LEVEL_1_FITTED	Level 1 fitted in stack	Status only	100%
4494	INFO_LIBRARIAN_LEVEL_2_FITTED	Level 2 fitted in stack	Status only	100%
4495	INFO_LIBRARIAN_LEVEL_3_FITTED	Level 3 fitted in stack	Status only	100%
4496	INFO_LIBRARIAN_LEVEL_4_FITTED	Level 4 fitted in stack	Status only	100%
4497	INFO_LIBRARIAN_LEVEL_5_FITTED	Level 5 fitted in stack	Status only	100%
4498	INFO_LIBRARIAN_LEVEL_6_FITTED	Level 6 fitted in stack	Status only	100%

<b>FSC</b>	<b>Name</b>	<b>Description</b>	<b>FRU Name</b>	<b>Confidence %</b>
4499	INFO_LIBRARIAN_LEVEL_7_FITTED	Level 7 fitted in stack	Status only	100%
449A	INFO_LIBRARIAN_LEVEL_8_FITTED	Level 8 fitted in stack	Status only	100%
449B	INFO_LIBRARIAN_LEVEL_9_FITTED	Level 9 fitted in stack	Status only	100%
449C	INFO_LIBRARIAN_LEVEL_10_FITTED	Level 10 fitted in stack	Status only	100%
449D	INFO_LIBRARIAN_LEVEL_11_FITTED	Level 11 fitted in stack	Status only	100%
449E	INFO_LIBRARIAN_LEVEL_12_FITTED	Level 12 fitted in stack	Status only	100%
449F	INFO_LIBRARIAN_LEVEL_1_NOT_FITTED	Level 1 not fitted in stack	Status only	100%
44A0	INFO_LIBRARIAN_LEVEL_2_NOT_FITTED	Level 2 not fitted in stack	Status only	100%
44A1	INFO_LIBRARIAN_LEVEL_3_NOT_FITTED	Level 3 not fitted in stack	Status only	100%
44A2	INFO_LIBRARIAN_LEVEL_4_NOT_FITTED	Level 4 not fitted in stack	Status only	100%
44A3	INFO_LIBRARIAN_LEVEL_5_NOT_FITTED	Level 5 not fitted in stack	Status only	100%
44A4	INFO_LIBRARIAN_LEVEL_6_NOT_FITTED	Level 6 not fitted in stack	Status only	100%
44A5	INFO_LIBRARIAN_LEVEL_7_NOT_FITTED	Level 7 not fitted in stack	Status only	100%
44A6	INFO_LIBRARIAN_LEVEL_8_NOT_FITTED	Level 8 not fitted in stack	Status only	100%

<b>FSC</b>	<b>Name</b>	<b>Description</b>	<b>FRU Name</b>	<b>Confidence %</b>
44A7	INFO_LIBRARIAN_ LEVEL_9_NOT_FITTED	Level 9 not fitted in stack	Status only	100%
44A8	INFO_LIBRARIAN_ LEVEL_10_NOT_FITTED	Level 10 not fitted in stack	Status only	100%
44A9	INFO_LIBRARIAN_ LEVEL_11_NOT_FITTED	Level 11 not fitted in stack	Status only	100%
44AA	INFO_LIBRARIAN_ LEVEL_12_NOT_FITTED	Level 12 not fitted in stack	Status only	100%
44AB	INFO_LIBRARIAN_ DRIVE_1_CUP_ COMPLETE	Code update from tape complete on drive 1	Status only	100%
44AC	INFO_LIBRARIAN_ DRIVE_2_CUP_ COMPLETE	Code update from tape complete on drive 2	Status only	100%
44AD	INFO_LIBRARIAN_ DRIVE_3_CUP_ COMPLETE	Code update from tape complete on drive 3	Status only	100%
44AE	INFO_LIBRARIAN_ DRIVE_4_CUP_ COMPLETE	Code update from tape complete on drive 4	Status only	100%
44AF	INFO_LIBRARIAN_ DRIVE_5_CUP_ COMPLETE	Code update from tape complete on drive 5	Status only	100%
44B0	INFO_LIBRARIAN_ DRIVE_6_CUP_ COMPLETE	Code update from tape complete on drive 6	Status only	100%
44B1	INFO_LIBRARIAN_ DRIVE_7_CUP_ COMPLETE	Code update from tape complete on drive 7	Status only	100%



<b>FSC</b>	<b>Name</b>	<b>Description</b>	<b>FRU Name</b>	<b>Confidence %</b>
44B2	INFO_LIBRARIAN_DRIVE_8_CUP_COMPLETE	Code update from tape complete on drive 8	Status only	100%
44B3	INFO_LIBRARIAN_CUP_DRIVE_1	Initiate code update from tape on drive 1	Status only	100%
44B4	INFO_LIBRARIAN_CUP_DRIVE_2	Initiate code update from tape on drive 2	Status only	100%
44B5	INFO_LIBRARIAN_CUP_DRIVE_3	Initiate code update from tape on drive 3	Status only	100%
44B6	INFO_LIBRARIAN_CUP_DRIVE_4	Initiate code update from tape on drive 4	Status only	100%
44B7	INFO_LIBRARIAN_CUP_DRIVE_5	Initiate code update from tape on drive 5	Status only	100%
44B8	INFO_LIBRARIAN_CUP_DRIVE_6	Initiate code update from tape on drive 6	Status only	100%
44B9	INFO_LIBRARIAN_CUP_DRIVE_7	Initiate code update from tape on drive 7	Status only	100%
44BA	INFO_LIBRARIAN_CUP_DRIVE_8	Initiate code update from tape on drive 8	Status only	100%
44BB	INFO_LIBRARIAN_CUP_NOT_SUPPORTED	Code update not supported for this drive	Status only	100%
44BC	INFO_COMMAND_NOT_SUPPORTED	Command not supported	Status only	100%
4600	FSC_SERVO_POWER_ON_INITIALISATION_COMPLETE	The library's power-on initialization sequence has completed	Status only	100%
4680	FSC_SERVO_DRIVE_1_RELOAD_NECESSARY	Drive 1 has rejected the cartridge, a reload is underway	Drive 1	100%

<b>FSC</b>	<b>Name</b>	<b>Description</b>	<b>FRU Name</b>	<b>Confidence %</b>
4681	FSC_SERVO_DRIVE_2_RELOAD_NECESSARY	Drive 2 has rejected the cartridge, a reload is underway	Drive 2	100%
4682	FSC_SERVO_DRIVE_3_RELOAD_NECESSARY	Drive 3 has rejected the cartridge, a reload is underway	Drive 3	100%
4683	FSC_SERVO_DRIVE_4_RELOAD_NECESSARY	Drive 4 has rejected the cartridge, a reload is underway	Drive 4	100%
4684	FSC_SERVO_DRIVE_5_RELOAD_NECESSARY	Drive 5 has rejected the cartridge, a reload is underway	Drive 5	100%
4685	FSC_SERVO_DRIVE_6_RELOAD_NECESSARY	Drive 6 has rejected the cartridge, a reload is underway	Drive 6	100%
4686	FSC_SERVO_DRIVE_7_RELOAD_NECESSARY	Drive 7 has rejected the cartridge, a reload is underway	Drive 7	100%
4687	FSC_SERVO_DRIVE_8_RELOAD_NECESSARY	Drive 8 has rejected the cartridge, a reload is underway	Drive 8	100%
4900	INFO_STACK_MASTER	This unit has become the stack-master (shuttle controller)	Status only	100%
4901	INFO_STACK_SLAVE	This unit has changed from stack-master to slave module	Status only	100%
4902	INFO_STACK_MASTER_DEAD	The stack-master is no longer polling this unit	Status only	100%

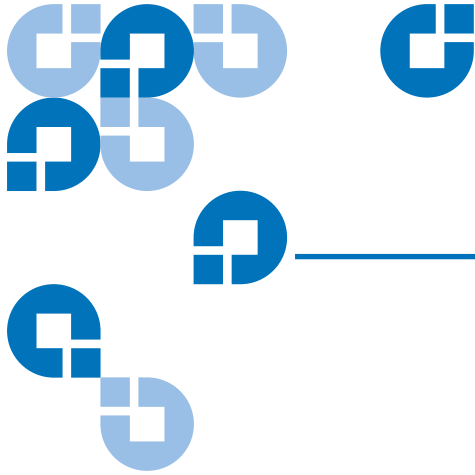

## Appendix C

# DLTtape Cartridge Maintenance

---

This appendix provides guidelines for handling DLT cartridges and visually inspecting cartridges if necessary.

---

## Handling DLTtape Cartridges

- Always keep each tape cartridge in its protective plastic case when it is not in the library.
- When carrying tape cartridges in their cases, always orient the cases so that the grooves in the cases interlock. This prevents the cases from slipping apart and falling.
- Never stack more than five cartridges on top of each other.
- Always observe the proper environmental conditions for the storage of tape cartridges. Refer to the cartridge reference card supplied with each cartridge.
- When placing tape cartridges in archival storage, make sure you stand each tape cartridge vertically.
- Avoid placing tape cartridges near any sources of high intensity magnetic fields, such as computer monitors or electric motors.

- Never apply adhesive labels or POST-IT notes to the top, side, or bottom of your DLTtape cartridge. Only use the user slide-in type label provided with each cartridge and slide it over the label slot on the cartridge.
- Do not carry cartridges loosely in a box or any other container. Allowing cartridges to bang together exposes them to unnecessary physical shock.
- Do not touch or allow direct contact with tape or tape leader. Dust or natural skin oils can contaminate the tape and impact tape performance.
- Do not expose the tape cartridge to moisture or direct sunlight.
- Do not insert a dropped or damaged cartridge into a DLTtape drive without, at the very least, a thorough visual inspection (see [Visual Inspection of DLTtape Cartridges](#)). A dropped cartridge may have dislodged, loosened, or damaged internal components.

---

## Visual Inspection of DLTtape Cartridges

---

### When To Visually Inspect a DLTtape Cartridge

It is important to visually inspect a DLTtape cartridge under the following circumstances:

- Whenever you change or load a new tape cartridge
- If the tape cartridge has been dropped or subjected to a physical shock
- If a DLTtape drive becomes inoperable after loading the tape cartridge
- If you receive a shipment of tape cartridges that shows any sign of being damaged

---

### Visual Inspection Procedure

To visually inspect a DLTtape cartridge:

- 1 Check the cartridge for any obvious cracks or other physical damage.

- 2 Gently shake the tape cartridge. Listen for any rattling of loose pieces inside the cartridge.

**Caution:** If you hear anything loose inside the cartridge, do not use the cartridge.

- 3 Locate the reel lock openings (see [figure 61](#)) and verify that you can see the reel locks.

The reel locks are small plastic tabs near the center of the reel lock openings. They can be broken if the cartridge is dropped.

**Caution:** If the reel locks are not visible, do not use the cartridge.

Figure 61 Location of the Reel Locks and the Hub

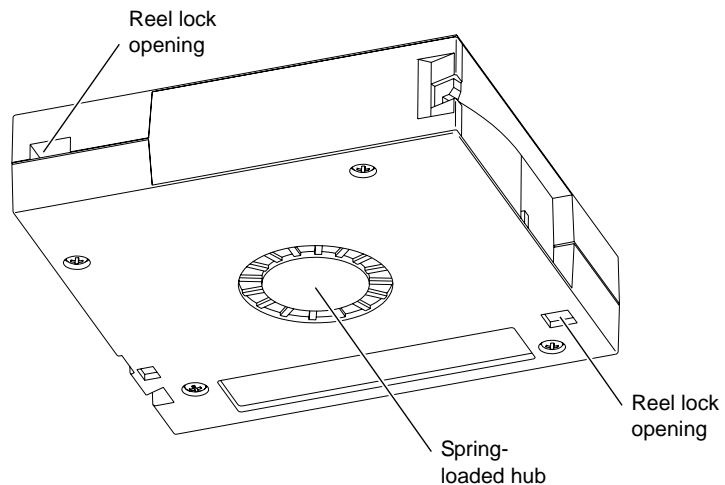

- 4 Verify that the spring-loaded hub (see [figure 61](#)) is centered within the circular opening in the tape cartridge.
- 5 Gently press the hub, then release it. Make sure the hub springs back into place and is still centered within its circular opening.
- 6 Open the tape cartridge door (see [figure 62](#)):
  - a Gently press up on the tab at the right side of the tape cartridge door.

- b Swing the door open.

Figure 62 Opening the Tape Cartridge Door

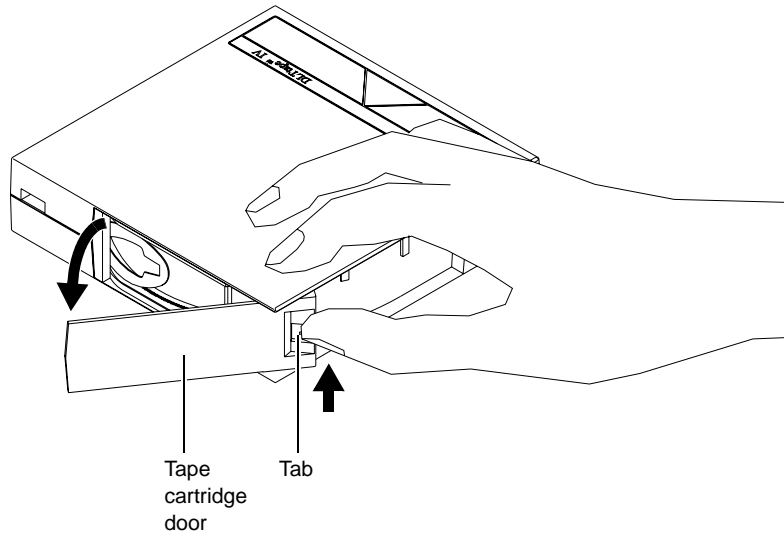

- 7 Verify that:

- The tape is wound tightly on the reel
- The tape leader loop is sticking up about an eighth of an inch
- The tape leader loop is not bent or torn

**Caution:** If any of the above conditions are not met, do not use the cartridge.

- 8 Check for proper operation of the tape cartridge's write-protect switch (see [figure 63](#)).

The switch should snap back and forth, and the orange tab should be visible when the switch is in the write-protected position.

Figure 63 Write  
Protect Switch

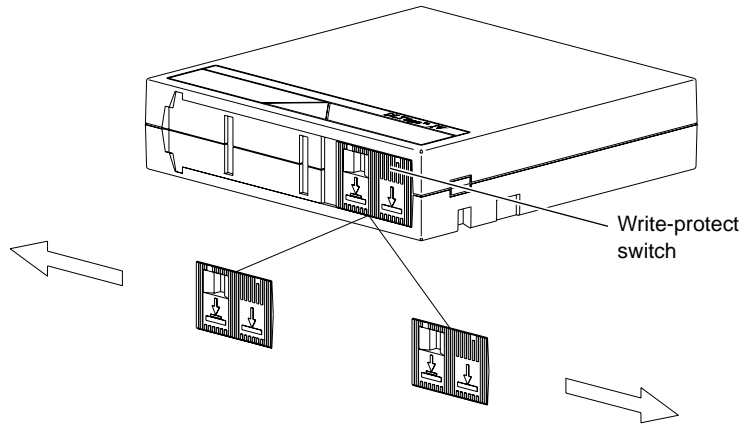

Appendix C DLTtape Cartridge Maintenance  
Visual Inspection of DLTtape Cartridges



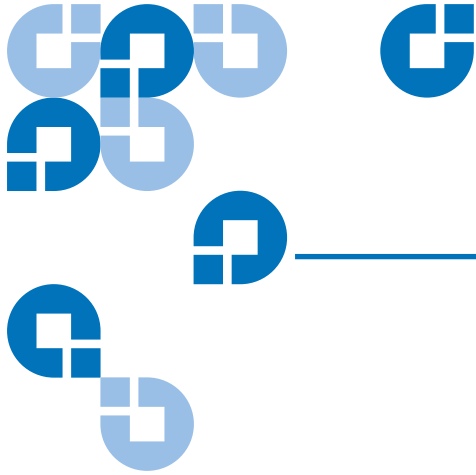

## Appendix D

# Regulatory Statements

---

This appendix provides the regulatory statements for the ATL M-Series libraries, in the following languages:

- English (page [168](#))
- Deutsch (seite [170](#))
- Español (página [173](#))
- Français (page [176](#))
- Italiano (pagina [179](#))
- Svenska (sidan [181](#))
- 简体中文 (Simplified Chinese) ([184](#))
- 繁體中文 (Traditional Chinese) ([187](#))
- 日本語 (Japanese) ([189](#))
- 한국어 (Korean) ([192](#))

---

## English

---

### FCC Statement

This equipment has been tested and found to comply with the limits for a Class A digital device, pursuant to Part 15 of the FCC Rules. These limits are designed to provide reasonable protection against harmful interference when the equipment is operated in a commercial environment. This equipment generates, uses, and can radiate radio frequency energy and, if not installed and used in accordance with the instruction manual, may cause harmful interference to radio communications.

Any changes or modifications made to this equipment may void the user's authority to operate this equipment.

Operation of this equipment in a residential area may cause interference in which case the user at his own expense will be required to take whatever measures may be required to correct the interference.

This device complies with Part 15 of the FCC Rules. Operation is subject to the following conditions:

- 1 This device may not cause harmful interference, and
- 2 This device must accept any interference received, including interference that may cause undesired operation.

---

### Taiwan Statement

警告使用者:

這是甲類的資訊產品，在居住的環境中使用時，可能會造成射頻干擾，在這種情況下，使用者會被要求採取某些適當的對策。

---

## Industry Canada (Digital Apparatus)

**Reference:** *Interference-Causing Equipment Standard, ICES-003, Issue 2*

This Class A digital apparatus meets all requirements of the Canadian Interference-Causing Equipment Regulations.

---

### **CISPR-22 Warning!**

This is a Class A product. In a domestic environment this product may cause radio interference in which case the user may be required to take adequate measures.

---

## Notice for USA and CANADA Only

If shipped to USA, use the UL LISTED power cord specified below for 100-120 V operation. If shipped to Canada, use the CSA CERTIFIED power cord specified below for 100-120V operation.

Plug Cap	Parallel blade with ground pin (NEMA 5-15P configuration)
Cord	Type: SJT, three 16 AWG (1.5 mm <sup>2</sup> ) or 18 AWG (1.0 mm <sup>2</sup> ) wires
Length	Maximum 15 feet (4.5m)
Rating	Minimum 10 A, 125 V

---

## Laser Statement

**CAUTION:** With all panels and enclosures in place, this product is rated as a Class I laser product. The bar code scanner inside this product, however, is a Class II laser. Avoid exposure to the laser light emitted from the bar code scanner. Do not stare into the beam.

**CAUTION:** Use of controls or adjustments or performance of procedures other than those specified herein may result in hazardous exposure.

---

## Library Battery Statement

**CAUTION:** This product contains a Lithium battery. The nonvolatile RAM, Dallas Semiconductor DS1743-100, contains a Lithium battery. Lithium may be considered a hazardous material. Dispose of this battery in accordance with local, state, and federal laws.

---

## MC300 Battery Statement

**CAUTION:** Danger of explosion if battery is incorrectly replaced. Replace only with the same or equivalent type recommended by the manufacturer. Dispose of used batteries according to the manufacturer's instructions.

---

## Deutsch

---

### Regelungen der FCC

Nach Tests wurde festgelegt, dass dieses Gerät den digitalen Geräten der Klasse A entspricht und den Vorschriften in Abschnitt 15 der Regelungen der FCC unterliegt. Durch diese Vorschriften wird ein angemessener Schutz vor schädlichen Strahlungen gewährleistet, wenn dieses Gerät in einer kommerziellen Umgebung betrieben wird. Von den Geräten wird Hochfrequenzenergie erzeugt, genutzt und abgestrahlt, die bei einer im Widerspruch zu diesem Handbuch stehenden Installation oder Nutzung Funkstörungen erzeugen kann.

Änderungen und Modifikationen an diesem Gerät können zum Erlöschen der Betriebserlaubnis für dieses Gerät führen.

Der Betrieb dieses Geräts in Wohngebieten kann zu Empfangsstörungen führen, die der Verursacher auf eigene Kosten beheben muss.

Dieses Gerät erfüllt die Vorschriften in Abschnitt 15 der Regelungen der FCC. Der Betrieb unterliegt den folgenden Bedingungen:

- 1 Das Gerät darf keine schädlichen Störungen hervorrufen und
- 2 Das Gerät muss alle eingehenden Störungen aufnehmen, einschließlich Störungen, die einen unerwünschten Betrieb verursachen können.

---

## Regelungen für Taiwan

警告使用者:

這是甲類的資訊產品，在居住的環境中使用時，可能會造成射頻干擾，在這種情況下，使用者會被要求採取某些適當的對策。

---

## Industry Canada (Digital-Apparate)

**Referenz:** *Norm für störungsverursachende Geräte, ICES-003, Ausgabe 2*

Dieses Digitalgerät der Klasse A erfüllt alle Anforderungen der kanadischen Vorschriften bezüglich störungsverursachender Geräte (Canadian Interference-Causing Equipment Regulations).

---

### **CISPR-22 Warnung!**

Dies ist ein Produkt der Klasse A. Dieses Produkt kann in Wohngedenden Funkstörungen verursachen, die vom Verursacher durch angemessene Maßnahmen behoben werden müssen.

---

## Hinweis nur für USA und KANADA

Wenn dieses Produkt in die USA geliefert wird, muss das nachstehend für einen 100-120-Volt-Betrieb spezifizierte und von UL zugelassene Netzkabel verwendet werden. Wenn dieses Produkt nach Kanada geliefert wird, muss das nachstehend für einen 100-120-Volt-Betrieb spezifizierte und von CSA zugelassene Netzkabel verwendet werden.

Steckerausführung	Parallele Steckzungen mit Erdungsstift (NEMA 5-15P-Konfiguration)
Kabel	Typ: SJT, drei 16 AWG (1,5 mm <sup>2</sup> )- oder 18 AWG (1,0 mm <sup>2</sup> )-Leiter
Länge	Max. 15 Fuß (4,5 m)
Nennleistung	Min. 10 A, 125 V

---

## Laser-Erklärung

**VORSICHT:** Wenn alle Abdeckungen und Gehäuseteile korrekt angebracht sind, handelt es um ein Produkt der Laserklasse 1. Der Strichcodescanner in diesem Produkt ist jedoch ein Laser Klasse II. Vermeiden Sie die Aussetzung an die von dem Strichcodescanner ausgehenden Strahlen. Blicken Sie nicht direkt in den Strahl.

**VORSICHT:** Die unsachgemäße Verwendung von Bedienelementen oder Einstellungen bzw. die Ausführung von Arbeitsschritten, die nicht in der mit dem Gerät gelieferten Dokumentation beschrieben sind, können dazu führen, dass gesundheitsschädigende Strahlungen freigesetzt werden.

---

## Hinweis zur Bibliotheksatterie

**VORSICHT:** Dieses Produkt enthält eine Lithium-Batterie. Das nichtflüchtige RAM, Dallas Semiconductor DS1743-100, enthält eine Lithium-Batterie. Lithium ist eventuell als gefährliches Material zu betrachten. Die Entsorgung dieser Batterie muss unter Einhaltung aller lokalen, regionalen und bundesweiten Gesetze und Vorschriften erfolgen.

---

## Hinweise zur MC300-Batterie

**VORSICHT:** Bei unsachgemäßem Austauschen der Batterie besteht Explosionsgefahr. Ersetzen Sie die Batterie nur mit dem gleichen oder einem gleichwertigen, vom Hersteller empfohlenen Typ. Bei der Entsorgung dieser Batterie müssen die Anweisungen des Herstellers beachtet werden.

---

## Español

---

### Declaración FCC

Este equipo ha sido sometido a prueba y ha demostrado cumplir con los límites de un dispositivo digital de Clase A, conforme a la Parte 15 de las Normas FCC. Estos límites están diseñados para proporcionar una protección razonable contra las interferencias perjudiciales cuando el equipo funciona en un entorno comercial. Este equipo genera, usa y puede emitir energía de radiofrecuencia y, si no se instala ni se usa de acuerdo con el manual de instrucciones, puede provocar interferencias perjudiciales para las comunicaciones de radio.

Cualesquiera cambios o modificaciones realizados a este equipo pueden anular la autoridad del usuario para utilizar este equipo.

El uso de este equipo en un área residencial puede provocar interferencias, en cuyo caso será el usuario quien tenga que correr con los gastos de las medidas que puedan ser necesarias para corregir las interferencias.

Este dispositivo cumple con la Parte 15 de las Normas FCC. El funcionamiento está sujeto a las siguientes condiciones:

- 1 Este dispositivo no debe causar interferencias perjudiciales, y
- 2 Este dispositivo debe aceptar cualquier interferencia que reciba, incluidas aquéllas que puedan provocar un funcionamiento no deseado.

---

## Declaración para Taiwán

警告使用者:

這是甲類的資訊產品，在居住的環境中使用時，可能會造成射頻干擾，在這種情況下，使用者會被要求採取某些適當的對策。

---

## Industria de Canadá (Aparato digital)

**Referencia:** *Interference-Causing Equipment Standard (Estándar para equipos que causan interferencia)*, ICES-003, Issue 2 (Tema 2)

Este aparato digital de Clase A cumple todos los requisitos de la normativa canadiense sobre equipos que causan interferencia.

---

### Advertencia CISPR-22

Éste es un producto de Clase A. En un entorno doméstico, este producto puede causar interferencias de radio, en cuyo caso puede ser necesario que el usuario tome medidas adecuadas.



---

## Aviso sólo para EE.UU. y CANADÁ

Si el producto se ha fabricado para EE.UU., utilice el cable de alimentación UL LISTED que se especifica más adelante para el funcionamiento a 100-120 V. Si el producto se ha fabricado para Canadá, utilice el cable de alimentación CSA CERTIFIED que se especifica más adelante para el funcionamiento a 100-120 V.

Enchufe	Cuchilla paralela con patilla de conexión a tierra (configuración NEMA 5-15P)
Cable Tipo	SJT, tres cables 16 AWG (1,5 mm <sup>2</sup> ) ó 18 AWG (1,0 mm <sup>2</sup> )
Longitud	Máxima de 15 pies (4,5m)
Clasificación	Máximo 10 A, 125 V

---

## Declaración sobre láser

**PRECAUCIÓN:** Con todos los paneles y cubiertas en su sitio, este producto se clasifica como un producto láser de Clase I. Sin embargo, el lector de código de barras que hay en el interior de este producto es un láser de Clase II. Evite la exposición a la luz del láser que emite el lector de código de barras. No mire fijamente el rayo.

**PRECAUCIÓN:** El uso de controles o ajustes o la realización de procedimientos distintos de los que se especifican en este manual pueden provocar una exposición peligrosa.

---

## Declaración sobre la batería de la biblioteca

**PRECAUCIÓN:** Este producto contiene una batería de litio. La memoria RAM no volátil, Dallas Semiconductor DS1743-100, contiene una batería de litio. El litio puede ser considerado un material peligroso. Deseche la batería conforme a la norma vigente de aplicación local, del estado y federal.

---

## Declaración sobre la batería MC300

**PRECAUCIÓN:** Peligro de explosión si la batería se cambia de forma incorrecta. Reemplace la batería únicamente por el mismo tipo o un tipo equivalente recomendado por el fabricante. Deseche las baterías usadas de acuerdo con las instrucciones del fabricante.

---

## Français

---

### Déclaration de la FCC

Cet équipement a été testé et s'est révélé conforme aux limites d'un appareil numérique de Classe A, conformément à l'alinéa 15 de la réglementation de la FCC. Ces limites sont conçues pour fournir une protection adéquate contre les perturbations nuisibles lorsque l'équipement fonctionne dans un environnement commercial. Cet équipement génère, utilise et peut émettre une énergie à fréquence radio et risque, s'il n'est pas installé et utilisé conformément au manuel d'instruction, de créer des perturbations nuisibles aux services de radiocommunication.

Tout changement ou modification apporté à cet équipement risque d'annuler le droit d'utiliser l'équipement.

L'utilisation de cet équipement dans une zone résidentielle risque de créer des perturbations auxquelles l'utilisateur devra remédier à ses propres frais.

Cet appareil est conforme à l'alinéa 15 de la réglementation de la FCC. Le fonctionnement de cet équipement est soumis aux conditions suivantes :

- 1 Cet appareil ne peut générer de perturbations nuisibles et
- 2 Cet appareil doit accepter les perturbations reçues, notamment les perturbations qui risquent de générer un fonctionnement non souhaité.

---

## Réglementation de Taïwan

**警告使用者:**

這是甲類的資訊產品，在居住的環境中使用時，可能會造成射頻干擾，在這種情況下，使用者會被要求採取某些適當的對策。

---

## Industrie Canada (Appareil numérique)

**Référence** : Norme sur le matériel brouilleur, NMB-003, numéro 2

Cet appareil numérique de Classe A satisfait à toutes les exigences des réglementations canadiennes sur le matériel brouilleur.

---

### **Avertissement CISPR-22 !**

Ceci est un produit de Classe A. Dans un environnement résidentiel, ce produit risque de générer des perturbations radio auxquelles l'utilisateur doit peut-être remédier.

---

## Avis pour les États-Unis et le Canada uniquement

En cas d'envoi aux États-Unis, utilisez le câble d'alimentation CLASSÉ UL spécifié ci-dessous pour un fonctionnement à 100-120 V. En cas d'envoi au Canada, utilisez le câble d'alimentation CERTIFIÉ CSA spécifié ci-dessous pour un fonctionnement à 100-120 V.

Fiche	Broche parallèle avec broche de mise à la terre (configuration NEMA 5-15P)
Cordon	Type : SJT, trois fils 16 AWG (1,5 mm <sup>2</sup> ) ou 18 AWG (1,0 mm <sup>2</sup> )
Longueur	15 pieds (4,5 m) au maximum
Courant nominal	10 A au minimum, 125 V

---

## Réglementation relative au laser

**ATTENTION** : Avec tous les panneaux et enceintes en place, ce produit est classé comme un produit laser de Classe I. Le lecteur de codes-barres à l'intérieur de ce produit est, cependant, un laser de Classe II. Évitez toute exposition à la lumière laser émise par le lecteur de codes-barres. Ne fixez pas le faisceau des yeux.

**ATTENTION** : L'utilisation de commandes ou de réglages ou l'exécution de procédures autres que celles spécifiées ici peuvent entraîner une exposition dangereuse.

---

## Réglementation relative à la pile de la bibliothèque

**ATTENTION** : Ce produit comporte une batterie au lithium. La mémoire RAM non-volatile, Dallas Semiconductor DS1743-100, comporte une pile au lithium. Le lithium peut être considéré comme un matériau dangereux. Mettez cette batterie au rebut conformément aux lois locales, nationales et fédérales.

---

## Conformité de la pile MC300

**ATTENTION** : Il existe un risque d'explosion si la pile n'est pas correctement remplacée. Remplacez la batterie par une batterie du même modèle ou d'un modèle équivalent, selon les recommandation du fabricant. Pour vous débarrasser de la pile usagée, suivez les consignes du fabricant.

---

## Italiano

---

### Dichiarazione FCC

Questa apparecchiatura è stata provata e trovata conforme ai limiti per i dispositivi digitali di Classe A, relativi alla Parte 15 delle norme FCC. Questi limiti sono concepiti per garantire un livello ragionevole di protezione da interferenze dannose quando l'apparecchiatura viene azionata in un ambiente commerciale. Questa apparecchiatura genera, utilizza e può irradiare energia a radiofrequenza e, se non installata e utilizzata secondo il manuale di istruzioni, potrebbe causare interferenze dannose alle comunicazioni radio.

Eventuali cambiamenti o modifiche apportati a questa apparecchiatura potrebbero invalidare il diritto dell'utente ad utilizzare questa apparecchiatura.

Il funzionamento dell'apparecchiatura in una zona residenziale potrebbe causare interferenze, nel qual caso l'utente dovrà a proprie spese prendere i dovuti provvedimenti per eliminare le interferenze.

Questo dispositivo è conforme alla Parte 15 delle norme FCC. Il funzionamento è soggetto alle seguenti condizioni:

- 1 Questo dispositivo non può causare interferenze dannose e
- 2 Questo dispositivo deve accettare eventuali interferenze ricevute, incluse le interferenze causate da funzionamento indesiderato.

---

### Dichiarazione per Taiwan

**警告使用者:**

這是甲類的資訊產品，在居住的環境中使用時，可能會造成射頻干擾，在這種情況下，使用者會被要求採取某些適當的對策。

---

## Industry Canada (apparati digitali)

**Riferimento:** *Interference-Causing Equipment Standard, ICES-003, 2.* edizione

Questo dispositivo digitale di Classe A è conforme a tutti i requisiti dei regolamenti canadesi per apparecchiature che causano interferenze.

---

### **Avvertenza CISPR-22!**

Questo è un prodotto di Classe A. In un ambiente domestico questo prodotto potrebbe causare interferenze radio; in tal caso l'utente dovrà adottare tutti i dovuti provvedimenti.

---

## Avviso esclusivamente per Stati Uniti e Canada

Se il prodotto viene spedito negli Stati Uniti, utilizzare il cavo di alimentazione elencato UL, specificato di seguito per il funzionamento a 100-120 V. Se il prodotto viene spedito in Canada, utilizzare il cavo di alimentazione certificato CSA, specificato di seguito per il funzionamento a 100-120 V.

Cappuccio della spina	Lama parallela con perno di terra (configurazione NEMA 5-15P)
Cavo:	Tipo: SJT, tre fili da 16 AWG (1,5 mm <sup>2</sup> ) o 18 AWG (1,0 mm <sup>2</sup> )
Lunghezza	Massima di 15 piedi (4,5 m)
Portata	Minima di 10 A, 125 V

---

## Dichiarazione sui dispositivi laser

**ATTENZIONE:** Con tutti i pannelli e le custodie in posizione, questo prodotto è classificato come prodotto laser di Classe I. Lo scanner per codici a barre all'interno del prodotto è invece un dispositivo laser di Classe II. Evitare l'esposizione ai raggi laser emessi dallo scanner per codici a barre. Non guardare fisso nel fascio di luce.

**ATTENZIONE:** L'utilizzo di comandi, regolazioni o procedure diversi da quelli specificati in questa sede potrebbe causare livelli di esposizione pericolosi.

---

## Dichiarazione sulla batteria della libreria

**ATTENZIONE:** Questo prodotto contiene una batteria al litio. La RAM non volatile, di tipo Dallas Semiconductor DS1743-100, contiene una batteria al litio. Il litio potrebbe essere considerato un materiale pericoloso. Smaltire la batteria secondo quanto previsto dalle leggi locali, regionali e nazionali.

---

## Dichiarazione sulla batteria MC300

**ATTENZIONE:** Qualora la batteria venga sostituita in modo non corretto, esiste il pericolo di esplosione. Sostituire solo con lo stesso tipo di batteria o con un tipo equivalente consigliato dal produttore. Smaltire le batterie utilizzate secondo le istruzioni del produttore.

---

## Svenska

---

### FCC-meddelande

Utrustningen har testats och befunnits uppfylla gränserna för en klass A digital enhet i enlighet med del 15 i FCC-reglerna. Gränserna är utformade att tillhandahålla rimligt skydd mot störningar när utrustningen används i en kommersiell miljö. Utrustningen alstrar, använder och kan utstråla radiofrekvent energi och kan, om den ej installeras och används i enlighet med instruktionshandboken, orsaka störningar i radiokommunikation.

Eventuella ändringar eller modifikationer av utrustningen kan ogiltigförklara användarens rätt att använda utrustningen.

Användning av utrustningen i bostadsområden kan orsaka störningar och i sådana fall måste användaren bekosta de åtgärder som krävs för att åtgärda störningarna.

Enheten uppfyller del 15 i FCC-reglerna. Användningen underkastas följande villkor:

- 1 Enheten får inte orsaka störningar och
- 2 enheten måste tåla mottagna störningar, inklusive störningar som kan orsaka oönskad funktion.

---

## Meddelande för Taiwan

警告使用者:

這是甲類的資訊產品，在居住的環境中使用時，可能會造成射頻干擾，在這種情況下，使用者會被要求採取某些適當的對策。

---

## Kanada (digital utrustning)

**Hänvisning:** *Standard för störningsalstrande utrustning, ICES-003, utgåva 2*

Denna klass A för digital utrustning uppfyller alla krav i de kanadensiska föreskrifterna för störningsalstrande utrustning.

---

### CISPR-22Varning!

Detta är en klass A produkt. I en hemmiljö kan denna produkt orsaka radiostörningar, i vilket fall det kan krävas att användaren vidtar lämpliga åtgärder.

---

## Meddelande för USA och KANADA enbart

Om utrustningen levereras i USA, använd den UL-listade nätsladden som specificeras nedan för användning med 100-120 V. Om utrustningen



levereras i Kanada, använd den CSA-certifierade nätsladden som specificeras nedan för användning med 100-120 V.

Kontaktkåpa	Parallellt blad med jordstift (NEMA 5-15P-konfiguration)
Sladd	Typ: SJT, tre 1,5 mm <sup>2</sup> (16 AWG) eller 1,0 mm <sup>2</sup> (18 AWG) ledare
Längd	Maximalt 15 fot (4,5 m)
Märkvärde	Minimalt 10 A, 125 V

---

## Lasermeddelande

**FÖRSIKTIGHET:** Med alla paneler och luckor på plats klassificeras denna produkt som en laserprodukt klass 1. Streckkodsläsaren inuti produkten är klassificerad som en laserprodukt klass II. Undvik kontakt med streckkodsläsarens laserstråle. Titta inte in i strålen.

**FÖRSIKTIGHET:** Användning av kontroller, justeringar eller utförande av rutiner andra än de som anges i detta dokument kan leda till farlig exponering för strålning.

---

## Meddelande om biblioteks batteri

**FÖRSIKTIGHET:** Produkten innehåller ett litiumbatteri. Det icke-flyktiga RAM-minnet, Dallas halvledare DS1743-100, innehåller ett litiumbatteri. Litium anses som riskavfall. Kasta batteriet i enlighet med lokala och nationella lagar.

---

## Meddelande om MC300-batteri

**FÖRSIKTIGHET:** Det finns risk för explosion om batteriet inte byts på rätt sätt. Byt enbart till samma eller likvärdig batterityp som rekommenderas av tillverkaren. Kasta förbrukade batterier i enlighet med tillverkarens anvisningar.

---

## 简体中文 Simplified Chinese

---

### FCC 声明

此设备已经过测试，符合 FCC 规则第 15 部分中对 A 级数字设备的限制。这些限制旨在对该设备用于商业环境时产生的有害干扰提供合理保护。此设备产生、使用射频能量，并可能辐射该能量，如果未根据安装手册安装和使用，还可能会对无线电通信造成有害干扰。

对此设备进行任何更改或修改都可能导致用户无权操作此设备。

在住宅区操作此设备时可能会造成干扰，在此情况下，用户需自行采取必要措施来纠正干扰。

此设备符合 FCC 规则第 15 部分的规定。操作时需符合以下条件：

- 1 此设备不会造成有害干扰，并且
- 2 此设备必须接受收到的任何干扰，包括可能导致非要求操作的干扰。

---

### 台湾声明

**警告使用者:**

這是甲類的資訊產品，在居住的環境中使用時，可能會造成射頻干擾，在這種情況下，使用者會被要求採取某些適當的對策。

---

### 加拿大工业部（数字设备）

**参考：**设备引起干扰标准，ICES-003 第 2 版

此 A 级数字设备符合《加拿大引起干扰设备规则》的所有要求。

**CISPR-22 警告!**

此为 A 级产品。在住宅环境中使用此产品时，可能会造成无线电干扰，在此情况下，用户需采取适当的措施。

**仅限于美国和加拿大的声明**

如果设备运往美国，请使用下面为 100-120 V 操作环境指定的 UL LISTED D 电源线。如果设备运往加拿大，<sup>map</sup>请使用下面为 100-120 V 操作环境指定的 CSA CERTIFIED 电源线。

插头	带接地脚的平行叶片（NEMA 5-15P 配置）
电源线	类型：SJT、三根 16 AWG（1.5 平方毫米 <sup>2</sup> ）或 18 AWG（1.0 平方毫米 <sup>2</sup> ）导线
长度	最长 4.5 米（15 英尺）
额定值	最小 10 A、125 V

**激光声明****1 级激光产品**

**注意：**所有面板和机壳均存在的情况下，此产品被列入 I 级激光产品。但是，此产品内的条形码扫描器是 II 级激光产品。请避免遭受条形码扫描器发出的激光辐射。请勿直视激光光束。

**注意：**使用本文档中未指定的控制、调整或执行过程可能会导致危险。

**库存机电池声明****注意**

此产品包含锂电池。非易失性 RAM 采用 Dallas 半导体 DS1743-100，其中包含锂电池。锂被视为危险材料。处理此电池时应遵照当地、州和联邦的法律。

---

## MC300 電池聲明

---

### 注意

如果未正确更換電池，則存在爆炸危險。

只能使用相同類型或製造商建議的同等類型的電池進行更換。請按照製造商提供的說明處理廢舊電池。

---

## 繁體中文 Traditional Chinese

---

### FCC 聲明

此裝置經測試，符合 FCC 規則第 15 部份中對 A 級數位裝置的限制。這些限制旨在提供合理保護，防止該裝置工作於商業環境時產生有害干擾。此裝置產生、使用射頻能量，並可能輻射射頻能量，如果未根據說明手冊安裝和使用，可能會對無線電通訊造成有害干擾。

對此裝置進行任何變更或修改都可能導致使用者操作此裝置授權無效。

在住宅區操作此裝置時可能會造成干擾，在此情況下，使用者需自行採取必要措施來糾正干擾。

此裝置符合 FCC 規則第 15 部份的規定。操作時需符合以下條件：

- 1 此裝置不會造成有害干擾，並且
- 2 此裝置必須接受收到的任何干擾，包括可能導致意外操作的干擾。

---

## 臺灣聲明

### 警告使用者:

這是甲類的資訊產品，在居住的環境中使用時，可能會造成射頻干擾，在這種情況下，使用者會被要求採取某些適當的對策。

---

## 加拿大工業部（數位裝置）

**參考：**引起干擾的裝置標準，ICES-003 第 2 次發行

此 A 級數位裝置符合《加拿大引起干擾裝置之規則》的所有要求。

---

### **CISPR-22 警告！**

此為 A 級產品。在住宅環境中使用此產品時，可能會造成無線電干擾，在此情況下，使用者可能需採取適當的措施。

---

## 僅限於美國和加拿大的聲明

如果裝置運往美國，請使用下面指定的針對 100-120 V 操作環境的 UL LISTED 電源線。如果裝置運往加拿大，請使用下面指定的針對 100-120 V 操作環境的 CSA CERTIFIED 電源線。

插頭	帶接地針腳的平行葉片（NEMA 5-15P 設定）
電源線	類型：SJT、三根 16 AWG（1.5 平方公釐）或 18 AWG（1.0 平方公釐）導線
長度	最長 4.5 公尺
額定值	最小 10 A、125 V

---

## 鐳射聲明

---

### 1 級鐳射產品

**注意：**所有面板和機殼均安全到位的情況下，此產品被列入 I 級鐳射產品。但是，此產品內的條碼掃描器是 II 級鐳射產品。請避免遭受條碼掃描器發出的鐳射光照射。請勿直視鐳射光束。

**注意：**使用本手冊中未指定的控制、調整或執行過程可能會導致危險。

---

## 媒體櫃電池聲明

---

### 注意

此產品包含鋰電池。非易失性 RAM 採用 Dallas 半導體 DS1743-100，其中包含鋰電池。鋰被視為危險材料。處理此電池時應遵照當地、州和聯邦的法律。

---

## MC300 電池聲明

---

### 注意

如果未正確更換電池，則存在爆炸危險。

只能使用相同類型或製造商建議的同等類型的電池進行更換。請按照製造商提供的說明處理廢舊電池。

---

## 日本語 Japanese

---

### FCC に関する記述

この装置はテスト済みであり、FCC ルール Part 15 に規定された仕様のクラス A デジタル装置の制限に適合していることが確認済みです。これらの制限は、商業環境で装置を使用したときに、干渉を防止する適切な保護を規定しています。この装置は、無線周波エネルギーを生成、使用、または放射する可能性があり、この装置のマニュアルに記載された指示に従って設置および使用しなかった場合、ラジオ/テレビの受信障害が起こることがあります。

この装置を変更または改造すると、この装置を操作するユーザー権が無効になることがあります。

住宅地でこの装置を使用すると、干渉を引き起こす可能性があります。その場合には、ユーザー側の負担で干渉防止措置を講じる必要があります。

この装置は FCC ルール Part 15 に準拠しています。動作は次の条件に従っていなければなりません。

- 1 当該装置によって、有害な干渉が発生することはない。
- 2 当該装置は、予想外の動作を引き起こす可能性のある干渉も含め、すべての干渉を受け入れなければならない。

---

### 台湾

**警告使用者:**

這是甲類的資訊產品，在居住的環境中使用時，可能會造成射頻干擾，在這種情況下，使用者會被要求採取某些適當的對策。

---

## Industry Canada (デジタル機器)

参照： *Interference-Causing Equipment Standard*、ICES-003、Issue 2

このクラス A デジタル機器は *Canadian Interference-Causing Equipment Regulations* で定められている条件を満たします。

---

### **CISPR-22 警告**

これはクラス A 製品です。国内で使用する場合、電波障害を引き起こす恐れがあります。適切な処置を行ってください。



## アメリカ合衆国とカナダの通知

アメリカ合衆国に出荷した場合、100～120 V 以下での操作用に指定された UI 一覧の電源コードを使用してください。カナダに出荷した場合、100～120 V 以下での操作用に指定された CSA 認定の電源コードを使用してください。

プラグキャップ	アースピン付き (NEMA 5-15P)
コードの	種類 : SJT、16 AWG (1.5 mm <sup>2</sup> ) × 3 または 18 AWG (1.0 mm <sup>2</sup> ) ワイヤ
長さ	最大 15 フィート (4.5m)
定格最低	10 A、125 V

## レーザー製品に関する記述

### クラス 1 レーザー製品

**注意：**すべてのパネルとエンクロージャが定位置にある状態で、この製品はクラス 1 レーザー製品に指定されています。当製品内部のバーコードはクラス II レーザーです。バーコードスキャナのレーザー光線との接触を避けてください。光線を見つめないでください。

**注意：**ここに指定された以外の方法で制御、調整、パフォーマンスを行った場合、危険な照射が起こることがあります。

## ライブラリバッテリーに関する記述

### 注意

この製品にはリチウムバッテリーが入っています。不揮発性 RAM である Dallas Semiconductor DS1743-100 にはリチウムバッテリーが含まれています。リチウムは危険性物質と見なされることがあります。このバッテリーを破棄するときは、地方、州、および連邦法に従ってください。

---

## MC300 배터리に関する記述

---

### 注意

배터리が正しく交換されないと、爆発する危険があります。

メーカー推奨と同じか同等の種類 배터리とのみ交換してください。  
 使用済みの 배터리는メーカーの指示に従って破棄してください。

---

## 한국어 Korean

---

### FCC 표시

이 장비는 FCC Rules 의 Part 15 에 의하여 테스트되고 Class A 디지털 장치에 대한 제한사항을 준수하는 것으로 검증되었습니다. 이 제한사항은 장비가 상업적 환경에서 작동할 때 해로운 간섭에 대해 적절히 보호되도록 고안되었습니다. 이 장비는 라디오 주파수 에너지를 생성, 사용 및 방출할 수 있고 지시사항에 따라 설치 및 사용되지 않는 경우 무선 통신에 해로운 간섭을 유발할 수 있습니다.

이 장비를 변경 또는 수정하는 경우 장비를 작동하는 사용자의 권한은 무효가 됩니다.

거주 지역에서의 장비를 작동하는 경우 간섭을 유발할 수 있으며, 이 경우 사용자는 자신의 부담으로 간섭을 정정하기 위해 필요한 모든 조치를 취해야 합니다.

이 장치는 FCC Rules 의 Part 15 를 준수합니다. 작동에는 다음 조건이 필요합니다.

- 1 이 장치는 해로운 간섭을 유발할 수 없으며, 또한
- 2 원하지 않는 작동을 유발할 수 있는 간섭을 포함하여 수신되는 모든 간섭을 수용해야 합니다.

---

## 대만 정책

警告使用者:

這是甲類的資訊產品，在居住的環境中使用時，可能會造成射頻干擾，在這種情況下，使用者會被要求採取某些適當的對策。

---

## 캐나다 산업 ( 디지털 장치 )

참조 : 간섭 유발 장비 표준, ICES-003, Issue 2

이 Class A 디지털 장치는 캐나다 간섭 유발 장비 규정의 모든 요구사항을 충족합니다.

---

### **CISPR-22 경고 !**

이것은 Class A 제품입니다. 국내 환경에서 이 제품은 사용자가 충분한 조치를 취해야 하는 무선 간섭을 유발할 수 있습니다.

## 유의사항 ( 미국 및 캐나다에만 해당 )

미국으로 출시되는 경우 100-120 V 작동을 위해 아래에 지정된 UL LISTED 전원 코드를 사용하십시오. 캐나다로 출시되는 경우 100-120 V 작동을 위해 아래에 지정된 CSA CERTIFIED 전원 코드를 사용하십시오.

플러그 캡	접지 핀이 부착된 병렬 전극 (NEMA 5-15P 구성)
코드	유형: SJT, 3 선 16 AWG (1.5mm <sup>2</sup> ) 또는 18 AWG (1.0mm <sup>2</sup> ) 전선
길이	최대 4.5m (15 피트)
정격	최소 10A, 125V

## 레이저 표시

### Class 1 레이저 제품

**주의 :** 모든 패널과 인클로우저가 제 위치에 있을 때 이 제품은 Class I 레이저 제품으로 평가됩니다. 그러나 이 제품 안에 있는 바코드 스캐너는 Class II 레이저입니다. 바코드 스캐너에서 방출되는 레이저 빛에 노출되지 마십시오. 빔을 바라보지 마십시오.

**주의 :** 여기에서 지정된 것을 제외한 절차를 제어, 조정 및 수행하는 경우 위험한 결과를 초래할 수 있습니다.

## 라이브러리 배터리 표시

### 주의

이 제품에는 리튬 배터리가 들어 있습니다. 비휘발성 RAM, Dallas Semiconductor DS1743-100 은 리튬 배터리를 포함하고 있습니다. 리튬은 유해 물질로 간주됩니다. 지방, 주 및 연방법에 따라 이 배터리를 폐기하십시오.

---

## MC300 배터리 표시

---

### 주의

배터리를 잘못 교체하면 폭발 위험성이 있습니다.

동일 제품이나 제조업체가 권장하는 제품으로만 교체하십시오.  
사용한 배터리는 제조업체의 지시에 따라 폐기하십시오.

# Declaration of Conformity

Figure 64 Declaration of Conformity, ATL M1500





<b>Quantum</b>	<b>DECLARATION OF CONFORMITY</b> According to EN45014
<b>Manufacturer's Name:</b>	Quantum Corporation
<b>Manufacturer's Address:</b>	141 Innovation Drive Irvine, CA 92612-3040 USA
<b>Declares that the Product(s):</b>	
Product Description	Automated Tape Library System
Product Name:	ATL M Series
Model Number(s):	M1500, L25
Product Options:	All
<b>Conforms to the following EC Directives and EC Standards:</b>	
<b>Low Voltage Directive 73/23/EEC</b>	
Product Safety:	EN60950:1992, + A1, A2, A3, A4, A11 EN60825-1:1994, + A11
<b>EMC Directive 89/336/EEC</b>	
EMC:	EN55022:1997, Class A EN61000-3-2:1995, Class A EN61000-3-3:1994 EN55024:1998 EN61000-4-2:1995 EN61000-4-3:1995 EN61000-4-4:1994 EN61000-4-5:1994 EN61000-4-6:1996 EN61000-4-8:1993 EN61000-4-11:1994
<b>Authorizing Signature:</b>	
 Mitchell Gilbert Manager, Regulatory	<b>Date Issued: 06/05/2003</b>
<b>European Headquarters:</b> 7 Lindenwood, Chincham Business Park Basingstoke, Hampshire RG24 8WD, United Kingdom Telephone: +44 (1) 256 848 713 Fax: +44 (1) 256 848 700	
	

Figure 65 Declaration of Conformity, ATL M2500

<b>Quantum</b>	<b>DECLARATION OF CONFORMITY</b> According to EN45014
<b>Manufacturer's Name:</b>	Quantum Corporation
<b>Manufacturer's Address:</b>	141 Innovation Drive Irvine, CA 92612-3040 USA
<b>Declares that the Product(s):</b>	
Product Description:	Automated Tape Library System
Product Name:	ATL M Series
Model Number(s):	M2500, L100
Product Options:	All
<b>Conforms to the following EC Directives and EC Standards:</b>	
<b>Low Voltage Directive 73/23/EEC</b>	
Product Safety:	EN60950:1992, + A1, A2, A3, A4, A11 EN60825-1:1994, + A11
<b>EMC Directive 89/336/EEC</b>	
EMC:	EN55022:1997, Class A EN61000-3-2:1995, Class A EN61000-3-3:1994 EN55024:1998 EN61000-4-2:1995 EN61000-4-3:1995 EN61000-4-4:1994 EN61000-4-5:1994 EN61000-4-6:1996 EN61000-4-8:1993 EN61000-4-11:1994
<b>Authorizing Signature:</b>	
 Mitchell Gilbert Manager, Regulatory	<b>Date Issued: 06/05/2003</b>
<b>European Headquarters:</b> 7 Lindenwood, Chincham Business Park Basingstoke, Hampshire RG24 8WD, United Kingdom Telephone: +44 (1) 256 848 713 Fax: +44 (1) 256 848 700	
	



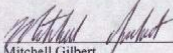

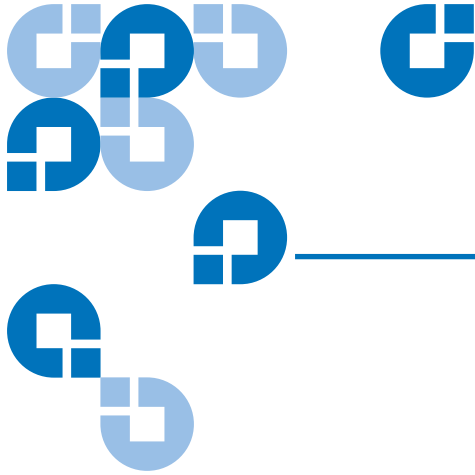

# Glossary

---

## B

**back panel** The panel at the back of the library that contains the power switch and connectors for attaching external cabling to the library.

**bar code label** The identification label on cartridges.

**bar code scanner** A laser device that is mounted on the robotic hand and reads the cartridge bar code labels.

---

## C

**calibration** The software measurements and configuration required for successful operation of the library.

---

## F

**FCC Class A** Standard established by the U.S. Federal Communications Commission governing electromagnetic emissions.

**FSE** Field service engineer

---

## G

**GUI** Graphical user interface. The panel on the front of the ATL M-Series libraries that provides the user interface.

---

## H

**host computer** The computer that issues SCSI commands to control the library robotics.

<hr/> <b>M</b>	<b>MTBF</b> Mean Time Between Failures <b>MTTR</b> Mean Time To Repair
<hr/> <b>N</b>	<b>NVRAM</b> Nonvolatile random access memory
<hr/> <b>O</b>	<b>on-line</b> Ready for communications with a host
<hr/> <b>P</b>	<b>pick</b> The act of removing a cartridge from one location in preparation for placing it in another location. <b>place</b> The act of placing a cartridge in a location after it has been picked from another location. <b>PROM</b> Programmable read-only memory
<hr/> <b>R</b>	<b>RAM</b> Random access memory
<hr/> <b>S</b>	<b>SCSI</b> Small Computer System Interface. A communications standard for attaching peripheral equipment to small computers.
<hr/> <b>T</b>	<b>tape drive</b> The mechanism that reads data from, and writes data to, a tape.
<hr/> <b>U</b>	<b>UL</b> Underwriters Laboratories

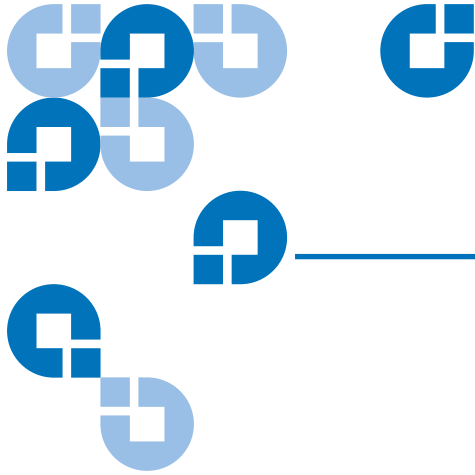

# Index

---

---

## A

- Auto-Clean option, turning on or off 66–67
- Auto-Import option, turning on or off 68

---

## B

- Back panel 10
- Bar code scanner, enabling or disabling 61
- Barcode Scanner test, running 79–80
- Baud rate, setting 62

---

## C

- cable, SCSI, length 108
- Cartridge magazines, removing 35–42
- Cartridges
  - handling 161–162
  - importing and exporting 29–35
  - inspecting for damage 162–164
  - moving 25–28
- Cleaning a tape drive 71–72
- Confidence test 94–95
- Configuration screen, accessing 49
- Configuration, library, changing 49–68
- Contrast, GUI, adjusting 75

---

## D

- Date, setting 63
- Demonstration programs, running 93–100
- Diagnostic tests, running 77–87
  - Barcode Scanner test 79–80
  - Display test 87
  - Move Location test 84–87
  - Move Medium test 81–84
- Diagnostics Menu screen, accessing 77
- Display test 87
- Drive
  - cleaning 71–72
  - firmware, updating 89–92
  - information, viewing 21
  - power, turning on or off
    - using Quick View Menu screen 23–25
    - using the Maintenance screen 73–74
  - serialization, turning on or off 58
  - statistics, viewing 45

---

## E

- Emulation, setting 54
- Exporting tape cartridges 29–35

---

## F

- Fault symptom codes
  - see FSCs
- Firmware, drive, updating 89–92
- Front panel 5
- FSCs 109–160

---

## G

- GUI
  - contrast, adjusting 75
  - overview 14–18

---

## I

- Ignore Host Lock option, turning on or off 67
- Illumination, turning on or off 59
- Import/Export option, setting 64–66
- Importing tape cartridges 29–35
- Information, viewing
  - drive 21
  - inventory 22
  - library 20
- Inventory information, viewing 22

---

## L

- Library
  - configuration, changing 49–68
  - features 5–11
    - back panel 10
    - front panel 5
  - information, viewing 20
  - statistics, viewing 44

---

## M

- Magazines, removing 35–42
- Maintenance screen, accessing 69
- Manual access port (MAP) 64

Move Location test, running 84–87

Move Medium test, running 81–84

---

## O

Off-line time, setting 60

---

## Q

Quick View Menu screen 19–25

---

## S

SCSI

- cable length 108

- history, viewing 46

- IDs, setting

  - library 51

  - tape drive 51–53

SCSI II specification xvi

Serialization, turning on or off 58

Short Labels option, turning on or off 58

Statistics, library, viewing 42–46

Storage Slot Count setting, changing 55

Sync negotiation, turning on or off 56

---

## T

Tape cartridges

- handling 161–162

- importing and exporting 29–35

- inspecting for damage 162–164

- moving 25–28

Tape drive

- cleaning 71–72

- firmware, updating 89–92

Terminator power

- turning on or off 53

Time, setting 62–63

---

## U

Updating drive firmware 89–92

---

## W

Wide negotiation, turning on or off 57

