

# LTO-6 Tape Drive Quick Start Guide

---

LTO Ultrium tape drives leverage LTO technology and exclusive features to provide the most reliable and affordable tape data protection to medium and large businesses.

The LTO-6 tape drive is available in the following models:

- LTO-6 Half-Height Internal tape drive
- LTO-6 Half-Height external tape drive

These drives are the most reliable Ultrium drives on the market, delivering reliability features to extend media life and Variable-speed Transfer to automatically match the host's data transfer rate. Combined with SmartVerify to concurrently verify all data written to the tape, these features make LTO drives a sound investment and a complete data protection solution.

## Contents

Before Installing the LTO-6 Tape Drive..	2
Handling Precautions and Installation Guidelines.....	2
Preinstallation Requirements .....	3
Unpacking and Inspecting the Drive .	4
Installing the Internal LTO-6 Tape Drive	4
Mounting the Internal Half-Height Tape Drive .....	5
Connecting the Internal Half-Height Drive Interfaces .....	7
Restarting the Internal Half-Height Tape Drive System .....	7
Installing the Tabletop LTO-6 Tape Drive	8
Connecting the Tabletop Drive Interface and AC Power Cables .....	8
Restarting the Tabletop Half-Height Tape Drive System .....	9
Installing the LTO Driver Software .....	9
Safety Compliances .....	10
Electromagnetic Compatibility (EMC) Compliances .....	11

Figure 1 Internal Drive (Half Height)



## Before Installing the LTO-6 Tape Drive

### Handling Precautions and Installation Guidelines

Always observe the following precautions and guidelines when handling and installing LTO-6 Tape Drives:

- Internal, at all times
- Tabletop, when removed from its free-standing enclosure

<b>Handling Precautions</b>	<ul style="list-style-type: none"> <li>• Internal drives have exposed components that are sensitive to static electricity. To reduce the possibility of damage from static discharge, the drives are packaged in a protective antistatic bag. Do not remove the drive from the antistatic bag until you are ready to install it.</li> <li>• Wear an ESD-preventive grounding wrist strap or observe similar ESD precautions when working with the drive. Be sure the wrist strap makes good skin contact. Do not remove the wrist strap until you finish working with the drive. Also, avoid contact between the drive, other equipment, and clothing. The wrist strap only protects the equipment from ESD voltages on the body; ESD voltages on clothing can still cause damage.</li> <li>• Before removing the drive from the antistatic bag, touch a grounded metal surface to discharge any static electricity buildup from your body.</li> <li>• Handle the drive by its sides rather than by the top cover to reduce the risk of dropping the drive or damaging it during installation.</li> <li>• Either lay the drive on a nonconductive surface or put it back inside the protective antistatic bag to reduce the chance of damage from static discharge</li> </ul>
<b>Installation Guidelines</b>	<ul style="list-style-type: none"> <li>• For optimum performance, do not connect more than two LTO-6 drives to the same host bus adapter (HBA).</li> </ul>

## Preinstallation Requirements

Before installing the LTO-6 Tape Drive, make sure you have:

- A serial SCSI host bus adapter (HBA) installed and properly configured in the host computer
- Interface components, either:
  - 29-pin SFF-8482 SAS cable
  - 26-pin SFF-8088 mini-SAS style interface cable for a tabletop drive
- Backup application software that supports the tape drive.

---

## Unpacking and Inspecting the Drive

---

Although each LTO-6 Tape Drive is inspected and carefully packaged at the factory, damage can occur in shipment or when the drive is being unpacked.

Observe the handling precautions in [Handling Precautions and Installation Guidelines](#), and carefully unpack and inspect the LTO-6 Tape Drive as follows:

- 1 Visually inspect the shipping container and notify your carrier immediately of any damage.
- 2 Place the shipping container on a flat, clean, stable surface and carefully remove the contents.
- 3 Visually inspect the LTO-6 Tape Drive and notify your sales representative immediately of any damage.
- 4 Always save the shipping container and packing materials for any future reshipment.

---

## ESD Precautions

---

Your internal tape drive has very sensitive components that are prone to damage from electrostatic discharge (ESD). Use extreme care when handling the drive, as it can be damaged by ESD. Before handling the drive, read the following instructions.

- Wear an ESD-preventive grounding wrist strap or observe similar ESD precautions when working with the drive. Be sure the wrist strap makes good skin contact. Do not remove the wrist strap until you finish working with the drive.
- Avoid contact between the drive, other equipment, and clothing. The wrist strap only protects the equipment from ESD voltages on the body; ESD voltages on clothing can still cause damage.
- When the drive is not being used, keep it in its antistatic bag.
- Before you remove the drive from the antistatic bag, touch a metal or grounded surface to discharge any static electricity buildup from your body.
- Hold the drive by its edges only. Avoid touching any exposed parts on the printed circuit board.
- Always place the drive on top of or inside the antistatic bag to reduce the chance of ESD damage.

---

# Installing the Internal LTO-6 Tape Drive

---

## Installing the Internal LTO-6 Half-Height Tape Drive

---

To install the internal LTO-6 Half-Height Tape Drive, complete the following procedures in the order presented:

- 1 [Mounting the Internal Half-Height Tape Drive](#) on page 5
- 2 [Connecting the Internal Half-Height Drive Interfaces](#) on page 7
- 3 [Restarting the Internal Half-Height Tape Drive System](#) on page 7

4 [Installing the LTO Driver Software](#) on page 9, if required

### Mounting the Internal Half-Height Tape Drive

You can mount the internal LTO-6 Half-Height Tape Drive either horizontally or vertically, but not upside down (see [figure 2](#)).

IF you mount the drive . . .	THEN the . . .
horizontally,	base of the drive must be within 15 degrees of horizontal.
vertically,	side of the drive must be within 5 degrees of horizontal.

Figure 2 Acceptable Mounting Orientations

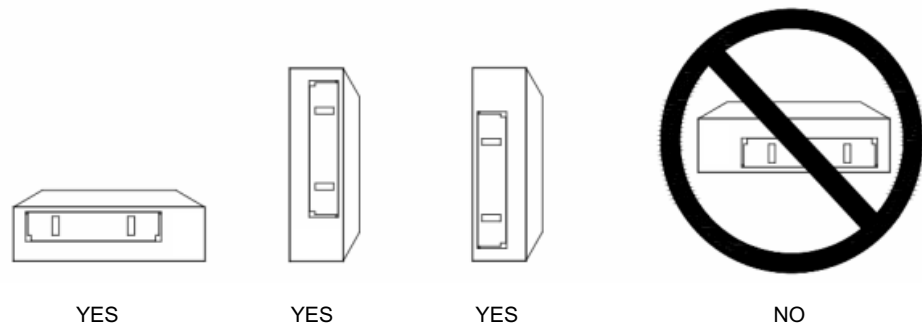

Mount the internal drive in a 5.25-inch, half-height drive bay as follows:

- 1 As required:
  - a Save and close your open files and terminate all running applications.
  - b Shut down the workstation or server system.
  - c Disconnect the system AC power cord from the facility AC power receptacle.
- 2 Remove the cover from the workstation or server system.

**Note:** See your computer manufacturer's instructions for the proper procedures to remove the cover.

- 3 Select an available 5.25-inch half-height bay and, if required, remove the bay cover.
- 4 Position the drive in the bay and align either the upper or lower mounting holes—whichever is appropriate—with the holes in the chassis (see [figure 3](#)).
- 5 Secure the drive using two Phillips screws labeled **General Mounting Screws** on each side of the tape drive. If you cannot tighten the Phillips screws, use the washers provided with the **General Mounting Screws**.

---

**Caution:** Using screws other than the Phillips screws labeled as **General Mounting Screws** can damage the tape drive.  
**Do not** use screws other than the **General Mounting Screws** to secure the internal LTO-6 Half-Height Tape Drive.

---

After mounting the internal LTO-6 Half-Height Tape Drive, proceed to [Connecting the Internal Half-Height Drive Interfaces](#) in the following subsection.

Figure 3 Internal Tape Drive Mounting Hole Locations

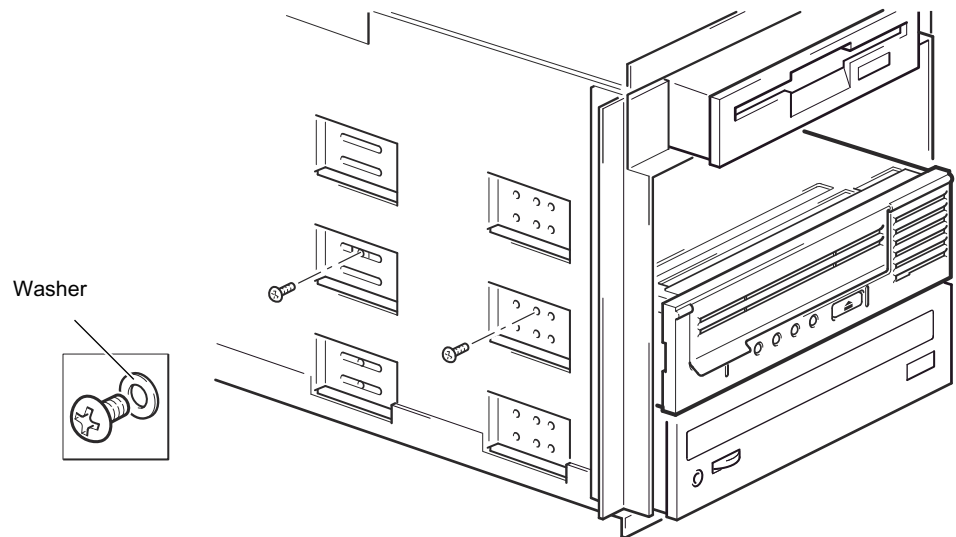
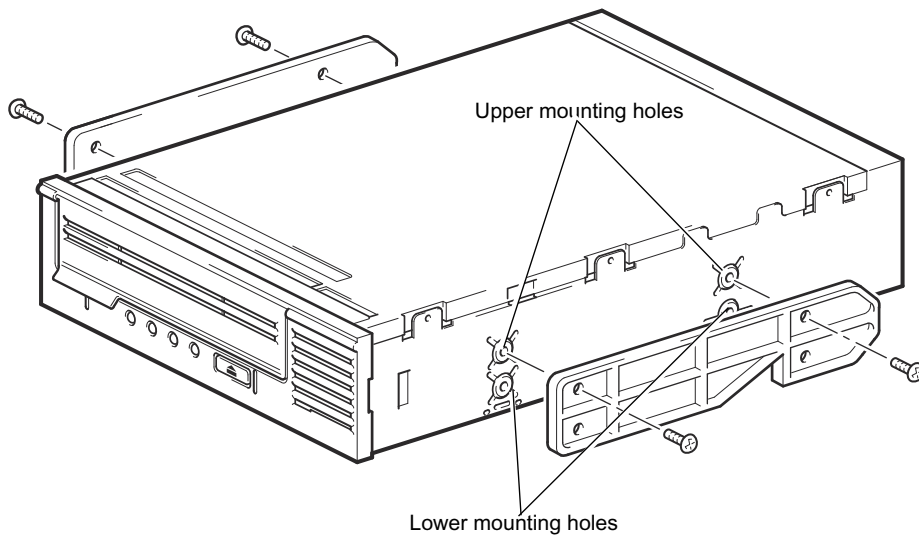

## Connecting the Internal Half-Height Drive Interfaces

As shown in [figure 4](#), the rear panel of the internal LTO-6 Half-Height Tape Drive has connectors for:

- 29-pin SFF-8482 SAS cable

Figure 4 Internal Drive Interfaces

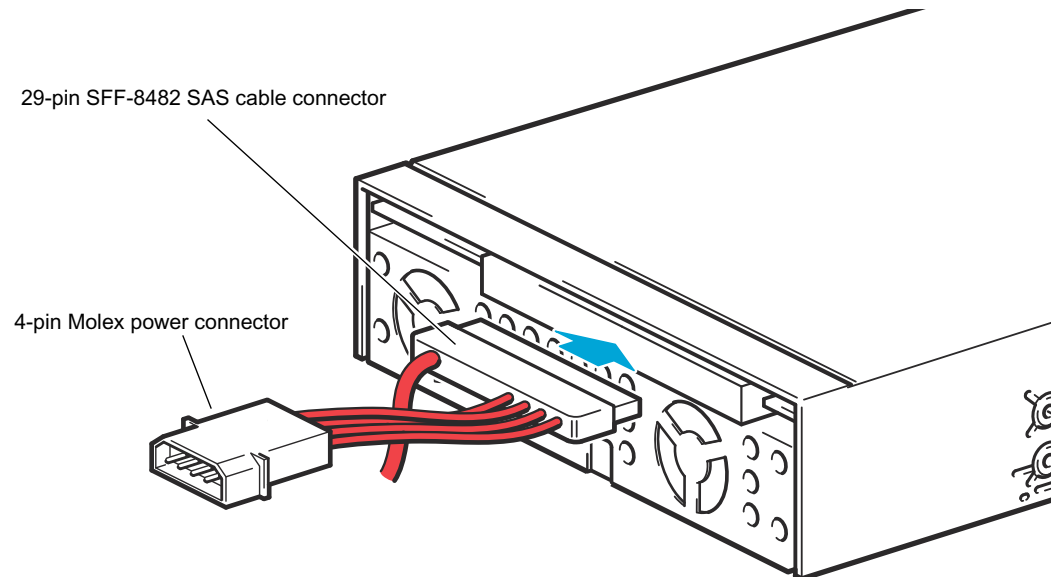

Connect the interface cables to the internal drive as follows:

- 1 Verify that the system is shut down and the AC power cord is disconnected from the facility AC power receptacle.
- 2 Connect the SAS connector on the back of the tape drive to a serial SCSI host bus adapter (HBA) installed in the server.
- 3 Ensure that a 4-pin Molex power connector is plugged into the power inputs of the SAS cable as shown in [figure 4](#).
- 4 Reinstall the system cover.
- 5 Reconnect the system AC power cord to the facility AC power receptacle.

After connecting the internal drive interfaces, proceed to [Restarting the Internal Half-Height Tape Drive System](#) in the following subsection.

## Restarting the Internal Half-Height Tape Drive System

After connecting the internal drive interface cables:

- 1 Restart the workstation or server system.
- 2 Verify that the internal LTO-6 Half-Height Tape Drive comes on and completes the Power On Self Test (POST) functions.

As required, proceed to [Installing the LTO Driver Software](#) on page 9.

## Installing the Tabletop LTO-6 Tape Drive

### Installing the Tabletop LTO-6 Half-Height Tape Drive

To install the tabletop LTO-6 Half-Height Tape Drive, complete the following procedures in the order presented:

- 1 [Connecting the Tabletop Drive Interface and AC Power Cables](#)
- 2 [Restarting the Tabletop Half-Height Tape Drive System](#) on page 9
- 3 [Installing the LTO Driver Software](#) on page 9, if required

### Connecting the Tabletop Drive Interface and AC Power Cables

As shown in [figure 5](#), the rear panel of the tabletop LTO-6 Half-Height Tape Drive has connectors for:

- A 26-pin SFF-8088 mini-SAS style interface cable
- The AC power cable

Figure 5 Tabletop Half-Height Drive Interface and AC Power Connectors

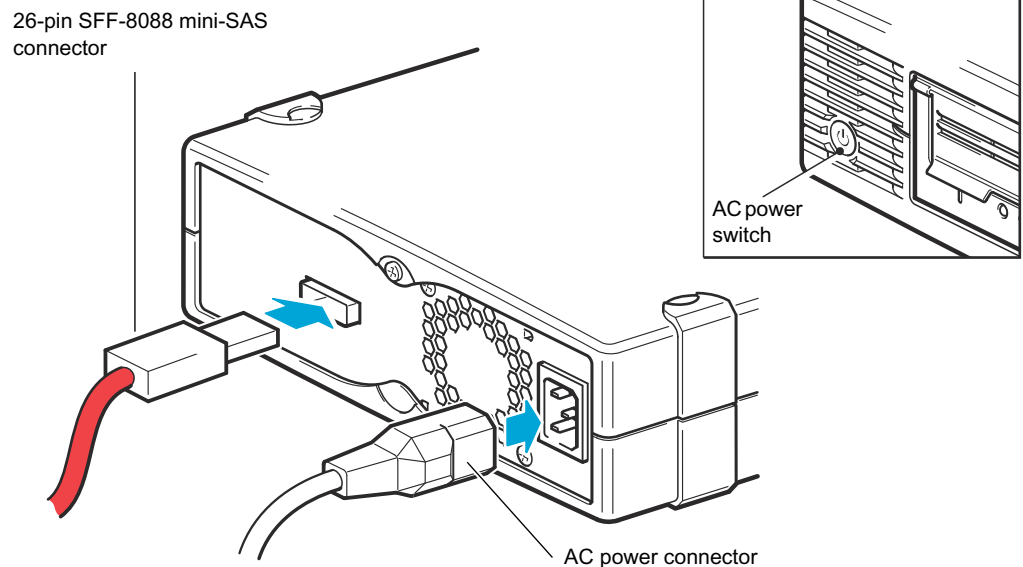

Connect the interface and AC power cables to the tabletop drive as follows:

- 1 As required:
  - a Save and close your open files and terminate all running applications.
  - b Shut down the workstation or server system.
  - c Disconnect the system AC power cord from the facility AC power receptacle.



- 2 Attach the external SAS interface cable to the 26-pin SFF-8088 mini-SAS connector on the back of the drive.
- 3 Verify that the tabletop LTO-6 Half-Height Tape Drive AC power switch is set to the off position, and connect the AC power cord to the power connector on the back of the drive.
- 4 Connect the drive AC power cord to the facility AC power receptacle.
- 5 Reconnect the workstation or server system AC power cord to the facility AC power receptacle.

After connecting the tabletop drive interface and AC power cables, proceed to [Restarting the Tabletop Half-Height Tape Drive System](#) in the following subsection.

### Restarting the Tabletop Half-Height Tape Drive System

After connecting the tabletop drive interface and AC power cables:

- 1 Set the tabletop drive AC power switch to the on position.
- 2 Restart the workstation or server system.
- 3 Verify that the tabletop LTO-6 Half-Height Tape Drive comes on and completes the Power On Self Test (POST) functions.

As required, proceed to [Installing the LTO Driver Software](#).

---

## Installing the LTO Driver Software

If you intend to use the LTO-6 Tape Drive with the Microsoft® native backup applet on a Windows 2000, Windows Server® 2003, Windows 2008 Server®, Windows XP®, or Windows Vista operating system, install the appropriate version of the LTO driver software available at [www.quantum.com](http://www.quantum.com).

---

**Note:** The LTO driver software is not necessary with commercial backup application software.

---

## Safety Compliances

The LTO-6 Half-Height Tape Drives are safety compliant with the relevant editions and amendments of the regulatory organizations and codes in the countries indicated:

<b>Country</b>	<b>Regulatory Organization</b>
Canada	Canadian Standards Association (CSA)
EU member nations	Comité Européen de Normalisation Electrotechnique – the European Committee for Electrotechnical Standardization (CENELEC)
IECEE member nations*	IECEE International Electrotechnical Commission on Electrical Equipment (IECEE) for Mutual Recognition of Test Certificates for Electrical Equipment “CB Scheme”
Taiwan	BSMI
United States	Underwriters Laboratories (UL)

\* IECEE member nations include: Argentina, Austria, Australia, Belgium, Brazil, Canada, China (PR), Czech Republic, Denmark, Finland, France, Germany, Hungary, India, Ireland, Israel, Italy, Japan, (South) Korea, Montenegro, Netherlands, Norway, Poland, Russian Federation, Serbia, Singapore, Slovakia, Slovenia, South Africa, Spain, Switzerland, Turkey, United Kingdom, and USA.

## Electromagnetic Compatibility (EMC) Compliances

The LTO-6 Half-Height Tape Drives are EMC compliant with the relevant editions and amendments of the regulatory organizations and codes in the countries indicated:

Country	Regulatory Organization
Australia	Australian Communications and Media Authority (ACMA)
Canada	Industry Canada Digital Apparatus - Interference-Causing Equipment Standard (ICES-003)
EU member nations	CE
Japan	Voluntary Control Council for Interface (VCCI)
New Zealand	Australian Communications and Media Authority (ACMA)
South Korea	MIC
Taiwan	Bureau of Commodity Inspection and Quarantine (BSMI)
United States	Federal Communications Commission (FCC)

**Note:** Use these drives only in equipment where the combination has been determined to be suitable by an appropriate certification organization (for example, Underwriters Laboratories Inc. or the Canadian Standards Association in North America).

You should also consider the following safety points:

- Install the drive in an enclosure that limits the user's access to live parts, gives adequate system stability, and provides the necessary grounding for the drive.
- Provide the correct voltages (+5 VDC and +12 VDC) based on the regulation applied—Extra Low Voltage (SELV) for UL and CSA, and Safety Extra Low Voltage for BSI and VDE (if applicable).



For assistance, contact the Quantum Customer Support Center:

USA: 800-284-5101 (toll free) or 949-725-2100

EMEA: 00800-4-782-6886 (toll free) or +49 6131 3241 1164

APAC: +800 7826 8887 (toll free) or +603 7953 3010

Worldwide: <http://www.quantum.com/ServiceandSupport>

# Quantum®

**Backup. Recovery. Archive. It's What We Do.**

©2012 Quantum Corporation. All rights reserved. Quantum, the Quantum logo, and all other logos are registered trademarks of Quantum Corporation or of their respective owners. Protected by Pending and Issued U.S. and Foreign Patents, including U.S. Patent No. 5,990,810.

## About Quantum

Quantum Corp. (NYSE:QTM) is the leading global storage company specializing in backup, recovery and archive. Combining focused expertise, customer-driven innovation, and platform independence, Quantum provides a comprehensive range of disk, tape, media and software solutions supported by a world-class sales and service organization. This includes the DXi™-Series, the first disk backup solutions to extend the power of data deduplication and replication across the distributed enterprise. As a long-standing and trusted partner, the company works closely with a broad network of resellers, OEMs and other suppliers to meet customers' evolving data protection needs.