



1U Rackmount Enclosure Quick Start Guide

Introduction

The 1U Rackmount enclosure is provided with either one or two of the following supported tape drives already installed:

- DAT-72, models CD72 and CD144
- DLT-V4, models CV1303 and CV1304
- DLT VS160, models BHFCA-EO, BHFCA-EY, BHGCA-EO and BHGCA-EY
- LTO-2 Half-Height, models CL1003 and CL1004
- LTO-3 Half-Height, models TC-L33CX-EO, TC-L33CX-EY, TC-L33CN-EY and TC-L33CN-EO
- LTO-4 Half-Height, models TC-L43CN-EY and TC-L43CN-EO

You can upgrade a single-drive enclosure to the two-drive configuration by installing a second tape drive using any supported model of the same type interface – you cannot mix parallel SCSI drives and serial-attached SCSI (SAS) drives in the same enclosure.

This guide references the instructions for installing the 1U Rackmount enclosure in an equipment rack, and provides the procedures for:

- Connecting the drive interface and power cables
- Installing a second tape drive into the 1U Rackmount enclosure

Power Requirements

Power requirements for the 1U Rackmount enclosure are as follows:

- 100 to 240 Volts AC/2 to 4 Amps
- 47 to 63 Hz

Contents

This document is provided in the following languages:

- English
- French
- German
- Japanese
- Korean
- Simplified Chinese
- Spanish

Each language includes the following sections:

- [Introduction](#)
- [Installing the 1U Rackmount Enclosure in an Equipment Rack](#)
- [Connecting the Drive Interface and Power Cables](#)
- [Installing a Second Tape Drive](#)
- [Class A Device Declarations](#)

Installing the 1U Rackmount Enclosure in an Equipment Rack

Each 1U Rackmount enclosure is provided with a mounting kit and accessories. Refer to the installation instructions included with the mounting kit to install the 1U Rackmount enclosure into your equipment rack.

Warning: For maximum stability, make sure that the equipment rack is securely bolted to the floor per the rack manufacturer's recommendations.

After installing components in the equipment rack, do not pull out more than one component on its slide rails at a time. If the equipment rack is not securely bolted to the floor, the weight of more than one extended component could cause the equipment rack to become unstable, tip over, and cause damage, serious bodily injury, or death.

Connecting the Drive Interface and Power Cables

- 1 Shut down and turn off the host server system.
- 2 Turn off all attached accessory devices, such as printers and other SCSI devices.
- 3 On the back panel of the 1U Rackmount enclosure, depending on the interface configuration of the installed tape drive:
 - a For a parallel SCSI drive:
 - Connect one end of the supplied external parallel SCSI cable to either of the two parallel SCSI connectors on the same side of the enclosure as the installed tape drive (see [figure 1](#)).
 - Connect the supplied SCSI terminator to the other parallel SCSI connector on the same side of the enclosure as the installed tape drive.
 - Connect the other end of the supplied external parallel SCSI cable to the parallel SCSI connector on the host server.
 - As required, use the parallel SCSI ID selector switch to set the SCSI ID of the installed tape drive (see [figure 2](#)).

Note: Any time you change the parallel SCSI ID, you must turn the tape drive power off and then back on by pressing the power button on the front panel of the 1U Rackmount enclosure.

Figure 1 Parallel SCSI Interface Connectors

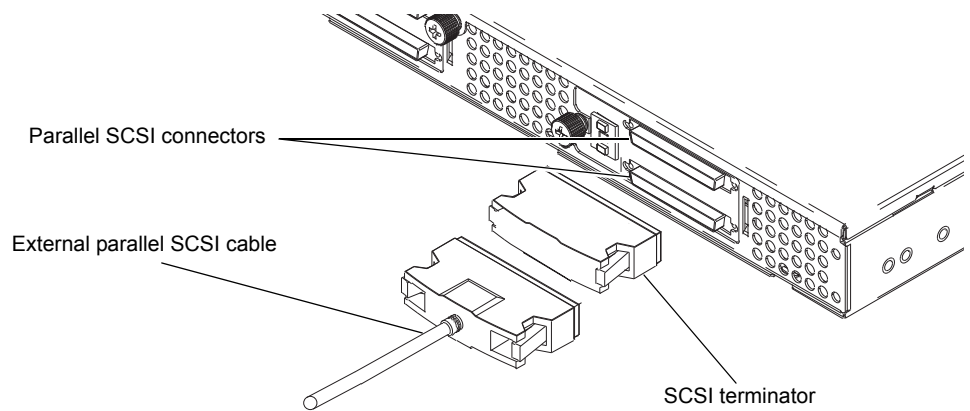
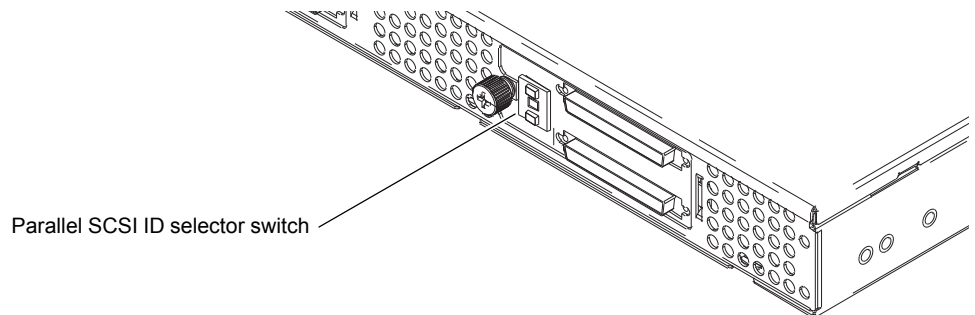

Figure 2 Parallel SCSI ID Selector Switch



b For a serial-attached SCSI (SAS) drive:

- Connect one end of the supplied external SAS interface cable to the external SAS interface connector on the same side of the enclosure as the installed tape drive (see [figure 3](#)).
- Connect the other end of the external SAS interface cable to the SAS connector on the host server.

Figure 3 Serial-attached SCSI (SAS) Interface Connector

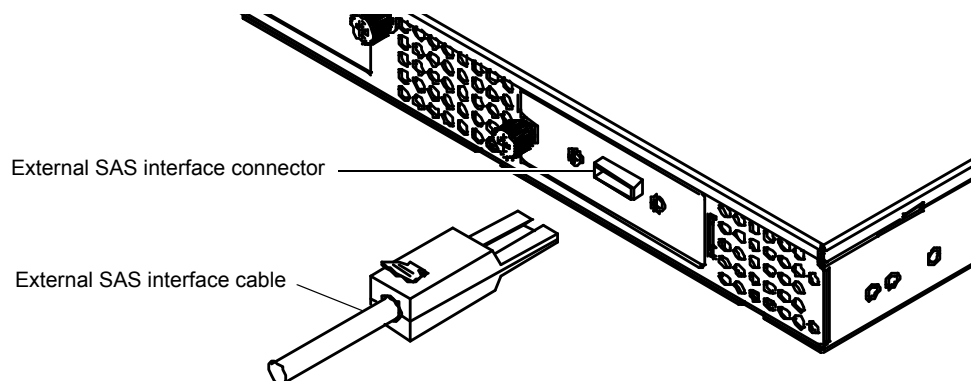

- 4** Connect the supplied AC power cable to the AC power connector on the back panel of the 1U Rackmount enclosure (see [figure 4](#)).

Figure 4 AC Power Connector

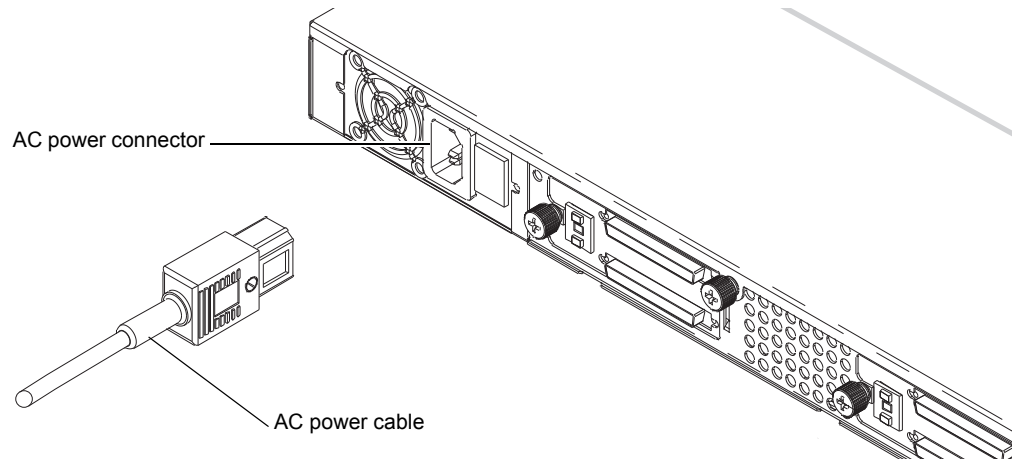

- 5 Connect the other end of the AC power cable to the rack/facility AC power receptacle.
- 6 Press the master AC power pushbutton switch on the back panel of the 1U Rackmount enclosure to apply power to the enclosure.
- 7 Press the drive power pushbutton switch on the front panel of the 1U Rackmount enclosure, illuminating the green power LED.
- 8 Turn on all attached accessory devices, such as printers and other SCSI devices that you turned off at step 2 of this procedure.
- 9 Turn on and restart the host server.

Installing a Second Tape Drive

Follow these instructions to install a second tape drive or to reinstall a tape drive after it has been removed.

Caution: Before installing a second tape drive, you must turn off the 1U Rackmount enclosure and disconnect it from its AC power source.

Preinstallation Requirements

Before installing a second tape drive in the 1U Rackmount enclosure, make sure you have the following required tools and parts:

Tools	#1 and #2 Phillips screwdrivers
Parts	<ul style="list-style-type: none"> • A supported model tape drive • Depending on the interface of the tape drive, either an external: <ul style="list-style-type: none"> • Parallel SCSI cable and terminator • Serial-attached SCSI (SAS) interface cable

Procedure

Install a second tape drive inside the 1U Rackmount enclosure as follows:

- 1 Press the drive power pushbutton switch on the front panel of the 1U Rackmount enclosure to turn off the drive power.
- 2 Press the master AC power pushbutton switch on the back panel of the 1U Rackmount enclosure to turn off the enclosure power.
- 3 Disconnect the AC power cable from the AC power connector on the back panel of the 1U Rackmount enclosure.
- 4 Remove the 1U Rackmount enclosure from the equipment rack and place it on a clean, stable, flat surface.
- 5 Loosen the captive thumbscrew securing the top cover to the back panel (see [figure 5](#)).

Figure 5 Top Cover
Thumbscrew

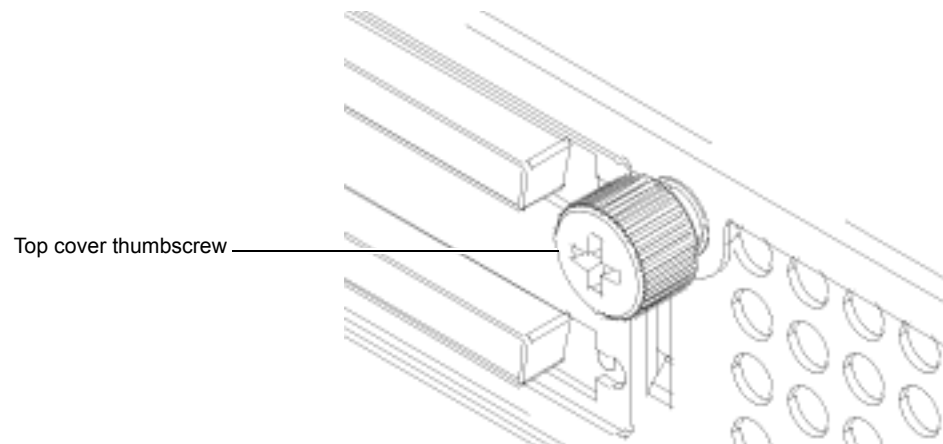

- 6 Slide the top cover toward the back of the enclosure about 1/2 inch to disengage it from the front clips and lift the top cover off the enclosure (see [figure 6](#)).

Figure 6 Removing the Top
Cover

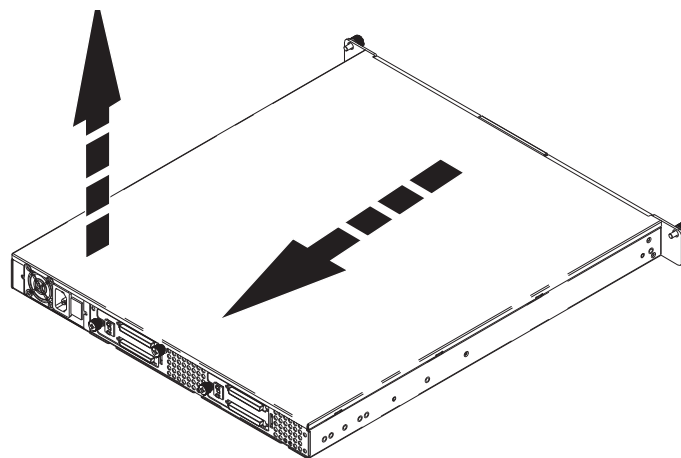

- 7 Inside the chassis, use a #2 Phillips screwdriver to remove the two screws securing the front filler panel to the enclosure chassis and remove the filler panel (see [figure 7](#)).
- 8 Remove the foam insert from the center bulkhead (see [figure 8](#)).

Figure 7 Removing the Front Filler Panel

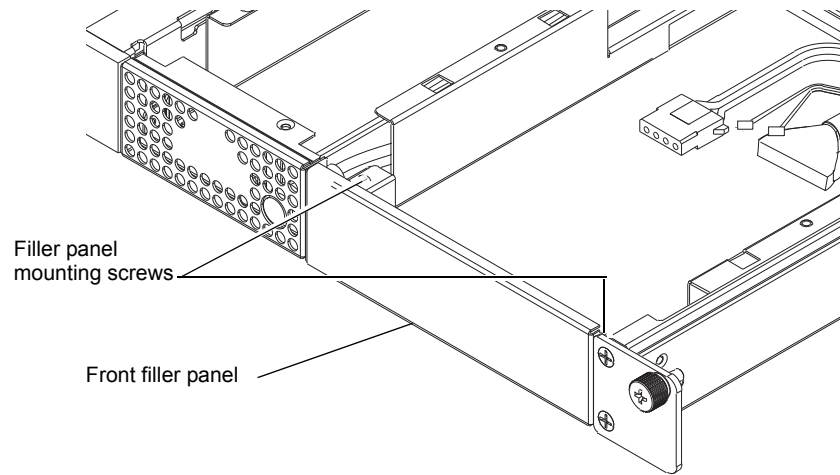
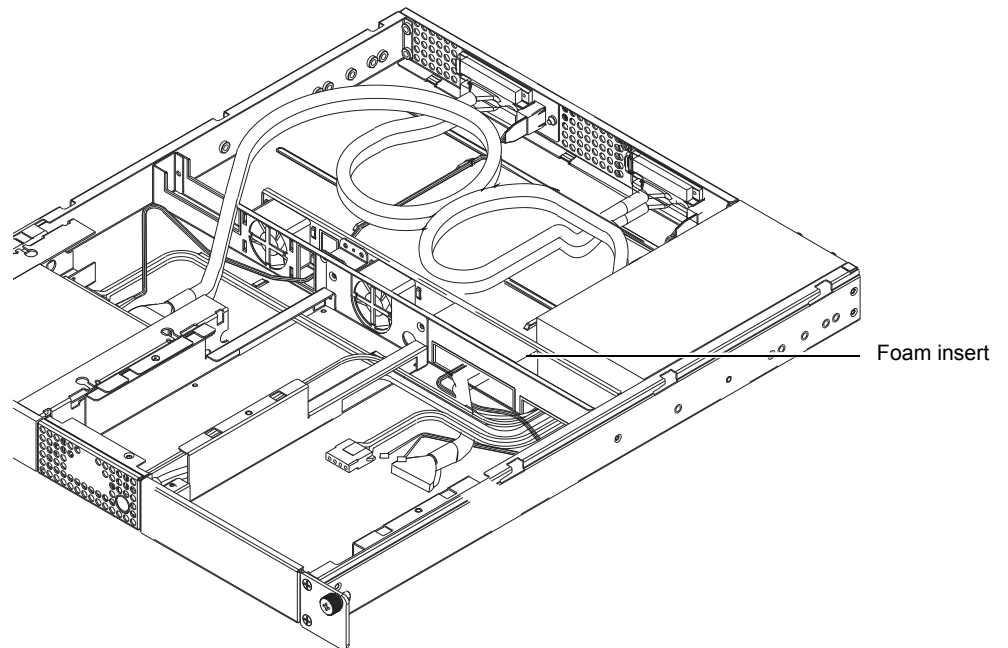
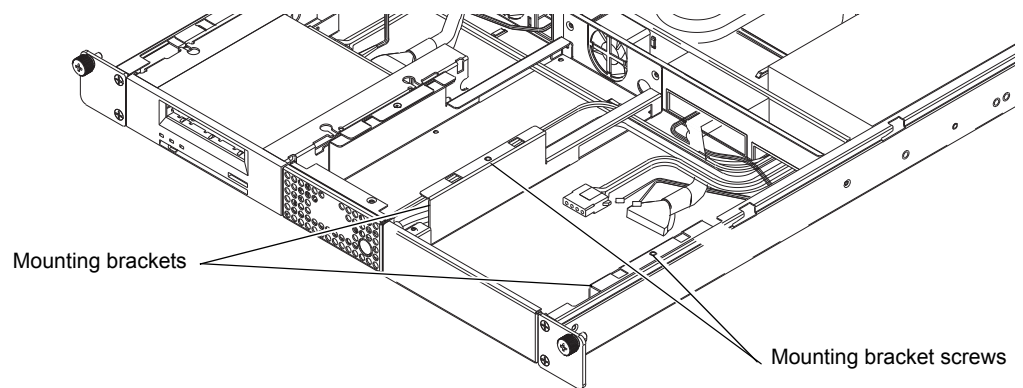

Figure 8 Removing the Foam Insert



- 9 Using a #1 Phillips screwdriver, remove the mounting screw that secures each mounting bracket to the enclosure chassis and remove the two mounting brackets (see [figure 9](#)).

Figure 9 Removing the Mounting Brackets



10 Depending on the model and interface configuration of the tape drive you are installing, connect the internal interface cables to the tape drive back panel connectors as follows:

IF you are installing a . . . tape drive	THEN see figure . . .	AND connect the . . .
DAT 72	10	<ul style="list-style-type: none"> Internal SCSI cable to the SCSI connector. SCSI ID cable labeled DDS to the SCSI ID connector, oriented such that the cable pin with the purple wire is connected to the upper-right SCSI ID pin as shown.
DLT-V4	11	
DLT VS160		
LTO-2 Half-Height	12	<ul style="list-style-type: none"> Internal SCSI cable to the SCSI connector. SCSI ID cable labeled LTO to the 12 right-most pins of the SCSI ID connector, oriented such that the cable pin with the purple wire is in the upper-left position as shown. (The eight left-most pins are not used.)
LTO-3 Half-Height, parallel SCSI	13	<ul style="list-style-type: none"> Internal SCSI cable to the SCSI connector. SCSI ID cable labeled LTO to the SCSI ID connector, oriented such that the cable pin with the purple wire is in the upper-left position as shown.
LTO-3 Half-Height, serial-attached SCSI	14	<ul style="list-style-type: none"> Internal serial-attached SCSI (SAS) cable to the SAS connector.
LTO-4 Half-Height	15	

Figure 10 DAT 72 SCSI Connections

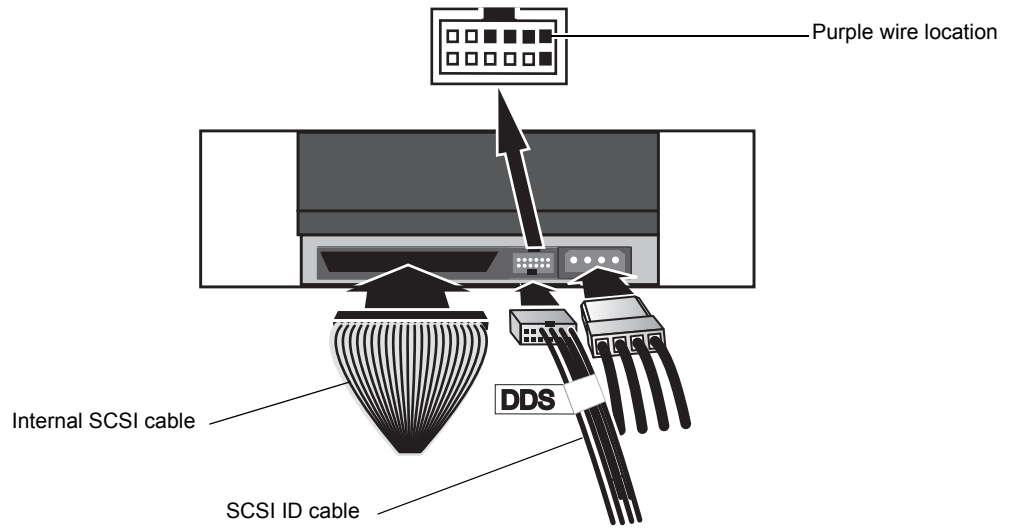

Figure 11 DLT-V4 and DLT VS160 SCSI Connections

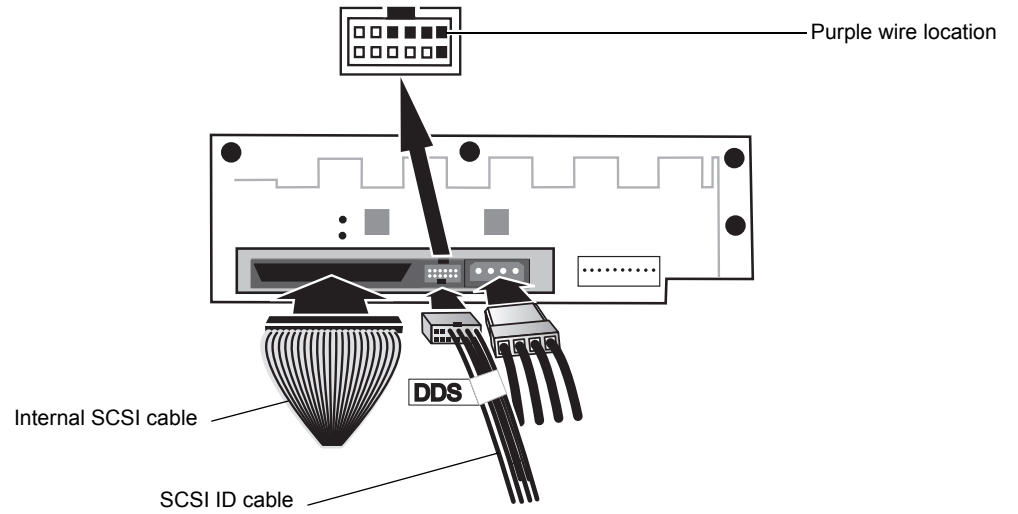

Figure 12 LTO-2 Half-Height SCSI Connections

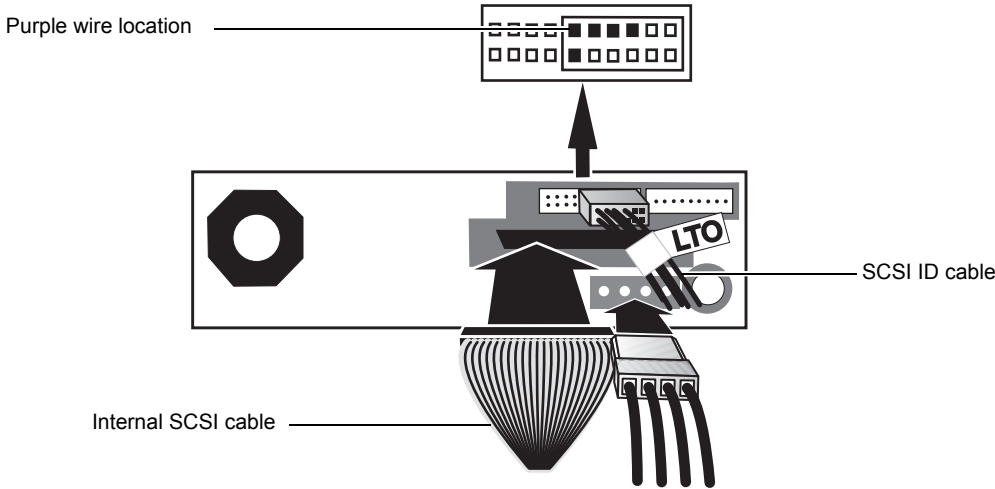

Figure 13 LTO-3 Half-Height Parallel SCSI Connections

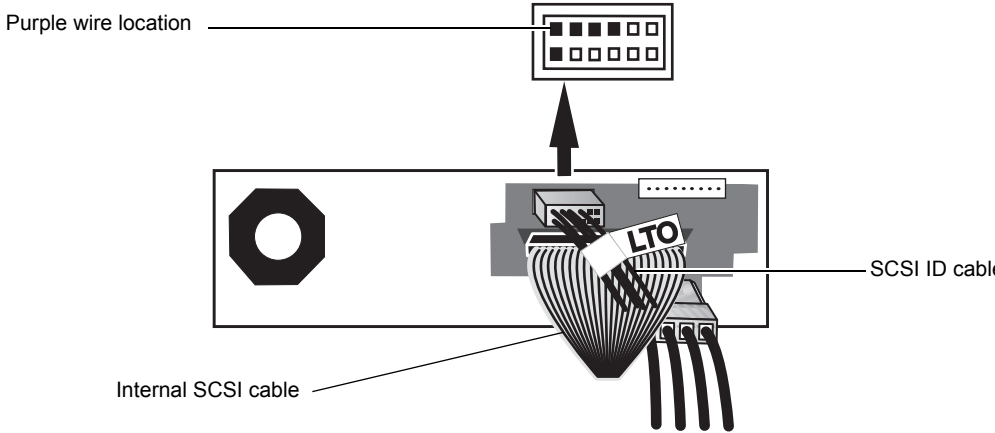

Figure 14 LTO-3 Half-Height Serial-attached SCSI (SAS) Connections

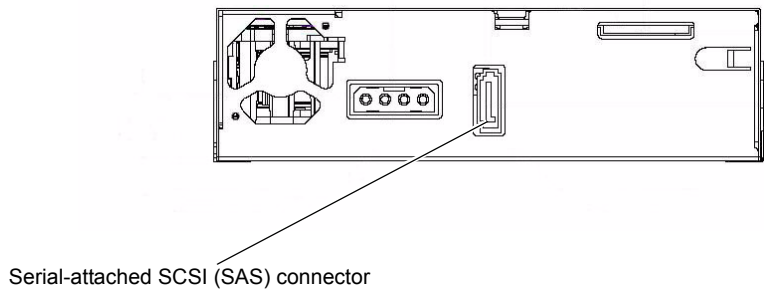
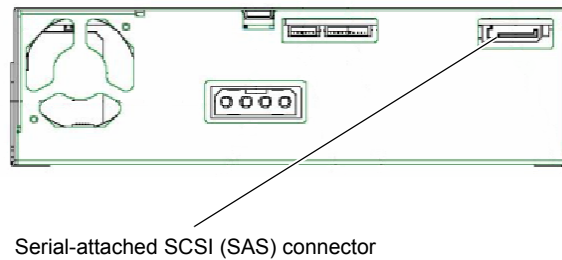
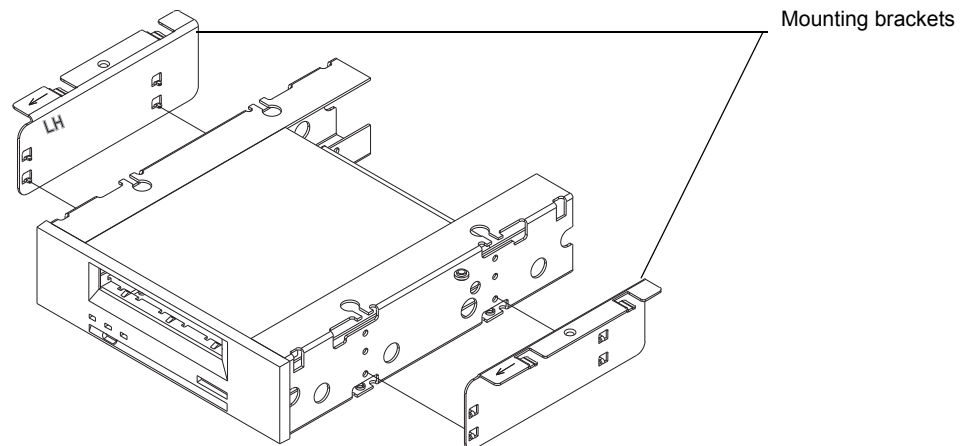

Figure 15 LTO-4 Half-Height Serial-attached SCSI (SAS) Connections



- 11 Connect the 1U Rackmount enclosure internal drive DC power cable to the DC power connector on the back of the tape drive.
- 12 Insert the two posts on each mounting bracket into the two mounting holes on either side of the second tape drive (see [figure 16](#)). If the tape drive has four mounting holes, insert the posts into the lower set of mounting holes.
- 13 While holding the mounting brackets against the tape drive, position the tabs of the mounting brackets over the retaining holes in the tape drive bay of the 1U Rackmount enclosure (see [figure 17](#)).

Figure 16 Attaching the Mounting Brackets



Caution: Make sure that the locating tabs on the mounting brackets are fully seated within the mounting holes of the tape drive, and that the mounting brackets sit completely flush with the sides of the tape drive. Failure to ensure this required alignment might cause faulty tape drive operation after the 1U Rackmount enclosure is reinstalled into the equipment rack.

Figure 17 Positioning the Tape Drive

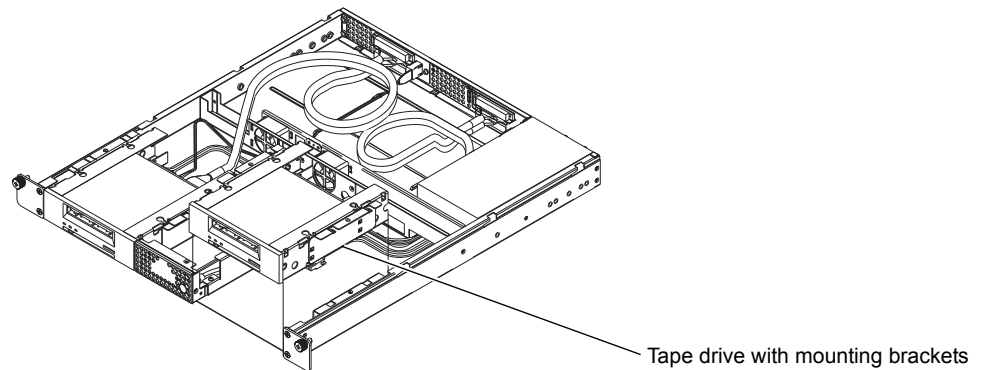

- 14 Lower the tape drive with mounting brackets into the tape drive bay of the 1U Rackmount enclosure and slide the assembly toward the back of the enclosure until:
 - The front of the tape drive is flush with the front panel
 - The tabs on the mounting brackets slide into the retaining holes on each side of the tape drive bay (see [figure 18](#))
- 15 Using a #1 Phillips screwdriver, reinstall the mounting screw that secures each mounting bracket to the enclosure chassis (see [figure 19](#)).
- 16 Replace the 1U Rackmount enclosure top cover and tighten the top cover thumbscrew (see [figure 5](#) on page 5).
- 17 Reinstall the 1U Rackmount enclosure into the equipment rack.

Figure 18 Sliding the Tape Drive Into the Drive Bay

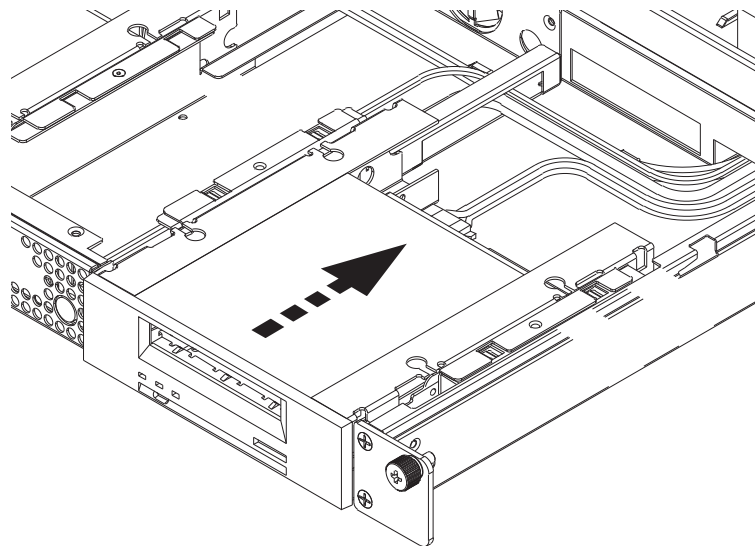
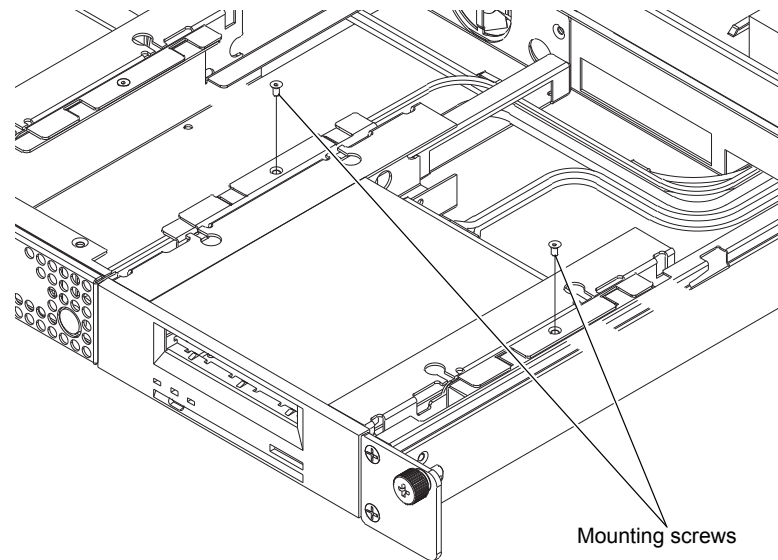

Figure 19 Reinstalling the Mounting Bracket Screws



- 18** On the back panel of the 1U Rackmount enclosure, depending on the interface configuration of the newly installed tape drive:
 - a** For a parallel SCSI drive:
 - Connect one end of an external parallel SCSI cable to either of the two SCSI connectors on the same side of the enclosure as the newly installed tape drive (see [figure 1](#) on page 3).
 - Connect a SCSI terminator to the other SCSI connector.
 - Connect the other end of the external parallel SCSI cable to the SCSI on the host server.
 - As required, use the parallel SCSI ID selector switch to set the SCSI ID of the newly installed tape drive (see [figure 2](#) on page 3).
- Note:** Any time you change the parallel SCSI ID, you must turn the tape drive power off and then back on by pressing the power button on the front panel of the 1u Rackmount enclosure.
- b** For a serial-attached SCSI (SAS) drive:
 - Connect one end of an external SAS interface cable to the external SAS interface connector on the same side of the 1U Rackmount enclosure as the newly installed tape drive (see [figure 3](#) on page 3).
 - Connect the other end of the external SAS interface cable to the SAS connector on the host server.
- 19** Reconnect the AC power cable to the power connector on the back panel of the 1U Rackmount enclosure.
 - 20** Press the master AC power pushbutton switch on the pack panel of the 1U Rackmount enclosure to apply power to the enclosure.
 - 21** Press the drive power by pushbutton switch on the front panel of the 1U Rackmount enclosure, illuminating the green power LED.

Class A Device Declarations

Warning: This equipment has been tested and found to comply with the limits for a Class A digital device pursuant to Part 15 of the FCC Rules. These limits are designed to provide reasonable protection against harmful interference when the equipment is operated in a commercial environment. This equipment generates, uses, and can radiate radio frequency energy and, if not installed and used in accordance with the instruction's manual, might cause interference to radio communications. Operation of this equipment in a residential area is likely to cause interference, in which case users are required to correct the interference at their expense.

The user is cautioned that changes and modifications made to the equipment without approval of the manufacturer could void the user's authority to operate this equipment.



81-81540-04 A01



For assistance contact Quantum Technical Assistance center:
North America **+1-800-284-5101**
UK, France, and Germany **00800 4 QUANTUM**
EMEA **+44 1256 848 766**

For worldwide support: www.quantum.com/contactsupport

Quantum[®]
Backup. Recovery. Archive. It's What We Do.

©2007 Quantum Corporation. All rights reserved. Quantum, the Quantum logo, and all other logos are registered trademarks of Quantum Corporation or their respective owners.

Quantum Corp. (NYSE: QTM) is the leading global storage company specializing in backup, recovery and archive. Combining focused expertise, customer-driven innovation, and platform independence, Quantum provides a comprehensive range of disk, tape, media, and software solutions supported by a world-class sales and service organization. As a long-standing and trusted partner, the company works closely with a broad network of resellers, OEMs, and other suppliers to meet customer's evolving data protection needs.